

SavantIC Semiconductor

Product Specification

Silicon PNP Power Transistors

BDW84/84A/84B/84C/84D

DESCRIPTION

- With TO-3PN package
- Complement to type BDW83/83A/83B/83C/83D
- DARLINGTON
- High DC current gain

APPLICATIONS

- For use in power linear and switching applications.

PINNING

PIN	DESCRIPTION
1	Base
2	Collector;connected to mounting base
3	Emitter

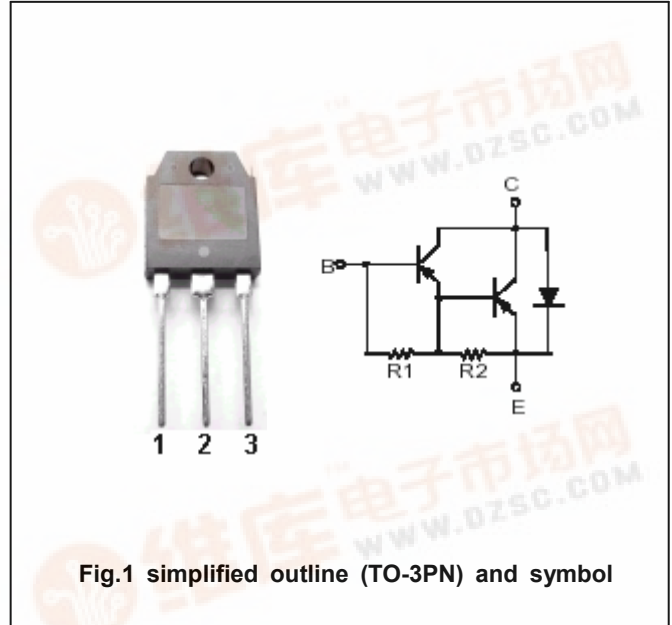

Fig.1 simplified outline (TO-3PN) and symbol

Absolute maximum ratings(Tc=25°C)

SYMBOL	PARAMETER	CONDITIONS	VALUE	UNIT
V _{CBO}	Collector-base voltage	BDW84	-45	V
		BDW84A	-60	
		BDW84B	-80	
		BDW84C	-100	
		BDW84D	-120	
V _{CEO}	Collector-emitter voltage	BDW84	-45	V
		BDW84A	-60	
		BDW84B	-80	
		BDW84C	-100	
		BDW84D	-120	
V _{EBO}	Emitter-base voltage	Open collector	-5	V
I _C	Collector current		-15	A
I _B	Base current		-0.5	A
P _C	Collector power dissipation	T _c =25°C	150	W
		T _a =25°C	3.5	
T _j	Junction temperature		150	°C
T _{stg}	Storage temperature		-65~150	°C

Silicon PNP Power Transistors

BDW84/84A/84B/84C/84D

CHARACTERISTICS

T_j=25°C unless otherwise specified

SYMBOL	PARAMETER	CONDITIONS	MIN	TYP.	MAX	UNIT	
V _{(BR)CEO}	Collector-emitter breakdown voltage	BDW84	I _C =-30mA, I _B =0	-45			V
		BDW84A		-60			
		BDW84B		-80			
		BDW84C		-100			
		BDW84D		-120			
V _{CEsat-1}	Collector-emitter saturation voltage	I _C =-6A, I _B =-12mA			-2.5	V	
V _{CEsat-2}	Collector-emitter saturation voltage	I _C =-15A, I _B =-150mA			-4.0	V	
V _{BE}	Base-emitter on voltage	I _C =-6A; V _{CE} =-3V			-2.5	V	
I _{CBO}	Collector cut-off current	BDW84	V _{CB} =-45V, I _E =0 T _C =150°C	-0.5		-5.0	mA
		BDW84A		-0.5		-5.0	
		BDW84B		-0.5		-5.0	
		BDW84C		-0.5		-5.0	
		BDW84D		-0.5		-5.0	
I _{CEO}	Collector cut-off current	BDW84	V _{CE} =-30V, I _B =0			-1	mA
		BDW84A		V _{CE} =-30V, I _B =0			
		BDW84B		V _{CE} =-40V, I _B =0			
		BDW84C		V _{CE} =-50V, I _B =0			
		BDW84D		V _{CE} =-60V, I _B =0			
I _{EBO}	Emitter cut-off current	V _{EB} =-5V; I _C =0			-2	mA	
h _{FE-1}	DC current gain	I _C =-6A; V _{CE} =-3V	750		20000		
h _{FE-2}	DC current gain	I _C =-15A; V _{CE} =-3V	100				
V _{EC}	Diode forward voltage	I _E =-15A			-3.5	V	
t _{on}	Turn-on time	I _C = -10 A, I _{B1} = -I _{B2} = -40 mA R _L = 3Ω; V _{BE(off)} = 4.2V Duty Cycle ≤ 2%		0.9		Ms	
t _{off}	Turn-off time			7.0		Ms	

THERMAL CHARACTERISTICS

SYMBOL	PARAMETER	MAX	UNIT
R _{th j-c}	Thermal resistance junction to case	0.83	°C/W

Silicon PNP Power Transistors

BDW84/84A/84B/84C/84D

PACKAGE OUTLINE

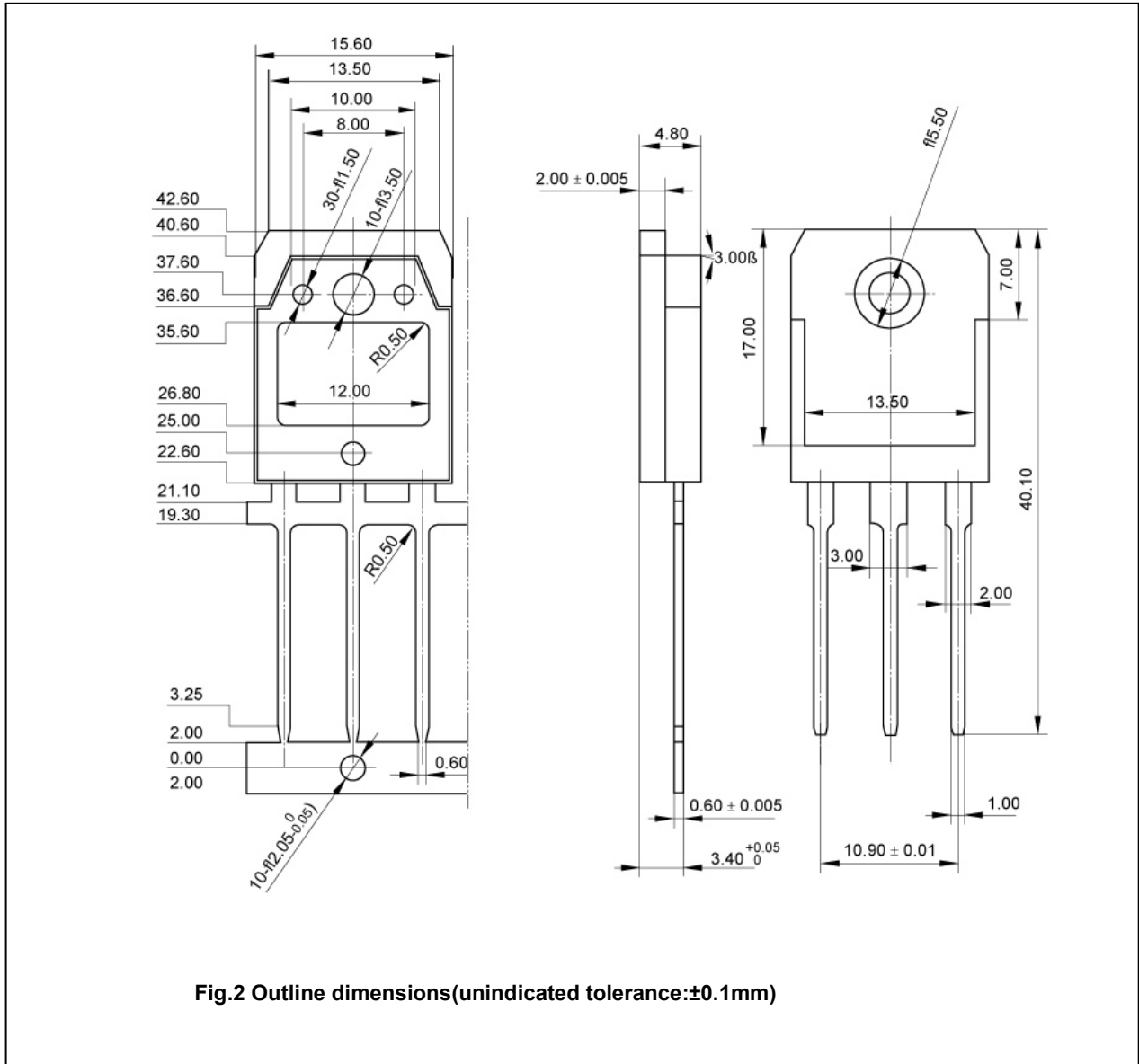

Fig.2 Outline dimensions(unindicated tolerance:±0.1mm)