

SavantIC Semiconductor

Product Specification

Silicon PNP Power Transistors

KSA614

DESCRIPTION

- With TO-220 package
- Collector-Base Voltage: $V_{CBO}=-80V(\text{Min})$
- Collector dissipation: $P_C=25W@T_C=25^\circ\text{C}$

APPLICATIONS

- Low frequency power amplifier
- Power regulator

PINNING

PIN	DESCRIPTION
1	Emitter
2	Collector;connected to mounting base
3	Base

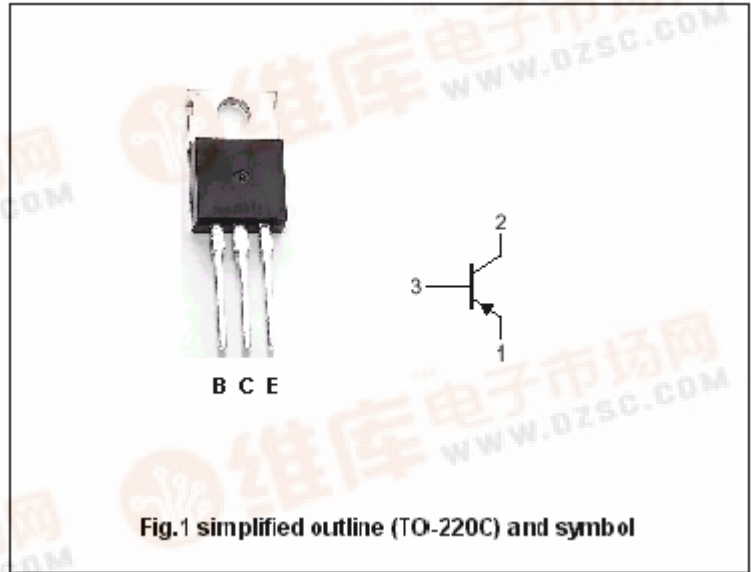

Absolute maximum ratings ($T_a=25^\circ\text{C}$)

SYMBOL	PARAMETER	CONDITIONS	VALUE	UNIT
V_{CBO}	Collector-base voltage	Open emitter	-80	V
V_{CEO}	Collector-emitter voltage	Open base	-55	V
V_{EBO}	Emitter-base voltage	Open collector	-5	V
I_C	Collector current (DC)		-3	A
P_C	Collector power dissipation	$T_C=25^\circ\text{C}$	25	W
T_j	Junction temperature		150	$^\circ\text{C}$
T_{stg}	Storage temperature		-55~150	$^\circ\text{C}$

Silicon PNP Power Transistors

KSA614

CHARACTERISTICS

T_j=25°C unless otherwise specified

SYMBOL	PARAMETER	CONDITIONS	MIN	TYP.	MAX	UNIT
V _{(BR)CEO}	Collector-emitter breakdown voltage	I _C =-10mA ; I _B =0	-80			V
V _{(BR)CBO}	Collector-base breakdown voltage	I _C =-0.5mA ; I _E =0	-55			V
V _{(BR)EBO}	Emitter-base breakdown voltage	I _E =-0.5mA ; I _C =0	-5			V
V _{CEsat}	Collector-emitter saturation voltage	I _C =-1A ; I _B =-0.1A			-0.5	V
I _{CBO}	Collector cut-off current	V _{CB} =-50V ; I _E =0			-50	μA
I _{EBO}	Emitter cut-off current	V _{EB} =-5V ; I _C =0			-50	μA
h _{FE}	DC current gain	I _C =-0.5A ; V _{CE} =-5V	40		240	

◆ h_{FE} classifications

R	O	Y
40-80	70-140	120-240

Silicon PNP Power Transistors

KSA614

PACKAGE OUTLINE

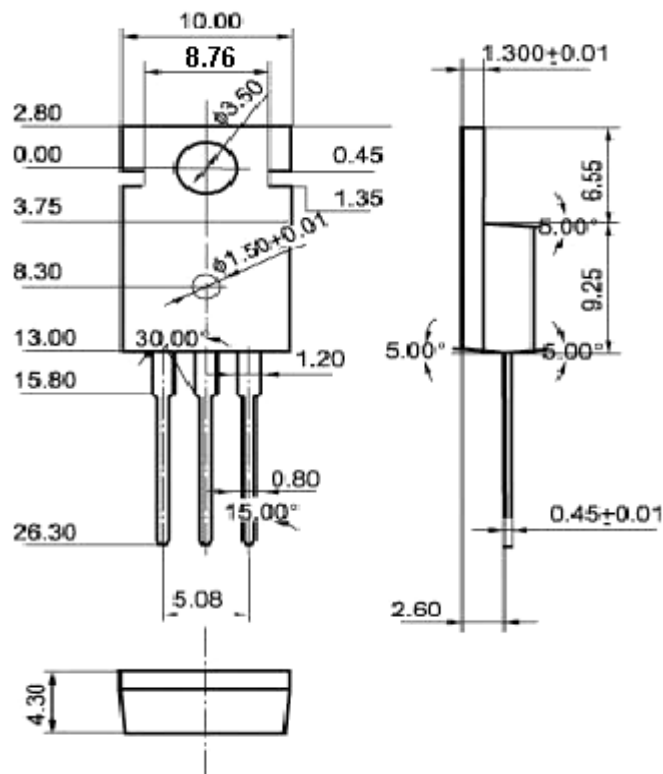

Fig.2 outline dimensions (unindicated tolerance:±0.10 mm)

Silicon PNP Power Transistors

KSA614

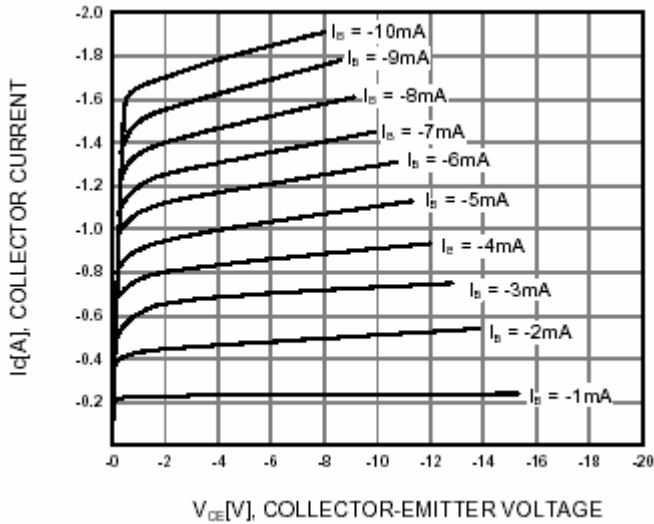

Fig.3 Static Characteristic

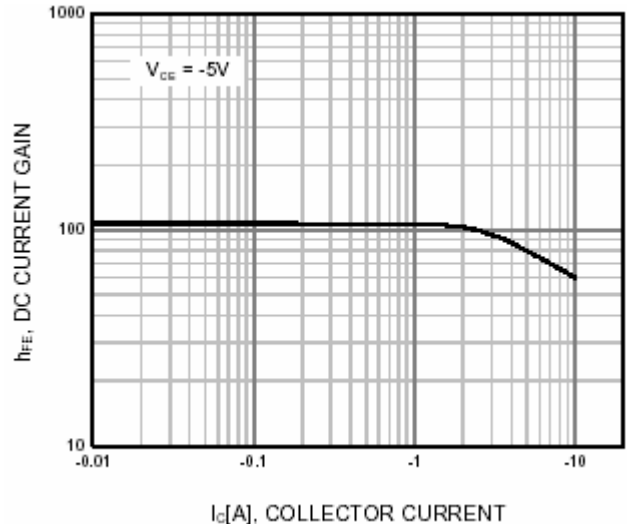

Fig.4 DC current Gain

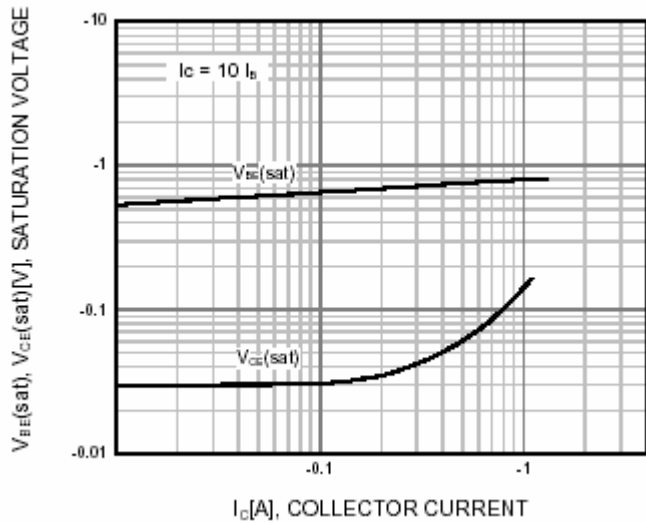

Fig.5 Base-Emitter Saturation Voltage
Collector-Emitter Saturation Voltage

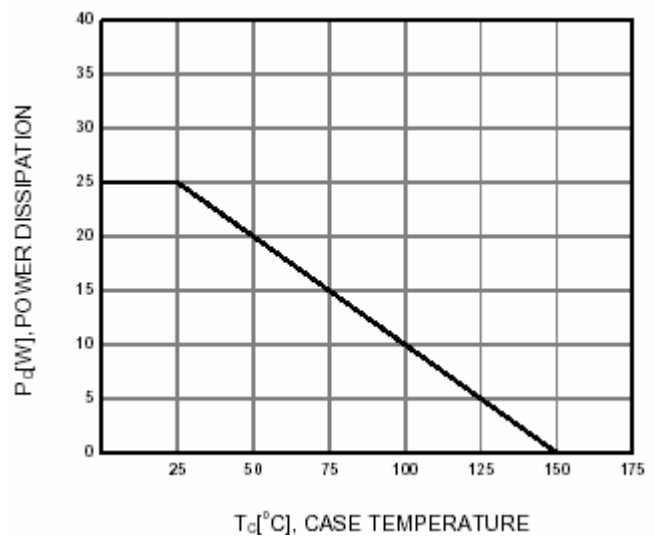

Fig.6 Power Derating

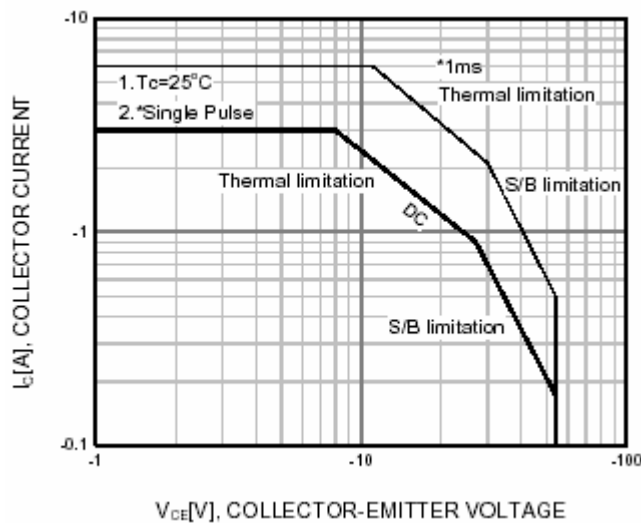

Fig.7 Safe Operating Area