

SavantIC Semiconductor

Product Specification

Silicon PNP Power Transistors

TIP42/42A/42B/42C

DESCRIPTION

- With TO-220C package
- Complement to type TIP41/41A/41B/41C

APPLICATIONS

- For medium power linear switching applications

PINNING

PIN	DESCRIPTION
1	Emitter
2	Collector;connected to mounting base
3	Base

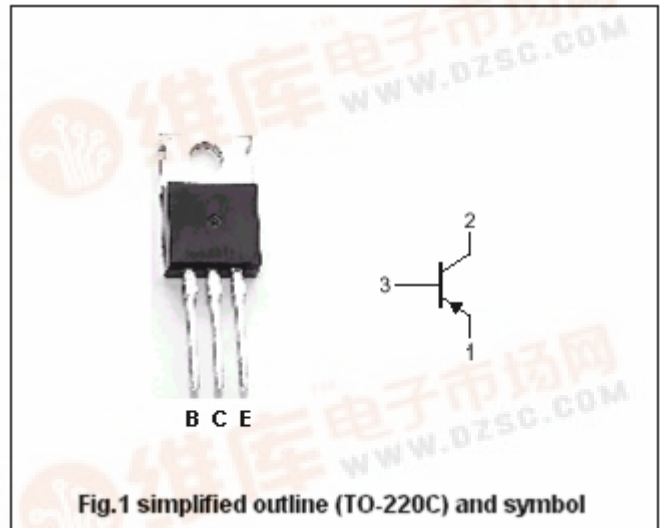

ABSOLUTE MAXIMUM RATINGS(T_C=25℃)

SYMBOL	PARAMETER	CONDITIONS	VALUE	UNIT
V _{CBO}	Collector-base voltage	TIP42	-40	V
		TIP42A	-60	
		TIP42B	-80	
		TIP42C	-100	
V _{CEO}	Collector-emitter voltage	TIP42	-40	V
		TIP42A	-60	
		TIP42B	-80	
		TIP42C	-100	
V _{EBO}	Emitter-base voltage	Open collector	-5	V
I _C	Collector current (DC)		-6	A
I _{CM}	Collector current-Pulse		-10	A
I _B	Base current		-2	A
P _C	Collector power dissipation	T _C =25℃	65	W
		T _a =25℃	2	
T _j	Junction temperature		150	℃
T _{stg}	Storage temperature		-65~150	℃

Silicon PNP Power Transistors

TIP42/42A/42B/42C

CHARACTERISTICS

T_j=25°C unless otherwise specified

SYMBOL	PARAMETER		CONDITIONS	MIN	TYP.	MAX	UNIT
V _{CEO(SUS)}	Collector-emitter sustaining voltage	TIP42	I _C =30mA; I _B =0	-40			V
		TIP42A		-60			
		TIP42B		-80			
		TIP42C		-100			
V _{CE(sat)}	Collector-emitter saturation voltage		I _C =-6A; I _B =-0.6A			-1.5	V
V _{BE}	Base-emitter on voltage		I _C =-6A; V _{CE} =-4V			-2.0	V
I _{CES}	Collector cut-off current	TIP42	V _{CE} =-40V; V _{EB} =0			-0.4	mA
		TIP42A	V _{CE} =-60V; V _{EB} =0				
		TIP42B	V _{CE} =-80V; V _{EB} =0				
		TIP42C	V _{CE} =-100V; V _{EB} =0				
I _{CEO}	Collector cut-off current	TIP41/41A	V _{CE} =-30V; I _B =0			-0.7	mA
		TIP41B/41C	V _{CE} =-60V; I _B =0				
I _{EBO}	Emitter cut-off current		V _{EB} =-5V; I _C =0			-1.0	mA
h _{FE-1}	DC current gain		I _C =-0.3A; V _{CE} =-4V	30			
h _{FE-2}	DC current gain		I _C =-3A; V _{CE} =-4V	15		75	
f _T	Transition frequency		I _C =-0.5A; V _{CE} =-10V	3			MHz

Silicon PNP Power Transistors

TIP42/42A/42B/42C

PACKAGE OUTLINE

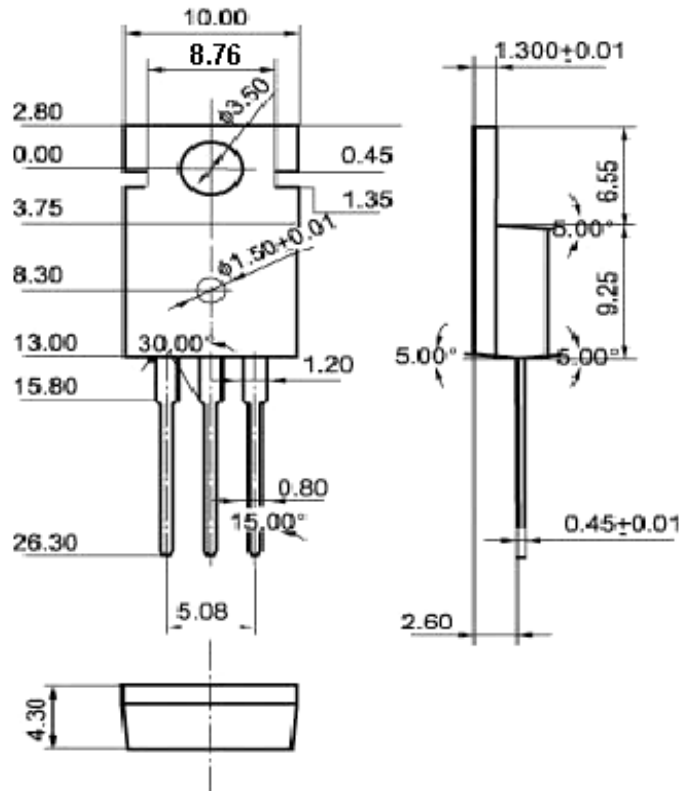

Fig.2 Outline dimensions

Silicon PNP Power Transistors

TIP42/42A/42B/42C

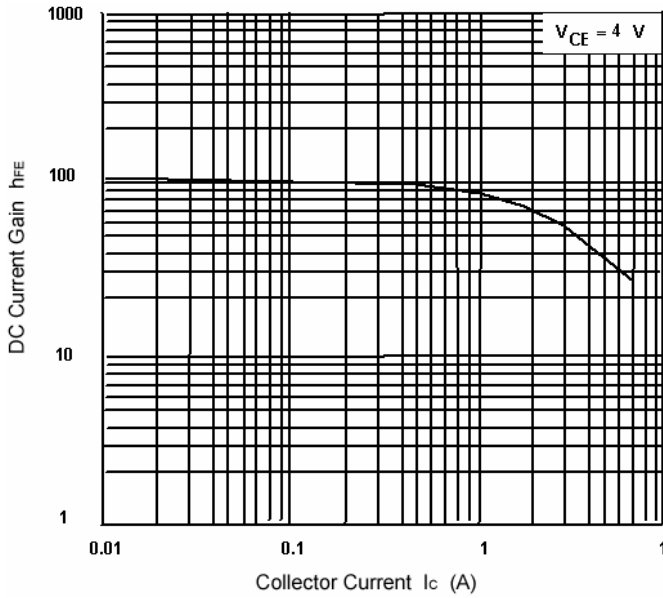

Fig.3 DC current Gain

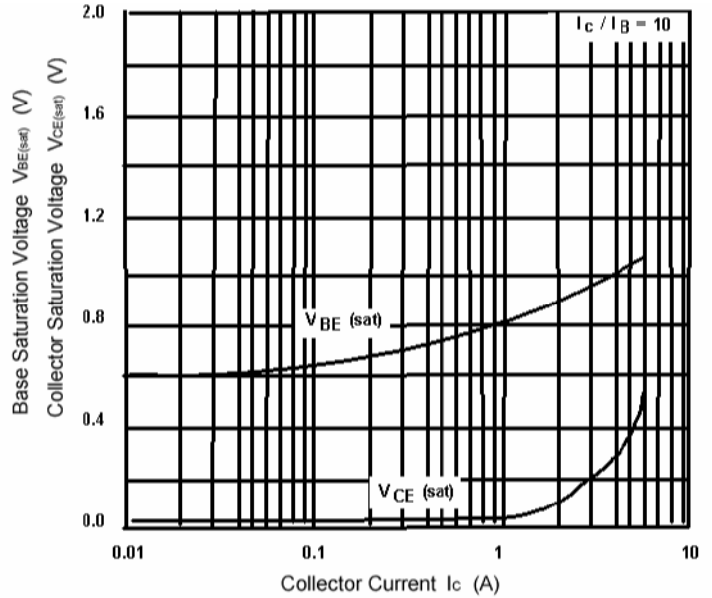

Fig.4 Base-Emitter Saturation Voltage
Collector-Emitter Saturation Voltage

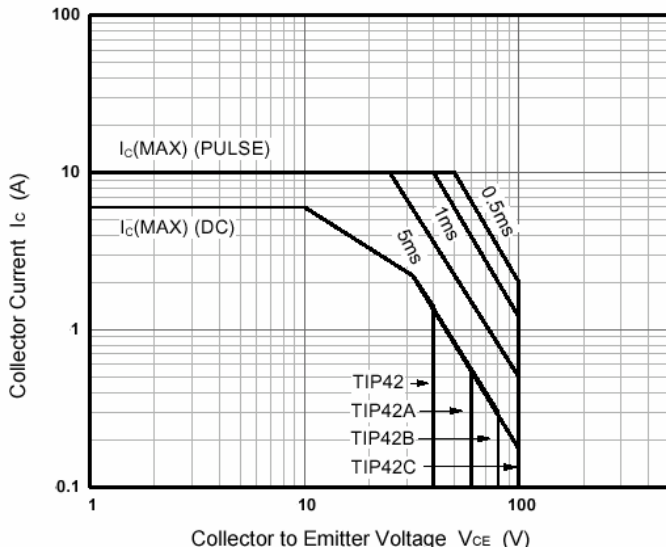

Fig.5 Safe Operating Area