

**52458 Dual Current-to-Current Opto-Isolator,  
High Temperature (200°C)**



**Features:**

- Hermetically Sealed Package
- Optically Coupled
- Input/Output Isolation Tested to 1000 VDC
- 200°C Operation

**Applications:**

- Signal Isolation

**DESCRIPTION**

The 52458 is a Current-to-Current Opto-Isolator designed for high temperature applications to 200°C.

Functionally, the device operates as a Current-to-Current Transformer with an output current proportional to the input current. The current transfer ratio is tightly controlled for temperatures from 25°C through 200°C.

**ABSOLUTE MAXIMUM RATINGS**

Continuous Input Current .....	20mA
Storage Temperature Range .....	-65°C to +200°C
Operating Temperature.....	-55°C to +200°C
Lead Solder Temperature for 10 seconds .....	300°C
Reverse Input Voltage .....	6 VDC

**RECOMMENDED OPERATING CONDITIONS:**

Parameter	Symbol	Min.	Max.	Units
Output Voltage	$V_O$		1.0	VDC
Input Current	$I_{F(ON)}$	5	15	mA
Input Voltage	$V_F$	1.1	1.6	VDC
Operating Case Temperature	$T_C$	-55	200	°C

**Micropac Industries** cannot assume any responsibility for any circuits shown or represent that they are free from patent infringement. **Micropac** reserves the right to make changes at any time in order to improve design and to supply the best product possible.

**ELECTRICAL SPECIFICATIONS**

T<sub>C</sub>= 25°C to +200°C unless otherwise specified

Parameter	Sym.	Min.	Typ.*	Max.	Units	Test Conditions	Notes
Input / Output Forward Voltage	V <sub>F</sub>	—	1.6	2.2	VDC	I <sub>F</sub> = 10 mA	
Input / Output Reverse Breakdown Voltage	V <sub>R</sub>	6	40	—	VDC	I <sub>R</sub> = 10 μA	
Input-Output Leakage	I <sub>I-O</sub>	—	—	1	μA	RH ≤ 45%, t = 5 s V <sub>I-O</sub> = 1000 VDC T <sub>C</sub> = 25°C	1,2
Turn-On Time	t <sub>ON</sub>	—	150		ns	I <sub>F</sub> = 2.5 mA E <sub>O</sub> = OV, shorted NOTE 4	
Turn-Off time	t <sub>OFF</sub>	—	100		ns		
Rise Time	t <sub>R</sub>	—	130		ns		3
Fall Time	t <sub>F</sub>	—	90		ns		
Output Current			80		μA	I <sub>F</sub> = 10 mA	

**Notes:**

1. Input pins are shorted together and output pins are shorted together.
2. Input-output potential applied momentarily, not an operating condition.
3. Rise time is measured from 10% to 90% of output current. Fall time is measured from 90% to 10% of output.
4. Measured values limited by the test Transimpedance circuit.

Micropac Industries cannot assume any responsibility for any circuits shown or represent that they are free from patent infringement. Micropac reserves the right to make changes at any time in order to improve design and to supply the best product possible.

Figure 1. Output Current vs. Temperature

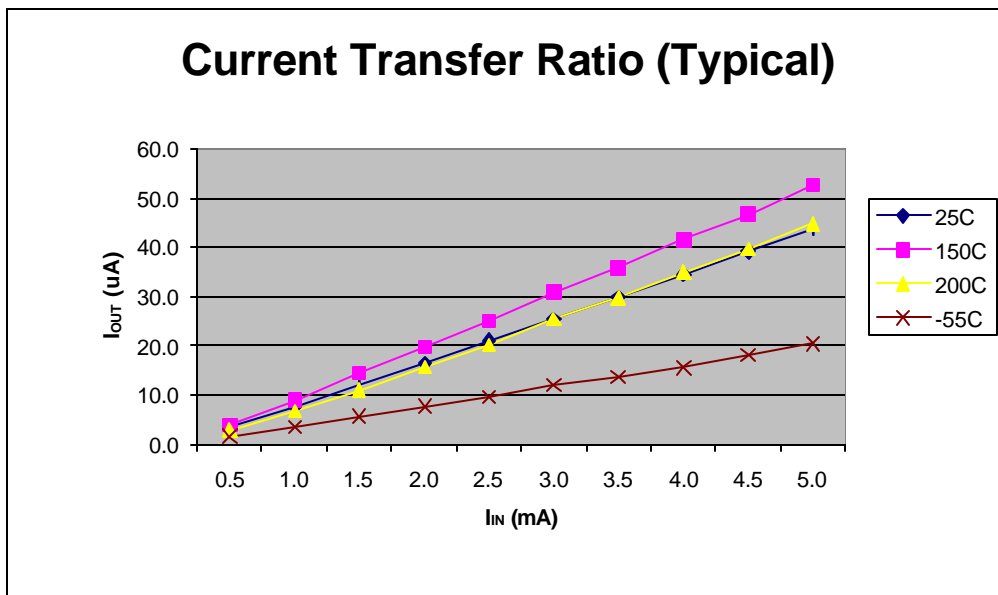
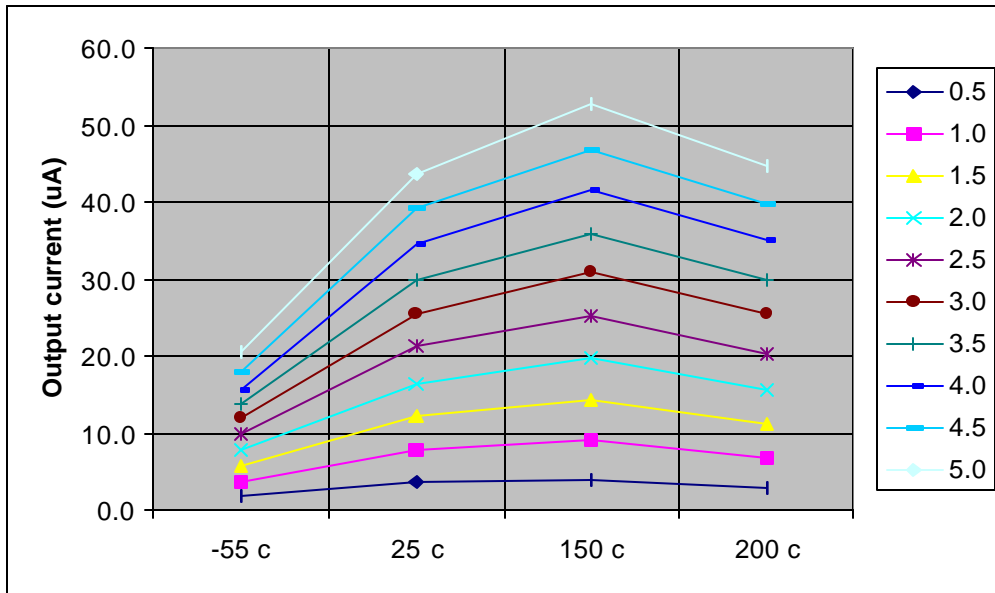

Figure 2. Output Current vs. Input Current (0.5mA – 5mA)

Micropac Industries cannot assume any responsibility for any circuits shown or represent that they are free from patent infringement. Micropac reserves the right to make changes at any time in order to improve design and to supply the best product possible.

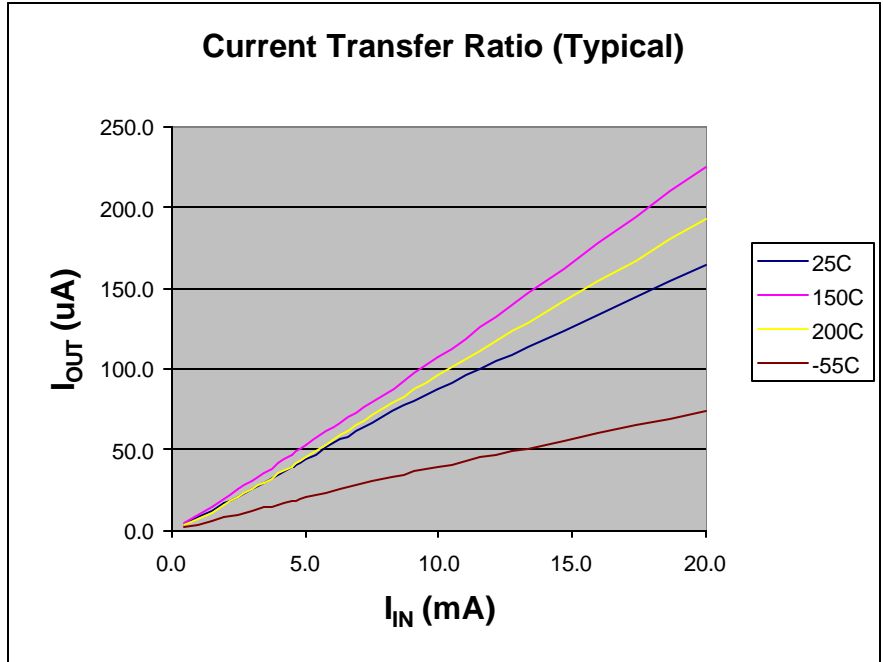

Figure 3. Output Current vs. Input Current (0.5mA – 20mA)

Pin	Function
1	+ in (section 1)
2	- in (section 1)
3	- out (section 2)
4	+ out (section 2)
5	+ in (section 2)
6	- in (section 2)
7	- out (section 1)
8	+ out (section 1)

1. ESD symbol (Δ) indicates pin 1.

Table 1. Pin Outs

Micropac Industries cannot assume any responsibility for any circuits shown or represent that they are free from patent infringement. Micropac reserves the right to make changes at any time in order to improve design and to supply the best product possible.

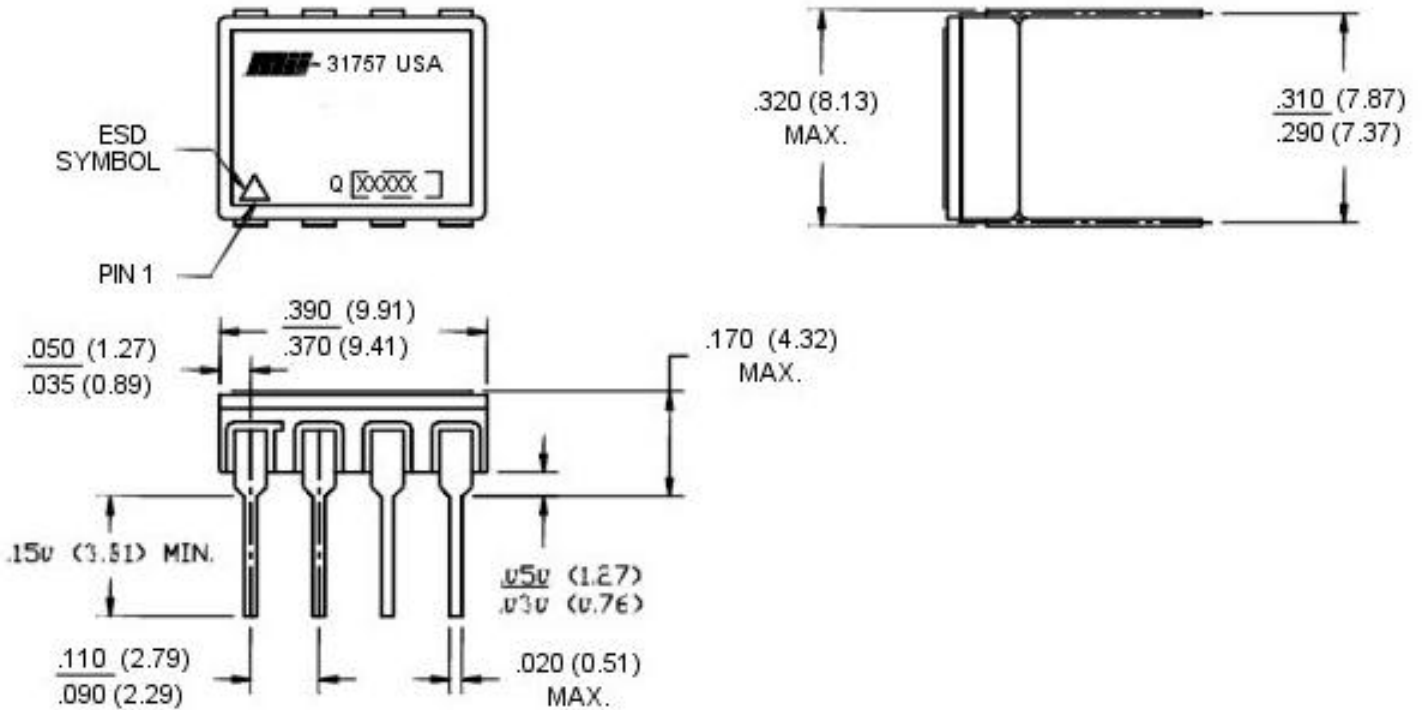

Note: Package is a Ceramic 8 Pin DIP

Figure 4. Case Outline

Application Notes:

52458.01 Isolated Current Monitor.

Figure 1 is a simple, moderately accurate circuit for monitoring an isolated load current. The heart of the circuit is the 52458 Opto Coupler.

The LED current of the coupler is the sum of 1; the bias current of Q2, Q1 / H<sub>FE</sub> (Q1) and Q3 / H<sub>FE</sub> (Q3) and 2; the collector current of Q1. Q1 and Q3 form a current mirror with an Emitter current ratio of R3 / R2.

A Q3 emitter current of 0.5A represents a 0.010A current at the emitter of Q1 and a total load current of 0.510A.

The OP Amp output voltage is the output current of the 52458 Opto Coupler times the R FEEDBACK value. In this circuit case, 1µA of Detector current produces a 0.1V output.

The total circuit then has a transfer value of (10mA of LED current = 510mA load current) producing 80µA of Detector current x 100k Ohm = 8V output. This gives 8V output for a load current of 510mA or a sensitivity of 1 Volt per 63.75mA.

Micropac Industries cannot assume any responsibility for any circuits shown or represent that they are free from patent infringement. Micropac reserves the right to make changes at any time in order to improve design and to supply the best product possible.

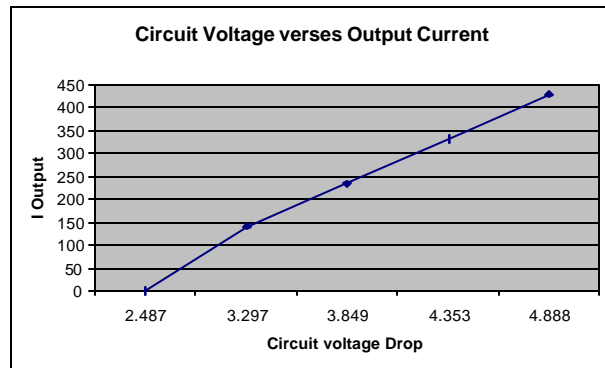
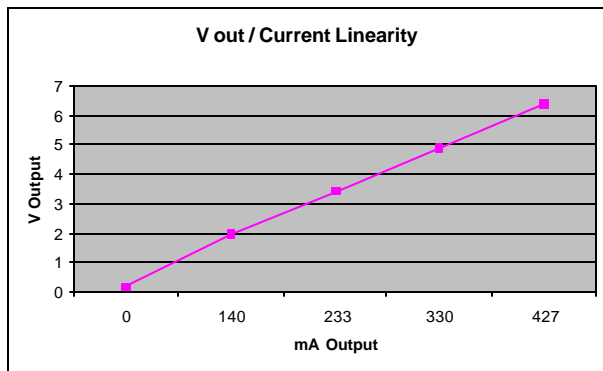
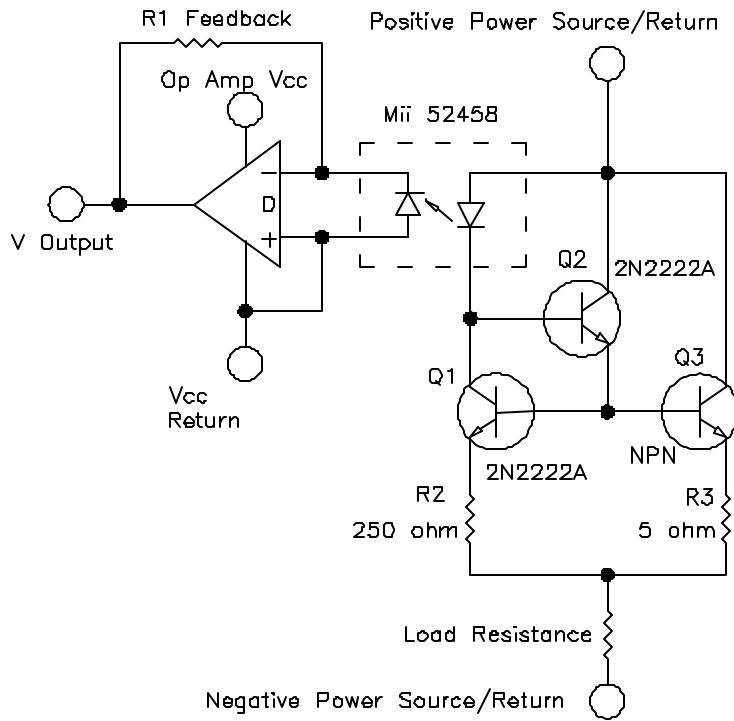

**Micropac Industries** cannot assume any responsibility for any circuits shown or represent that they are free from patent infringement. **Micropac** reserves the right to make changes at any time in order to improve design and to supply the best product possible.

The following chart illustrates the Optocoupler output as a function of Load current for the circuit of Figure 1.

Vin Volts	I Load mA	Voltage across Power Circuit	V Out
10	0	2.487	.12
10	140	3.297	1.95
10	233	3.849	3.43
10	330	4.353	4.87
10	427	4.888	6.37
30	0	2.517	.19
30	140	3	1.96
30	233	3.837	3.42
30	330	4.376	4.89
30	427	4.876	6.36

The following chart illustrates the effects of temperature on the Coupler output.

Vin Volts	I Load mA	Temp. Deg, C	I Out uA
20	0.33	25	48.8
20	0.33	125	48.7
20	0.33	150	47

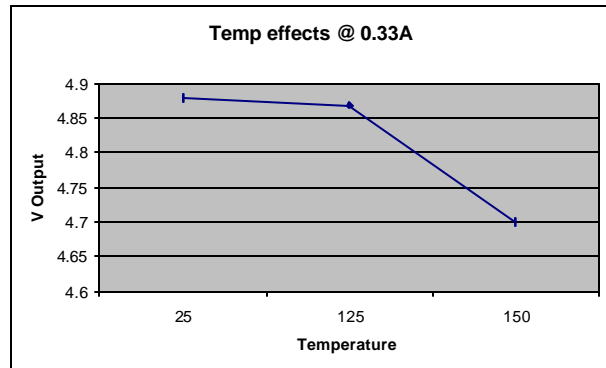
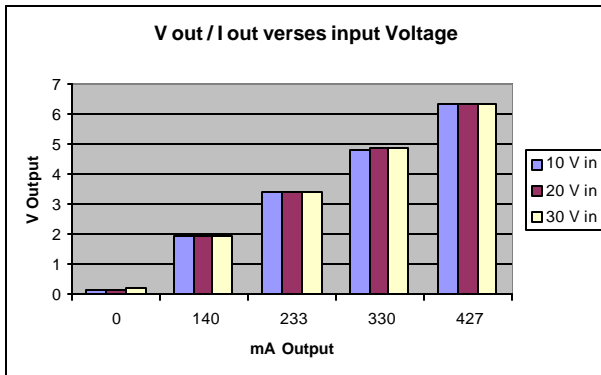

Micropac Industries cannot assume any responsibility for any circuits shown or represent that they are free from patent infringement. Micropac reserves the right to make changes at any time in order to improve design and to supply the best product possible.