

## 74F365 Hex Buffer/Driver with 3-STATE Outputs

### General Description

The 'F365 is a hex buffer and line driver designed to be employed as a memory and address driver, clock driver and bus-oriented transmitter/receiver.

### Features

- 3-STATE buffer outputs
- Outputs sink 64 mA
- Bus-oriented

### Ordering Code:

Commercial	Military	Package Number	Package Description
74F365PC		N16E	16-Lead (0.300" Wide) Molded Dual-In-Line
	54F365DM (Note 2)	J16A	16-Lead Ceramic Dual-In-Line
74F365SC (Note 1)		M16A	16-Lead (0.150" Wide) Molded Small Outline, JEDEC
	54F365FM (Note 2)	W16A	16-Lead Cerpack
	54F365LM (Note 2)	E20A	20-Lead Ceramic Leadless Chip Carrier, Type C

**Note 1:** Devices also available in 13" reel. Use suffix = SCX.

**Note 2:** Military grade device with environmental and burn-in processing. Use suffix = DMQB, FMQB and LMQB.

### Logic Symbol

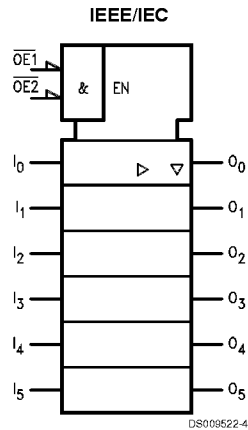

## Connection Diagrams

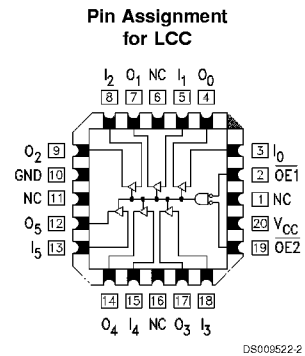
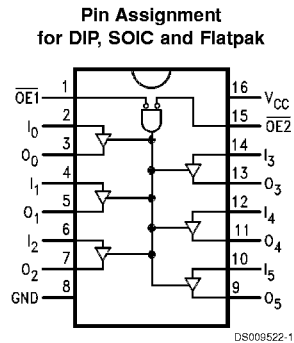

## Unit Loading/Fan Out

Pin Names	Description	54F/74F	
		U.L. HIGH/LOW	Input $I_{IH}/I_{IL}$ Output $I_{OH}/I_{OL}$
$\overline{OE}_1, \overline{OE}_2$	Output Enable Input (Active LOW)	1.0/0.033	20 $\mu$ A/20 $\mu$ A
$I_n$	Inputs	1.0/0.033	20 $\mu$ A/20 $\mu$ A
$O_n$	Outputs	600/106.6 (80)	-12 mA/64 mA (48 mA)

## Function Table

Inputs			Output
$\overline{OE}_1$	$\overline{OE}_2$	I	O
L	L	L	L
L	L	H	H
X	H	X	Z
H	X	X	Z

L = LOW Voltage Level  
H = HIGH Voltage Level  
X = Immaterial  
Z = High Impedance

## Absolute Maximum Ratings (Note 3)

Storage Temperature	-65°C to +150°C
Ambient Temperature under Bias	-55°C to +125°C
Junction Temperature under Bias	-55°C to +175°C
Plastic	-55°C to +150°C
V <sub>CC</sub> Pin Potential to Ground Pin	-0.5V to +7.0V
Input Voltage (Note 4)	-0.5V to +7.0V
Input Current (Note 4)	-30 mA to +5.0 mA
Voltage Applied to Output in HIGH State (with V <sub>CC</sub> = 0V)	
Standard Output	-0.5V to V <sub>CC</sub>
3-STATE Output	-0.5V to +5.5V
Current Applied to Output	

in LOW State (Max)

twice the rated I<sub>OL</sub> (mA)

## Recommended Operating Conditions

Free Air Ambient Temperature	
Military	-55°C to +125°C
Commercial	0°C to +70°C
Supply Voltage	
Military	+4.5V to +5.5V
Commercial	+4.5V to +5.5V

**Note 3:** Absolute maximum ratings are values beyond which the device may be damaged or have its useful life impaired. Functional operation under these conditions is not implied.

**Note 4:** Either voltage limit or current limit is sufficient to protect inputs.

## DC Electrical Characteristics

Symbol	Parameter	54F/74F			Units	V <sub>CC</sub>	Conditions
		Min	Typ	Max			
V <sub>IH</sub>	Input HIGH Voltage	2.0			V		Recognized as a HIGH Signal
V <sub>IL</sub>	Input LOW Voltage			0.8	V		Recognized as a LOW Signal
V <sub>CD</sub>	Input Clamp Diode Voltage			-1.2	V	Min	I <sub>IN</sub> = -18 mA
V <sub>OH</sub>	Output HIGH Voltage	54F 10% V <sub>CC</sub>	2.4		V	Min	I <sub>OH</sub> = -3 mA
		54F 10% V <sub>CC</sub>	2.0				I <sub>OH</sub> = -12 mA
		74F 10% V <sub>CC</sub>	2.4				I <sub>OH</sub> = -3 mA
		74F 10% V <sub>CC</sub>	2.0				I <sub>OH</sub> = -15 mA
		74F 5% V <sub>CC</sub>	2.7				I <sub>OH</sub> = -3 mA
V <sub>OL</sub>	Output LOW Voltage	54F 10% V <sub>CC</sub>		0.55	V	Min	I <sub>OL</sub> = 48 mA
		74F 10% V <sub>CC</sub>		0.55			I <sub>OL</sub> = 64 mA
I <sub>IH</sub>	Input HIGH Current			20	μA	Max	V <sub>IN</sub> = 2.7V
I <sub>BVI</sub>	Input HIGH Current Breakdown Test			100	μA	0.0	V <sub>IN</sub> = 7.0V
I <sub>IL</sub>	Input LOW Current			-20	μA	Max	V <sub>IN</sub> = 0.5V
I <sub>OZH</sub>	Output Leakage Current			50	μA	Max	V <sub>OUT</sub> = 2.7V
I <sub>OZL</sub>	Output Leakage Current			-50	μA	Max	V <sub>OUT</sub> = 0.5V
I <sub>OS</sub>	Output Short-Circuit Current	-100	-225		mA	Max	V <sub>OUT</sub> = 0V
I <sub>CEX</sub>	Output HIGH Leakage Current			250	μA	Max	V <sub>OUT</sub> = V <sub>CC</sub>
I <sub>ZZ</sub>	Bus Drainage Test			500	μA	0.0V	V <sub>OUT</sub> = 5.25V
I <sub>CCH</sub>	Power Supply Current		25	35	mA	Max	V <sub>O</sub> = HIGH
I <sub>CCL</sub>	Power Supply Current		44	62	mA	Max	V <sub>O</sub> = LOW
I <sub>CCZ</sub>	Power Supply Current		35	48	mA	Max	V <sub>O</sub> = HIGH Z

## AC Electrical Characteristics

Symbol	Parameter	74F			54F		74F		Units
		T <sub>A</sub> = +25°C V <sub>CC</sub> = +5.0V C <sub>L</sub> = 50 pF			T <sub>A</sub> , V <sub>CC</sub> = Mil C <sub>L</sub> = 50 pF		T <sub>A</sub> , V <sub>CC</sub> = Com C <sub>L</sub> = 50 pF		
		Min	Typ	Max	Min	Max	Min	Max	
t <sub>PLH</sub>	Propagation Delay	2.5	4.6	6.5	2.0	7.0	2.0	7.0	ns
t <sub>PHL</sub>	I <sub>n</sub> to O <sub>n</sub>	2.5	4.9	7.0	2.0	7.0	2.0	7.5	
t <sub>PZH</sub>	Enable Time	2.5	5.1	9.5	2.0	8.5	2.5	10.0	ns
t <sub>PZL</sub>		2.5	5.7	9.0	2.0	8.5	2.5	9.5	
t <sub>PHZ</sub>	Disable Time	2.0	3.6	6.5	1.5	6.5	2.0	7.0	ns
t <sub>PLZ</sub>		2.0	4.4	6.5	1.5	9.0	2.0	7.0	

## Ordering Information

The device number is used to form part of a simplified purchasing code where the package type and temperature range are defined as follows:

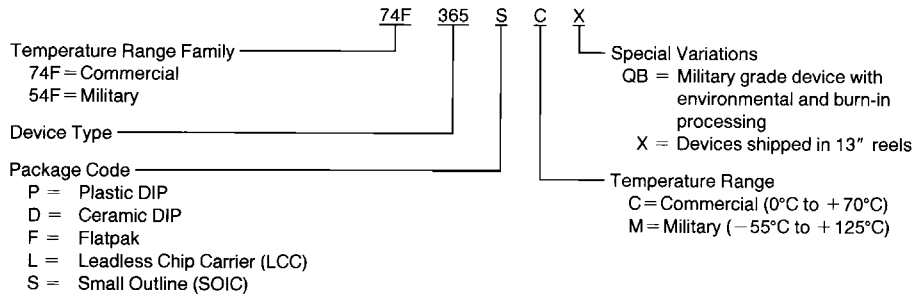

DS009522-5

## Physical Dimensions inches (millimeters) unless otherwise noted

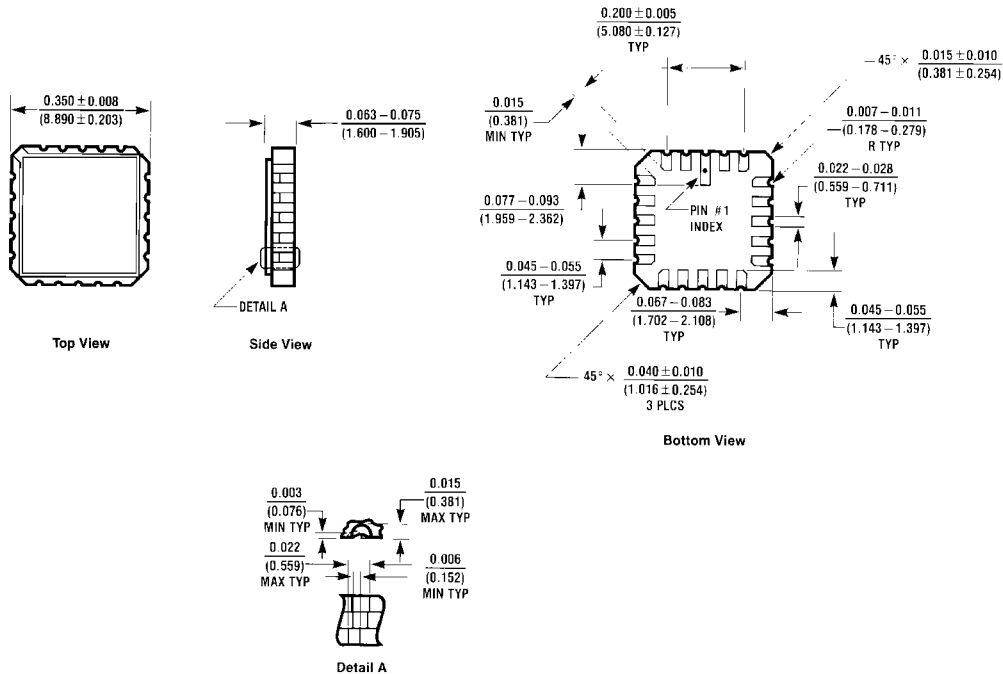

ESDA (REV. 11)

**20-Lead Ceramic Leadless Chip Carrier (L)  
 Package Number E20A**

**Physical Dimensions** inches (millimeters) unless otherwise noted (Continued)

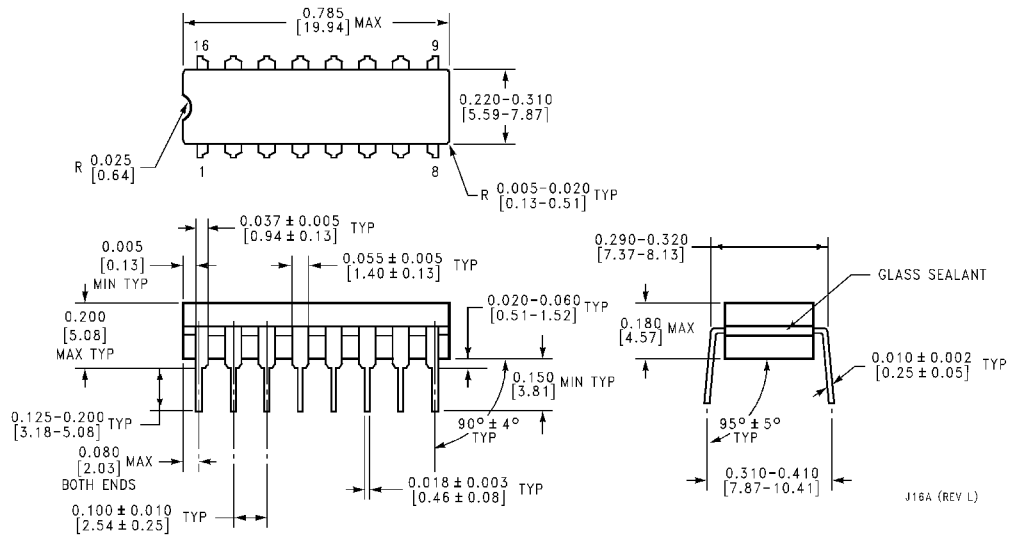

**16-Lead Ceramic Dual-In-Line Package (D)  
Package Number J16A**

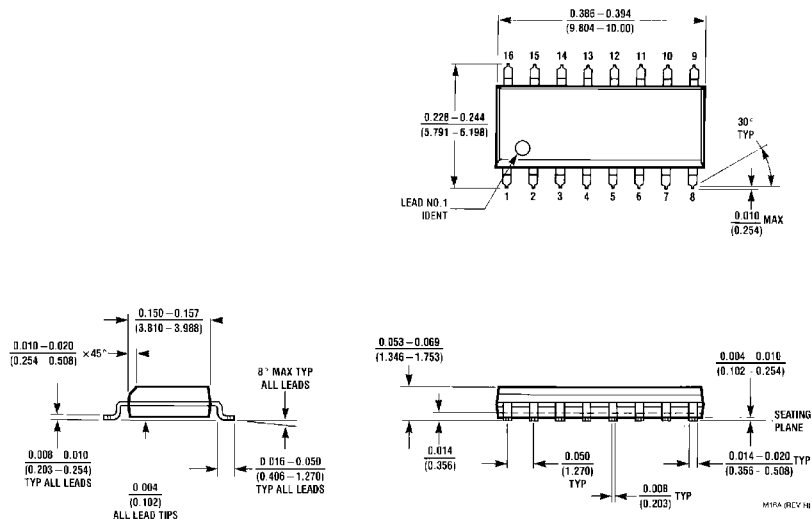

**16-Lead (0.150" Wide) Molded Small Outline Package, JEDEC (S)  
Package Number M16A**



**LIFE SUPPORT POLICY**

FAIRCHILD'S PRODUCTS ARE NOT AUTHORIZED FOR USE AS CRITICAL COMPONENTS IN LIFE SUPPORT DEVICES OR SYSTEMS WITHOUT THE EXPRESS WRITTEN APPROVAL OF THE PRESIDENT OF FAIRCHILD SEMICONDUCTOR CORPORATION. As used herein:

1. Life support devices or systems are devices or systems which, (a) are intended for surgical implant into the body, or (b) support or sustain life, and (c) whose failure to perform when properly used in accordance with instructions for use provided in the labeling, can be reasonably expected to result in a significant injury to the user.
2. A critical component in any component of a life support device or system whose failure to perform can be reasonably expected to cause the failure of the life support device or system, or to affect its safety or effectiveness.

**Fairchild Semiconductor Corporation Americas**  
Customer Response Center  
Tel: 1-888-522-5372

**Fairchild Semiconductor Europe**  
Fax: +49 (0) 1 80-530 85 86  
Email: europe.support@nsc.com  
Deutsch Tel: +49 (0) 8 141-35-0  
English Tel: +44 (0) 1 793-85-68-56  
Italy Tel: +39 (0) 2 57 5631

**Fairchild Semiconductor Hong Kong Ltd.**  
13th Floor, Straight Block,  
Ocean Centre, 5 Canton Rd.  
Tsimshatsui, Kowloon  
Hong Kong  
Tel: +852 2737-7200  
Fax: +852 2314-0061

**National Semiconductor Japan Ltd.**  
Tel: 81-3-5620-6175  
Fax: 81-3-5620-6179

[www.fairchildsemi.com](http://www.fairchildsemi.com)