

## FEATURES AND SPECIFICATIONS



# Manual Ribbon Cable Standard Press and Tool Kit for SL™

The Molex SL Ribbon Cable Terminator Kit is designed to be used in the Molex Manual Standard Press. This tool system terminates the SL IDT (Insulation Displacement Technology) 70400 and 70475 connectors onto pre-notched ribbon cable.

This tool system provides an effective and flexible method of termination. The Molex Manual Press has a full-cycle ratchet arm which assures the quality of the termination. This tool system will also accommodate 2 to 25 circuits which provides flexibility. It also features adjustable cable guides and stop for repeatable cable and connector alignment.

**Operation:** The operator loads a connector into the nest of the terminator kit (which is installed in the Molex Manual Standard Press), sets the cable stop and positions the cable over the terminals. The operator cycles the ratch arm on the press to complete the termination and then removes the harness. The terminals must be pushed into the housing by hand and then the carrier strip must be broken off by hand. The operation is complete.

The product rate of this tool system is approximately 150 assemblies per hour depending on operator skill and application.

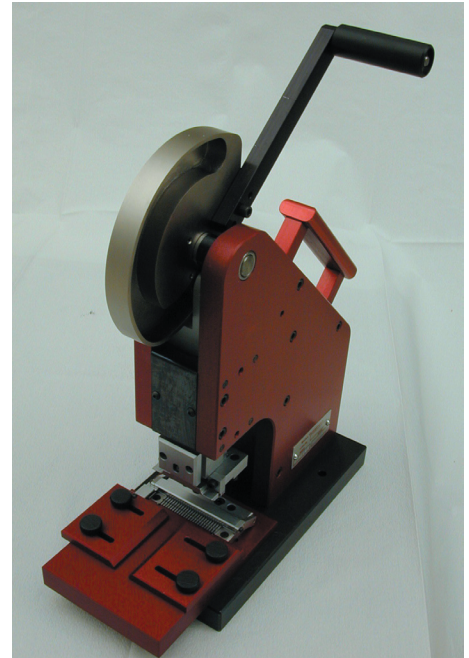

### Features and Benefits

- Adjustable for 2 to 25 circuits, which provides for production flexibility
- Tooling Termination Kit easily mounted in the Molex Manual Standard Press and can be quickly removed which will increase productivity and reduce change over time
- Full-cycle ratch assures quality terminations
- Adjustable cable guides and stop for repeatable cable/connector alignment for various cable size requirements which lower overall cost through reduced tooling inventory
- No air or electricity required which reduce overhead cost
- Bench mounted operation that requires minimal space
- Molex Manual Standard Press accepts many Molex tooling kits for various Molex products that provide flexibility in the changing marketplace and reduces overall cost

### Mechanical

- Dimensions: With Press and Tool Kit**
- Height—533.00mm (21.000")
  - Width—152.00mm (6.000")
  - Depth—408.00mm (16.100")
  - Weight—27.2kg (60 lb)
- Tool Kit Only:**
- Height—51.00mm (2.000")
  - Width—127.00mm (5.000")
  - Depth—178.00mm (7.000")
  - Weight—2.5kg (5.5 lb)

## ORDERING INFORMATION

Order No.	Description
62201-6600	Tool Kit Only
11-31-6356	Molex Manual Standard Press

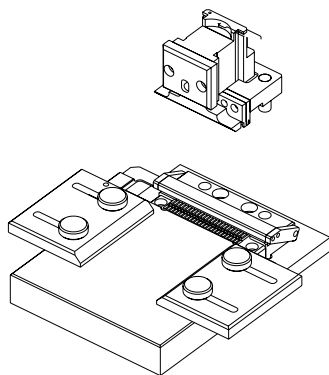

62201-6600

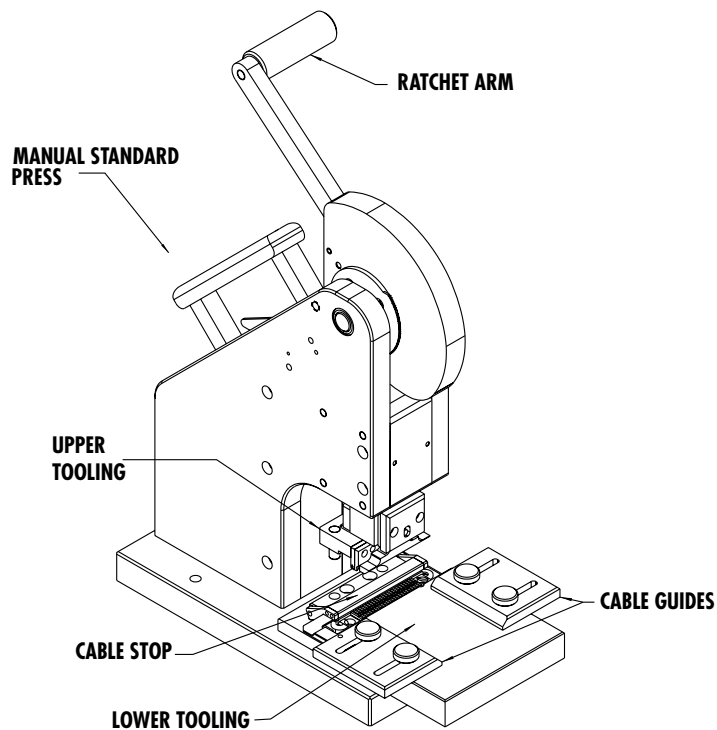

**Americas Headquarters**  
Lisle, Illinois 60532 U.S.A.  
1-800-78MOLEX  
amerinfo@molex.com

**Far East North Headquarters**  
Yamato, Kanagawa, Japan  
81-462-65-2324  
feninfo@molex.com

**Far East South Headquarters**  
Jurong, Singapore  
65-6-268-6868  
fesinfo@molex.com

**European Headquarters**  
Munich, Germany  
49-89-413092-0  
eurinfo@molex.com

**Corporate Headquarters**  
2222 Wellington Ct.  
Lisle, IL 60532 U.S.A.  
630-969-4550  
Fax: 630-969-1352

Visit our website at [www.molex.com](http://www.molex.com)