

The Molex Ground Clip applicator is designed to crimp a Molex 42172 family ground clip to discrete wire. This applicator is an improved version and replaces the 11-18-2139 Mini-Mac. This applicator works in the Molex TM-2000 Universal Press and in most industry standard presses. This improved and enhanced tool address all of the field requests for a more robust tool.

**Design Enhancements**

1. Heavy duty face plate will prevent plate fractures and reduce down time.
2. TrackAdjust allows applicator to remain in the press during adjustment which reduces setup time.
3. Heavy duty feed finger will provide a longer life and require less replacement than standard feed finger.
4. Conductor punch designed for a longer life cycle.
5. Insulation punch designed for a longer life cycle.
6. Plunger striker designed with two points of contact to ensure even cut-off load.
7. Cut-off plunger has dual cutoff and designed for longer life cycle and cuts carrier into manageable pieces.
8. Plunger retainer designed for a longer life cycle.
9. Scrap deflector ensures that terminal strip does not fall on anvils.
10. Insulation and conductor anvil have individual design.

11. Larger wire stop design to increase target for operator.

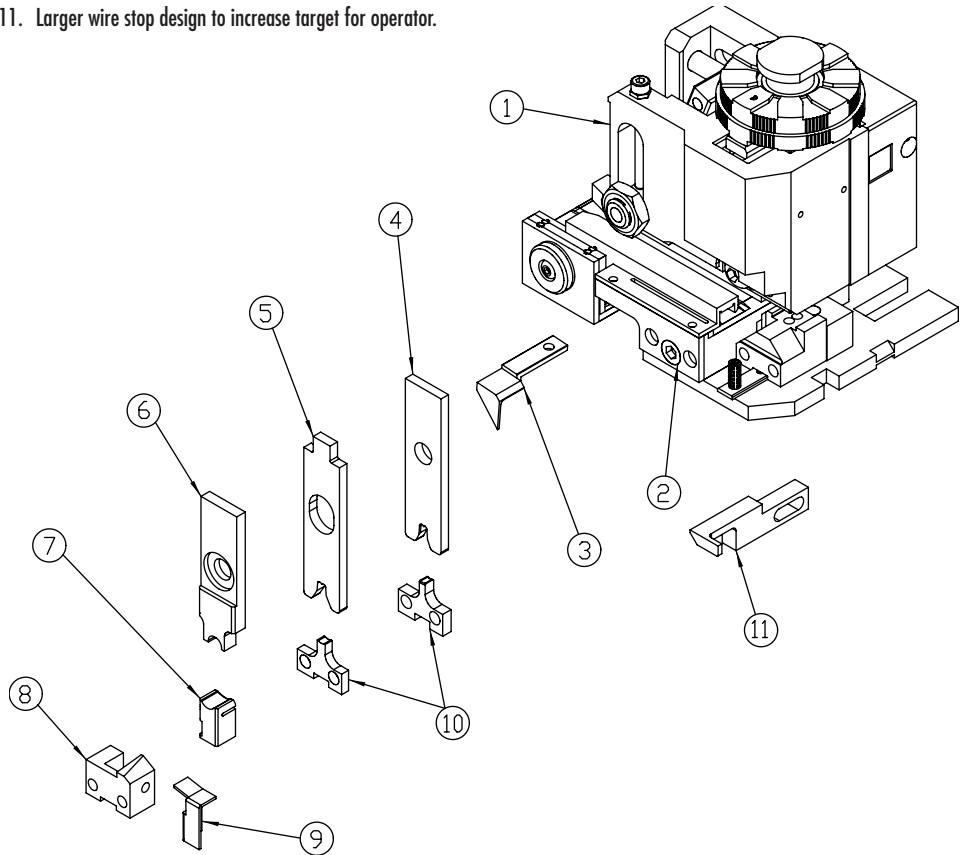

**Features and Benefits**

- Compatible with the Molex TM-2000 Universal Press and most industry standard presses
- Quick set-up time plus the crimp height, track and feed adjustments can be preset in applicator
- Conductor and insulation rings allow quick adjustment for conductor and insulation diameter change
- Directly adapts to most automatic wire processing machines
- Applicator designed to industry standard mounting and shut height 135.80mm (5.346")

**Mechanical**

Dimensions: Height—152mm (6.0")  
 Width—132mm (5.2")  
 Depth—101mm (4.0")  
 Weight: Gross—5.4 kg (12 lbs.)  
 Unpacked—4.1 kb (9 lbs.)  
 Mechanics: Stroke Length—28.5mm (1.125") and 41.3mm (1.625")  
 Shut Height—135.8mm (5.346")  
 Processing Capability: 2500 terminations per hour, depending on operator's skill and application.

**ORDERING INFORMATION**

Order No.	Description	For Use With	Used with Terminal Series
63830-6000	Ground Clip Applicator	TM-2000 Press	42172-A, B, C, F
63830-6100	Ground Clip Applicator	TM-2000 Press	42172-AA, BB, CC

**Americas Headquarters**  
 Lisle, Illinois 60532 U.S.A.  
 1-800-78MOLEX  
 amerinfo@molex.com

**Far East North Headquarters**  
 Yamato, Kanagawa, Japan  
 81-462-65-2324  
 feninfo@molex.com

**Far East South Headquarters**  
 Jurong, Singapore  
 65-6-268-6868  
 fesinfo@molex.com

**European Headquarters**  
 Munich, Germany  
 49-89-413092-0  
 eurinfo@molex.com

**Corporate Headquarters**  
 2222 Wellington Ct.  
 Lisle, IL 60532 U.S.A.  
 630-969-4550  
 Fax: 630-969-1352