

BCD TO DECIMAL DECODER (1-OF-10)

FEATURES

- Mutually exclusive outputs
- 1-of-8 demultiplexing capability
- Outputs disabled for input codes above nine
- Output capability: standard
- I_{CC} category: MSI

GENERAL DESCRIPTION

The 74HC/HCT42 are high-speed Si-gate CMOS devices and are pin compatible with low power Schottky TTL (LSSTTL). They are specified in compliance with JEDEC standard no. 7A.

The 74HC/HCT42 decoders accept four active HIGH BCD inputs and provide 10 mutually exclusive active LOW outputs. The active LOW outputs facilitate addressing other MSI circuits with active LOW input enables.

The logic design of the "42" ensures that all outputs are HIGH when binary codes greater than nine are applied to the inputs.

The most significant input (A₃) produces a useful inhibit function when the "42" is used as a 1-of-8 decoder. The A₃ input can also be used as the data input in an 8-output demultiplexer application.

SYMBOL	PARAMETER	CONDITIONS	TYPICAL		UNIT
			HC	HCT	
t _{PHL} / t _{PLH}	propagation delay A _n to \bar{Y}_n	C _L = 15 pF V _{CC} = 5 V	14	17	ns
C _I	input capacitance		3.5	3.5	pF
C _{PD}	power dissipation capacitance per package	notes 1 and 2	37	37	pF

GND = 0 V; T_{amb} = 25 °C; t_r = t_f = 6 ns

Notes

1. C_{PD} is used to determine the dynamic power dissipation (P_D in μW):

$$P_D = C_{PD} \times V_{CC}^2 \times f_i + \sum (C_L \times V_{CC}^2 \times f_o)$$
 where:
 f_i = input frequency in MHz C_L = output load capacitance in pF
 f_o = output frequency in MHz V_{CC} = supply voltage in V
 Σ (C_L × V_{CC}² × f_o) = sum of outputs
2. For HC the condition is V_I = GND to V_{CC}
 For HCT the condition is V_I = GND to V_{CC} - 1.5 V

PACKAGE OUTLINES

16-lead DIL; plastic (SOT38Z).
 16-lead mini-pack; plastic (SO16; SOT109A).

PIN DESCRIPTION

PIN NO.	SYMBOL	NAME AND FUNCTION
1, 2, 3, 4, 5, 6, 7, 9, 10, 11	\bar{Y}_0 to \bar{Y}_9	multiplexer outputs
8	GND	ground (0 V)
15, 14, 13, 12	A ₀ to A ₃	data inputs
16	V _{CC}	positive supply voltage

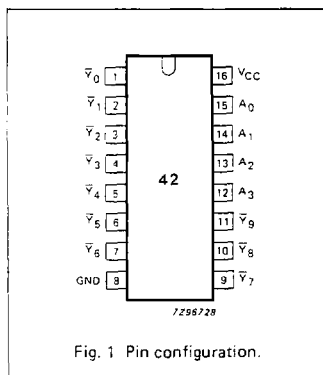

Fig. 1 Pin configuration.

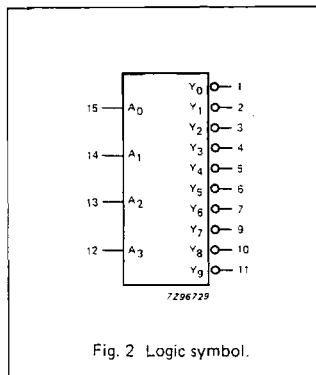

Fig. 2 Logic symbol.

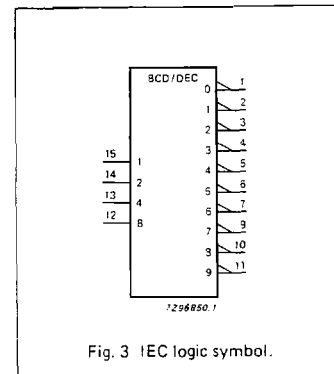

Fig. 3 IEC logic symbol.

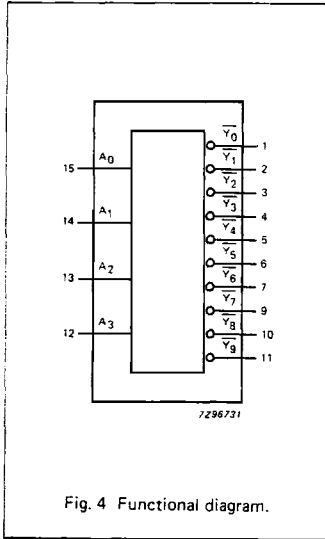

Fig. 4 Functional diagram.

FUNCTION TABLE

INPUTS				OUTPUTS									
A ₃	A ₂	A ₁	A ₀	\bar{Y}_0	\bar{Y}_1	\bar{Y}_2	\bar{Y}_3	\bar{Y}_4	\bar{Y}_5	\bar{Y}_6	\bar{Y}_7	\bar{Y}_8	\bar{Y}_9
L	L	L	L	L	H	H	H	H	H	H	H	H	H
L	L	L	H	L	H	H	L	H	H	H	H	H	H
L	L	L	L	H	H	H	H	L	H	H	H	H	H
L	L	L	H	H	H	H	L	H	H	H	H	H	H
L	H	L	L	H	H	H	H	L	H	H	H	H	H
L	H	L	H	L	H	H	H	H	L	H	H	H	H
L	H	H	L	H	H	H	H	H	H	L	H	H	H
L	H	H	H	L	H	H	H	H	H	H	L	H	H
H	L	L	L	H	H	H	H	H	H	H	H	L	L
H	L	L	H	L	H	H	H	H	H	H	H	H	L
H	L	H	L	H	H	H	H	H	H	H	H	H	L
H	L	H	H	L	H	H	H	H	H	H	H	H	L
H	H	L	L	H	H	H	H	H	H	H	H	H	H
H	H	L	H	L	H	H	H	H	H	H	H	H	H
H	H	H	L	H	H	H	H	H	H	H	H	H	H
H	H	H	H	L	H	H	H	H	H	H	H	H	H
H	H	L	L	H	H	H	H	H	H	H	H	H	H
H	H	L	H	L	H	H	H	H	H	H	H	H	H
H	H	H	L	H	H	H	H	H	H	H	H	H	H
H	H	H	H	L	H	H	H	H	H	H	H	H	H

H = HIGH voltage level
L = LOW voltage level

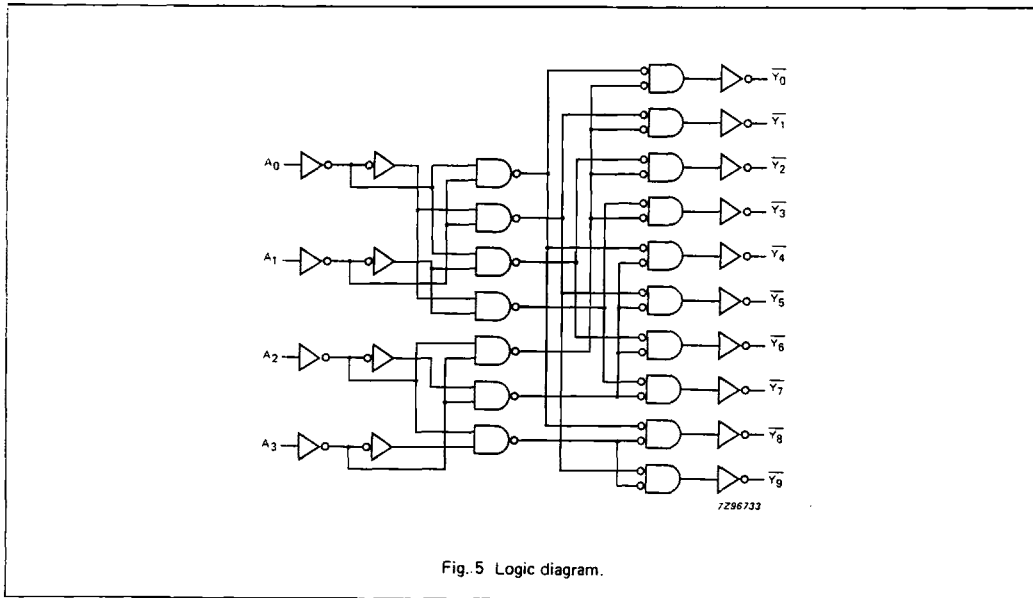

Fig. 5 Logic diagram.

DC CHARACTERISTICS FOR 74HC

For the DC characteristics see chapter "HCMOS family characteristics", section "Family specifications".

Output capability: standard
I_{CC} category: MSI**AC CHARACTERISTICS FOR 74HC**GND = 0 V; t_r = t_f = 6 ns; C_L = 50 pF

SYMBOL	PARAMETER	T _{amb} (°C)						UNIT	TEST CONDITIONS		
		74HC							V _{CC} V	WAVEFORMS	
		+25			-40 to +85		-40 to +125				
		min.	typ.	max.	min.	max.	min.				max.
t _{PHL} / t _{PLH}	propagation delay A _n to \bar{Y}_n		47 17 14	150 30 26		190 38 33		225 45 38	ns	2.0 4.5 6.0	Fig. 6
t _{THL} / t _{TLH}	output transition time		19 7 6	75 15 13		95 19 16		110 22 19	ns	2.0 4.5 6.0	Fig. 6

DC CHARACTERISTICS FOR 74HCT

For the DC characteristics see chapter "HCMOS family characteristics", section "Family specifications".

Output capability: standard
I_{CC} category: MSI**Note to HCT types**The value of additional quiescent supply current (ΔI_{CC}) for a unit load of 1 is given in the family specifications.
To determine ΔI_{CC} per input, multiply this value by the unit load coefficient shown in the table below.

INPUT	UNIT LOAD COEFFICIENT
A _n	1.0

AC CHARACTERISTICS FOR 74HCTGND = 0 V; t_r = t_f = 6 ns; C_L = 50 pF

SYMBOL	PARAMETER	T _{amb} (°C)						UNIT	TEST CONDITIONS		
		74HCT							V _{CC} V	WAVEFORMS	
		+25			-40 to +85		-40 to +125				
		min.	typ.	max.	min.	max.	min.				max.
t _{PHL} / t _{PLH}	propagation delay A _n to \bar{Y}_n		20	35		44		53	ns	4.5	Fig. 6
t _{THL} / t _{TLH}	output transition time		7	15		19		22	ns	4.5	Fig. 6

AC WAVEFORMS

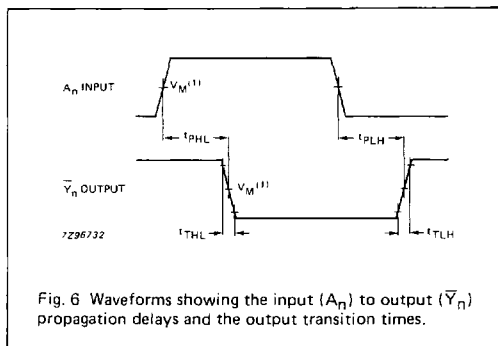

Note to AC waveforms

- (1) HC : $V_M = 50\%$; $V_I = \text{GND to } V_{CC}$.
- HCT: $V_M = 1.3 \text{ V}$; $V_I = \text{GND to } 3 \text{ V}$.