

Am29LV6402M

Data Sheet



July 2003

The following document specifies Spansion memory products that are now offered by both Advanced Micro Devices and Fujitsu. Although the document is marked with the name of the company that originally developed the specification, these products will be offered to customers of both AMD and Fujitsu.

Continuity of Specifications

There is no change to this datasheet as a result of offering the device as a Spansion product. Any changes that have been made are the result of normal datasheet improvement and are noted in the document revision summary, where supported. Future routine revisions will occur when appropriate, and changes will be noted in a revision summary.

Continuity of Ordering Part Numbers

AMD and Fujitsu continue to support existing part numbers beginning with "Am" and "MBM". To order these products, please use only the Ordering Part Numbers listed in this document.

For More Information

Please contact your local AMD or Fujitsu sales office for additional information about Spansion memory solutions.

Publication Number **27552** Revision **B** Amendment **0** Issue Date **September 17, 2003**



THIS PAGE LEFT INTENTIONALLY BLANK.

Am29LV6402M

128 Megabit (4 M x 32-Bit/8 M x 16-Bit) MirrorBit™ 3.0 Volt-only Uniform Sector Flash Memory with Versatile I/O™ Control

DISTINCTIVE CHARACTERISTICS

ARCHITECTURAL ADVANTAGES

- **Single power supply operation**
 - 3 volt read, erase, and program operations
- **Versatile/I/O™ control**
 - Device generates data output voltages and tolerates data input voltages on the CE# and DQ inputs/outputs as determined by the voltage on the V_{IO} pin; operates from 1.65 to 3.6 V
- **Manufactured on 0.23 μm MirrorBit™ process technology**
- **SecSi™ (Secured Silicon) Sector region**
 - 128-doubleword/256-word sector for permanent, secure identification through an 8-doubleword/16-word random Electronic Serial Number, accessible through a command sequence
 - May be programmed and locked at the factory or by the customer
- **Flexible sector architecture**
 - One hundred twenty-eight 32 Kdoubleword (64 Kword) sectors
- **Compatibility with JEDEC standards**
 - Provides pinout and software compatibility for single-power supply flash, and superior inadvertent write protection
- **100,000 erase cycles per sector**
- **20-year data retention at 125°C**

PERFORMANCE CHARACTERISTICS

- **High performance**
 - 100 ns access time
 - 30 ns page read times
 - 0.5 s typical sector erase time
 - 22 μs typical write buffer doubleword programming time: 16-doubleword/32-word write buffer reduces overall programming time for multiple-word updates

- 4-doubleword/8-word page read buffer
- 16-doubleword/32-word write buffer

- **Low power consumption (typical values at 3.0 V, 5 MHz)**

- 26 mA typical active read current
- 100 mA typical erase/program current
- 2 μA typical standby mode current

- **Package options**

- 80-ball Fortified BGA

SOFTWARE & HARDWARE FEATURES

- **Software features**

- Program Suspend & Resume: read other sectors before programming operation is completed
- Erase Suspend & Resume: read/program other sectors before an erase operation is completed
- Data# polling & toggle bits provide status
- Unlock Bypass Program command reduces overall multiple-word or byte programming time
- CFI (Common Flash Interface) compliant: allows host system to identify and accommodate multiple flash devices

- **Hardware features**

- Sector Group Protection: hardware-level method of preventing write operations within a sector group
- Temporary Sector Unprotect: V_{ID}-level method of changing code in locked sectors
- WP#/ACC input accelerates programming time (when high voltage is applied) for greater throughput during system production. Protects first or last sector regardless of sector protection settings
- Hardware reset input (RESET#) resets device
- Ready/Busy# output (RY/BY#) detects program or erase cycle completion

GENERAL DESCRIPTION

The Am29LV6402M consists of two 64 Mbit, 3.0 volt single power supply flash memory devices and is organized as 4,194,304 doublewords or 8,388,608 words. The device has a 32-bit wide data bus that can also function as an 16-bit wide data bus by using the WORD# input. The device can be programmed either in the host system or in standard EPROM programmers.

An access time of 100 or 110 ns is available. Note that each access time has a specific operating voltage range (V_{CC}) as specified in the [Product Selector Guide](#) and the [Ordering Information](#) sections. The device is offered in an 80-ball Fortified BGA package. Each device has separate chip enable (CE#), write enable (WE#) and output enable (OE#) controls.

Each device requires only a **single 3.0 volt power supply** for both read and write functions. In addition to a V_{CC} input, a high-voltage **accelerated program (WP#/ACC)** input provides shorter programming times through increased current. This feature is intended to facilitate factory throughput during system production, but may also be used in the field if desired.

The device is entirely command set compatible with the **JEDEC single-power-supply Flash standard**. Commands are written to the device using standard microprocessor write timing. Write cycles also internally latch addresses and data needed for the programming and erase operations.

The **sector erase architecture** allows memory sectors to be erased and reprogrammed without affecting the data contents of other sectors. The device is fully erased when shipped from the factory.

Device programming and erasure are initiated through command sequences. Once a program or erase operation has begun, the host system need only poll the DQ7 and DQ15 (Data# Polling) or DQ6 and DQ14 (toggle) **status bits** or monitor the **Ready/Busy# (RY/BY#)** outputs to determine whether the operation is complete. To facilitate programming, an **Unlock Bypass** mode reduces command sequence overhead by requiring only two write cycles to program data instead of four.

The **VersatileI/O™** (V_{IO}) control allows the host system to set the voltage levels that the device generates

RELATED DOCUMENTS

For a comprehensive information on MirrorBit products, including migration information, data sheets, application notes, and software drivers, please see www.amd.com→[Flash Memory](#)→[Product Information](#)→[MirrorBit](#)→[Flash Information](#)→[Technical Documentation](#). The following is a partial list of documents closely related to this product:

and tolerates on the CE# control input and DQ I/Os to the same voltage level that is asserted on the V_{IO} pin. Refer to the Ordering Information section for valid V_{IO} options.

Hardware data protection measures include a low V_{CC} detector that automatically inhibits write operations during power transitions. The hardware sector protection feature disables both program and erase operations in any combination of sectors of memory. This can be achieved in-system or via programming equipment.

The **Erase Suspend/Erase Resume** feature allows the host system to pause an erase operation in a given sector to read or program any other sector and then complete the erase operation. The **Program Suspend/Program Resume** feature enables the host system to pause a program operation in a given sector to read any other sector and then complete the program operation.

The **hardware RESET# pin** terminates any operation in progress and resets the device, after which it is then ready for a new operation. The RESET# pin may be tied to the system reset circuitry. A system reset would thus also reset the device, enabling the host system to read boot-up firmware from the Flash memory device.

The device reduces power consumption in the **standby mode** when it detects specific voltage levels on CE# and RESET#, or when addresses have been stable for a specified period of time.

The **SecSi™ (Secured Silicon) Sector** provides a 128-doubleword/256-word area for code or data that can be permanently protected. Once this sector is protected, no further changes within the sector can occur.

The **Write Protect (WP#/ACC)** feature protects the first or last sector by asserting a logic low on the WP# pin.

AMD MirrorBit™ flash technology combines years of Flash memory manufacturing experience to produce the highest levels of quality, reliability and cost effectiveness. The device electrically erases all bits within a sector simultaneously via hot-hole assisted erase. The data is programmed using hot electron injection.

MirrorBit™ Flash Memory Write Buffer Programming and Page Buffer Read

Implementing a Common Layout for AMD MirrorBit and Intel StrataFlash Memory Devices

Migrating from Single-byte to Three-byte Device IDs

TABLE OF CONTENTS

Product Selector Guide	4	Chip Erase Command Sequence	29
MCP Block Diagram	4	Sector Erase Command Sequence	29
Flash Memory Block diagram	5	Erase Suspend/Erase Resume Commands	30
Connection Diagrams	6	Figure 7. Erase Operation	31
Special Package Handling Instructions	6	Table 10. Command Definitions (x32 Mode, WORD# = V _{IH})	32
Pin Configuration	7	Table 11. Command Definitions (x16 Mode, WORD# = V _{IL})	33
Logic Symbols	7	Write Operation Status	34
x16 Mode	7	DQ7 and DQ5: Data# Polling	34
x32 Mode	7	Figure 8. Data# Polling Algorithm	34
Ordering Information	8	DQ6 and DQ14: Toggle Bits I	35
Device Bus Operations	9	Figure 9. Toggle Bit Algorithm	36
Table 1. Device Bus Operations	9	DQ2 and DQ10: Toggle Bits II	36
VersatileIO™ (V _{IO}) Control	9	Reading Toggle Bits DQ6 and DQ14/DQ2 and DQ10	36
Requirements for Reading Array Data	10	DQ5 and DQ13: Exceeded Timing Limits	37
Page Mode Read	10	DQ3 and DQ11: Sector Erase Timer	37
Writing Commands/Command Sequences	10	DQ1: Write-to-Buffer Abort	38
Write Buffer	10	Table 12. Write Operation Status	38
Accelerated Program Operation	10	Absolute Maximum Ratings	39
Autoselect Functions	10	Figure 10. Maximum Negative Overshoot Waveform	39
Automatic Sleep Mode	11	Figure 11. Maximum Positive Overshoot Waveform	39
RESET#: Hardware Reset Pin	11	Operating Ranges	39
Output Disable Mode	11	DC Characteristics	40
Table 2. Sector Address Table	12	Test Conditions	41
Table 3. Autoselect Codes, (High Voltage Method)	15	Figure 12. Test Setup	41
Sector Group Protection and Unprotection	16	Table 13. Test Specifications	41
Table 4. Sector Group Protection/Unprotection Address Table	16	Key to Switching Waveforms	41
Temporary Sector Group Unprotect	17	Figure 13. Input Waveforms and	
Figure 1. Temporary Sector Group Unprotect Operation	17	Measurement Levels	41
Figure 2. In-System Sector Group Protect/Unprotect Algorithms	18	AC Characteristics	42
SecSi (Secured Silicon) Sector Flash Memory Region	19	Read-Only Operations	42
Table 5. SecSi Sector Contents	19	Figure 14. Read Operation Timings	42
Figure 3. SecSi Sector Protect Verify	20	Figure 15. Page Read Timings	43
Hardware Data Protection	20	Hardware Reset (RESET#)	44
Low VCC Write Inhibit	20	Figure 16. Reset Timings	44
Write Pulse “Glitch” Protection	20	Erase and Program Operations	45
Logical Inhibit	20	Figure 17. Program Operation Timings	46
Power-Up Write Inhibit	20	Figure 18. Accelerated Program Timing Diagram	46
Common Flash Memory Interface (CFI)	20	Figure 19. Chip/Sector Erase Operation Timings	47
Table 6. CFI Query Identification String	21	Figure 20. Data# Polling Timings (During Embedded Algorithms)	48
Table 7. System Interface String	21	Figure 21. Toggle Bit Timings (During Embedded Algorithms)	49
Table 8. Device Geometry Definition	22	Figure 22. DQ2 vs. DQ6	49
Table 9. Primary Vendor-Specific Extended Query	23	Temporary Sector Unprotect	50
Command Definitions	24	Figure 23. Temporary Sector Group Unprotect Timing Diagram	50
Reading Array Data	24	Figure 24. Sector Group Protect and Unprotect Timing Diagram	51
Reset Command	24	Alternate CE# Controlled Erase and Program Operations	52
Autoselect Command Sequence	24	Figure 25. Alternate CE# Controlled Write (Erase/Program)	
Enter SecSi Sector/Exit SecSi Sector Command Sequence	25	Operation Timings	53
Doubleword/Word Program Command Sequence	25	Latchup Characteristics	53
Unlock Bypass Command Sequence	25	Erase And Programming Performance	54
Write Buffer Programming	25	TSOP Pin and BGA Package Capacitance	54
Accelerated Program	26	Data Retention	54
Figure 4. Write Buffer Programming Operation	27	LSB080—80-Ball Fortified Ball Grid Array (Fortified BGA)	
Figure 5. Program Operation	28	13 x 11 mm Package	55
Program Suspend/Program Resume Command Sequence	28	Revision Summary	56
Figure 6. Program Suspend/Program Resume	29		

PRODUCT SELECTOR GUIDE

Part Number		Am29LV1282M	
Speed Option	$V_{CC} = 3.0-3.6 V$	100R ($V_{IO} = 2.7-3.6 V$)	110R ($V_{IO} = 1.65-3.6 V$)
Max. Access Time (ns)		100	110
Max. CE# Access Time (ns)		100	110
Max. Page access time (t_{PACC})		30	30
Max. OE# Access Time (ns)		30	30

MCP BLOCK DIAGRAM

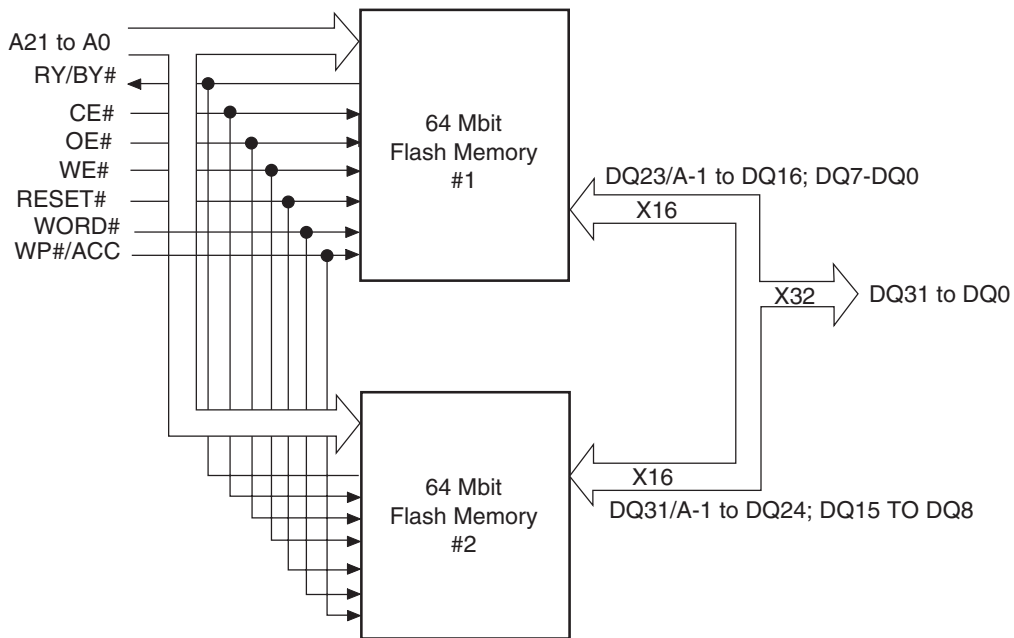

Note: In x16 Mode, DQ31 and DQ23 must be connected together on the board.

FLASH MEMORY BLOCK DIAGRAM

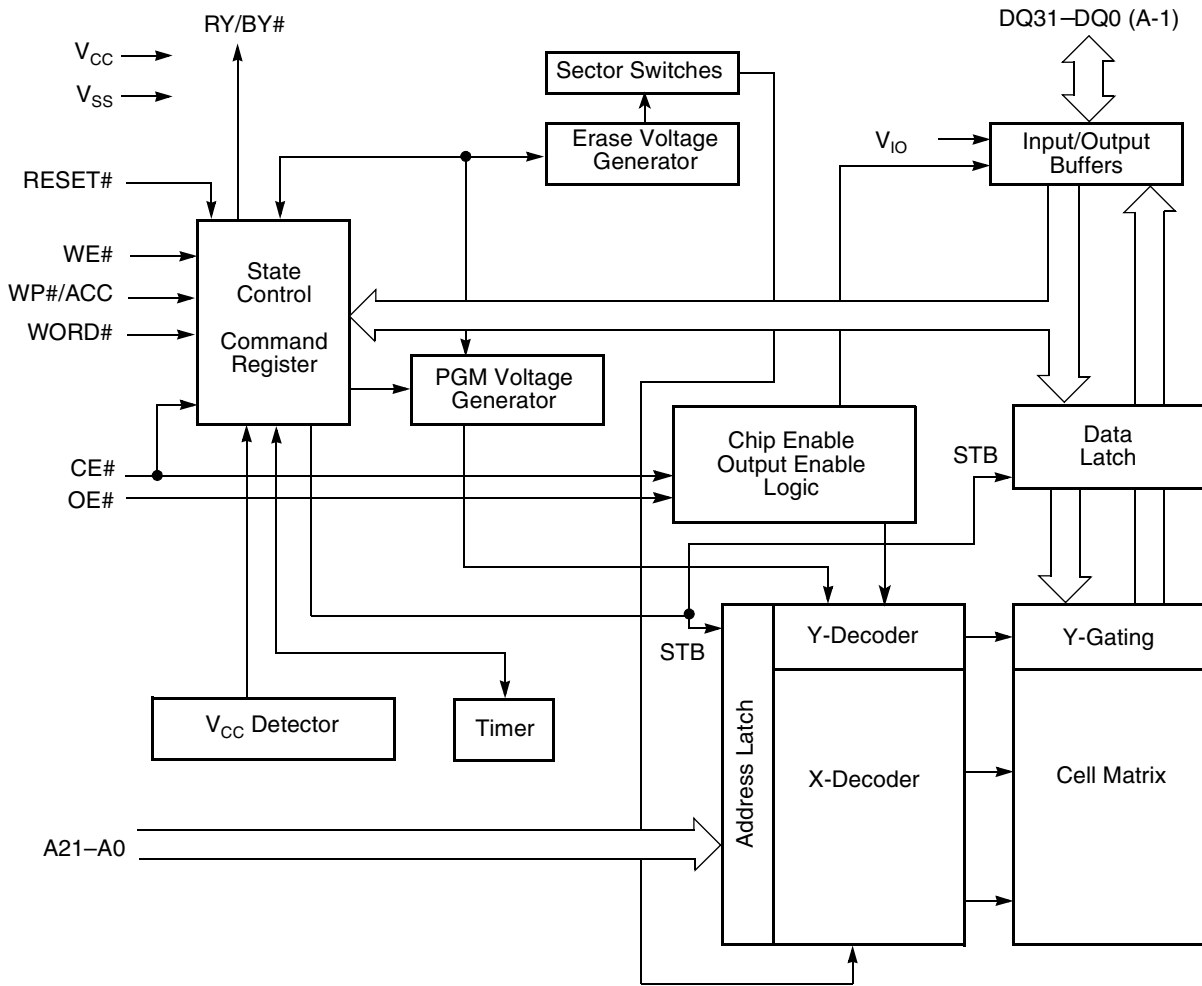

Note: In x16 Mode, DQ31 and DQ23 must be connected together on the board.

CONNECTION DIAGRAMS

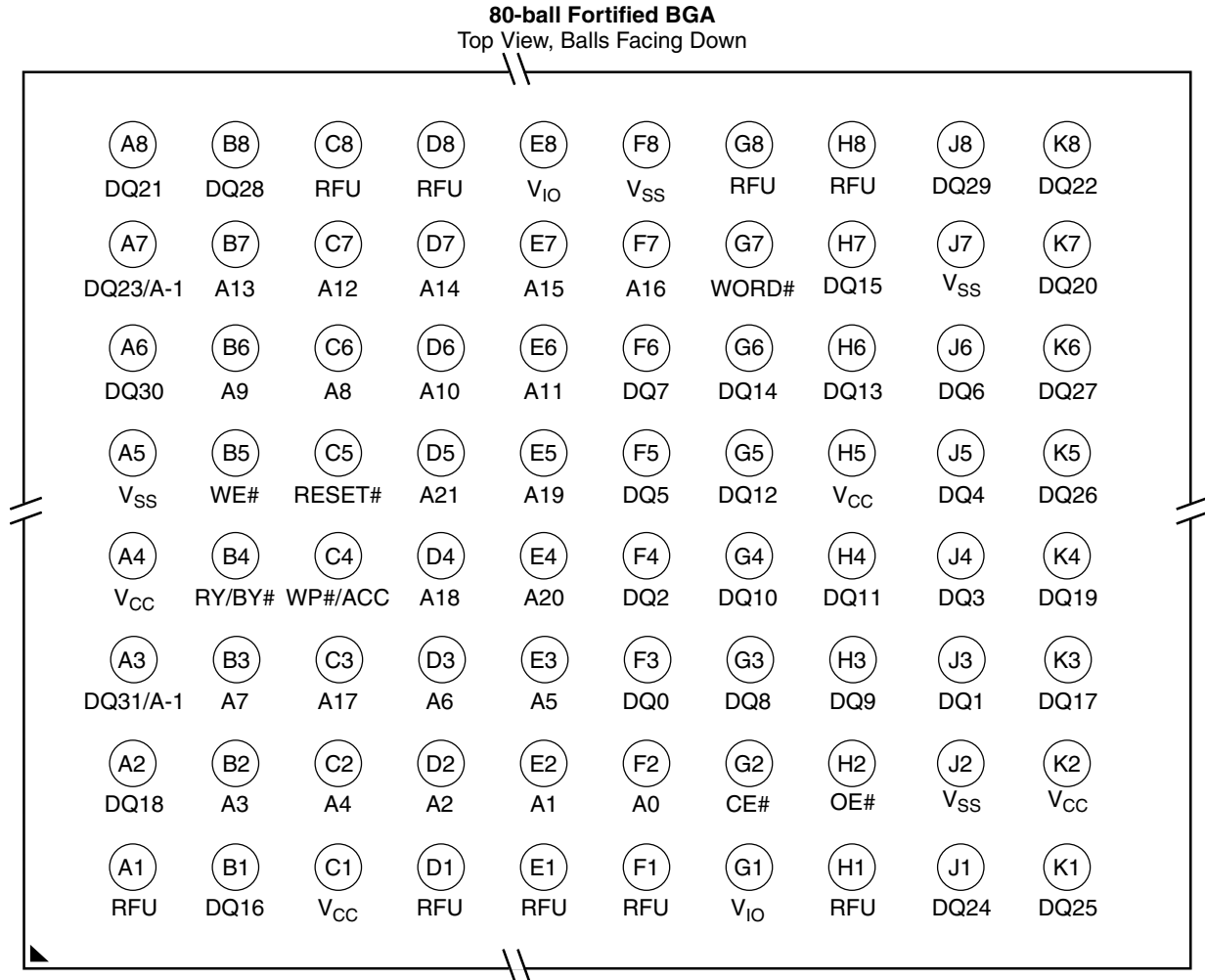

Note: The FBGA package pinout configuration shown is preliminary. The ball count and package physical dimensions have not yet been determined. Contact AMD for further information.

Special Package Handling Instructions

Special handling is required for Flash Memory products in molded packages (TSOP, BGA, PLCC, PDIP, SSOP). The package and/or data integrity may be

compromised if the package body is exposed to temperatures above 150°C for prolonged periods of time.

PIN CONFIGURATION

A-1	= Least significant address bit for the 16-bit data bus, and selects between the high and low word. A -1 is not used for the 32-bit mode (WORD# = V _{IH}).	V _{SS}	= Device ground
A21-A0	= 22-bit address bus for 128 Mb device.	RY/BY#	= Ready/Busy output and open drain. When RY/BY# = V _{OH} , the device is ready to accept read operations and commands. When RY/BY# = V _{OL} , the device is either executing an embedded algorithm or the device is executing a hardware reset operation.
DQ31-DQ0	= 32-bit data inputs/outputs/float	WP#/ACC	= Write Protect input/Acceleration input.
WORD#	= Selects 16-bit or 32-bit mode. When WORD# = V _{IH} , data is output on DQ31-DQ0. When WORD# = V _{IL} , data is output on DQ15-DQ0.	V _{CC}	= Power Supply (2.7 V to 3.6 V)
CE#	= Chip Enable Input.	RESET#	= Hardware reset input
OE#	= Output Enable Input.	NC	= Pin not connected internally
WE#	= Write enable.		

LOGIC SYMBOLS

x16 Mode

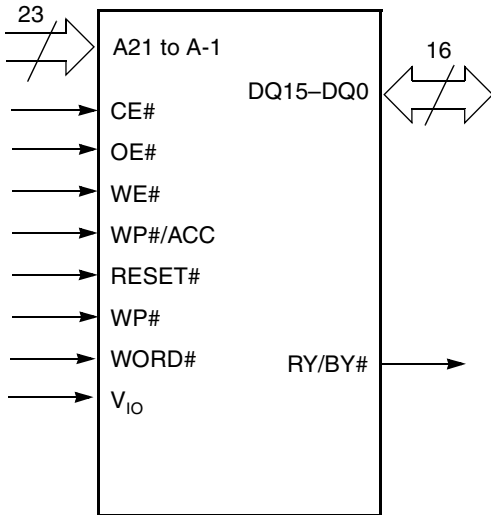

x32 Mode

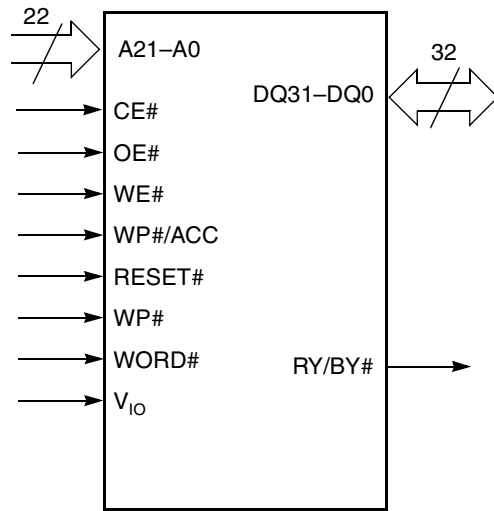

Note: In x16 mode, DQ31 and DQ23 must be connected to each other on the board.

ORDERING INFORMATION

Standard Products

AMD standard products are available in several packages and operating ranges. The order number (Valid Combination) is formed by a combination of the following:

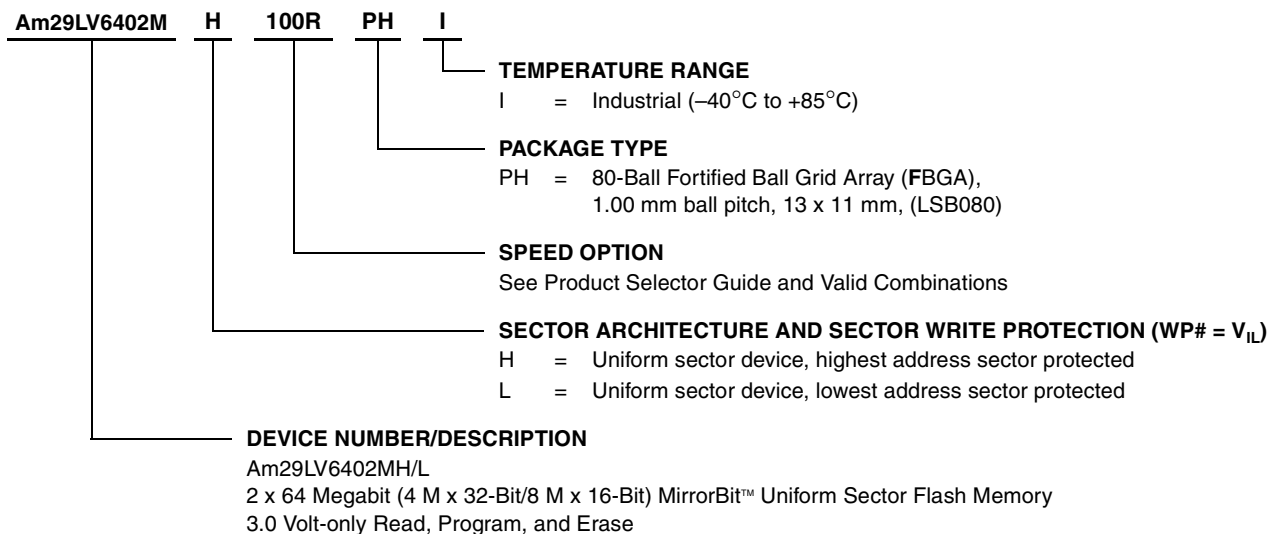

Valid Combinations

Valid Combinations list configurations planned to be supported in volume for this device. Consult the local AMD sales office to confirm availability of specific valid combinations and to check on newly released combinations.

Valid Combinations for Fortified BGA Package			Speed (ns)	V _{CC} Range	V _{IO} Range
Order Number	Package Marking				
Am29LV6402MH100R, Am29LV6402ML100R	PHI L6402MH10R	I	100	3.0– 3.6 V	2.7– 3.6 V
Am29LV6402MH110R, Am29LV6402ML110R	PHI L6402ML11R	I	110		1.65– 3.6 V

DEVICE BUS OPERATIONS

This section describes the requirements and use of the device bus operations, which are initiated through the internal command register. The command register itself does not occupy any addressable memory location. The register is a latch used to store the commands, along with the address and data information needed to execute the command. The contents of the

register serve as inputs to the internal state machine. The state machine outputs dictate the function of the device. Table 1 lists the device bus operations, the inputs and control levels they require, and the resulting output. The following subsections describe each of these operations in further detail.

Table 1. Device Bus Operations

Operation	CE#	OE#	WE#	RESET#	WP#	ACC	Addresses (Note 2)	DQ15– DQ0	DQ31–DQ16	
									WORD# = V _{IH}	WORD# = V _{IL}
Read	L	L	H	H	X	X	A _{IN}	D _{OUT}	D _{OUT}	DQ31–DQ16 = High-Z, DQ31 & DQ23= A-1
Write (Program/Erase)	L	H	L	H	(Note 3)	X	A _{IN}	(Note 4)	(Note 4)	
Accelerated Program	L	H	L	H	(Note 3)	V _{HH}	A _{IN}	(Note 4)	(Note 4)	
Standby	V _{CC} ± 0.3 V	X	X	V _{CC} ± 0.3 V	X	H	X	High-Z	High-Z	High-Z
Output Disable	L	H	H	H	X	X	X	High-Z	High-Z	High-Z
Reset	X	X	X	L	X	X	X	High-Z	High-Z	High-Z
Sector Group Protect (Note 2)	L	H	L	V _{ID}	H	X	SA, A6=L, A3=L, A2=L, A1=H, A0=L	(Note 4)	X	X
Sector Group Unprotect (Note 2)	L	H	L	V _{ID}	H	X	SA, A6=H, A3=L, A2=L, A1=H, A0=L	(Note 4)	X	X
Temporary Sector Group Unprotect	X	X	X	V _{ID}	H	X	A _{IN}	(Note 4)	(Note 4)	High-Z

Legend: L = Logic Low = V_{IL}, H = Logic High = V_{IH}, V_{ID} = 11.5–12.5 V, V_{HH} = 11.5–12.5V, X = Don't Care, SA = Sector Address, A_{IN} = Address In, D_{IN} = Data In, D_{OUT} = Data Out

Notes:

- Addresses are A21:A0 in doubleword mode; A21:A-1 in word mode. Sector addresses are A21:A15 in both modes.
- The sector protect and sector unprotect functions may also be implemented via programming equipment. See the "Sector Group Protection and Unprotection" section.
- If WP# = V_{IL}, the first or last sector remains protected. If WP# = V_{IH}, the first or last sector will be protected or unprotected as determined by the method described in "Sector Group Protection and Unprotection". All sectors are unprotected when shipped from the factory (The SecSi Sector may be factory protected depending on version ordered.)
- D_{IN} or D_{OUT} as required by command sequence, data polling, or sector protect algorithm (see Figure 2).

Word/Byte Configuration

The WORD# pin controls whether the device data I/O pins operate in the word or doubleword configuration. If the WORD# pin is set at V_{IH}, the device is in doubleword configuration, DQ31–DQ0 are active and controlled by CE# and OE#.

If the WORD# pin is set at V_{IL}, the device is in word configuration, and only data I/O pins DQ15–DQ0 are active and controlled by CE# and OE#. The data I/O pins DQ31–DQ16 are tri-stated, and the DQ23 and

DQ31 pins are used as inputs for the LSB (A-1) address function.

VersatileIO™ (V_{IO}) Control

The VersatileIO™ (V_{IO}) control allows the host system to set the voltage levels that the device generates and tolerates on CE# and DQ I/Os to the same voltage level that is asserted on V_{IO}. See Ordering Information for V_{IO} options on this device.

Requirements for Reading Array Data

To read array data from the outputs, the system must drive the CE# and OE# pins to V_{IL} . CE# is the power control and selects the device. OE# is the output control and gates array data to the output pins. WE# should remain at V_{IH} .

The internal state machine is set for reading array data upon device power-up, or after a hardware reset. This ensures that no spurious alteration of the memory content occurs during the power transition. No command is necessary in this mode to obtain array data. Standard microprocessor read cycles that assert valid addresses on the device address inputs produce valid data on the device data outputs. The device remains enabled for read access until the command register contents are altered.

See “Reading Array Data” for more information. Refer to the AC Read-Only Operations table for timing specifications and to Figure 14 for the timing diagram. Refer to the DC Characteristics table for the active current specification on reading array data.

Page Mode Read

The device is capable of fast page mode read and is compatible with the page mode Mask ROM read operation. This mode provides faster read access speed for random locations within a page. The page size of the device is 4 doublewords/8 words. The appropriate page is selected by the higher address bits A(max)–A2. Address bits A1–A0 in doubleword mode (A1–A-1 in word mode) determine the specific word within a page. This is an asynchronous operation; the microprocessor supplies the specific word location.

The random or initial page access is equal to t_{ACC} or t_{CE} and subsequent page read accesses (as long as the locations specified by the microprocessor falls within that page) is equivalent to t_{PACC} . When CE# is deasserted and reasserted for a subsequent access, the access time is t_{ACC} or t_{CE} . Fast page mode accesses are obtained by keeping the “read-page addresses” constant and changing the “intra-read page” addresses.

Writing Commands/Command Sequences

To write a command or command sequence (which includes programming data to the device and erasing sectors of memory), the system must drive WE# and CE# to V_{IL} , and OE# to V_{IH} .

The device features an **Unlock Bypass** mode to facilitate faster programming. Once the device enters the Unlock Bypass mode, only two write cycles are required to program a word or byte, instead of four. The “Doubleword/Word Program Command Sequence” section has details on programming data to the device

using both standard and Unlock Bypass command sequences.

An erase operation can erase one sector, multiple sectors, or the entire device. Table 2 indicates the address space that each sector occupies.

Refer to the DC Characteristics table for the active current specification for the write mode. The AC Characteristics section contains timing specification tables and timing diagrams for write operations.

Write Buffer

Write Buffer Programming allows the system write to a maximum of 16 doublewords/32 words in one programming operation. This results in faster effective programming time than the standard programming algorithms. See “Write Buffer” for more information.

Accelerated Program Operation

The device offers accelerated program operations through the ACC function. This is one of two functions provided by the WP#/ACC pin. This function is primarily intended to allow faster manufacturing throughput at the factory.

If the system asserts V_{HH} on this pin, the device automatically enters the aforementioned Unlock Bypass mode, temporarily unprotects any protected sectors, and uses the higher voltage on the pin to reduce the time required for program operations. The system would use a two-cycle program command sequence as required by the Unlock Bypass mode. Removing V_{HH} from the WP#/ACC pin returns the device to normal operation. *Note that the WP#/ACC pin must not be at V_{HH} for operations other than accelerated programming, or device damage may result. WP# has an internal pullup; when unconnected, WP# is at V_{IH} .*

Autoselect Functions

If the system writes the autoselect command sequence, the device enters the autoselect mode. The system can then read autoselect codes from the internal register (which is separate from the memory array) on DQ7–DQ0. Standard read cycle timings apply in this mode. Refer to the Autoselect Mode and Autoselect Command Sequence sections for more information.

Standby Mode

When the system is not reading or writing to the device, it can place the device in the standby mode. In this mode, current consumption is greatly reduced, and the outputs are placed in the high impedance state, independent of the OE# input.

The device enters the CMOS standby mode when the CE# and RESET# pins are both held at $V_{CC} \pm 0.3 V$. (Note that this is a more restricted voltage range than

V_{IH} .) If CE# and RESET# are held at V_{IH} , but not within $V_{CC} \pm 0.3$ V, the device will be in the standby mode, but the standby current will be greater. The device requires standard access time (t_{CE}) for read access when the device is in either of these standby modes, before it is ready to read data.

If the device is deselected during erasure or programming, the device draws active current until the operation is completed.

Refer to the DC Characteristics table for the standby current specification.

Automatic Sleep Mode

The automatic sleep mode minimizes Flash device energy consumption. The device automatically enables this mode when addresses remain stable for $t_{ACC} + 30$ ns. The automatic sleep mode is independent of the CE#, WE#, and OE# control signals. Standard address access timings provide new data when addresses are changed. While in sleep mode, output data is latched and always available to the system. Refer to the DC Characteristics table for the automatic sleep mode current specification.

RESET#: Hardware Reset Pin

The RESET# pin provides a hardware method of resetting the device to reading array data. When the RE-

SET# pin is driven low for at least a period of t_{RP} , the device immediately terminates any operation in progress, tristates all output pins, and ignores all read/write commands for the duration of the RESET# pulse. The device also resets the internal state machine to reading array data. The operation that was interrupted should be reinitiated once the device is ready to accept another command sequence, to ensure data integrity.

Current is reduced for the duration of the RESET# pulse. When RESET# is held at $V_{SS} \pm 0.3$ V, the device draws CMOS standby current (I_{CC4}). If RESET# is held at V_{IL} but not within $V_{SS} \pm 0.3$ V, the standby current will be greater.

The RESET# pin may be tied to the system reset circuitry. A system reset would thus also reset the Flash memory, enabling the system to read the boot-up firmware from the Flash memory.

Refer to the AC Characteristics tables for RESET# parameters and to Figure 16 for the timing diagram.

Output Disable Mode

When the OE# input is at V_{IH} , output from the device is disabled. The output pins are placed in the high impedance state.

Table 2. Sector Address Table

Sector	A21-A15							Sector Size (Kwords/Kdoublewords)	16-bit Address Range (in hexadecimal)	32-bit Address Range (in hexadecimal)
SA0	0	0	0	0	0	0	0	64/32	000000-00FFFF	000000-007FFF
SA1	0	0	0	0	0	0	1	64/32	010000-01FFFF	008000-00FFFF
SA2	0	0	0	0	0	1	0	64/32	020000-02FFFF	010000-017FFF
SA3	0	0	0	0	0	1	1	64/32	030000-03FFFF	018000-01FFFF
SA4	0	0	0	0	1	0	0	64/32	040000-04FFFF	020000-027FFF
SA5	0	0	0	0	1	0	1	64/32	050000-05FFFF	028000-02FFFF
SA6	0	0	0	0	1	1	0	64/32	060000-06FFFF	030000-037FFF
SA7	0	0	0	0	1	1	1	64/32	070000-07FFFF	038000-03FFFF
SA8	0	0	0	1	0	0	0	64/32	080000-08FFFF	040000-047FFF
SA9	0	0	0	1	0	0	1	64/32	090000-09FFFF	048000-04FFFF
SA10	0	0	0	1	0	1	0	64/32	0A0000-0AFFFF	050000-057FFF
SA11	0	0	0	1	0	1	1	64/32	0B0000-0BFFFF	058000-05FFFF
SA12	0	0	0	1	1	0	0	64/32	0C0000-0CFFFF	060000-067FFF
SA13	0	0	0	1	1	0	1	64/32	0D0000-0DFFFF	068000-06FFFF
SA14	0	0	0	1	1	1	0	64/32	0E0000-0EFFFF	070000-077FFF
SA15	0	0	0	1	1	1	1	64/32	0F0000-0FFFFF	078000-07FFFF
SA16	0	0	1	0	0	0	0	64/32	100000-10FFFF	080000-087FFF
SA17	0	0	1	0	0	0	1	64/32	110000-11FFFF	088000-08FFFF
SA18	0	0	1	0	0	1	0	64/32	120000-12FFFF	090000-097FFF
SA19	0	0	1	0	0	1	1	64/32	130000-13FFFF	098000-09FFFF
SA20	0	0	1	0	1	0	0	64/32	140000-14FFFF	0A0000-0A7FFF
SA21	0	0	1	0	1	0	1	64/32	150000-15FFFF	0A8000-0AFFFF
SA22	0	0	1	0	1	1	0	64/32	160000-16FFFF	0B0000-0B7FFF
SA23	0	0	1	0	1	1	1	64/32	170000-17FFFF	0B8000-0BFFFF
SA24	0	0	1	1	0	0	0	64/32	180000-18FFFF	0C0000-0C7FFF
SA25	0	0	1	1	0	0	1	64/32	190000-19FFFF	0C8000-0CFFFF
SA26	0	0	1	1	0	1	0	64/32	1A0000-1AFFFF	0D0000-0D7FFF
SA27	0	0	1	1	0	1	1	64/32	1B0000-1BFFFF	0D8000-0DFFFF
SA28	0	0	1	1	1	0	0	64/32	1C0000-1CFFFF	0E0000-0E7FFF
SA29	0	0	1	1	1	0	1	64/32	1D0000-1DFFFF	0E8000-0EFFFF
SA30	0	0	1	1	1	1	0	64/32	1E0000-1EFFFF	0F0000-0F7FFF
SA31	0	0	1	1	1	1	1	64/32	1F0000-1FFFFF	0F8000-0FFFFF
SA32	0	1	0	0	0	0	0	64/32	0200000-20FFFF	100000-107FFF
SA33	0	1	0	0	0	0	1	64/32	210000-21FFFF	108000-10FFFF
SA34	0	1	0	0	0	1	0	64/32	220000-22FFFF	110000-117FFF
SA35	0	1	0	0	0	1	1	64/32	230000-23FFFF	118000-11FFFF
SA36	0	1	0	0	1	0	0	64/32	240000-24FFFF	120000-127FFF
SA37	0	1	0	0	1	0	1	64/32	250000-25FFFF	128000-12FFFF
SA38	0	1	0	0	1	1	0	64/32	260000-26FFFF	130000-137FFF
SA39	0	1	0	0	1	1	1	64/32	270000-27FFFF	138000-13FFFF
SA40	0	1	0	1	0	0	0	64/32	280000-28FFFF	140000-147FFF
SA41	0	1	0	1	0	0	1	64/32	290000-29FFFF	148000-14FFFF
SA42	0	1	0	1	0	1	0	64/32	2A0000-2AFFFF	150000-157FFF
SA43	0	1	0	1	0	1	1	64/32	2B0000-2BFFFF	158000-15FFFF
SA44	0	1	0	1	1	0	0	64/32	2C0000-2CFFFF	160000-167FFF
SA45	0	1	0	1	1	0	1	64/32	2D0000-2DFFFF	168000-16FFFF
SA46	0	1	0	1	1	1	0	64/32	2E0000-2EFFFF	170000-177FFF

Table 2. Sector Address Table (Continued)

Sector	A21–A15							Sector Size (Kwords/Kdoublewords)	16-bit Address Range (in hexadecimal)	32-bit Address Range (in hexadecimal)
	0	1	0	1	1	1	1			
SA47	0	1	0	1	1	1	1	64/32	2F0000–2FFFFFF	178000–17FFFF
SA48	0	1	1	0	0	0	0	64/32	300000–30FFFF	180000–187FFF
SA49	0	1	1	0	0	0	1	64/32	310000–31FFFF	188000–18FFFF
SA50	0	1	1	0	0	1	0	64/32	320000–32FFFF	190000–197FFF
SA51	0	1	1	0	0	1	1	64/32	330000–33FFFF	198000–19FFFF
SA52	0	1	1	0	1	0	0	64/32	340000–34FFFF	1A0000–1A7FFF
SA53	0	1	1	0	1	0	1	64/32	350000–35FFFF	1A8000–1AFFFF
SA54	0	1	1	0	1	1	0	64/32	360000–36FFFF	1B0000–1B7FFF
SA55	0	1	1	0	1	1	1	64/32	370000–37FFFF	1B8000–1BFFFF
SA56	0	1	1	1	0	0	0	64/32	380000–38FFFF	1C0000–1C7FFF
SA57	0	1	1	1	0	0	1	64/32	390000–39FFFF	1C8000–1CFFFF
SA58	0	1	1	1	0	1	0	64/32	3A0000–3AFFFF	1D0000–1D7FFF
SA59	0	1	1	1	0	1	1	64/32	3B0000–3BFFFF	1D8000–1DFFFF
SA60	0	1	1	1	1	0	0	64/32	3C0000–3CFFFF	1E0000–1E7FFF
SA61	0	1	1	1	1	0	1	64/32	3D0000–3DFFFF	1E8000–1EFFFF
SA62	0	1	1	1	1	1	0	64/32	3E0000–3EFFFF	1F0000–1F7FFF
SA63	0	1	1	1	1	1	1	64/32	3F0000–3FFFFFF	1F8000–1FFFFFF
SA64	1	0	0	0	0	0	0	64/32	400000–40FFFF	200000–207FFF
SA65	1	0	0	0	0	0	1	64/32	410000–41FFFF	208000–20FFFF
SA66	1	0	0	0	0	1	0	64/32	420000–42FFFF	210000–217FFF
SA67	1	0	0	0	0	1	1	64/32	430000–43FFFF	218000–21FFFF
SA68	1	0	0	0	1	0	0	64/32	440000–44FFFF	220000–227FFF
SA69	1	0	0	0	1	0	1	64/32	450000–45FFFF	228000–22FFFF
SA70	1	0	0	0	1	1	0	64/32	460000–46FFFF	230000–237FFF
SA71	1	0	0	0	1	1	1	64/32	470000–47FFFF	238000–23FFFF
SA72	1	0	0	1	0	0	0	64/32	480000–48FFFF	240000–247FFF
SA73	1	0	0	1	0	0	1	64/32	490000–49FFFF	248000–24FFFF
SA74	1	0	0	1	0	1	0	64/32	4A0000–4AFFFF	250000–257FFF
SA75	1	0	0	1	0	1	1	64/32	4B0000–4BFFFF	258000–25FFFF
SA76	1	0	0	1	1	0	0	64/32	4C0000–4CFFFF	260000–267FFF
SA77	1	0	0	1	1	0	1	64/32	4D0000–4DFFFF	268000–26FFFF
SA78	1	0	0	1	1	1	0	64/32	4E0000–4EFFFF	270000–277FFF
SA79	1	0	0	1	1	1	1	64/32	4F0000–4FFFFFF	278000–27FFFF
SA80	1	0	1	0	0	0	0	64/32	500000–50FFFF	280000–287FFF
SA81	1	0	1	0	0	0	1	64/32	510000–51FFFF	288000–28FFFF
SA82	1	0	1	0	0	1	0	64/32	520000–52FFFF	290000–297FFF
SA83	1	0	1	0	0	1	1	64/32	530000–53FFFF	298000–29FFFF
SA84	1	0	1	0	1	0	0	64/32	540000–54FFFF	2A0000–2A7FFF
SA85	1	0	1	0	1	0	1	64/32	550000–55FFFF	2A8000–2AFFFF
SA86	1	0	1	0	1	1	0	64/32	560000–56FFFF	2B0000–2B7FFF
SA87	1	0	1	0	1	1	1	64/32	570000–57FFFF	2B8000–2BFFFF
SA88	1	0	1	1	0	0	0	64/32	580000–58FFFF	2C0000–2C7FFF
SA89	1	0	1	1	0	0	1	64/32	590000–59FFFF	2C8000–2CFFFF
SA90	1	0	1	1	0	1	0	64/32	5A0000–5AFFFF	2D0000–2D7FFF
SA91	1	0	1	1	0	1	1	64/32	5B0000–5BFFFF	2D8000–2DFFFF
SA92	1	0	1	1	1	0	0	64/32	5C0000–5CFFFF	2E0000–2E7FFF
SA93	1	0	1	1	1	0	1	64/32	5D0000–5DFFFF	2E8000–2EFFFF
SA94	1	0	1	1	1	1	0	64/32	5E0000–5EFFFF	2F0000–2F7FFF

Table 2. Sector Address Table (Continued)

Sector	A21–A15							Sector Size (Kwords/Kdoublewords)	16-bit Address Range (in hexadecimal)	32-bit Address Range (in hexadecimal)
SA95	1	0	1	1	1	1	1	64/32	5F0000–5FFFFFFF	2F8000–2FFFFFFF
SA96	1	1	0	0	0	0	0	64/32	600000–60FFFF	300000–307FFF
SA97	1	1	0	0	0	0	1	64/32	610000–61FFFF	308000–30FFFF
SA98	1	1	0	0	0	1	0	64/32	620000–62FFFF	310000–317FFF
SA99	1	1	0	0	0	1	1	64/32	630000–63FFFF	318000–31FFFF
SA100	1	1	0	0	1	0	0	64/32	640000–64FFFF	320000–327FFF
SA101	1	1	0	0	1	0	1	64/32	650000–65FFFF	328000–32FFFF
SA102	1	1	0	0	1	1	0	64/32	660000–66FFFF	330000–337FFF
SA103	1	1	0	0	1	1	1	64/32	670000–67FFFF	338000–33FFFF
SA104	1	1	0	1	0	0	0	64/32	680000–68FFFF	340000–347FFF
SA105	1	1	0	1	0	0	1	64/32	690000–69FFFF	348000–34FFFF
SA106	1	1	0	1	0	1	0	64/32	6A0000–6AFFFF	350000–357FFF
SA107	1	1	0	1	0	1	1	64/32	6B0000–6BFFFF	358000–35FFFF
SA108	1	1	0	1	1	0	0	64/32	6C0000–6CFFFF	360000–367FFF
SA109	1	1	0	1	1	0	1	64/32	6D0000–6DFFFF	368000–36FFFF
SA110	1	1	0	1	1	1	0	64/32	6E0000–6EFFFF	370000–377FFF
SA111	1	1	0	1	1	1	1	64/32	6F0000–6FFFFFFF	378000–37FFFF
SA112	1	1	1	0	0	0	0	64/32	700000–70FFFF	380000–387FFF
SA113	1	1	1	0	0	0	1	64/32	710000–71FFFF	388000–38FFFF
SA114	1	1	1	0	0	1	0	64/32	720000–72FFFF	390000–397FFF
SA115	1	1	1	0	0	1	1	64/32	730000–73FFFF	398000–39FFFF
SA116	1	1	1	0	1	0	0	64/32	740000–74FFFF	3A0000–3A7FFF
SA117	1	1	1	0	1	0	1	64/32	750000–75FFFF	3A8000–3AFFFF
SA118	1	1	1	0	1	1	0	64/32	760000–76FFFF	3B0000–3B7FFF
SA119	1	1	1	0	1	1	1	64/32	770000–77FFFF	3B8000–3BFFFF
SA120	1	1	1	1	0	0	0	64/32	780000–78FFFF	3C0000–3C7FFF
SA121	1	1	1	1	0	0	1	64/32	790000–79FFFF	3C8000–3CFFFF
SA122	1	1	1	1	0	1	0	64/32	7A0000–7AFFFF	3D0000–3D7FFF
SA123	1	1	1	1	0	1	1	64/32	7B0000–7BFFFF	3D8000–3DFFFF
SA124	1	1	1	1	1	0	0	64/32	7C0000–7CFFFF	3E0000–3E7FFF
SA125	1	1	1	1	1	0	1	64/32	7D0000–7DFFFF	3E8000–3EFFFF
SA126	1	1	1	1	1	1	0	64/32	7E0000–7EFFFF	3F0000–3F7FFF
SA127	1	1	1	1	1	1	1	64/32	7F0000–7FFFFFFF	3F8000–3FFFFFFF

Autoselect Mode

The autoselect mode provides manufacturer and device identification, and sector protection verification, through identifier codes output on DQ7–DQ0. This mode is primarily intended for programming equipment to automatically match a device to be programmed with its corresponding programming algorithm. However, the autoselect codes can also be accessed in-system through the command register.

When using programming equipment, the autoselect mode requires V_{ID} on address pin A9. Address pins A6, A3, A2, A1, and A0 must be as shown in Table 3.

In addition, when verifying sector protection, the sector address must appear on the appropriate highest order address bits (see Table 2). Table 3 shows the remaining address bits that are don't care. When all necessary bits have been set as required, the programming equipment may then read the corresponding identifier code on DQ7–DQ0.

To access the autoselect codes in-system, the host system can issue the autoselect command via the command register, as shown in Tables 10 and 11. This method does not require V_{ID} . Refer to the Autoselect Command Sequence section for more information.

Table 3. Autoselect Codes, (High Voltage Method)

Description	CE#	OE#	WE#	A21 to A15	A14 to A10	A9	A8 to A7	A6	A5 to A4	A3 to A2	A1	A0	DQ23 to DQ16		DQ7 to DQ0
													WORD# = V_{IH}	WORD# = V_{IL}	
Manufacturer ID: AMD	L	L	H	X	X	V_{ID}	X	L	X	L	L	L	00	X	01h
Device ID	L	L	H	X	X	V_{ID}	X	L	X	L	L	H	22	X	7Eh
										H	H	L	22	X	0Ch
										H	H	H	22	X	01h
Sector Protection Verification	L	L	H	SA	X	V_{ID}	X	L	X	L	H	L	X	X	01h (protected), 00h (unprotected)
SecSi Sector Indicator Bit (DQ7), WP# protects highest address sector	L	L	H	X	X	V_{ID}	X	L	X	L	H	H	X	X	98h (factory locked), 18h (not factory locked)
SecSi Sector Indicator Bit (DQ7), WP# protects lowest address sector	L	L	H	X	X	V_{ID}	X	L	X	L	H	H	X	X	88h (factory locked), 08h (not factory locked)

Legend: L = Logic Low = V_{IL} , H = Logic High = V_{IH} , SA = Sector Address, X = Don't care.

Sector Group Protection and Unprotection

The hardware sector group protection feature disables both program and erase operations in any sector group. In this device, a sector group consists of four adjacent sectors that are protected or unprotected at the same time (see Table 4). The hardware sector group unprotection feature re-enables both program and erase operations in previously protected sector groups. Sector group protection/unprotection can be implemented via two methods.

Sector protection/unprotection requires V_{ID} on the RE-SET# pin only, and can be implemented either in-system or via programming equipment. Figure 2 shows the algorithms and Figure 24 shows the timing diagram. This method uses standard microprocessor bus cycle timing. For sector group unprotect, all unprotected sector groups must first be protected prior to the first sector group unprotect write cycle.

The device is shipped with all sector groups unprotected. AMD offers the option of programming and protecting sector groups at its factory prior to shipping the device through AMD's ExpressFlash™ Service. Contact an AMD representative for details.

It is possible to determine whether a sector group is protected or unprotected. See the Autoselect Mode section for details.

Table 4. Sector Group Protection/Unprotection Address Table

Sector Group	A21–A15
SA0	0000000
SA1	0000001
SA2	0000010
SA3	0000011
SA4–SA7	00001xx
SA8–SA11	00010xx
SA12–SA15	00011xx
SA16–SA19	00100xx
SA20–SA23	00101xx
SA24–SA27	00110xx
SA28–SA31	00111xx
SA32–SA35	01000xx
SA36–SA39	01001xx
SA40–SA43	01010xx
SA44–SA47	01011xx
SA48–SA51	01100xx
SA52–SA55	01101xx
SA56–SA59	01110xx
SA60–SA63	01111xx
SA64–SA67	10000xx
SA68–SA71	10001xx
SA72–SA75	10010xx
SA76–SA79	10011xx
SA80–SA83	10100xx
SA84–SA87	10101xx
SA88–SA91	10110xx
SA92–SA95	10111xx
SA96–SA99	11000xx
SA100–SA103	11001xx
SA104–SA107	11010xx
SA108–SA111	11011xx
SA112–SA115	11100xx
SA116–SA119	11101xx
SA120–SA123	11110xx
SA124	1111100
SA125	1111101
SA126	1111110
SA127	1111111

Write Protect (WP#)

The Write Protect function provides a hardware method of protecting the first or last sector without using V_{ID} . Write Protect is one of two functions provided by the WP#/ACC input.

If the system asserts V_{IL} on the WP#/ACC pin, the device disables program and erase functions in the first or last sector independently of whether those sectors were protected or unprotected using the method described in “Sector Group Protection and Unprotection”. Note that if WP#/ACC is at V_{IL} when the device is in the standby mode, the maximum input load current is increased. See the table in “DC Characteristics”.

If the system asserts V_{IH} on the WP#/ACC pin, the device reverts to whether the first or last sector was previously set to be protected or unprotected using the method described in “Sector Group Protection and Unprotection”. *Note that WP# has an internal pullup; when unconnected, WP# is at V_{IH} .*

Temporary Sector Group Unprotect

Note: In this device, a sector group consists of four adjacent sectors that are protected or unprotected at the same time (see Figure 5). This feature allows temporary unprotection of previously protected sectors to change data in-system. The Sector Unprotect mode is activated by setting the RESET# pin to V_{ID} . During this mode, formerly protected sectors can be programmed or erased by selecting the sector addresses. Once V_{ID} is removed from the RESET# pin, all the previously protected sectors are protected again. Figure 1 shows the algorithm, and Figure 23 shows the timing diagrams, for this feature.

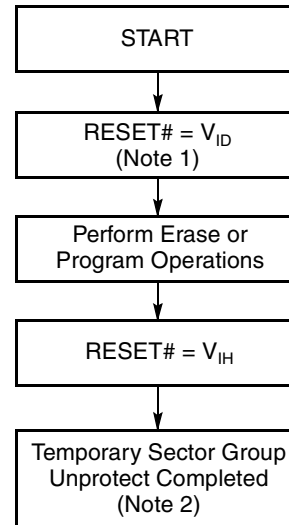

Notes:

1. All protected sector groups unprotected (If WP# = V_{IL} , the first or last sector will remain protected).
2. All previously protected sector groups are protected once again.

Figure 1. Temporary Sector Group Unprotect Operation

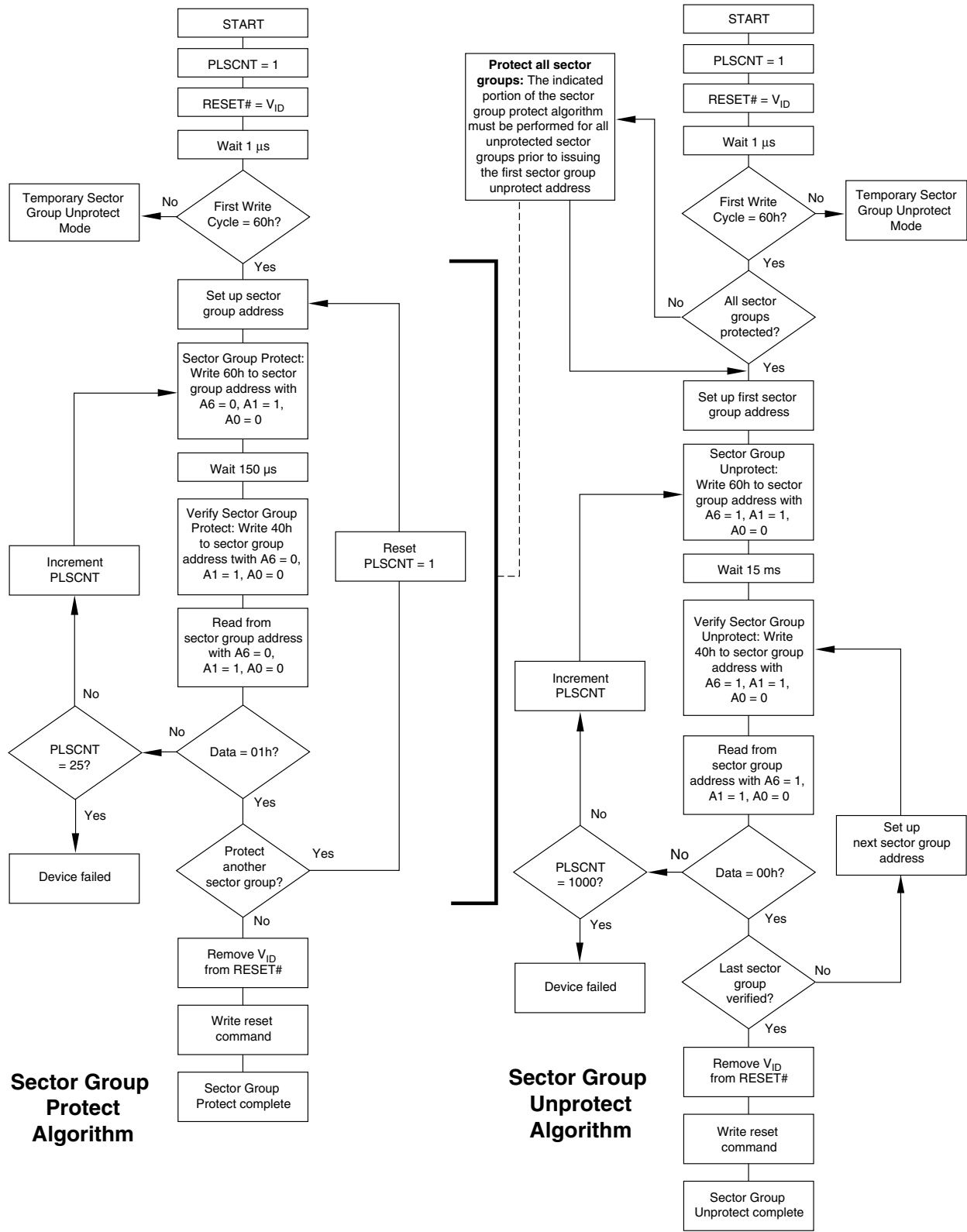

Figure 2. In-System Sector Group Protect/Unprotect Algorithms

SecSi (Secured Silicon) Sector Flash Memory Region

The SecSi (Secured Silicon) Sector feature provides a Flash memory region that enables permanent part identification through an Electronic Serial Number (ESN). The SecSi Sector is 128 doublewords/256 words in length, and uses SecSi Sector Indicator Bits (DQ7 and DQ15) to indicate whether or not the SecSi Sector is locked when shipped from the factory. These bits are permanently set at the factory and cannot be changed, which prevents cloning of a factory locked part. This ensures the security of the ESN once the product is shipped to the field.

AMD offers the device with the SecSi Sector either factory locked or customer lockable. The factory-locked version is always protected when shipped from the factory, and has the SecSi (Secured Silicon) Sector Indicator Bits permanently set to a “1.” The customer-lockable version is shipped with the SecSi Sector unprotected, allowing customers to program the sector after receiving the device. The customer-lockable version also has the SecSi Sector Indicator Bit permanently set to a “0.” Thus, the SecSi Sector Indicator Bits prevent customer-lockable devices from being used to replace devices that are factory locked.

The SecSi sector address space in this device is allocated as follows:

Table 5. SecSi Sector Contents

SecSi Sector Address Range		Standard Factory Locked	ExpressFlash Factory Locked	Customer Lockable
x32	x16			
000000h–000007h	000000h–00000Fh	ESN	ESN or determined by customer	Determined by customer
000008h–000007Fh	000010h–0000FFh	Unavailable	Determined by customer	

The system accesses the SecSi Sector through a command sequence (see “Enter SecSi Sector/Exit SecSi Sector Command Sequence”). After the system has written the Enter SecSi Sector command sequence, it may read the SecSi Sector by using the addresses normally occupied by the first sector (SA0). This mode of operation continues until the system issues the Exit SecSi Sector command sequence, or until power is removed from the device. On power-up, or following a hardware reset, the device reverts to sending commands to sector SA0.

Factory Locked: SecSi Sector Programmed and Protected At the Factory

In devices with an ESN, the SecSi Sector is protected when the device is shipped from the factory. The SecSi Sector cannot be modified in any way. A factory locked device has an 8-doubleword/16-word random ESN at addresses 000000h–000007h.

Customers may opt to have their code programmed by AMD through the AMD ExpressFlash service. The devices are then shipped from AMD’s factory with the SecSi Sector permanently locked. Contact an AMD representative for details on using AMD’s ExpressFlash service.

Customer Lockable: SecSi Sector NOT Programmed or Protected At the Factory

As an alternative to the factory-locked version, the device may be ordered such that the customer may program and protect the 128-doubleword/256 word SecSi sector.

The system may program the SecSi Sector using the write-buffer, accelerated and/or unlock bypass methods, in addition to the standard programming command sequence. See To reduce power consumption read Lower Byte only..

Programming and protecting the SecSi Sector must be used with caution since, once protected, there is no procedure available for unprotecting the SecSi Sector area and none of the bits in the SecSi Sector memory space can be modified in any way.

The SecSi Sector area can be protected using one of the following procedures:

- Write the three-cycle Enter SecSi Sector Region command sequence, and then follow the in-system sector protect algorithm as shown in Figure 2, except that *RESET# may be at either V_{IH} or V_{ID}*. This allows in-system protection of the SecSi Sector without raising any device pin to a high voltage. Note that this method is only applicable to the SecSi Sector.
- To verify the protect/unprotect status of the SecSi Sector, follow the algorithm shown in Figure 3.

Once the SecSi Sector is programmed, locked and verified, the system must write the Exit SecSi Sector Region command sequence to return to reading and writing within the remainder of the array.

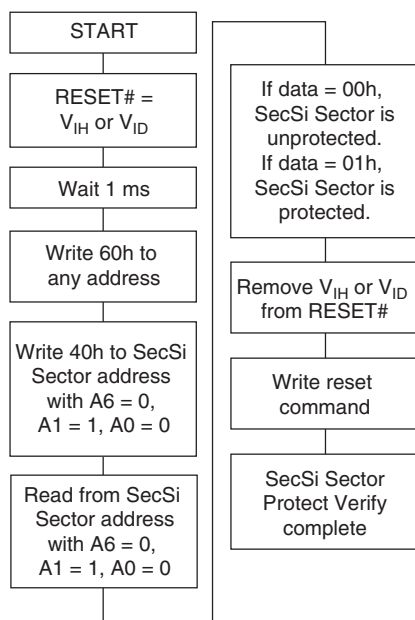

Figure 3. SecSi Sector Protect Verify

Hardware Data Protection

The command sequence requirement of unlock cycles for programming or erasing provides data protection against inadvertent writes (refer to Tables 10 and 11 for command definitions). In addition, the following hardware data protection measures prevent accidental erasure or programming, which might otherwise be

caused by spurious system level signals during V_{CC} power-up and power-down transitions, or from system noise.

Low V_{CC} Write Inhibit

When V_{CC} is less than V_{LKO} , the device does not accept any write cycles. This protects data during V_{CC} power-up and power-down. The command register and all internal program/erase circuits are disabled, and the device resets to the read mode. Subsequent writes are ignored until V_{CC} is greater than V_{LKO} . The system must provide the proper signals to the control pins to prevent unintentional writes when V_{CC} is greater than V_{LKO} .

Write Pulse “Glitch” Protection

Noise pulses of less than 5 ns (typical) on $OE\#$, $CE\#$ or $WE\#$ do not initiate a write cycle.

Logical Inhibit

Write cycles are inhibited by holding any one of $OE\# = V_{IL}$, $CE\# = V_{IH}$ or $WE\# = V_{IH}$. To initiate a write cycle, $CE\#$ and $WE\#$ must be a logical zero while $OE\#$ is a logical one.

Power-Up Write Inhibit

If $WE\# = CE\# = V_{IL}$ and $OE\# = V_{IH}$ during power up, the device does not accept commands on the rising edge of $WE\#$. The internal state machine is automatically reset to the read mode on power-up.

COMMON FLASH MEMORY INTERFACE (CFI)

The Common Flash Interface (CFI) specification outlines device and host system software interrogation handshake, which allows specific vendor-specified software algorithms to be used for entire families of devices. Software support can then be device-independent, JEDEC ID-independent, and forward- and backward-compatible for the specified flash device families. Flash vendors can standardize their existing interfaces for long-term compatibility.

This device enters the CFI Query mode when the system writes the CFI Query command, 98h, to address 55h, any time the device is ready to read array data. The system can read CFI information at the addresses

given in Tables 6–9. To terminate reading CFI data, the system must write the reset command.

The system can also write the CFI query command when the device is in the autoselect mode. The device enters the CFI query mode, and the system can read CFI data at the addresses given in Tables 6–9. The system must write the reset command to return the device to the autoselect mode.

For further information, please refer to the CFI Specification and CFI Publication 100, available via the World Wide Web at <http://www.amd.com/products/nvd/overview/cfi.html>. Alternatively, contact an AMD representative for copies of these documents.

Table 6. CFI Query Identification String

Addresses (x32)	Data	Description
10h 11h 12h	00005151h 00005252h 00005959h	Query Unique ASCII string "QRY"
13h 14h	00002020h 00000000h	Primary OEM Command Set
15h 16h	00004040h 00000000h	Address for Primary Extended Table
17h 18h	00000000h 00000000h	Alternate OEM Command Set (00h = none exists)
19h 1Ah	00000000h 00000000h	Address for Alternate OEM Extended Table (00h = none exists)

Table 7. System Interface String

Addresses (x16)	Data	Description
1Bh	00002727h	V _{CC} Min. (write/erase) D7–D4: volt, D3–D0: 100 millivolt
1Ch	00003636h	V _{CC} Max. (write/erase) D7–D4: volt, D3–D0: 100 millivolt
1Dh	00000000h	V _{PP} Min. voltage (00h = no V _{PP} pin present)
1Eh	00000000h	V _{PP} Max. voltage (00h = no V _{PP} pin present)
1Fh	00000707h	Typical timeout per single byte/word write 2 ^N μs
20h	00000707h	Typical timeout for Min. size buffer write 2 ^N μs (00h = not supported)
21h	00000A0Ah	Typical timeout per individual block erase 2 ^N ms
22h	00000000h	Typical timeout for full chip erase 2 ^N ms (00h = not supported)
23h	00001010h	Max. timeout for byte/word write 2 ^N times typical
24h	00000505h	Max. timeout for buffer write 2 ^N times typical
25h	00000404h	Max. timeout per individual block erase 2 ^N times typical
26h	00000000h	Max. timeout for full chip erase 2 ^N times typical (00h = not supported)

Table 8. Device Geometry Definition

Addresses (x16)	Data	Description
27h	00001717h	Device Size = 2 ^N byte
28h 29h	00000101h 00000000h	Flash Device Interface description (refer to CFI publication 100)
2Ah 2Bh	00000505h 00000000h	Max. number of byte in multi-byte write = 2 ^N (00h = not supported)
2Ch	00000101h	Number of Erase Block Regions within device (01h = uniform device, 02h = boot device)
2Dh 2Eh 2Fh 30h	00007F7Fh 00000000h 00000000h 00000101h	Erase Block Region 1 Information (refer to the CFI specification or CFI publication 100)
31h 32h 33h 34h	00000000h 00000000h 00000000h 00000000h	Erase Block Region 2 Information (refer to CFI publication 100)
35h 36h 37h 38h	00000000h 00000000h 00000000h 00000000h	Erase Block Region 3 Information (refer to CFI publication 100)
39h 3Ah 3Bh 3Ch	00000000h 00000000h 00000000h 00000000h	Erase Block Region 4 Information (refer to CFI publication 100)

Table 9. Primary Vendor-Specific Extended Query

Addresses (x16)	Data	Description
40h 41h 42h	00005050h 00005252h 00004949h	Query-unique ASCII string "PRI"
43h	00003131h	Major version number, ASCII
44h	00003333h	Minor version number, ASCII
45h	000000808h	Address Sensitive Unlock (Bits 1-0) 0 = Required, 1 = Not Required Process Technology (Bits 7-2) 0010b = 0.23 μ m MirrorBit
46h	000000202h	Erase Suspend 0 = Not Supported, 1 = To Read Only, 2 = To Read & Write
47h	00000101h	Sector Protect 0 = Not Supported, X = Number of sectors in per group
48h	00000101h	Sector Temporary Unprotect 00 = Not Supported, 01 = Supported
49h	00000404h	Sector Protect/Unprotect scheme 04 = 29LV800 mode
4Ah	00000000h	Simultaneous Operation 00 = Not Supported, X = Number of Sectors in Bank
4Bh	00000000h	Burst Mode Type 00 = Not Supported, 01 = Supported
4Ch	00000101h	Page Mode Type 00 = Not Supported, 01 = 4 Word Page, 02 = 8 Word Page
4Dh	0000B5B5h	ACC (Acceleration) Supply Minimum 00h = Not Supported, D7-D4: Volt, D3-D0: 100 mV
4Eh	0000C5C5h	ACC (Acceleration) Supply Maximum 00h = Not Supported, D7-D4: Volt, D3-D0: 100 mV
4Fh	00000404h/ 00000505h	Top/Bottom Boot Sector Flag 00h = Uniform Device without WP# protect, 02h = Bottom Boot Device, 03h = Top Boot Device, 04h = Uniform sectors bottom WP# protect, 05h = Uniform sectors top WP# protect
50h	00000101h	Program Suspend 00h = Not Supported, 01h = Supported

Note: To reduce power consumption read Lower Byte only.

COMMAND DEFINITIONS

Writing specific address and data commands or sequences into the command register initiates device operations. Tables 10 and 11 define the valid register command sequences. *Writing incorrect address and data values or writing them in the improper sequence may place the device in an unknown state.* A reset command is then required to return the device to reading array data.

All addresses are latched on the falling edge of WE# or CE#, whichever happens later. All data is latched on the rising edge of WE# or CE#, whichever happens first. Refer to the AC Characteristics section for timing diagrams.

Reading Array Data

The device is automatically set to reading array data after device power-up. No commands are required to retrieve data. The device is ready to read array data after completing an Embedded Program or Embedded Erase algorithm.

After the device accepts an Erase Suspend command, the device enters the erase-suspend-read mode, after which the system can read data from any non-erase-suspended sector. After completing a programming operation in the Erase Suspend mode, the system may once again read array data with the same exception. See the Erase Suspend/Erase Resume Commands section for more information.

The system *must* issue the reset command to return the device to the read (or erase-suspend-read) mode if DQ5 or DQ13 goes high during an active program or erase operation, or if the device is in the autoselect mode. See the next section, Reset Command, for more information.

See also Requirements for Reading Array Data in the Device Bus Operations section for more information. The Read-Only Operations table provides the read parameters, and Figure 14 shows the timing diagram.

Reset Command

Writing the reset command resets the device to the read or erase-suspend-read mode. Address bits are don't cares for this command.

The reset command may be written between the sequence cycles in an erase command sequence before erasing begins. This resets the device to the read mode. Once erasure begins, however, the device ignores reset commands until the operation is complete.

The reset command may be written between the sequence cycles in a program command sequence before programming begins. This resets the device to

the read mode. If the program command sequence is written while the device is in the Erase Suspend mode, writing the reset command returns the device to the erase-suspend-read mode. Once programming begins, however, the device ignores reset commands until the operation is complete.

The reset command may be written between the sequence cycles in an autoselect command sequence. Once in the autoselect mode, the reset command must be written to return to the read mode. If the device entered the autoselect mode while in the Erase Suspend mode, writing the reset command returns the device to the erase-suspend-read mode.

If DQ5 or DQ13 goes high during a program or erase operation, writing the reset command returns the device to the read mode (or erase-suspend-read mode if the device was in Erase Suspend).

Note that if DQ1 or DQ9 goes high during a Write Buffer Programming operation, the system must write the Write-to-Buffer-Abort Reset command sequence to reset the device for the next operation.

Autoselect Command Sequence

The autoselect command sequence allows the host system to access the manufacturer and device codes, and determine whether or not a sector is protected. Table 11 shows the address and data requirements. This method is an alternative to that shown in Table 3, which is intended for PROM programmers and requires V_{ID} on address pin A9. The autoselect command sequence may be written to an address that is either in the read or erase-suspend-read mode. The autoselect command may not be written while the device is actively programming or erasing.

The autoselect command sequence is initiated by first writing two unlock cycles. This is followed by a third write cycle that contains the autoselect command. The device then enters the autoselect mode. The system may read at any address any number of times without initiating another autoselect command sequence:

- A read cycle at address XX00h returns the manufacturer code.
- Three read cycles at addresses 01h, 0Eh, and 0Fh return the device code.
- A read cycle to an address containing a sector address (SA), and the address 02h on A7–A0 in doubleword mode returns 0101h if the sector is protected, or 0000h if it is unprotected.

The system must write the reset command to return to the read mode (or erase-suspend-read mode if the device was previously in Erase Suspend).

Enter SecSi Sector/Exit SecSi Sector Command Sequence

The SecSi Sector region provides a secured data area containing an 8-doubleword/16-word random Electronic Serial Number (ESN). The system can access the SecSi Sector region by issuing the three-cycle Enter SecSi Sector command sequence. The device continues to access the SecSi Sector region until the system issues the four-cycle Exit SecSi Sector command sequence. The Exit SecSi Sector command sequence returns the device to normal operation. Tables 10 and 11 show the address and data requirements for both command sequences. See also “SecSi (Secured Silicon) Sector Flash Memory Region” for further information.

Doubleword/Word Program Command Sequence

Programming is a four-bus-cycle operation. The program command sequence is initiated by writing two unlock write cycles, followed by the program set-up command. The program address and data are written next, which in turn initiate the Embedded Program algorithm. The system is *not* required to provide further controls or timings. The device automatically provides internally generated program pulses and verifies the programmed cell margin. Tables 10 and 11 show the address and data requirements for the word program command sequence.

When the Embedded Program algorithm is complete, the device then returns to the read mode and addresses are no longer latched. The system can determine the status of the program operation by using DQ7 and DQ15 or DQ6 and DQ14. Refer to the Write Operation Status section for information on these status bits.

Any commands written to the device during the Embedded Program Algorithm are ignored. Note that a **hardware reset** immediately terminates the program operation. The program command sequence should be reinitiated once the device has returned to the read mode, to ensure data integrity.

Programming is allowed in any sequence and across sector boundaries. **A bit cannot be programmed from “0” back to a “1.”** Attempting to do so may cause the device to set DQ5 and/or DQ13 = 1, or cause the DQ7 and/or DQ15, and DQ6 and/or DQ14 status bits to indicate the operation was successful. However, a succeeding read will show that the data is still “0.” Only erase operations can convert a “0” to a “1.”

Unlock Bypass Command Sequence

The unlock bypass feature allows the system to program words to the device faster than using the stan-

dard program command sequence. The unlock bypass command sequence is initiated by first writing two unlock cycles. This is followed by a third write cycle containing the unlock bypass command, 2020h. The device then enters the unlock bypass mode. A two-cycle unlock bypass program command sequence is all that is required to program in this mode. The first cycle in this sequence contains the unlock bypass program command, A0A0h; the second cycle contains the program address and data. Additional data is programmed in the same manner. This mode dispenses with the initial two unlock cycles required in the standard program command sequence, resulting in faster total programming time. Tables 10 and 11 show the requirements for the command sequence.

During the unlock bypass mode, only the Unlock Bypass Program and Unlock Bypass Reset commands are valid. To exit the unlock bypass mode, the system must issue the two-cycle unlock bypass reset command sequence. The first cycle must contain the data 9090h. The second cycle must contain the data 00h. The device then returns to the read mode.

Write Buffer Programming

Write Buffer Programming allows the system write to a maximum of 16 doublewords/32 words in one programming operation. This results in faster effective programming time than the standard programming algorithms. The Write Buffer Programming command sequence is initiated by first writing two unlock cycles. This is followed by a third write cycle containing the Write Buffer Load command written at the Sector Address in which programming will occur. The fourth cycle writes the sector address and the number of word locations, minus one, to be programmed. For example, if the system will program 6 unique address locations, then 0505h should be written to the device. This tells the device how many write buffer addresses will be loaded with data and therefore when to expect the Program Buffer to Flash command. The number of locations to program cannot exceed the size of the write buffer or the operation will abort.

The fifth cycle writes the first address location and data to be programmed. The write-buffer-page is selected by address bits A23–A4. All subsequent address/data pairs must fall within the selected-write-buffer-page. The system then writes the remaining address/data pairs into the write buffer. Write buffer locations may be loaded in any order.

The write-buffer-page address must be the same for all address/data pairs loaded into the write buffer. (This means Write Buffer Programming cannot be performed across multiple write-buffer pages. This also means that Write Buffer Programming cannot be performed across multiple sectors. If the system attempts

to load programming data outside of the selected write-buffer page, the operation will abort.

Note that if a Write Buffer address location is loaded multiple times, the address/data pair counter will be decremented for every data load operation. The host system must therefore account for loading a write-buffer location more than once. The counter decrements for each data load operation, not for each unique write-buffer-address location. Note also that if an address location is loaded more than once into the buffer, the final data loaded for that address will be programmed.

Once the specified number of write buffer locations have been loaded, the system must then write the Program Buffer to Flash command at the sector address. Any other address and data combination aborts the Write Buffer Programming operation. The device then begins programming. Data polling should be used while monitoring the last address location loaded into the write buffer. DQ7 and DQ15, DQ6 and DQ14, DQ5 and DQ13, and DQ1 and DQ9 should be monitored to determine the device status during Write Buffer Programming.

The write-buffer programming operation can be suspended using the standard program suspend/resume commands. Upon successful completion of the Write Buffer Programming operation, the device is ready to execute the next command.

The Write Buffer Programming Sequence can be aborted in the following ways:

- Load a value that is greater than the page buffer size during the Number of Locations to Program step.
- Write to an address in a sector different than the one specified during the Write-Buffer-Load command.
- Write an Address/Data pair to a different write-buffer-page than the one selected by the

Starting Address during the write buffer data loading stage of the operation.

- Write data other than the Confirm Command after the specified number of data load cycles.

The abort condition is indicated by DQ1 and DQ9 = 1, DQ7 and DQ15 = DATA# (for the last address location loaded), DQ6 and DQ14 = toggle, and DQ5 and DQ13 = 0. A Write-to-Buffer-Abort Reset command sequence must be written to reset the device for the next operation. Note that the full 3-cycle Write-to-Buffer-Abort Reset command sequence is required when using Write-Buffer-Programming features in Unlock Bypass mode.

Programming is allowed in any sequence and across sector boundaries. **A bit cannot be programmed from “0” back to a “1.”** Attempting to do so may cause the device to set DQ5 and/or DQ13 = 1, or cause the DQ7 and/or DQ15 and DQ6 and/or DQ14 status bits to indicate the operation was successful. However, a succeeding read will show that the data is still “0.” Only erase operations can convert a “0” to a “1.”

Accelerated Program

The device offers accelerated program operations through the WP#/ACC pin. When the system asserts V_{HH} on the WP#/ACC pin, the device automatically enters the Unlock Bypass mode. The system may then write the two-cycle Unlock Bypass program command sequence. The device uses the higher voltage on the WP#/ACC pin to accelerate the operation. *Note that the WP#/ACC pin must not be at V_{HH} for operations other than accelerated programming, or device damage may result. WP# has an internal pullup; when unconnected, WP# is at V_{IH} .*

Figure 5 illustrates the algorithm for the program operation. Refer to the Erase and Program Operations table in the AC Characteristics section for parameters, and Figure 17 for timing diagrams.

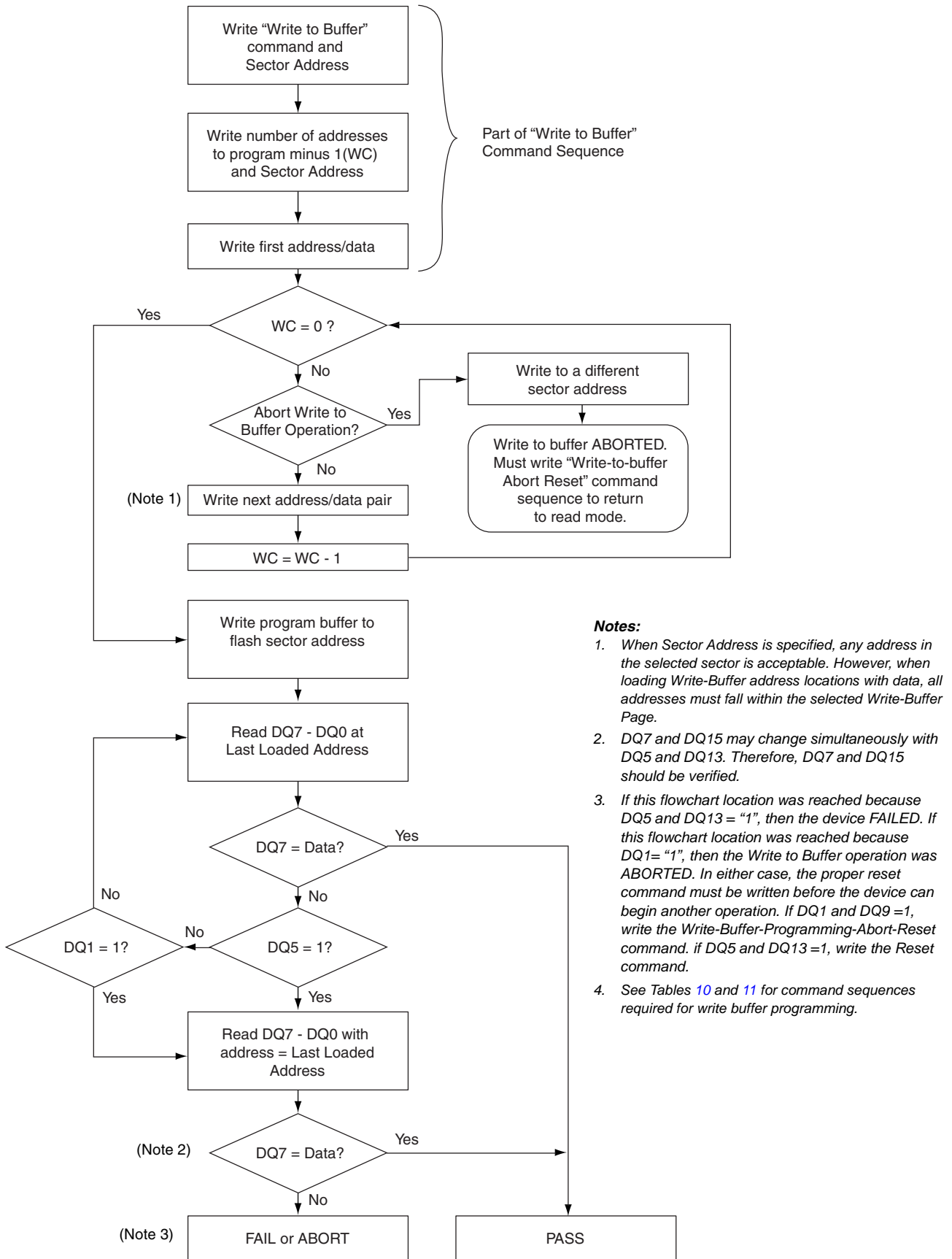
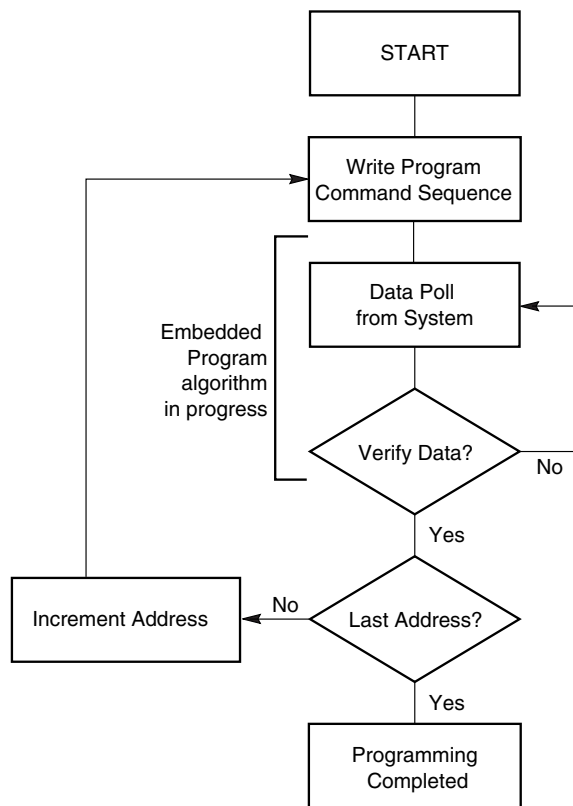

Figure 4. Write Buffer Programming Operation



Note: See Tables 10 and 11 for program command sequence.

Figure 5. Program Operation

Program Suspend/Program Resume Command Sequence

The Program Suspend command allows the system to interrupt a programming operation or a Write to Buffer programming operation so that data can be read from any non-suspended sector. When the Program Suspend command is written during a programming process, the device halts the program operation within 15 μs max (5 μs typical) and updates the status bits. Addresses are not required when writing the Program Suspend command.

After the programming operation has been suspended, the system can read array data from any non-suspended sector. The Program Suspend command may also be issued during a programming operation while an erase is suspended. In this case, data may be read from any addresses not in Erase Suspend or Program Suspend. If a read is needed from the SecSi Sector area (One-time Program area), then user must use the proper command sequences to enter and exit this region.

The system may also write the autoselect command sequence when the device is in the Program Suspend mode. The system can read as many autoselect codes as required. When the device exits the autoselect mode, the device reverts to the Program Suspend mode, and is ready for another valid operation. See Autoselect Command Sequence for more information.

After the Program Resume command is written, the device reverts to programming. The system can determine the status of the program operation using the DQ7 and DQ15 or DQ6 and DQ14 status bits, just as in the standard program operation. See Write Operation Status for more information.

The system must write the Program Resume command (address bits are don't care) to exit the Program Suspend mode and continue the programming operation. Further writes of the Resume command are ignored. Another Program Suspend command can be written after the device has resume programming.

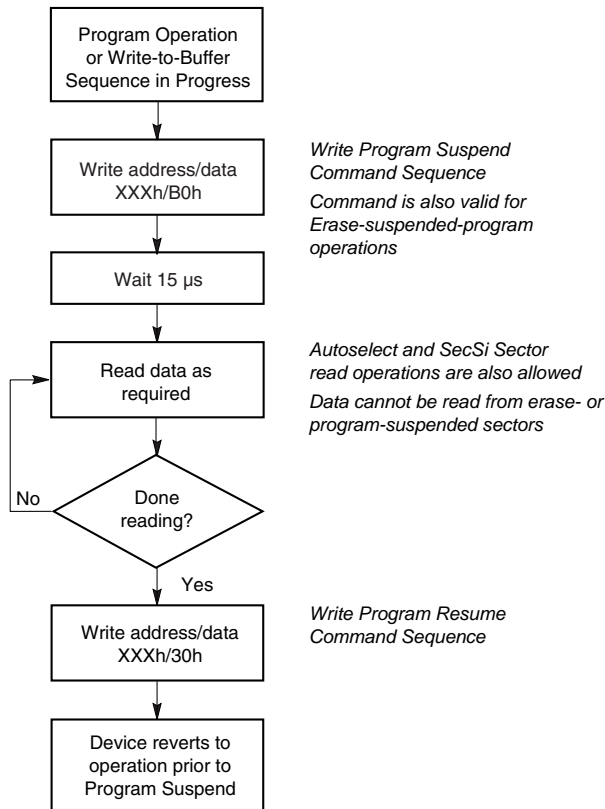

Figure 6. Program Suspend/Program Resume

Chip Erase Command Sequence

Chip erase is a six bus cycle operation. The chip erase command sequence is initiated by writing two unlock cycles, followed by a set-up command. Two additional unlock write cycles are then followed by the chip erase command, which in turn invokes the Embedded Erase algorithm. The device does *not* require the system to preprogram prior to erase. The Embedded Erase algorithm automatically preprograms and verifies the entire memory for an all zero data pattern prior to electrical erase. The system is not required to provide any controls or timings during these operations. Tables 10 and 11 show the address and data requirements for the chip erase command sequence.

When the Embedded Erase algorithm is complete, the device returns to the read mode and addresses are no longer latched. The system can determine the status of the erase operation by using DQ7 and DQ15, DQ6 and DQ14, or DQ2 and DQ10. Refer to the Write Operation Status section for information on these status bits.

Any commands written during the chip erase operation are ignored. However, note that a **hardware reset** immediately terminates the erase operation. If that occurs, the chip erase command sequence should be reinitiated once the device has returned to reading array data, to ensure data integrity.

Figure 7 illustrates the algorithm for the erase operation. Refer to the Erase and Program Operations tables in the AC Characteristics section for parameters, and Figure 19 section for timing diagrams.

Sector Erase Command Sequence

Sector erase is a six bus cycle operation. The sector erase command sequence is initiated by writing two unlock cycles, followed by a set-up command. Two additional unlock cycles are written, and are then followed by the address of the sector to be erased, and the sector erase command. Table 11 shows the address and data requirements for the sector erase command sequence.

The device does *not* require the system to preprogram prior to erase. The Embedded Erase algorithm automatically programs and verifies the entire memory for an all zero data pattern prior to electrical erase. The system is not required to provide any controls or timings during these operations.

After the command sequence is written, a sector erase time-out of 50 μ s occurs. During the time-out period, additional sector addresses and sector erase commands may be written. Loading the sector erase buffer may be done in any sequence, and the number of sectors may be from one sector to all sectors. The time between these additional cycles must be less than 50 μ s, otherwise erasure may begin. Any sector erase address and command following the exceeded time-out may or may not be accepted. It is recommended that processor interrupts be disabled during this time to ensure all commands are accepted. The interrupts can be re-enabled after the last Sector Erase command is written. **Any command other than Sector Erase or Erase Suspend during the time-out period resets the device to the read mode.** The system must re-write the command sequence and any additional addresses and commands.

The system can monitor DQ3 and DQ11 to determine if the sector erase timer has timed out (See the section on DQ3 and DQ11: Sector Erase Timer.). The time-out

begins from the rising edge of the final WE# pulse in the command sequence.

When the Embedded Erase algorithm is complete, the device returns to reading array data and addresses are no longer latched. Note that while the Embedded Erase operation is in progress, the system can read data from the non-erasing sector. The system can determine the status of the erase operation by reading DQ7 and DQ15, DQ6 and DQ14, or DQ2 and DQ10 in the erasing sector. Refer to the Write Operation Status section for information on these status bits.

Once the sector erase operation has begun, only the Erase Suspend command is valid. All other commands are ignored. However, note that a **hardware reset** immediately terminates the erase operation. If that occurs, the sector erase command sequence should be reinitiated once the device has returned to reading array data, to ensure data integrity.

Figure 7 illustrates the algorithm for the erase operation. Refer to the Erase and Program Operations tables in the AC Characteristics section for parameters, and Figure 19 section for timing diagrams.

Erase Suspend/Erase Resume Commands

The Erase Suspend command, B0h, allows the system to interrupt a sector erase operation and then read data from, or program data to, any sector not selected for erasure. This command is valid only during the sector erase operation, including the 50 μ s time-out period during the sector erase command sequence. The Erase Suspend command is ignored if written during the chip erase operation or Embedded Program algorithm.

When the Erase Suspend command is written during the sector erase operation, the device requires a typical of 5 μ s (maximum of 20 μ s) to suspend the erase operation. However, when the Erase Suspend command is written during the sector erase time-out, the device immediately terminates the time-out period and suspends the erase operation.

After the erase operation has been suspended, the device enters the erase-suspend-read mode. The system can read data from or program data to any sector not selected for erasure. (The device “erase suspends” all sectors selected for erasure.) Reading at any address within erase-suspended sectors produces status information on DQ15–DQ0. The system can use DQ7 and DQ15, or DQ6 and DQ14 and DQ2 and DQ10 together, to determine if a sector is actively erasing or is erase-suspended. Refer to the Write Operation Status section for information on these status bits.

After an erase-suspended program operation is complete, the device returns to the erase-suspend-read mode. The system can determine the status of the program operation using the DQ7 and DQ15 or DQ6 and DQ14 status bits, just as in the standard word program operation. Refer to the Write Operation Status section for more information.

In the erase-suspend-read mode, the system can also issue the autoselect command sequence. Refer to the Autoselect Mode and Autoselect Command Sequence sections for details.

To resume the sector erase operation, the system must write the Erase Resume command. Further writes of the Resume command are ignored. Another Erase Suspend command can be written after the chip has resumed erasing.

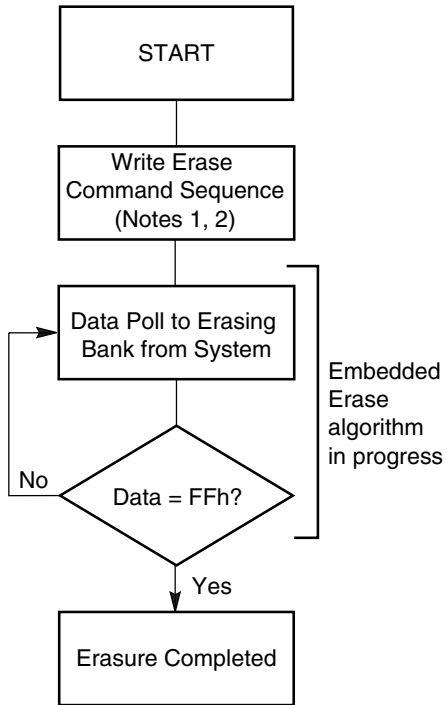
**Notes:**

1. See Tables 10 and 11 for program command sequence.
2. See the section on DQ3 and DQ10 for information on the sector erase timer.

Figure 7. Erase Operation

Command Definitions

Table 10. Command Definitions (x32 Mode, WORD# = V_{IH})

Command Sequence (Note 1)	Cycles	Bus Cycles (Notes 2–5)												
		First		Second		Third		Fourth		Fifth		Sixth		
		Addr	Data	Addr	Data	Addr	Data	Addr	Data	Addr	Data	Addr	Data	
Read (Note 6)	1	RA	RD											
Reset (Note 7)	1	XXX	F0F0											
Autoselect (Note 8)	Manufacturer ID	4	555	AAAA	2AA	5555	555	9090	X00	00000101				
	Device ID (Note 9)	6	555	AAAA	2AA	5555	555	9090	X01	2222 7E7E	X0E	2222 0C0C	X0F	2222 0101
	SecSi™ Sector Factory Protect (Note 10)	4	555	AAAA	2AA	5555	555	9090	X03	(Note 10)				
	Sector Protect Verify (Note 12)	4	555	AAAA	2AA	5555	555	9090	(SA)X02	0000/ 0101				
Enter SecSi Sector Region	3	555	AAAA	2AA	5555	555	8888							
Exit SecSi Sector Region	4	555	AAAA	2AA	5555	555	9090	XXX	0000					
Program	4	555	AAAA	2AA	5555	555	A0A0	PA	PD					
Write to Buffer (Note 11)	3	555	AAAA	2AA	5555	SA	2525	SA	DWC	PA	PD	WBL	PD	
Program Buffer to Flash	1	SA	2929											
Write to Buffer Abort Reset (Note 13)	3	555	AAAA	2AA	5555	555	F0F0							
Unlock Bypass	3	555	AAAA	2AA	5555	555	2020							
Unlock Bypass Program (Note 14)	2	XXX	A0A0	PA	PD									
Unlock Bypass Reset (Note 15)	2	XXX	9090	XXX	0000									
Chip Erase	6	555	AAAA	2AA	5555	555	8080	555	AAAA	2AA	5555	555	1010	
Sector Erase	6	555	AAAA	2AA	5555	555	8080	555	AAAA	2AA	5555	SA	3030	
Program/Erase Suspend (Note 16)	1	XXX	B0B0											
Program/Erase Resume (Note 17)	1	XXX	3030											
CFI Query (Note 18)	1	55	9898											

Legend:

X = Don't care

RA = Read Address of the memory location to be read.

RD = Read Data read from location RA during read operation.

PA = Program Address. Addresses latch on the falling edge of the WE# or CE# pulse, whichever happens later.

PD = Program Data for location PA. Data latches on the rising edge of WE# or CE# pulse, whichever happens first.

SA = Sector Address of sector to be verified (in autoselect mode) or erased. Address bits A21–A15 uniquely select any sector.

WBL = Write Buffer Location. Address must be within the same write buffer page as PA.

DWC = Doubleword Count. Number of write buffer locations to load minus 1.

Notes:

- See Table 1 for description of bus operations.
- All values are in hexadecimal.
- Except for the read cycle and the fourth cycle of the autoselect command sequence, all bus cycles are write cycles.
- Data bits DQ31–DQ16 are don't care in command sequences, except for RD, PD, and DWC.
- Unless otherwise noted, address bits A21–A11 are don't cares.
- No unlock or command cycles required when device is in read mode.
- The Reset command is required to return to the read mode (or to the erase-suspend-read mode if previously in Erase Suspend) when the device is in the autoselect mode, or if DQ5 and/or DQ13 goes high while the device is providing status information.
- The fourth cycle of the autoselect command sequence is a read cycle. Data bits DQ31–DQ16 are don't care. See the Autoselect Command Sequence section for more information.
- The device ID must be read in three cycles.
- If WP# protects the highest address sector, the data is 9898h for factory locked and 1818h for not factory locked. If WP# protects the lowest address sector, the data is 8888h for factory locked and 0808h for not factor locked.
- The total number of cycles in the command sequence is determined by the number of doublewords written to the write buffer. The maximum number of cycles in the command sequence is 21.
- The data is 0000h for an unprotected sector and 0101h for a protected sector.
- Command sequence resets device for next command after aborted write-to-buffer operation.
- The Unlock Bypass command is required prior to the Unlock Bypass Program command.
- The Unlock Bypass Reset command is required to return to the read mode when the device is in the unlock bypass mode.
- The system may read and program in non-erasing sectors, or enter the autoselect mode, when in the Erase Suspend mode. The Erase Suspend command is valid only during a sector erase operation.
- The Erase Resume command is valid only during the Erase Suspend mode.
- Command is valid when device is ready to read array data or when device is in autoselect mode.

Table 11. Command Definitions (x16 Mode, WORD# = V_{IL})

Command Sequence (Note 1)	Cycles	Bus Cycles (Notes 2–5)											
		First		Second		Third		Fourth		Fifth		Sixth	
		Addr	Data	Addr	Data	Addr	Data	Addr	Data	Addr	Data	Addr	Data
Read (Note 6)	1	RA	RD										
Reset (Note 7)	1	XXX	F0F0										
Autoselect (Note 8)	Manufacturer ID	4	AAA	AAAA	555	5555	AAA	9090	X00	0101			
	Device ID (Note 9)	6	AAA	AAAA	555	5555	AAA	9090	X02	7E7E	X1C	0C0C	X1E 0101
	SecSi™ Sector Factory Protect (Note 10)	4	AAA	AAAA	555	5555	AAA	9090	X06	(Note 10)			
	Sector Protect Verify (Note 12)	4	AAA	AAAA	555	5555	AAA	9090	(SA)X04	0000/0101			
Enter SecSi Sector Region	3	AAA	AAAA	555	5555	AAA	8888						
Exit SecSi Sector Region	4	AAA	AAAA	555	5555	AAA	9090	XXX	0000				
Program	4	AAA	AAAA	555	5555	AAA	A0A0	PA	PD				
Write to Buffer (Note 11)	3	AAA	AAAA	555	5555	SA	2525	SA	WC	PA	PD	WBL	PD
Program Buffer to Flash	1	SA	2929										
Write to Buffer Abort Reset (Note 13)	3	AAA	AAAA	555	5555	AAA	F0F0						
Unlock Bypass	3	AAA	AAAA	555	5555	AAA	2020						
Unlock Bypass Program (Note 14)	2	XXX	A0A0	PA	PD								
Unlock Bypass Reset (Note 15)	2	XXX	9090	XXX	0000								
Chip Erase	6	AAA	AAAA	555	5555	AAA	8080	AAA	AAAA	555	5555	AAA	1010
Sector Erase	6	AAA	AAAA	555	5555	AAA	8080	AAA	AAAA	555	5555	SA	3030
Program/Erase Suspend (Note 16)	1	XXX	B0B0										
Program/Erase Resume (Note 17)	1	XXX	3030										
CFI Query (Note 18)	1	AA	9898										

Legend:

X = Don't care

RA = Read Address of the memory location to be read.

RD = Read Data read from location RA during read operation.

PA = Program Address. Addresses latch on the falling edge of the WE# or CE# pulse, whichever happens later.

PD = Program Data for location PA. Data latches on the rising edge of WE# or CE# pulse, whichever happens first.

SA = Sector Address of sector to be verified (in autoselect mode) or erased. Address bits A21–A15 uniquely select any sector.

WBL = Write Buffer Location. Address must be within the same write buffer page as PA.

WC = Word Count. Number of write buffer locations to load minus 1.

Notes:

- See Table 1 for description of bus operations.
- All values are in hexadecimal.
- Except for the read cycle and the fourth cycle of the autoselect command sequence, all bus cycles are write cycles.
- Data bits DQ31–DQ15 are don't care in command sequences.
- Unless otherwise noted, address bits A21–A11 are don't cares.
- No unlock or command cycles required when device is in read mode.
- The Reset command is required to return to the read mode (or to the erase-suspend-read mode if previously in Erase Suspend) when the device is in the autoselect mode, or if DQ5 and/or DQ13 goes high while the device is providing status information.
- The fourth cycle of the autoselect command sequence is a read cycle. Data bits DQ31–DQ16 are don't care. See the Autoselect Command Sequence section for more information.
- The device ID must be read in three cycles.
- If WP# protects the highest address sector, the data is 9898h for factory locked and 1818h for not factory locked. If WP# protects the lowest address sector, the data is 8888h for factory locked and 0808h for not factor locked.
- The total number of cycles in the command sequence is determined by the number of words written to the write buffer. The maximum number of cycles in the command sequence is 37.
- The data is 0000h for an unprotected sector group and 0101h for a protected sector group.
- Command sequence resets device for next command after aborted write-to-buffer operation.
- The Unlock Bypass command is required prior to the Unlock Bypass Program command.
- The Unlock Bypass Reset command is required to return to the read mode when the device is in the unlock bypass mode.
- The system may read and program in non-erasing sectors, or enter the autoselect mode, when in the Erase Suspend mode. The Erase Suspend command is valid only during a sector erase operation.
- The Erase Resume command is valid only during the Erase Suspend mode.
- Command is valid when device is ready to read array data or when device is in autoselect mode.

WRITE OPERATION STATUS

The device provides several bits to determine the status of a program or erase operation: DQ2 and DQ10, DQ3 and DQ11, DQ5 and DQ13, DQ6 and DQ14, and DQ7 and DQ15. Table 12 and the following subsections describe the function of these bits. DQ7 and DQ15 and DQ6 and DQ14 each offer a method for determining whether a program or erase operation is complete or in progress. The device also provides a hardware-based output signal, RY/BY#, to determine whether an Embedded Program or Erase operation is in progress or has been completed.

DQ7 and DQ5: Data# Polling

The Data# Polling bit, DQ7 and DQ15, indicates to the host system whether an Embedded Program or Erase algorithm is in progress or completed, or whether the device is in Erase Suspend. Data# Polling is valid after the rising edge of the final WE# pulse in the command sequence.

During the Embedded Program algorithm, the device outputs on DQ7 and DQ15 the complement of the datum programmed to DQ7 and DQ15. This DQ7 and DQ15 status also applies to programming during Erase Suspend. When the Embedded Program algorithm is complete, the device outputs the datum programmed to DQ7 and DQ15. The system must provide the program address to read valid status information on DQ7 and DQ15. If a program address falls within a protected sector, Data# Polling on DQ7 and DQ15 is active for approximately 1 μ s, then the device returns to the read mode.

During the Embedded Erase algorithm, Data# Polling produces a "0" on DQ7 and DQ15. When the Embedded Erase algorithm is complete, or if the device enters the Erase Suspend mode, Data# Polling produces a "1" on DQ7 and DQ15. The system must provide an address within any of the sectors selected for erasure to read valid status information on DQ7 and DQ15.

After an erase command sequence is written, if all sectors selected for erasing are protected, Data# Polling on DQ7 and DQ15 is active for approximately 100 μ s, then the device returns to the read mode. If not all selected sectors are protected, the Embedded Erase algorithm erases the unprotected sectors, and ignores the selected sectors that are protected. However, if the system reads DQ7 and DQ15 at an address within a protected sector, the status may not be valid.

Just prior to the completion of an Embedded Program or Erase operation, DQ7 and DQ15 may change asynchronously with DQ6–DQ0 and DQ14–DQ8 while Output Enable (OE#) is asserted low. That is, the device may change from providing status information to valid data on DQ7 and DQ15. Depending on when the system samples the DQ7 and DQ15 output, it may read the status or valid data. Even if the device has com-

pleted the program or erase operation and DQ7 has valid data, the data outputs on DQ6–DQ0 and DQ14–DQ8 may be still invalid. Valid data on DQ15–DQ0 will appear on successive read cycles.

Table 12 shows the outputs for Data# Polling on DQ7 and DQ15. Figure 8 shows the Data# Polling algorithm. Figure 20 in the AC Characteristics section shows the Data# Polling timing diagram.

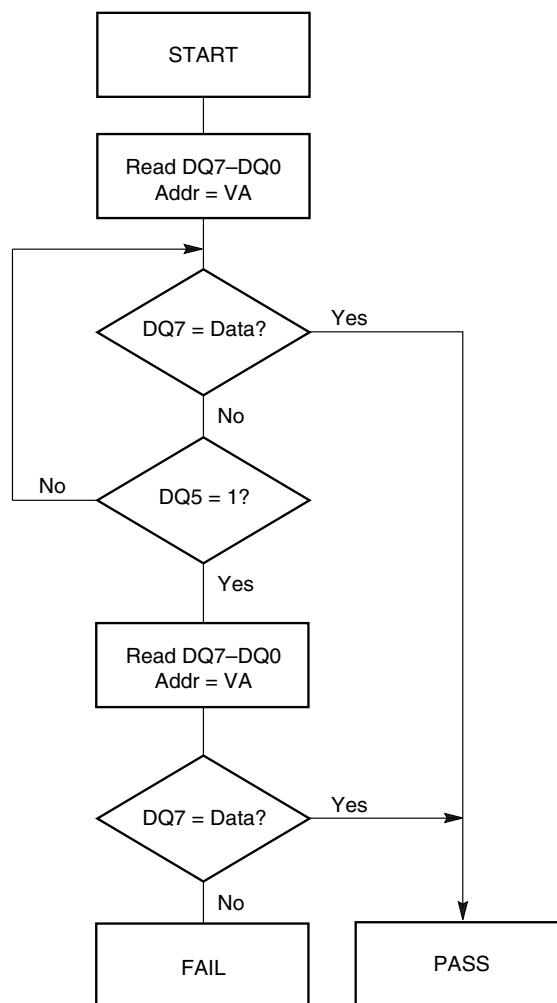

Notes:

1. VA = Valid address for programming. During a sector erase operation, a valid address is any sector address within the sector being erased. During chip erase, a valid address is any non-protected sector address.
2. DQ7 and DQ15 should be rechecked even if DQ5 and/or DQ13 = "1" because DQ7 and DQ15 may change simultaneously with DQ5 and DQ13.

Figure 8. Data# Polling Algorithm

RY/BY#: Ready/Busy#

The RY/BY# is a dedicated, open-drain output pin which indicates whether an Embedded Algorithm is in progress or complete. The RY/BY# status is valid after the rising edge of the final WE# pulse in the command sequence. Since RY/BY# is an open-drain output, several RY/BY# pins can be tied together in parallel with a pull-up resistor to V_{CC}.

If the output is low (Busy), the device is actively erasing or programming. (This includes programming in the Erase Suspend mode.) If the output is high (Ready), the device is in the read mode, the standby mode, or in the erase-suspend-read mode. Table 12 shows the outputs for RY/BY#.

DQ6 and DQ14: Toggle Bits I

Toggle Bit I on DQ6 and DQ14 indicates whether an Embedded Program or Erase algorithm is in progress or complete, or whether the device has entered the Erase Suspend mode. Toggle Bit I may be read at any address, and is valid after the rising edge of the final WE# pulse in the command sequence (prior to the program or erase operation), and during the sector erase time-out.

During an Embedded Program or Erase algorithm operation, successive read cycles to any address cause DQ6 and DQ14 to toggle. The system may use either OE# or CE# to control the read cycles. When the operation is complete, DQ6 and DQ14 stops toggling.

After an erase command sequence is written, if all sectors selected for erasing are protected, DQ6 and DQ14 toggles for approximately 100 μ s, then returns to reading array data. If not all selected sectors are protected, the Embedded Erase algorithm erases the unprotected sectors, and ignores the selected sectors that are protected.

The system can use DQ6 and DQ14 and DQ2 and DQ10 together to determine whether a sector is actively erasing or is erase-suspended. When the device is actively erasing (that is, the Embedded Erase algorithm is in progress), DQ6 and DQ14 toggle. When the device enters the Erase Suspend mode, DQ6 and DQ14 stop toggling. However, the system must also use DQ2 and DQ10 to determine which sectors are erasing or erase-suspended. Alternatively, the system can use DQ7 and DQ15 (see the subsection on DQ7 and DQ15: Data# Polling).

If a program address falls within a protected sector, DQ6 and DQ14 toggle for approximately 1 μ s after the program command sequence is written, then returns to reading array data.

DQ6 and DQ14 also toggle during the erase-suspend-program mode, and stops toggling once the Embedded Program algorithm is complete.

Table 12 shows the outputs for Toggle Bit I on DQ6 and DQ14. Figure 9 shows the toggle bit algorithm. Figure 21 in the “AC Characteristics” section shows the toggle bit timing diagrams. Figure 22 shows the differences between DQ2 and DQ10 and DQ6 and DQ14 in graphical form. See also the subsection on DQ2 and DQ10: Toggle Bits II.

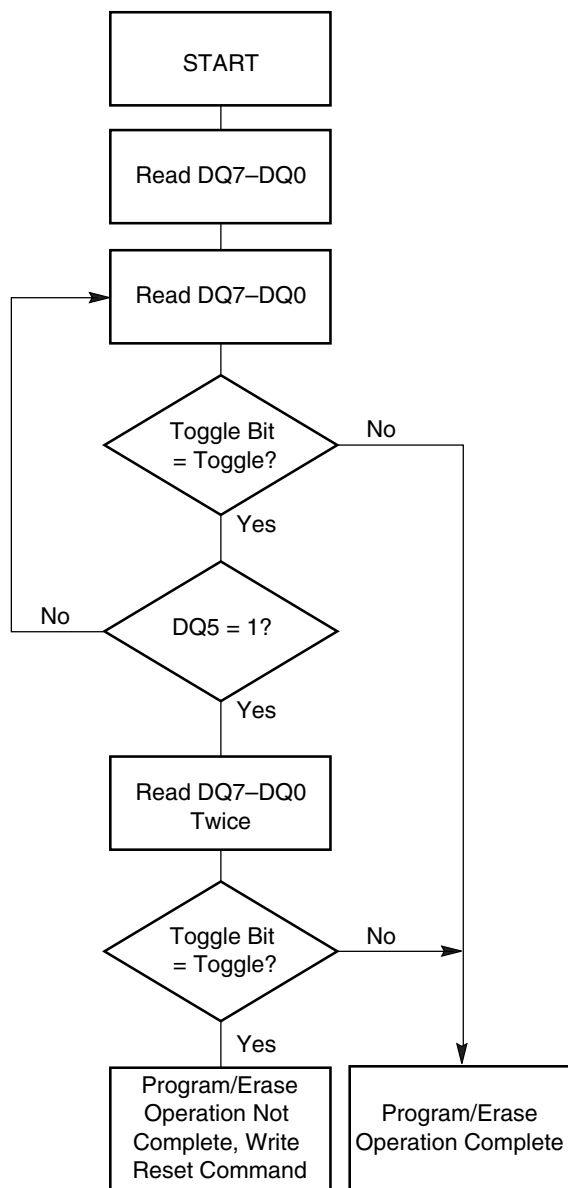

Note: The system should recheck the toggle bit even if DQ5 and DQ13= "1" because the toggle bit may stop toggling as DQ5 and DQ13 changes to "1." See the subsections on DQ6 and DQ14 and DQ2 and DQ10 for more information.

Figure 9. Toggle Bit Algorithm

DQ2 and DQ10: Toggle Bits II

The "Toggle Bits II" on DQ2 and DQ10, when used with DQ6 and DQ14, indicate whether a particular sector is actively erasing (that is, the Embedded Erase algorithm is in progress), or whether that sector is erase-suspended. Toggle Bits II are valid after the rising edge of the final WE# pulse in the command sequence.

DQ2 and DQ10 toggle when the system reads at addresses within those sectors that have been selected for erasure. (The system may use either OE# or CE# to control the read cycles.) But DQ2 and DQ10 cannot distinguish whether the sector is actively erasing or is erase-suspended. DQ6 and DQ14, by comparison, indicate whether the device is actively erasing, or is in Erase Suspend, but cannot distinguish which sectors are selected for erasure. Thus, both status bits are required for sector and mode information. Refer to Table 12 to compare outputs for DQ2 and DQ10 and DQ6 and DQ14.

Figure 9 shows the toggle bit algorithm in flowchart form, and the section "DQ2 and DQ10: Toggle Bits II" explains the algorithm. See also the RY/BY#: Ready/Busy# subsection. Figure 21 shows the toggle bit timing diagram. Figure 22 shows the differences between DQ2 and DQ10 and DQ6 and DQ14 in graphical form.

Reading Toggle Bits DQ6 and DQ14/DQ2 and DQ10

Refer to Figure 9 for the following discussion. Whenever the system initially begins reading toggle bits status, it must read DQ15–DQ0 at least twice in a row to determine whether a toggle bit is toggling. Typically, the system would note and store the value of the toggle bit after the first read. After the second read, the system would compare the new value of the toggle bit with the first. If the toggle bits are not toggling, the device has completed the program or erase operation. The system can read array data on DQ15–DQ0 on the following read cycle.

However, if after the initial two read cycles, the system determines that one of the toggle bits are still toggling, the system also should note whether the value of DQ5 and DQ13 is high (see the section on DQ5 and DQ13). If it is, the system should then determine again whether the toggle bit is toggling, since the toggle bit may have stopped toggling just as DQ5 and/or DQ13 went high. If the toggle bits are no longer toggling, the device has successfully completed the program or erase operation. If it is still toggling, the device did not completed the operation successfully, and the system must write the reset command to return to reading array data.

The remaining scenario is that the system initially determines that the toggle bit is toggling and DQ5 and/or DQ13 has not gone high. The system may continue to monitor the toggle bits and DQ5 and DQ13 through successive read cycles, determining the status as described in the previous paragraph. Alternatively, it may choose to perform other system tasks. In this case, the system must start at the beginning of the algorithm when it returns to determine the status of the operation (top of Figure 9).

DQ5 and DQ13: Exceeded Timing Limits

DQ5 indicates whether the program, erase, or write-to-buffer time has exceeded a specified internal pulse count limit. Under these conditions DQ5 and DQ13 produce a “1,” indicating that the program or erase cycle was not successfully completed.

The device may output a “1” on DQ5 and/or DQ13 if the system tries to program a “1” to a location that was previously programmed to “0.” **Only an erase operation can change a “0” back to a “1.”** Under this condition, the device halts the operation, and when the timing limit has been exceeded, DQ5 and/or DQ13 produces a “1.”

In all these cases, the system must write the reset command to return the device to the reading the array (or to erase-suspend-read if the device was previously in the erase-suspend-program mode).

DQ3 and DQ11: Sector Erase Timer

After writing a sector erase command sequence, the system may read DQ3 and DQ11 to determine whether or not erasure has begun. (The sector erase timer does not apply to the chip erase command.) If additional sectors are selected for erasure, the entire time-out also applies after each additional sector erase command. When the time-out period is complete, DQ3 and DQ11 switch from a “0” to a “1.” If the time between additional sector erase commands from the system can be assumed to be less than 50 μ s, the system need not monitor DQ3 and DQ11. See also the Sector Erase Command Sequence section.

After the sector erase command is written, the system should read the status of DQ7 and DQ15 (Data# Polling) or DQ6 and DQ14 (Toggle Bits I) to ensure that the device has accepted the command sequence, and then read DQ3 and DQ11. If DQ3 and DQ11 are “1,” the Embedded Erase algorithm has begun; all further commands (except Erase Suspend) are ignored until the erase operation is complete. If DQ3 and DQ11 are “0,” the device will accept additional sector erase commands. To ensure the command has been accepted, the system software should check the status of DQ3 and DQ11 prior to and following each subsequent sector erase command. If DQ3 and DQ11 are high on the second status check, the last command might not have been accepted.

Table 12 shows the status of DQ3 and DQ11 relative to the other status bits.

DQ1: Write-to-Buffer Abort

DQ1 indicates whether a Write-to-Buffer operation was aborted. Under these conditions DQ1 and DQ9 produce a “1”. The system must issue the

Write-to-Buffer-Abort-Reset command sequence to return the device to reading array data. See Write Buffer Programming section for more details.

Table 12. Write Operation Status

Status		DQ7/DQ15 (Note 2)	DQ6/DQ14	DQ5/ DA13 (Note 1)	DQ3/ DQ11	DQ2/DQ10 (Note 2)	DQ1/ DQ9	RY/BY#	
Standard Mode	Embedded Program Algorithm	DQ7/DA15#	Toggle	0	N/A	No toggle	0	0	
	Embedded Erase Algorithm	0	Toggle	0	1	Toggle	N/A	0	
Program Suspend Mode	Program-Suspend Sector	Invalid (not allowed)						1	
	Non-Program Suspend Sector	Data						1	
Erase Suspend Mode	Erase-Suspend Read	Erase-Suspend Sector	1	No toggle	0	N/A	Toggle	N/A	1
		Non-Erase Suspend Sector	Data						1
	Erase-Suspend-Program (Embedded Program)	DQ7/DQ15#	Toggle	0	N/A	N/A	N/A	0	
Write-to-Buffer	Busy (Note 3)	DQ7/DQ15#	Toggle	0	N/A	N/A	0	0	
	Abort (Note 4)	DQ7/DQ15#	Toggle	0	N/A	N/A	1	0	

Notes:

1. DQ5 and DQ13 switch to ‘1’ when an Embedded Program, Embedded Erase, or Write-to-Buffer operation has exceeded the maximum timing limits. Refer to the section on DQ5 and DQ13 for more information.
2. DQ7 and DQ15 and DQ2 and DQ10 require a valid address when reading status information. Refer to the appropriate subsection for further details.
3. The Data# Polling algorithm should be used to monitor the last loaded write-buffer address location.
4. DQ1 and DQ9 switch to ‘1’ when the device has aborted the write-to-buffer operation.

ABSOLUTE MAXIMUM RATINGS

Storage Temperature	
Plastic Packages	-65°C to +150°C
Ambient Temperature	
with Power Applied.	-55°C to +125°C
Voltage with Respect to Ground	
V_{CC} (Note 1)	-0.5 V to +4.0 V
A9, OE#, WP#/ACC, and RESET#	
(Note 2).	-0.5 V to +12.5 V
All other pins (Note 1)	-0.5 V to $V_{CC} + 0.5$ V
Output Short Circuit Current (Note 3)	200 mA

Notes:

1. Minimum DC voltage on input or I/O pins is -0.5 V. During voltage transitions, input or I/O pins may overshoot V_{SS} to -2.0 V for periods of up to 20 ns. Maximum DC voltage on input or I/O pins is $V_{CC} + 0.5$ V. See Figure 10. During voltage transitions, input or I/O pins may overshoot to $V_{CC} + 2.0$ V for periods up to 20 ns. See Figure 11.
2. Minimum DC input voltage on pins A9, OE#, ACC, and RESET# is -0.5 V. During voltage transitions, A9, OE#, WP#/ACC, and RESET# may overshoot V_{SS} to -2.0 V for periods of up to 20 ns. See Figure 10. Maximum DC input voltage on pin A9, OE#, WP#/ACC, and RESET# is +12.5 V which may overshoot to +14.0 V for periods up to 20 ns.
3. No more than one output may be shorted to ground at a time. Duration of the short circuit should not be greater than one second.

Stresses above those listed under "Absolute Maximum Ratings" may cause permanent damage to the device. This is a stress rating only; functional operation of the device at these or any other conditions above those indicated in the operational sections of this data sheet is not implied. Exposure of the device to absolute maximum rating conditions for extended periods may affect device reliability.

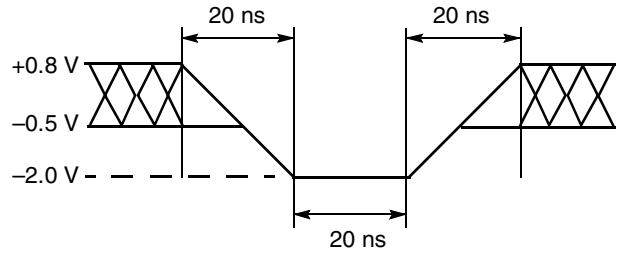

Figure 10. Maximum Negative Overshoot Waveform

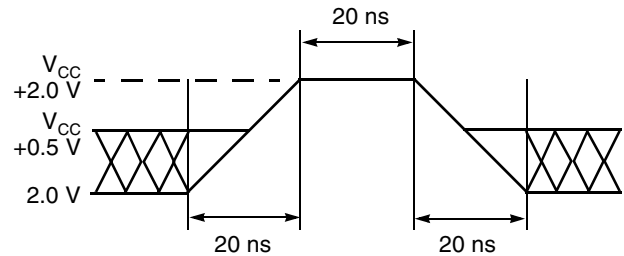

Figure 11. Maximum Positive Overshoot Waveform

OPERATING RANGES

Industrial (I) Devices

Ambient Temperature (T_A)	-40°C to +85°C
---	----------------

Supply Voltages

V_{CC}	3.0–3.6 V
V_{IO} (Note 5)	1.65–3.6 V

4. Operating ranges define those limits between which the functionality of the device is guaranteed.
5. See ordering information for valid VCC/VIO combinations. The I/Os will not operate at 3 V when $V_{IO} = 1.8$ V

DC CHARACTERISTICS

CMOS Compatible

Parameter Symbol	Parameter Description (Notes)	Test Conditions	Min	Typ	Max	Unit
I_{LI}	Input Load Current (1)	$V_{IN} = V_{SS}$ to V_{CC} , $V_{CC} = V_{CC\ max}$			± 2.0	μA
I_{LIT}	A9, ACC Input Load Current	$V_{CC} = V_{CC\ max}$; A9 = 12.5 V			70	μA
I_{LO}	Output Leakage Current	$V_{OUT} = V_{SS}$ to V_{CC} , $V_{CC} = V_{CC\ max}$			± 2.0	μA
I_{CC1}	V_{CC} Active Read Current (2, 3)	CE# = V_{IL} , OE# = V_{IH} ,	1 MHz	6	68	mA
			5 MHz	26	86	
I_{CC2}	V_{CC} Initial Page Read Current (2, 3)	CE# = V_{IL} , OE# = V_{IH}	1 MHz	8	100	mA
			10 MHz	80	160	
I_{CC3}	V_{CC} Intra-Page Read Current (2, 3)	CE# = V_{IL} , OE# = V_{IH}	10 MHz	6	40	mA
			33 MHz	12	80	
I_{CC4}	V_{CC} Active Write Current (3, 4)	CE# = V_{IL} , OE# = V_{IH}		100	120	mA
I_{CC5}	V_{CC} Standby Current (3)	CE#, RESET# = $V_{CC} \pm 0.3$ V, WP# = V_{IH}		2	10	μA
I_{CC6}	V_{CC} Reset Current (3)	RESET# = $V_{SS} \pm 0.3$ V, WP# = V_{IH}		2	10	μA
I_{CC7}	Automatic Sleep Mode (3, 5)	$V_{IH} = V_{CC} \pm 0.3$ V; $V_{IL} = V_{SS} \pm 0.3$ V, WP# = V_{IH}		2	10	μA
V_{IL}	Input Low Voltage		-0.5		0.8	V
V_{IH}	Input High Voltage		1.9		$V_{IO} + 0.3$	V
V_{HH}	Voltage for ACC Program Acceleration	$V_{CC} = 2.7 - 3.6$ V	11.5		12.5	V
V_{ID}	Voltage for Autoselect and Temporary Sector Unprotect	$V_{CC} = 2.7 - 3.6$ V	11.5		12.5	V
V_{OL}	Output Low Voltage	$I_{OL} = 4.0$ mA, $V_{CC} = V_{CC\ min}$			0.4	V
		$I_{OL} = 100$ μA , $V_{CC} = V_{CC\ min}$			0.1	
V_{OH}	Output High Voltage	$I_{OH} = -2.0$ mA, $V_{CC} = V_{CC\ min}$	2.4			V
		$I_{OH} = -100$ μA , $V_{CC} = V_{CC\ min}$	$V_{CC} - 0.1$			
V_{LKO}	Low V_{CC} Lock-Out Voltage (6)		2.3		2.5	V

Notes:

- On the WP#/ACC pin only, the maximum input load current when WP# = V_{IL} is ± 10.0 μA .
- The I_{CC} current listed is typically less than 4 mA/MHz, with OE# at V_{IH} .
- Maximum I_{CC} specifications are tested with $V_{CC} = V_{CC\ max}$.
- I_{CC} active while Embedded Erase or Embedded Program is in progress.
- Automatic sleep mode enables the low power mode when addresses remain stable for $t_{ACC} + 30$ ns.
- Not 100% tested.

TEST CONDITIONS

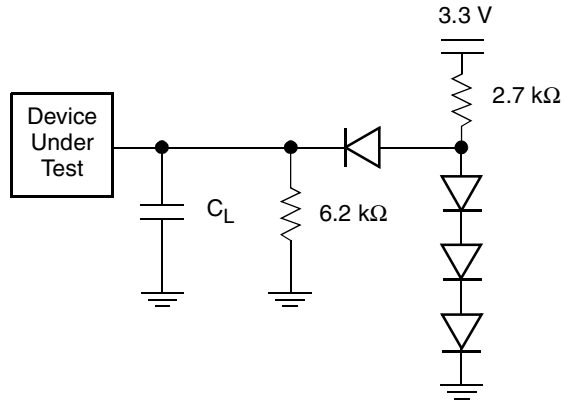

Note: Diodes are IN3064 or equivalent.

Figure 12. Test Setup

Table 13. Test Specifications

Test Condition	All Speeds	Unit
Output Load	1 TTL gate	
Output Load Capacitance, C_L (including jig capacitance)	30	pF
Input Rise and Fall Times	5	ns
Input Pulse Levels	0.0–3.0	V
Input timing measurement reference levels (See Note)	1.5	V
Output timing measurement reference levels	$0.5 V_{IO}$	V

KEY TO SWITCHING WAVEFORMS

WAVEFORM	INPUTS	OUTPUTS
	Steady	
	Changing from H to L	
	Changing from L to H	
	Don't Care, Any Change Permitted	Changing, State Unknown
	Does Not Apply	Center Line is High Impedance State (High Z)

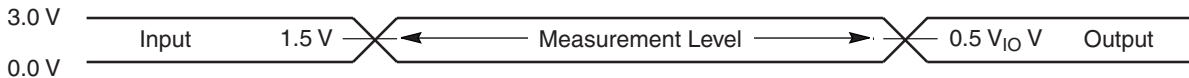

Figure 13. Input Waveforms and Measurement Levels

AC CHARACTERISTICS

Read-Only Operations

Parameter		Description	Test Setup		Speed Options		Unit
JEDEC	Std.				100R	110R	
t_{AVAV}	t_{RC}	Read Cycle Time (Note 1)		Min	100	110	ns
t_{AVQV}	t_{ACC}	Address to Output Delay	CE#, OE# = V_{IL}	Max	100	110	ns
t_{ELQV}	t_{CE}	Chip Enable to Output Delay	OE# = V_{IL}	Max	100	110	ns
	t_{PACC}	Page Access Time		Max	30	30	ns
t_{GLQV}	t_{OE}	Output Enable to Output Delay		Max	30	30	ns
t_{EHQZ}	t_{DF}	Chip Enable to Output High Z (Note 1)		Max	25		ns
t_{GHQZ}	t_{DF}	Output Enable to Output High Z (Note 1)		Max	25		ns
t_{AXQX}	t_{OH}	Output Hold Time From Addresses, CE# or OE#, Whichever Occurs First		Min	0		ns
	t_{OEh}	Output Enable Hold Time (Note 1)	Read	Min	0		ns
			Toggle and Data# Polling	Min	10		ns

Notes:

1. Not 100% tested.
2. See Figure 12 and Table 13 for test specifications.
3. AC Specifications are tested with $V_{IO}=V_{CC}$. Please contact the factory for information on using the device with $V_{IO} \neq V_{CC}$.

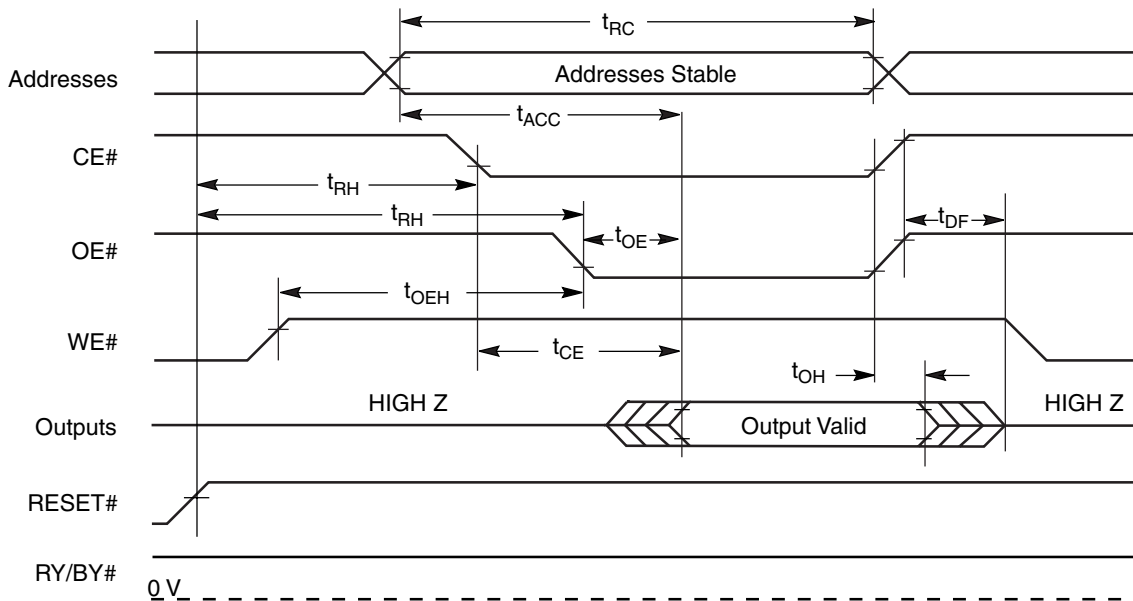
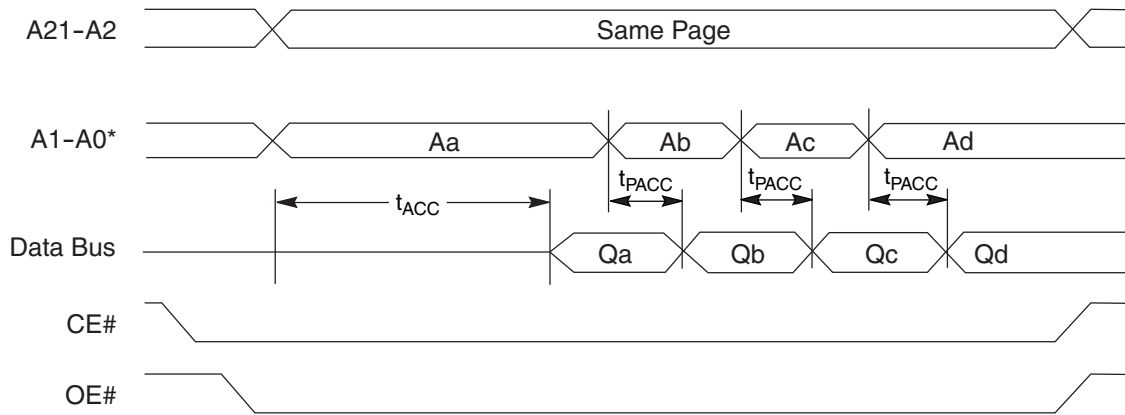

Figure 14. Read Operation Timings

AC CHARACTERISTICS



* Figure shows doubleword mode. Addresses are A1-A-1 for word mode.

Figure 15. Page Read Timings

AC CHARACTERISTICS

Hardware Reset (RESET#)

Parameter		Description		All Speed Options	Unit
JEDEC	Std.				
	t_{Ready}	RESET# Pin Low (During Embedded Algorithms) to Read Mode (See Note)	Max	20	μs
	t_{Ready}	RESET# Pin Low (NOT During Embedded Algorithms) to Read Mode (See Note)	Max	500	ns
	t_{RP}	RESET# Pulse Width	Min	500	ns
	t_{RH}	Reset High Time Before Read (See Note)	Min	50	ns
	t_{RPD}	RESET# Low to Standby Mode	Min	20	μs

1. Not 100% tested
2. AC Specifications are tested with $V_{IO}=V_{CC}$. Please contact the factory for information on using the device with $V_{IO} \neq V_{CC}$.

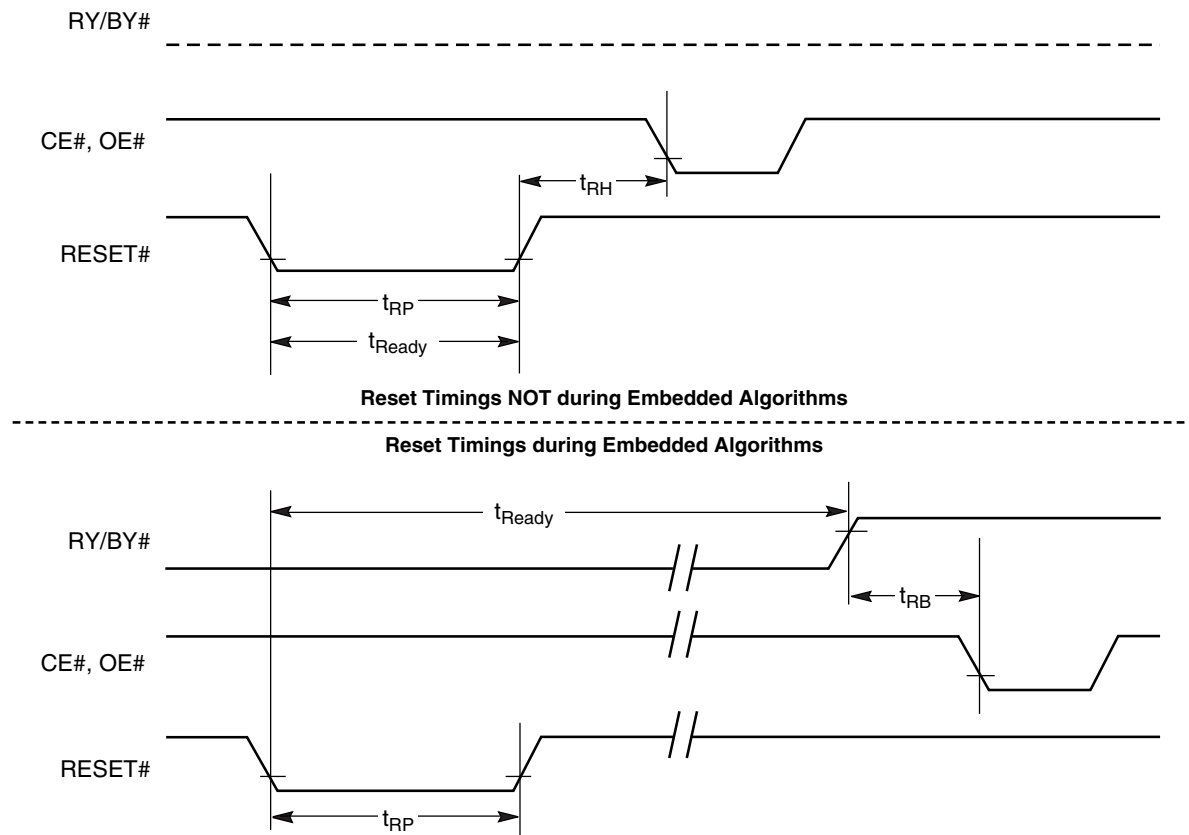

Figure 16. Reset Timings

AC CHARACTERISTICS

Erase and Program Operations

Parameter		Description		Speed Options			
JEDEC	Std.			100R	110R	Unit	
t_{AVAV}	t_{WC}	Write Cycle Time (Note 1)	Min	100	110	ns	
t_{AVWL}	t_{AS}	Address Setup Time	Min	0		ns	
	t_{ASO}	Address Setup Time to OE# low during toggle bit polling	Min	15		ns	
t_{WLAX}	t_{AH}	Address Hold Time	Min	45		ns	
	t_{AHT}	Address Hold Time From CE# or OE# high during toggle bit polling	Min	0		ns	
t_{DVWH}	t_{DS}	Data Setup Time	Min	45		ns	
t_{WHDX}	t_{DH}	Data Hold Time	Min	0		ns	
	t_{OEPH}	Output Enable High during toggle bit polling	Min	20		ns	
t_{GHWL}	t_{GHWL}	Read Recovery Time Before Write (OE# High to WE# Low)	Min	0		ns	
t_{ELWL}	t_{CS}	CE# Setup Time	Min	0		ns	
t_{WHEH}	t_{CH}	CE# Hold Time	Min	0		ns	
t_{WLWH}	t_{WP}	Write Pulse Width	Min	35		ns	
t_{WHDL}	t_{WPH}	Write Pulse Width High	Min	30		ns	
t_{WHWH1}	t_{WHWH1}	Write Buffer Program Operation (Notes 2, 3)	Typ	352		μ s	
		Effective Write Buffer Program Operation (Notes 2, 4)	Per Word	Typ	11		μ s
			Per Doubleword	Typ	22		μ s
		Accelerated Effective Write Buffer Program Operation (Notes 2, 4)	Per Word	Typ	8.8		μ s
			Per Doubleword	Typ	17.6		μ s
		Single Doubleword/Word Program Operation (Note 2)	Word	Typ	100		μ s
			Doubleword	Typ	100		μ s
Accelerated Single Doubleword/Word Programming Operation (Note 2)	Word	Typ	90		μ s		
	Doubleword	Typ	90		μ s		
t_{WHWH2}	t_{WHWH2}	Sector Erase Operation (Note 2)	Typ	0.5		sec	
	t_{VHH}	V_{HH} Rise and Fall Time (Note 1)	Min	250		ns	
	t_{VCS}	V_{CC} Setup Time (Note 1)	Min	50		μ s	

Notes:

1. Not 100% tested.
2. See the "Erase And Programming Performance" section for more information.
3. For 1–16 doublewords/1–32 words programmed.
4. Effective write buffer specification is based upon a 16-doubleword/32-word write buffer operation.
5. AC Specifications are tested with $V_{IO}=V_{CC}$. Please contact the factory for information on using the device with $V_{IO} \neq V_{CC}$.

AC CHARACTERISTICS

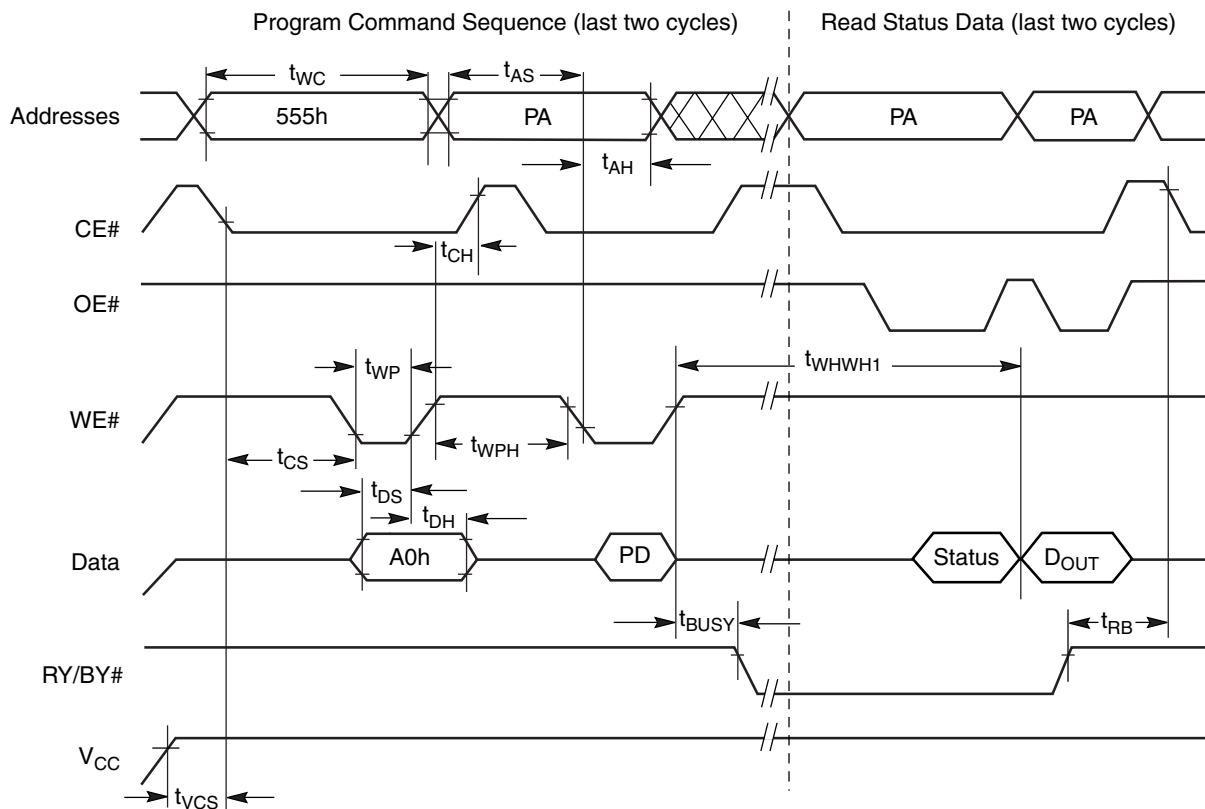

Notes:

1. PA = program address, PD = program data, D_{OUT} is the true data at the program address.
2. Illustration shows device in word mode.

Figure 17. Program Operation Timings

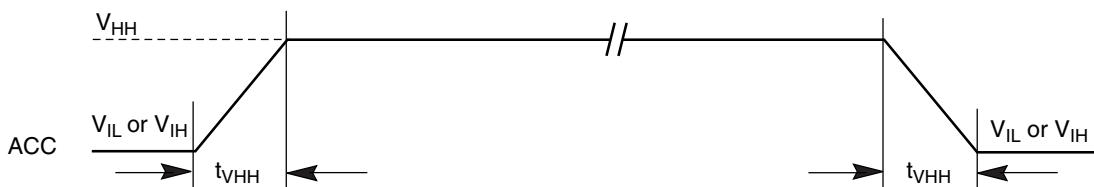
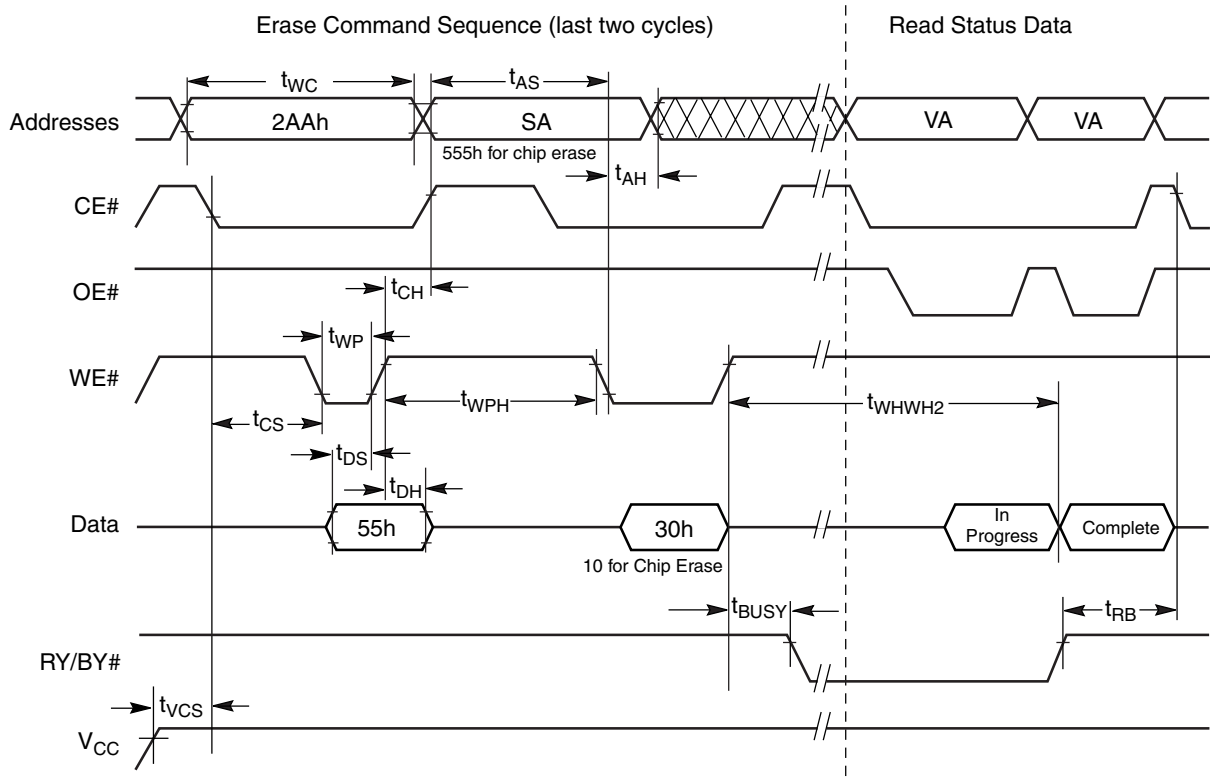

Figure 18. Accelerated Program Timing Diagram

AC CHARACTERISTICS



Notes:

1. SA = sector address (for Sector Erase), VA = Valid Address for reading status data (see "Write Operation Status").
2. These waveforms are for the doubleword mode.

Figure 19. Chip/Sector Erase Operation Timings

AC CHARACTERISTICS

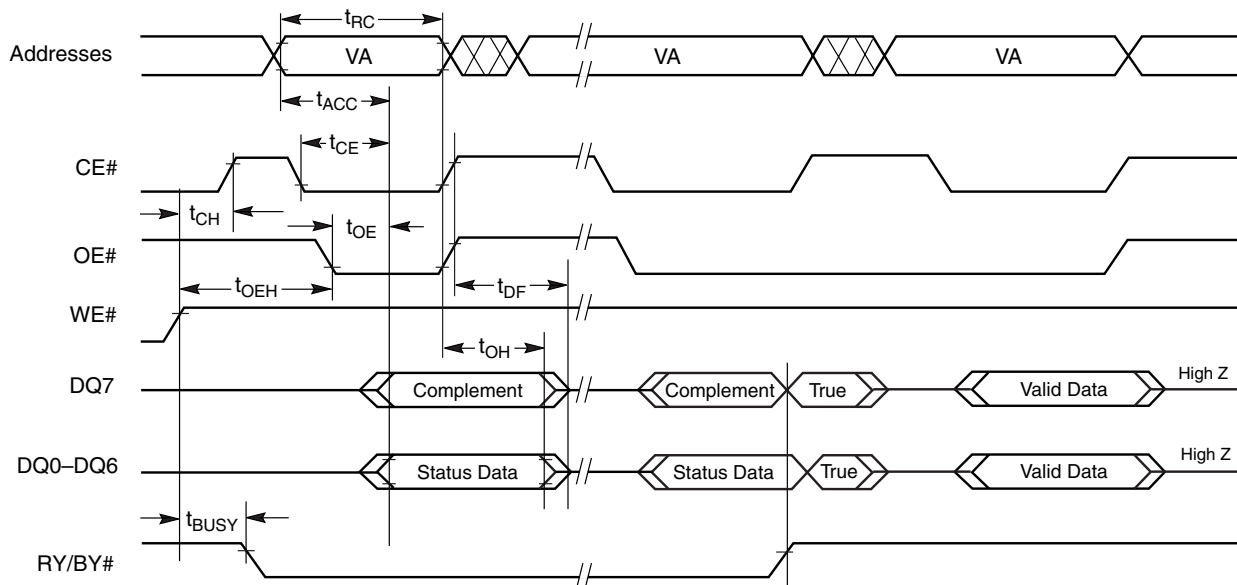

Note: VA = Valid address. Illustration shows first status cycle after command sequence, last status read cycle, and array data read cycle.

Figure 20. Data# Polling Timings (During Embedded Algorithms)

AC CHARACTERISTICS

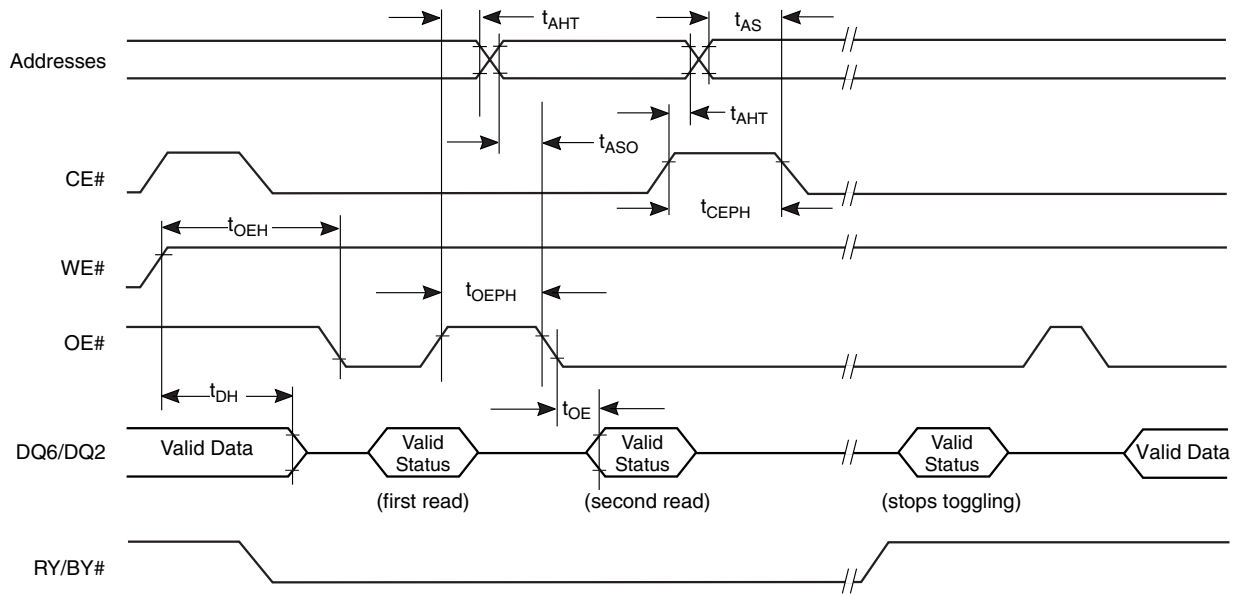

Note: VA = Valid address; not required for DQ6 and DQ14. Illustration shows first two status cycle after command sequence, last status read cycle, and array data read cycle

Figure 21. Toggle Bit Timings (During Embedded Algorithms)

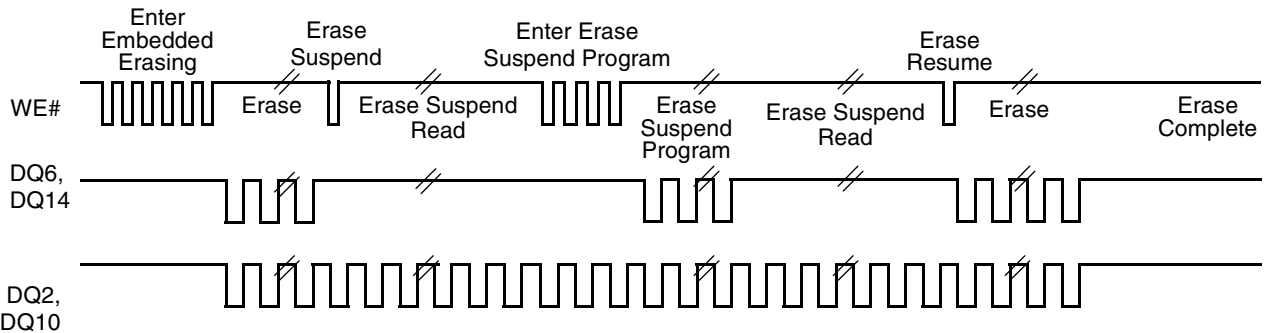

Note: DQ2 and DQ10 toggle only when read at an address within an erase-suspended sector. The system may use OE# or CE# to toggle DQ2 and DQ1- and DQ6 and DQ14.

Figure 22. DQ2 vs. DQ6

AC CHARACTERISTICS

Temporary Sector Unprotect

Parameter		Description		All Speed Options	Unit
JEDEC	Std				
	t_{VIDR}	V_{ID} Rise and Fall Time (See Note)	Min	500	ns
	t_{RSP}	RESET# Setup Time for Temporary Sector Unprotect	Min	4	μ s

1. Not 100% tested.
2. AC Specifications are tested with $V_{IO}=V_{CC}$. Please contact the factory for information on using the device with $V_{IO} \neq V_{CC}$.

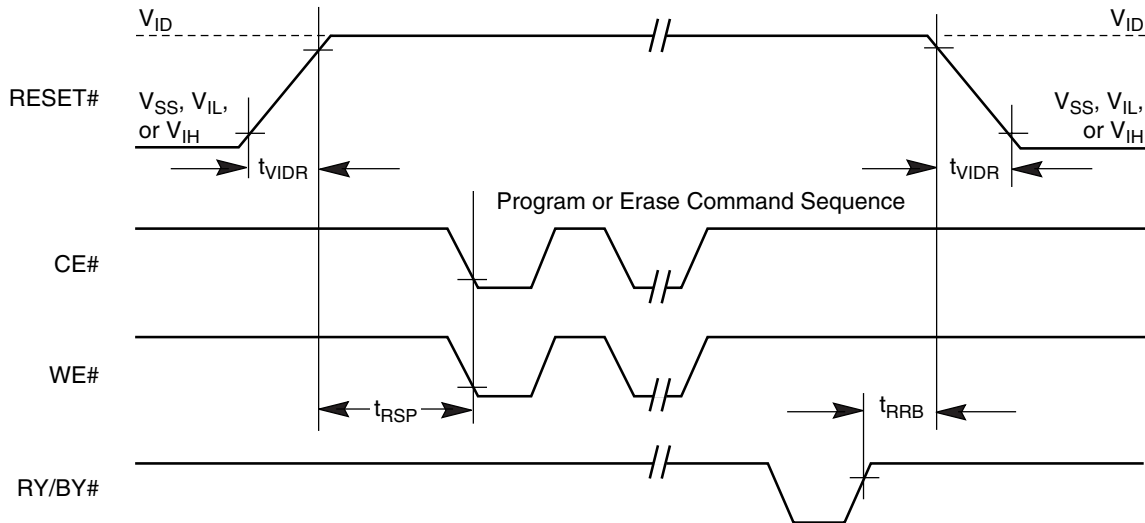
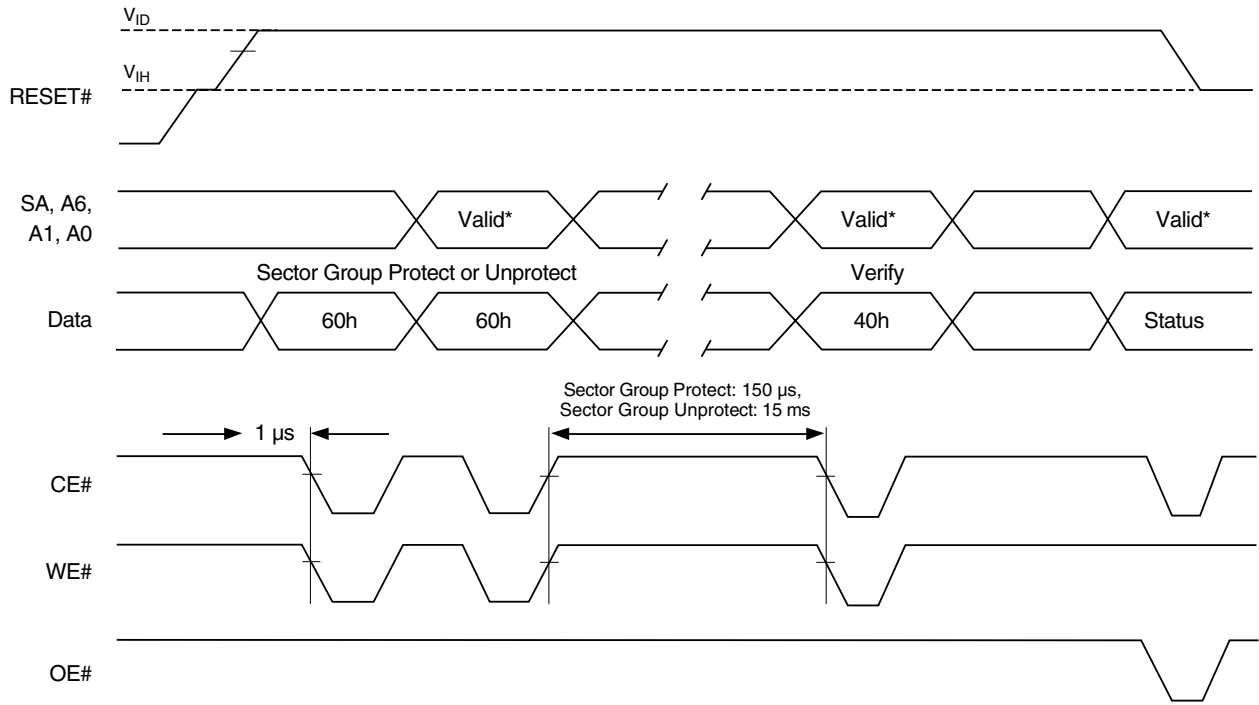

Figure 23. Temporary Sector Group Unprotect Timing Diagram

AC CHARACTERISTICS



* For sector group protect, A6 = 0, A1 = 1, A0 = 0. For sector group unprotect, A6 = 1, A1 = 1, A0 = 0.

Figure 24. Sector Group Protect and Unprotect Timing Diagram

AC CHARACTERISTICS

Alternate CE# Controlled Erase and Program Operations

Parameter		Description		Speed Options			
JEDEC	Std.			100R	110R	Unit	
t_{AVAV}	t_{WC}	Write Cycle Time (Note 1)	Min	100	110	ns	
t_{AVWL}	t_{AS}	Address Setup Time	Min	0		ns	
t_{ELAX}	t_{AH}	Address Hold Time	Min	45		ns	
t_{DVEH}	t_{DS}	Data Setup Time	Min	45		ns	
t_{EHDx}	t_{DH}	Data Hold Time	Min	0		ns	
t_{GHLEL}	t_{GHLEL}	Read Recovery Time Before Write (OE# High to WE# Low)	Min	0		ns	
t_{WLEL}	t_{WS}	WE# Setup Time	Min	0		ns	
t_{EHWH}	t_{WH}	WE# Hold Time	Min	0		ns	
t_{ELEH}	t_{CP}	CE# Pulse Width	Min	45		ns	
t_{EHEL}	t_{CPH}	CE# Pulse Width High	Min	30		ns	
t_{WHWH1}	t_{WHWH1}	Write Buffer Program Operation (Notes 2, 3)	Typ	352		μ s	
		Effective Write Buffer Program Operation (Notes 2, 4)	Per Word	Typ	11		μ s
			Per Doubleword	Typ	22		μ s
		Effective Accelerated Write Buffer Program Operation (Notes 2, 4)	Per Word	Typ	8.8		μ s
			Per Doubleword	Typ	17.6		μ s
		Single Doubleword/Word Program Operation (Note 2)	Word	Typ	100		μ s
			Doubleword	Typ	100		μ s
Accelerated Single Doubleword/Word Programming Operation (Note 2)	Word	Typ	90		μ s		
	Doubleword	Typ	90		μ s		
t_{WHWH2}	t_{WHWH2}	Sector Erase Operation (Note 2)	Typ	0.5		sec	

Notes:

1. Not 100% tested.
2. See the "Erase And Programming Performance" section for more information.
3. For 1–16 doublewords/1–32 words programmed.
4. Effective write buffer specification is based upon a 16-doubleword/32-word write buffer operation.
5. AC Specifications are tested with $V_{IO}=V_{CC}$. Please contact the factory for information on using the device with $V_{IO} \neq V_{CC}$.

AC CHARACTERISTICS

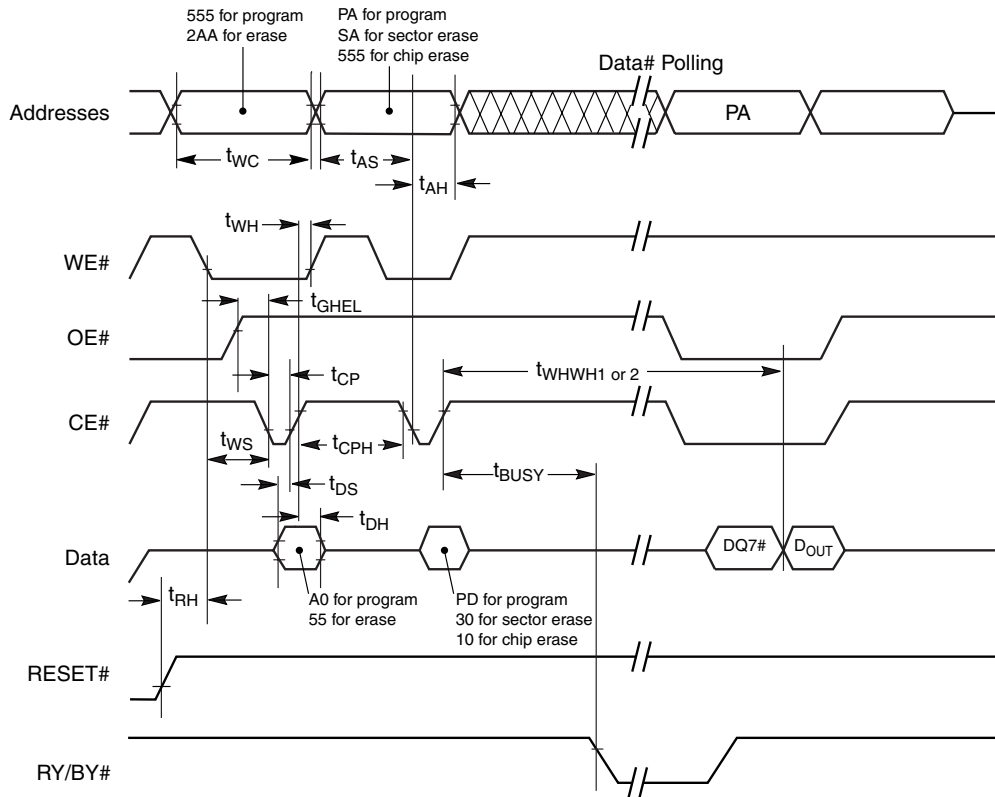

Notes:

1. Figure indicates last two bus cycles of a program or erase operation.
2. PA = program address, SA = sector address, PD = program data.
3. DQ7# and DQ15# are the complement of the data written to the device. D_{OUT} is the data written to the device.
4. Waveforms are for the word mode.

Figure 25. Alternate CE# Controlled Write (Erase/Program) Operation Timings

LATCHUP CHARACTERISTICS

Description	Min	Max
Input voltage with respect to V _{SS} on all pins except I/O pins (including A9, OE#, and RESET#)	-1.0 V	12.5 V
Input voltage with respect to V _{SS} on all I/O pins	-1.0 V	V _{CC} + 1.0 V
V _{CC} Current	-100 mA	+100 mA

Includes all pins except V_{CC}. Test conditions: V_{CC} = 3.0 V, one pin at a time.

ERASE AND PROGRAMMING PERFORMANCE

Parameter		Typ (Note 1)	Max (Note 2)	Unit	Comments
Sector Erase Time		0.5	15	sec	Excludes 00h programming prior to erasure (Note 5)
Chip Erase Time		32	128	sec	
Single Doubleword/Word Program Time (Note 3)	Word	100	TBD	μs	Excludes system level overhead (Note 6)
	Doubleword	100	TBD	μs	
Accelerated Single Doubleword/Word Program Time	Word	90	TBD	μs	
	Doubleword	90	TBD	μs	
Total Write Buffer Program Time (Note 4)		352	TBD	μs	
Effective Write Buffer Program Time (Note 3)	Per Word	11	TBD	μs	
	Per Doubleword	22	TBD	μs	
Total Accelerated Write Buffer Program Time (Note 4)		282	TBD	μs	
Effective Write Buffer Accelerated Program Time (Note 3)	Per Word	8.8	TBD	μs	
	Per Doubleword	17.6	TBD	μs	
Chip Program Time		92	TBD	sec	

Notes:

1. Typical program and erase times assume the following conditions: 25°C, 3.0 V V_{CC} , 10,000 cycles. Additionally, programming typicals assume checkerboard pattern.
2. Under worst case conditions of 90°C, $V_{CC} = 3.0$ V, 100,000 cycles.
3. Effective write buffer specification is based upon a 16-doubleword/32-word write buffer operation.
4. For 1–16 doublewords or 1-32 words programmed in a single write buffer programming operation.
5. In the pre-programming step of the Embedded Erase algorithm, all bits are programmed to 00h before erasure.
6. System-level overhead is the time required to execute the two- or four-bus-cycle sequence for the program command. See Tables 10 and 11 for further information on command definitions.

TSOP PIN AND BGA PACKAGE CAPACITANCE

Parameter Symbol	Parameter Description	Test Setup		Typ	Max	Unit
C_{IN}	Input Capacitance	$V_{IN} = 0$	BGA	TBD	TBD	pF
C_{OUT}	Output Capacitance	$V_{OUT} = 0$	BGA	TBD	TBD	pF
C_{IN2}	Control Pin Capacitance	$V_{IN} = 0$	BGA	TBD	TBD	pF

Notes:

1. Sampled, not 100% tested.
2. Test conditions $T_A = 25^\circ\text{C}$, $f = 1.0$ MHz.

DATA RETENTION

Parameter Description	Test Conditions	Min	Unit
Minimum Pattern Data Retention Time	150°C	10	Years
	125°C	20	Years

PHYSICAL DIMENSIONS

LSB080—80-Ball Fortified Ball Grid Array (Fortified BGA)
13 x 11 mm Package

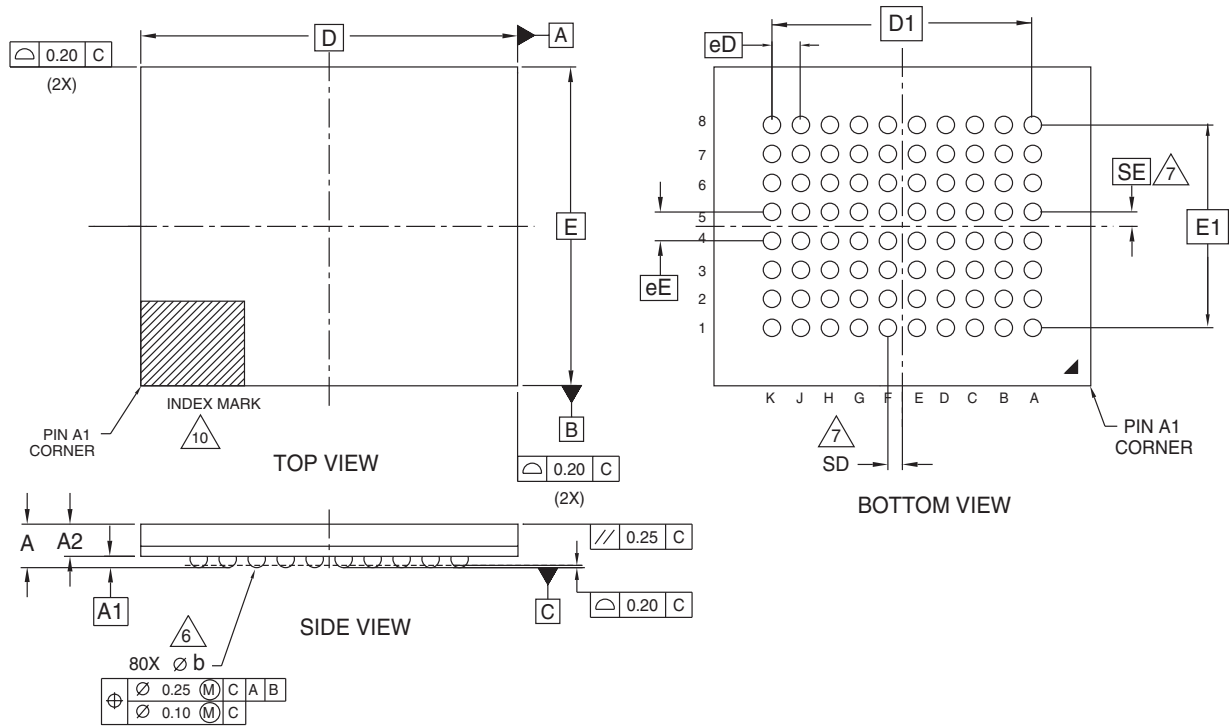

PACKAGE	LSB 080			
JEDEC	N/A			
D x E	13.00 mm x 11.00 mm PACKAGE			
SYMBOL	MIN	NOM	MAX	NOTE
A	---	---	1.60	PROFILE
A1	0.40	---	---	BALL HEIGHT
A2	1.00	---	1.11	BODY THICKNESS
D	13.00 BSC.			BODY SIZE
E	11.00 BSC.			BODY SIZE
D1	9.00 BSC.			MATRIX FOOTPRINT
E1	7.00 BSC.			MATRIX FOOTPRINT
MD	10			MATRIX SIZE D DIRECTION
ME	8			MATRIX SIZE E DIRECTION
n	80			BALL COUNT
øb	0.50	0.60	0.70	BALL DIAMETER
eE	1.00 BSC.			BALL PITCH
eD	1.00 BSC.			BALL PITCH
SD / SE	0.50 BSC.			SOLDER BALL PLACEMENT
				DEPOPULATED SOLDER BALLS

NOTES:

- DIMENSIONING AND TOLERANCING METHODS PER ASME Y14.5M-1994.
- ALL DIMENSIONS ARE IN MILLIMETERS.
- BALL POSITION DESIGNATION PER JESD 95-1, SPP-010.
- eE REPRESENTS THE SOLDER BALL GRID PITCH.
- SYMBOL "MD" IS THE BALL MATRIX SIZE IN THE "D" DIRECTION.
SYMBOL "ME" IS THE BALL MATRIX SIZE IN THE "E" DIRECTION.
n IS THE NUMBER OF POPULATED SOLDER BALL POSITIONS FOR MATRIX SIZE MD X ME.
- $\triangle 6$ DIMENSION "b" IS MEASURED AT THE MAXIMUM BALL DIAMETER IN A PLANE PARALLEL TO DATUM C.
- $\triangle 7$ SD AND SE ARE MEASURED WITH RESPECT TO DATUMS A AND B AND DEFINE THE POSITION OF THE CENTER SOLDER BALL IN THE OUTER ROW.
WHEN THERE IS AN ODD NUMBER OF SOLDER BALLS IN THE OUTER ROW SD OR SE = 0.000.
WHEN THERE IS AN EVEN NUMBER OF SOLDER BALLS IN THE OUTER ROW, SD OR SE = $\frac{e}{2}$
- "+" INDICATES THE THEORETICAL CENTER OF DEPOPULATED BALLS.
- N/A
- $\triangle 10$ A1 CORNER TO BE IDENTIFIED BY CHAMFER, LASER OR INK MARK, METALLIZED MARK INDENTATION OR OTHER MEANS.

3265 \ 16-038.15a

REVISION SUMMARY

Revision A (January 20, 2003)

Initial release.

Revision B (September 17, 2003)

Global

Changed data sheet status from Advance Information to Preliminary.

Distinctive Characteristics

Changed description of device erase cycle endurance. Changed typical sector erase time, typical write buffer programming time, and typical active read current specification.

Customer Lockable: SecSi Sector NOT Programmed or Protected at the factory.

Added second bullet, SecSi sector-protect verify text and figure 3.

Erase Suspend/Erase Resume Commands

Deleted reference to erase-suspended sector address requirement for commands.

Tables 10 and 11, Command Definitions

Corrected addresses for Erase Suspend and Erase Resume to "XXX" (don't care).

DC Characteristics

Changed typical and maximum values for I_{CC1} , I_{CC2} , and I_{CC3} . Values for different frequencies were added to I_{CC2} and I_{CC3} .

AC Characteristics

Erase and Program Operations table; Alternate CE# Controlled Erase and Program Operations table. Changed values for the following parameters: Write Buffer Program Operation, Effective Write Buffer Program Operation, Accelerated Effective Write Buffer Program Operation, Sector Erase Operation, Single Doubleword/Word Program Operation, Accelerated Single Doubleword/Word Program Operation (the phrase "Single Doubleword/Word" was added to the last two parameter titles).

Erase and Programming Performance

Changed typical sector erase time. Changed typical chip erase time and added maximum erase time. Replaced TBDs for all typical specifications with actual values. Added phrase "Single Doubleword/Word" to Program Time and Accelerated Program Time parameters titles. Added Total Write Buffer Program Time and Total Accelerated Write Buffer Program Time parameters to table. Changed device endurance in Note 1 to 10,000 cycles. Changed write buffer operation size in Note 3. Note 4 now refers to write buffer programming instead of chip programming. Deleted Note 7.

Trademarks

Copyright © 2003 Advanced Micro Devices, Inc. All rights reserved.

AMD, the AMD logo, and combinations thereof are registered trademarks of Advanced Micro Devices, Inc.

ExpressFlash is a trademark of Advanced Micro Devices, Inc.

Product names used in this publication are for identification purposes only and may be trademarks of their respective companies.

Sales Offices and Representatives

North America

ALABAMA	(256) 830-9192	Irvine - Centaur.....	(949) 261-2123
ARIZONA	(602) 242-4400	San Diego - Centaur.....	(858) 278-4950
CALIFORNIA,		Santa Clara - Fourfront	(408) 350-4800
West Lake Village	(805) 496-3992	CANADA,	
Irvine	(949) 450-7500	Burnaby, B.C. - Davetek Marketing	(604) 430-3680
Los Angeles.....	(805) 496-3992	Calgary, Alberta - Davetek Marketing.....	(403) 283-3577
Pleasanton	(925) 416-8150	Kanata, Ontario - J-Squared Tech.....	(613) 592-9540
Sacramento (Cool)	(530) 886-0945	Mississauga, Ontario - J-Squared Tech.....	(905) 672-2030
San Diego	(858) 566-6414	St Laurent, Quebec - J-Squared Tech.....	(514) 747-1211
San Jose	(408) 922-0300	COLORADO,	
CANADA (Toronto).....	(905) 831-6226	Golden - Compass Marketing	(303) 277-0456
COLORADO	(303) 741-2900	FLORIDA,	
CONNECTICUT.....	(203) 264-7800	Melbourne - Marathon Technical Sales.....	(321) 728-7706
FLORIDA,		Ft. Lauderdale - Marathon Technical Sales	(954) 527-4949
Clearwater.....	(727) 793-0055	Orlando - Marathon Technical Sales.....	(407) 872-5775
Miami (Lakes).....	(305) 820-1113	St. Petersburg - Marathon Technical Sales.....	(727) 894-3603
GEORGIA	(770) 814-0224	GEORGIA,	
ILLINOIS,		Duluth - Quantum Marketing	(678) 584-1128
Chicago	(630) 773-4422	ILLINOIS,	
Mundelein.....	(847) 837-0439	Skokie - Industrial Reps, Inc.	(847) 967-8430
MASSACHUSETTS	(781) 213-6400	INDIANA,	
MICHIGAN	(248) 471-6294	Kokomo - SAI	(765) 457-7241
MINNESOTA	(612) 745-0005	IOWA,	
NEW JERSEY,		Cedar Rapids - Lorenz Sales	(319) 294-1000
Chatham.....	(973) 701-1777	KANSAS,	
Cherry Hill	(856) 662-2900	Lenexa - Lorenz Sales	(913) 469-1312
Parsippany	(973) 299-0002	MASSACHUSETTS,	
NEW YORK	(716) 425-8050	Burlington - Synergy Associates	(781) 238-0870
NORTH CAROLINA	(919) 840-8080	MICHIGAN,	
OREGON.....	(503) 245-0080	Brighton - SAI	(810) 227-0007
PENNSYLVANIA	(215) 340-1187	MINNESOTA,	
SOUTH DAKOTA.....	(605) 692-5777	St. Paul - Cahill, Schmitz & Cahill, Inc.	(651) 699-0200
TEXAS,		MISSOURI,	
Austin	(512) 346-7830	St. Louis - Lorenz Sales	(314) 997-4558
Dallas	(972) 985-1344	NEW JERSEY,	
Houston.....	(281) 376-8084	Mt. Laurel - SJ Associates	(856) 866-1234
VIRGINIA	(703) 736-9568	NEW YORK,	

International

AUSTRALIA, North Ryde	TEL	(61) 2-88-777-222	
BELGIUM, Antwerpen	TEL	(32) 3-2-48-43-00	
BRAZIL, San Paulo	TEL	(55) 11-5501-2105	
CHINA,			
Beijing.....	TEL	(86) 10-6510-2188	
Shanghai.....	TEL	(86) 21-635-00838	
Shenzhen.....	TEL	(86) 755-246-1550	
FINLAND, Helsinki	TEL	(358) 881-3117	
FRANCE, Paris	TEL	(33)-1-49-75-1010	
GERMANY,			
Bad Homburg	TEL	(49)-6172-92670	
Munich.....	TEL	(49)-89-450530	
HONG KONG, Causeway Bay	TEL	(85) 2-2956-0388	
ITALY, Milan	TEL	(39)-2-381961	
INDIA, New Delhi	TEL	(91) 11-623-8620	
JAPAN,			
Osaka	TEL	(81) 6-6243-3250	
Tokyo	TEL	(81) 3-3346-7600	
KOREA, Seoul.....	TEL	(82) 2-3468-2600	
SINGAPORE, Singapore.....	TEL	(65) 6-337-7-033	
SWITZERLAND, Geneva	TEL	(41) 22-788-0251	
SWEDEN, Stockholm	TEL	(46) 8-562-5-40-00	
TAIWAN, Taipei.....	TEL	(886) 2-8773-1555	
UNITED KINGDOM,			
Frimley	TEL	(44) 1276-803100	
Haydock	TEL	(44) 1942-272888	
Irvine - Centaur.....	(949) 261-2123	Buffalo - Nycorn, Inc.	(716) 741-7116
San Diego - Centaur.....	(858) 278-4950	East Syracuse - Nycorn, Inc.....	(315) 437-8343
Santa Clara - Fourfront	(408) 350-4800	Pittsford - Nycorn, Inc.....	(716) 586-3660
Burnaby, B.C. - Davetek Marketing	(604) 430-3680	Rockville Centre - SJ Associates	(516) 536-4242
Calgary, Alberta - Davetek Marketing.....	(403) 283-3577	NORTH CAROLINA,	
Kanata, Ontario - J-Squared Tech.....	(613) 592-9540	Raleigh - Quantum Marketing	(919) 846-5728
Mississauga, Ontario - J-Squared Tech.....	(905) 672-2030	OHIO,	
St Laurent, Quebec - J-Squared Tech.....	(514) 747-1211	Middleburg Hts - Dolfuss Root & Co.....	(440) 816-1660
Golden - Compass Marketing	(303) 277-0456	Powell - Dolfuss Root & Co.	(614) 781-0725
Melbourne - Marathon Technical Sales.....	(321) 728-7706	Vandalia - Dolfuss Root & Co.	(937) 898-9610
Ft. Lauderdale - Marathon Technical Sales	(954) 527-4949	Westerville - Dolfuss Root & Co.....	(614) 523-1990
Orlando - Marathon Technical Sales.....	(407) 872-5775	OREGON,	
St. Petersburg - Marathon Technical Sales.....	(727) 894-3603	Lake Oswego - I Squared, Inc.	(503) 670-0557
Duluth - Quantum Marketing	(678) 584-1128	UTAH,	
Skokie - Industrial Reps, Inc.	(847) 967-8430	Murray - Front Range Marketing.....	(801) 288-2500
Kokomo - SAI	(765) 457-7241	VIRGINIA,	
Cedar Rapids - Lorenz Sales	(319) 294-1000	Glen Burnie - Coherent Solution, Inc.	(410) 761-2255
Lenexa - Lorenz Sales	(913) 469-1312	WASHINGTON,	
Burlington - Synergy Associates	(781) 238-0870	Kirkland - I Squared, Inc.....	(425) 822-9220
Brighton - SAI	(810) 227-0007	WISCONSIN,	
St. Paul - Cahill, Schmitz & Cahill, Inc.	(651) 699-0200	Pewaukee - Industrial Representatives.....	(262) 574-9393
St. Louis - Lorenz Sales	(314) 997-4558	Capital Federal. Argentina- Latin/WW Rep	(+54-11) 4373-0655
Mt. Laurel - SJ Associates	(856) 866-1234	CHILE,	
Buffalo - Nycorn, Inc.	(716) 741-7116	Santiago - LatinRep/WWRep	(+562) 264-0993
East Syracuse - Nycorn, Inc.....	(315) 437-8343	COLUMBIA,	
Pittsford - Nycorn, Inc.....	(716) 586-3660	Bogota - Dimser.....	(571) 410-4182
Rockville Centre - SJ Associates	(516) 536-4242	MEXICO,	
Raleigh - Quantum Marketing	(919) 846-5728	Guadalajara - LatinRep/WW Rep.....	(523) 817-3900
Middleburg Hts - Dolfuss Root & Co.....	(440) 816-1660	Mexico, City - LatinRep/WW Rep.....	(525) 752-2727
Powell - Dolfuss Root & Co.	(614) 781-0725	Monterrey - LatinRep/WW Rep	(528) 369-6828
Vandalia - Dolfuss Root & Co.	(937) 898-9610	PUERTO RICO,	
Westerville - Dolfuss Root & Co.....	(614) 523-1990	Boqueron - Infinitronics	(787) 851-6000
Lake Oswego - I Squared, Inc.	(503) 670-0557		
Murray - Front Range Marketing.....	(801) 288-2500		
Glen Burnie - Coherent Solution, Inc.	(410) 761-2255		
Kirkland - I Squared, Inc.....	(425) 822-9220		
Pewaukee - Industrial Representatives.....	(262) 574-9393		

Representatives in Latin America

Representatives in U.S. and Canada

ARIZONA,	
Tempe - Centaur	(480) 839-2320
CALIFORNIA,	
Calabasas - Centaur	(818) 878-5800

Advanced Micro Devices reserves the right to make changes in its product without notice in order to improve design or performance characteristics. The performance characteristics listed in this document are guaranteed by specific tests, guard banding, design and other practices common to the industry. For specific testing details, contact your local AMD sales representative. The company assumes no responsibility for the use of any circuits described herein.



One AMD Place, P.O. Box 3453, Sunnyvale, CA 94088-3453 408-732-2400
 TWX 910-339-9280 TELEX 34-6306 800-538-8450 <http://www.amd.com>

© 2002 Advanced Micro Devices, Inc.

Printed in USA