

Dual 1A Low Dropout Positive Regulator

■ Features

- 1.3V maximum dropout at full load current
- Fast transient response
- Output current limiting for each channel.
- Built-in thermal shutdown each channel.
- Good noise rejection
- Dual output ch1=3.3V, ch2=2.5V
(1.8V for B version)
- Packages: SOP-8L

■ Applications

- PC peripheral
- Communication

■ General Description

AP1120 series are low dropout positive regulator with minimum of 1A output current capability. The product is specifically designed to provide well-regulated supply for low voltage IC applications such as high-speed bus termination and low current 3.3V/2.5V or 3.3V/1.8V logic supply. AP1120 series are guaranteed to have <1.3V dropout at full load current making it ideal to provide well regulated outputs dual channels with up to 18V input supply.

■ Connection Diagram

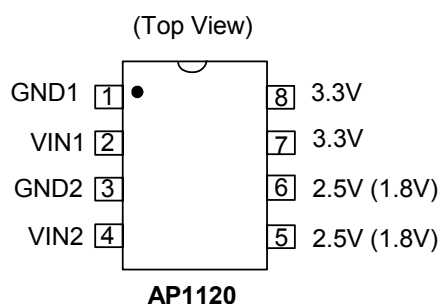

■ Pin Descriptions

NAME	FUNCTION
GND1/2	Ground
3.3V(Vout1)	The output of the regulator. A minimum of 10uF capacitor ($0.15\Omega \leq \text{ESR} \leq 20\Omega$) must be connected from this pin to ground to insure stability.
2.5V/1.8V (Vout2)	The output of the regulator. A minimum of 10uF capacitor ($0.15\Omega \leq \text{ESR} \leq 20\Omega$) must be connected from this pin to ground to insure stability.
VIN1/2	The input pin of regulator. Typically a large storage capacitor ($0.15\Omega \leq \text{ESR} \leq 20\Omega$) is connected from this pin to ground.

■ Ordering Information

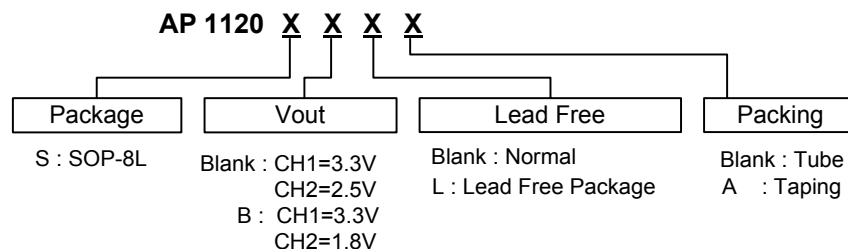

Dual 1A Low Dropout Positive Regulator

■ Typical Circuit

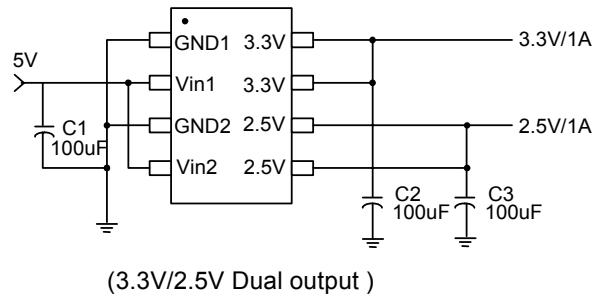

■ Absolute Maximum Ratings

Symbol	Parameter	Rating	Unit
V_{IN}	DC Supply Voltage	-0.3 to 18 V	V
P_D	Power Dissipation	Internally Limited	
T_{ST}	Storage Temperature	-65 to +150	°C
T_{OP}	Operating Junction Temperature Range	0 to +150	°C

■ Block Diagram

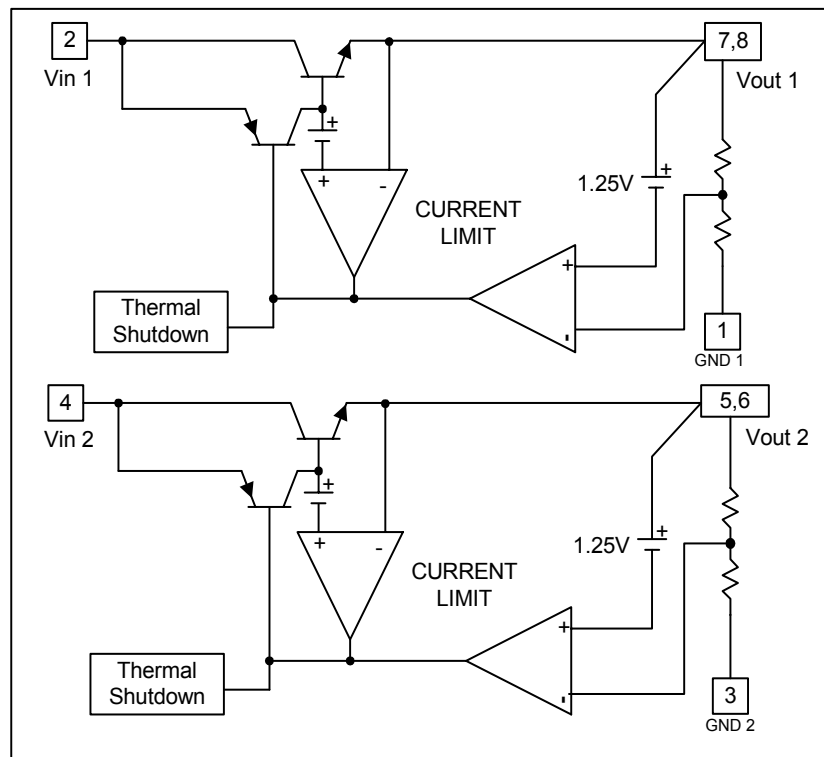



Dual 1A Low Dropout Positive Regulator

■ Electrical Characteristics (Under Operating Conditions)

PARAMETER	CONDITIONS	MIN	TYP	MAX	UNIT	
Output Voltage	AP1120(B) - V_{OUT1}	$I_{OUT} = 10mA, T_J = 25^{\circ}C, 4.8V \leq V_{IN} \leq 12V$	3.235	3.300	3.365	V
	AP1120 - V_{OUT2}	$I_{OUT} = 10mA, T_J = 25^{\circ}C, 4V \leq V_{IN} \leq 12V$	2.450	2.500	2.550	V
	AP1120B - V_{OUT2}	$I_{OUT} = 10mA, T_J = 25^{\circ}C, 4V \leq V_{IN} \leq 12V$	1.764	1.800	1.836	V
Line Regulation	$I_O=10mA, V_{OUT}+1.5V < V_{IN} < 12V, T_J=25^{\circ}C$			0.2	%	
Load Regulation	AP1120 series V_{OUT1}	$V_{IN} = 5V, 0 \leq I_{OUT} \leq 1A, T_J=25^{\circ}C$ (Note 1,2)		26	33	mV
	AP1120 series V_{OUT2}	$V_{IN}=4V, 0mA < I_O < 1A, T_J=25^{\circ}C$ (Note 1,2)		20	25	mV
Dropout Voltage ($V_{IN}-V_{OUT}$)	$I_{OUT} = 1A, \Delta V_{OUT}=0.1\%V_{OUT}$		1.3	1.4	V	
Current Limit	$(V_{IN}-V_{OUT}) = 5V$	1.1			A	
Minimum Load Current	$0^{\circ}C \leq T_J \leq 125^{\circ}C$ (Note 3)		5	10	mA	
Thermal Regulation	$T_A=25^{\circ}C, 30ms$ pulse		0.008	0.04	%/W	
Ripple Rejection	$F=120Hz, C_{OUT}=25\mu F$ Tantalum, $I_{OUT}=1A$		60	70	dB	
Temperature Stability	$I_O=10mA$		0.5		%	
θ_{JA} Thermal Resistance Junction-to-Ambient (No heat sink; No air flow)	SOP8: Control Circuitry/Power Transistor (Note4) CH1 or CH2 only CH1 & CH2 and PD1=PD2		50 45		$^{\circ}C/W$	
θ_{JC} Thermal Resistance Junction-to-Case	SOP8: Control Circuitry/Power Transistor (Note 4) CH1 or CH2 only CH1 & CH2 and PD1=PD2		20 12		$^{\circ}C/W$	

Note1: See thermal regulation specifications for changes in output voltage due to heating effects. Line and load regulation are measured at a constant junction temperature by low duty cycle pulse testing. Load regulation is measured at the output lead = 1/18" from the package.

Note2: Line and load regulation are guaranteed up to the maximum power dissipation of 15W. Power dissipation is determined by the input/output differentially and the output current. Guaranteed maximum power dissipation will not be available over the full input/output range.

Note3: Quiescent current is defined as the minimum output current that requires maintaining regulation. At 12V input/output differential the device is guaranteed to regulate if the output current is greater than 10mA.

Note4: Vout1 and Vout2 are connected to the PCB copper area 5.5mm*5.5mm separately. If you need large PD or lower Tc & Tj, please connect to the large copper area >> 5.5mm*5.5mm (like 10mm*10mm).

Dual 1A Low Dropout Positive Regulator

■ Typical Performance Characteristics

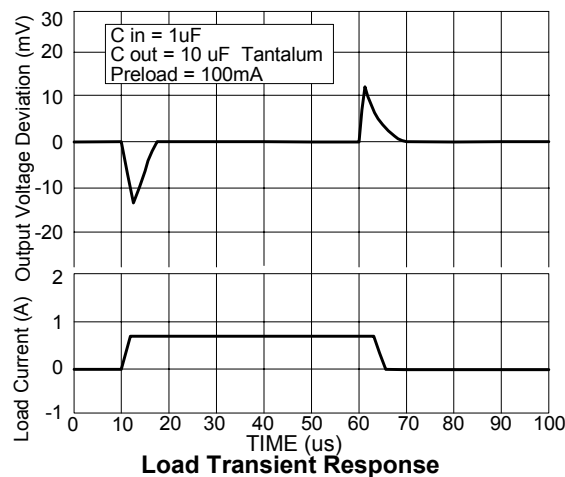
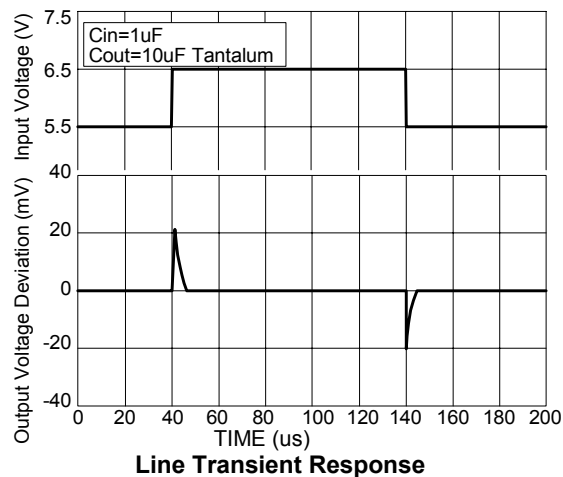
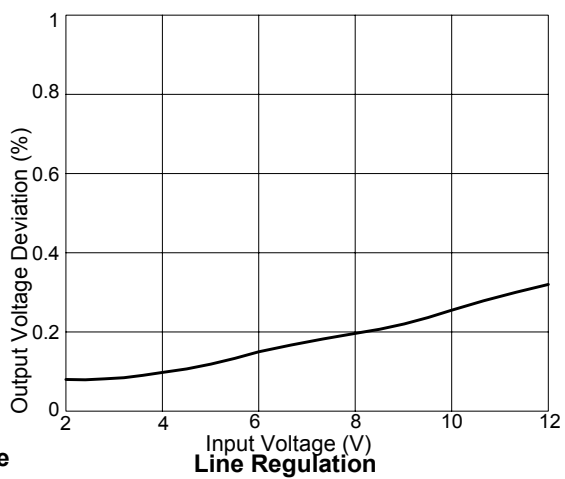
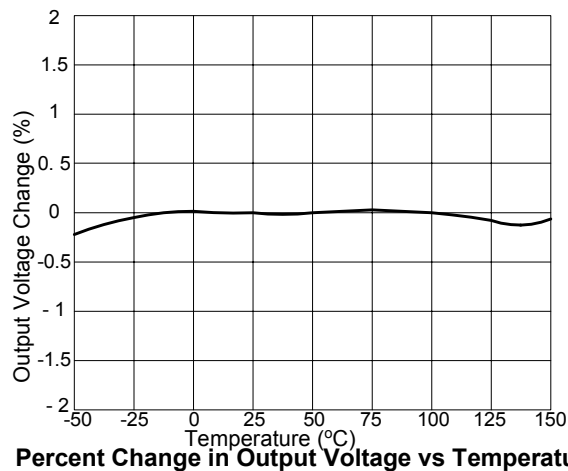
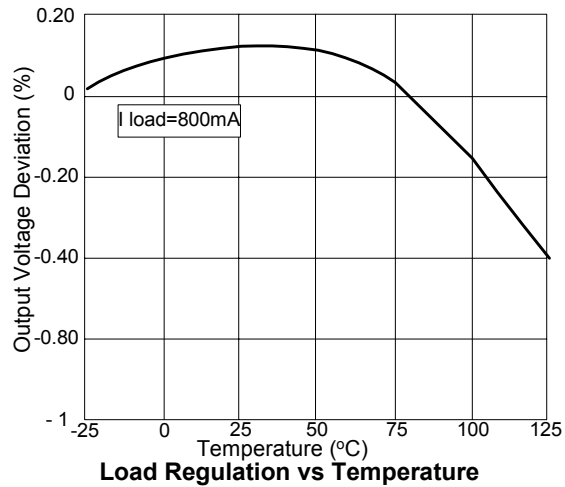
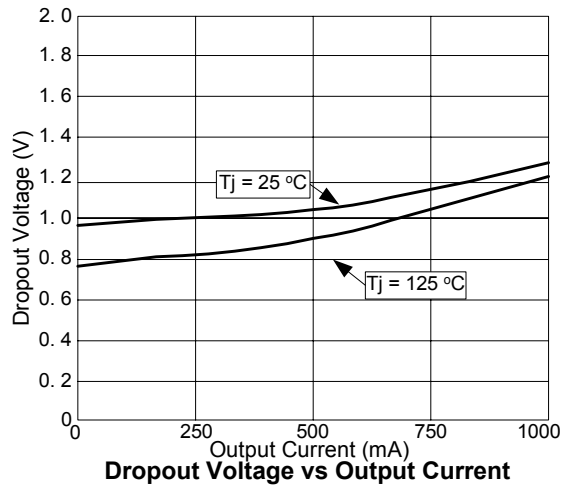

Dual 1A Low Dropout Positive Regulator

■ Marking Information

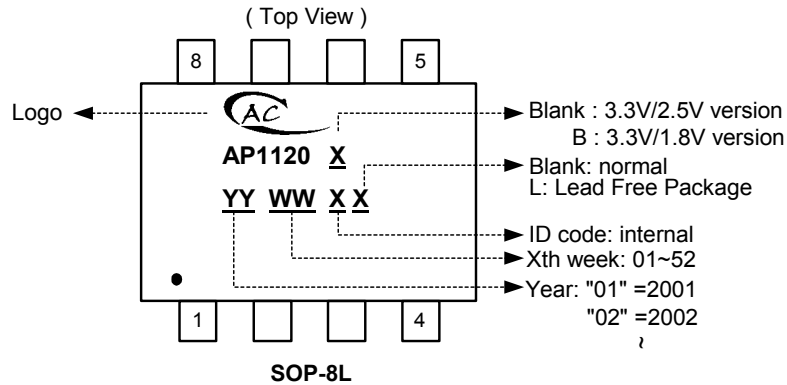

■ Package Information

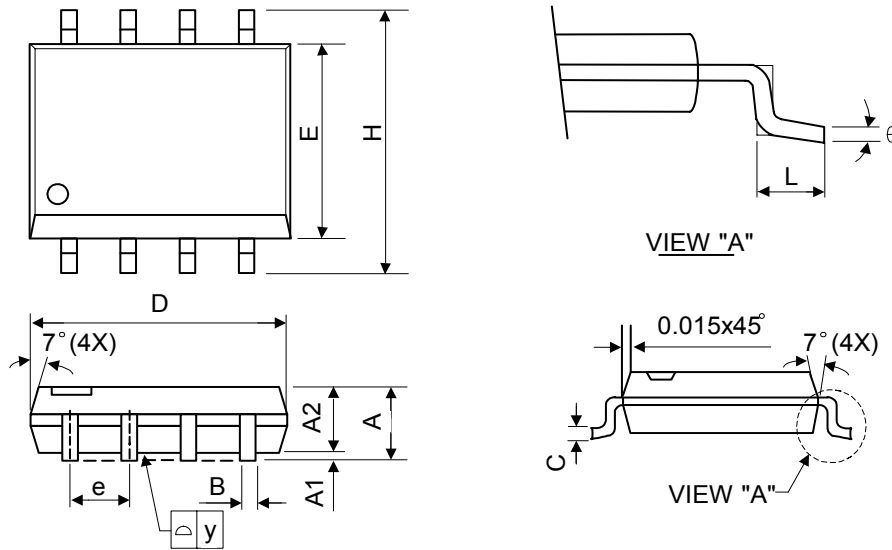

Symbol	Dimensions In Millimeters			Dimensions In Inches		
	Min.	Nom.	Max.	Min.	Nom.	Max.
A	1.40	1.60	1.75	0.055	0.063	0.069
A1	0.10	-	0.25	0.040	-	0.100
A2	1.30	1.45	1.50	0.051	0.057	0.059
B	0.33	0.41	0.51	0.013	0.016	0.020
C	0.19	0.20	0.25	0.0075	0.008	0.010
D	4.80	5.05	5.30	0.189	0.199	0.209
E	3.70	3.90	4.10	0.146	0.154	0.161
e	-	1.27	-	-	0.050	-
H	5.79	5.99	6.20	0.228	0.236	0.244
L	0.38	0.71	1.27	0.015	0.028	0.050
y	-	-	0.10	-	-	0.004
θ	0°	-	8°	0°	-	8°