

500mA Low Dropout Linear Regulator of Adjustable and Fixed Voltages

Features

- Low Dropout Voltage of 1.3V at 500mA
- Output Voltage Accuracy $\pm 2.0\%$
- Line Regulation - 3mV (typ.)
- Load Regulation - 13mV (typ.)
- Input Voltage Range up to 9V
- Internal Current Limiting and Thermal Shutdown Protections
- Available Output Voltages -ADJ, 1.8V, 2.5V, 3.3V
- Various SOT-89 and TO-92 Packages Available

General Description

The APL5885 is a 3-pin low dropout linear regulator with 2.0% accuracy of output voltage over line, load and temperature variations. Dropout voltage at 500mA output current is less than 1.3V. Both output current limiting and thermal shutdown are built in to provide maximal protection to the APL5885 against fault conditions. The over current and thermal shutdown circuits become active when the current exceed 500mA, or the junction temperature reach 150°C. Normal operation is recovered when junction temperature drops below 130°C.

Applications

- Voltage Regulator for CD-ROM Drivers
- Voltage Regulator for LAN Cards
- Wireless Communication Systems
- Portable Instrument
- Portable Consumer Equipment
- Low Voltage Systems

Pin Configuration

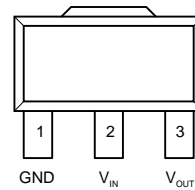

SOT-89 (Top View)

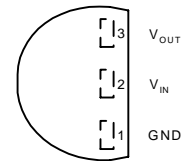

TO-92 (Top View)

Ordering and Marking Information

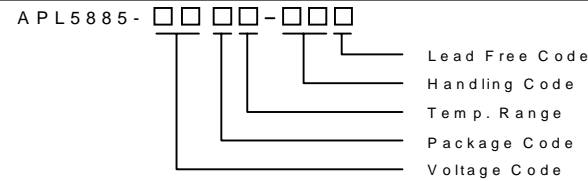
	Package Code D : SOT-89 E : TO-92 Temp. Range C : 0 to 70 °C Handling Code TU : Tube TR : Tape & Reel Voltage Code 18 : 1.8V 25 : 2.5V 33 : 3.3V Blank : Adjustable Version Lead Free Code L : Lead Free Device Blank: Original Device
APL5885 D : APL5885 XXXXX XXXXX - Date Code	APL5885 E : APL 5885 XXXXX XXXXX - Date Code
APL5885 -18 D : APL5885 XXXXX18 XXXXX - Date Code	APL5885 -18 E : APL 5885 XXXXX18 XXXXX - Date Code
APL5885 -25 D : APL5885 XXXXX25 XXXXX - Date Code	APL5885 -25 E : APL 5885 XXXXX25 XXXXX - Date Code
APL5885 -33 D : APL5885 XXXXX33 XXXXX - Date Code	APL5885 -33 E : APL 5885 XXXXX33 XXXXX - Date Code

ANPEC reserves the right to make changes to improve reliability or manufacturability without notice, and advise customers to obtain the latest version of relevant information to verify before placing orders.

Absolute Maximum Ratings

Symbol	Parameter	Rating	Unit
V_{IN}	Input Voltage	9	V
I_{OUT}	Output Current	500	mA
T_A	Operating Ambient Temperature Range	0 to 70	°C
T_J	Operating Ambient Temperature Range	-40 to +150	°C
T_{STG}	Storage Temperature Range	-65 to +150	°C
P_D	Power Dissipation Package	Interanl Limited	
θ_{JA}	Thermal Resistance	SOT-89	180
		TO-92	180

Electrical Characteristics ($T_A=25^\circ\text{C}$, unless otherwise noted)

Symbol	Parameter	Test Condition	APL5885			Unit
			Min.	Typ.	Max.	
V_N	Input Voltage		$V_{OUT}+1.45V$		8	V
V_{OUT}	Output Voltage	$I_{OUT}=10\text{mA}$	$0.9 V_{OUT}$		$1.02 V_{OUT}$	V
I_{OUT}	Output Current Capability	$\Delta V_{OUT}=2\%$	500			mA
I_{SC}	Short Circuit Current	$V_{OUT}<0.4V$		800		mA
I_Q	Quiescent Current	$V_N=5V, \text{No Load}$		6	10	mA
REG_{LINE}	Line Regulation	$T_J=0\sim 125^\circ\text{C}$				
		APL5885 $I_{OUT}=10\text{mA}, V_{OUT}+1.7V\leq V_{IN}\leq 8V$		3	6	mV
		APL5885-18 $I_{OUT}=0A, 3.5V\leq V_{IN}\leq 8V$				
		APL5885-25 $I_{OUT}=0A, 4.2V\leq V_{IN}\leq 8V$				
REG_{LOAD}	Load Regulation	$T_J=0\sim 125^\circ\text{C}$				
		APL5885 $(V_{IN}-V_{OUT})=1.7V, 0\leq I_{OUT}\leq 0.5A$		0.4	0.6	%
		APL5885-18 $V_{IN}=3.5V, 0\leq I_{OUT}\leq 0.5A$				
		APL5885-25 $V_{IN}=4.2V, 0\leq I_{OUT}\leq 0.5A$				
$V_{DROPOUT}$	Dropout Voltage	$I_{OUT}=500\text{mA}, \Delta V_{OUT}=1\%$		1300	1450	mV
PSRR	Power Supply Rejection Ratio	at 1kHz		55		dB
OTS	Over Temperature Shutdown			150		°C
E_N	Output Noise			100		μVrms
TC	Output Voltage Temperature Coefficient			100		ppm/°C

Block Diagram

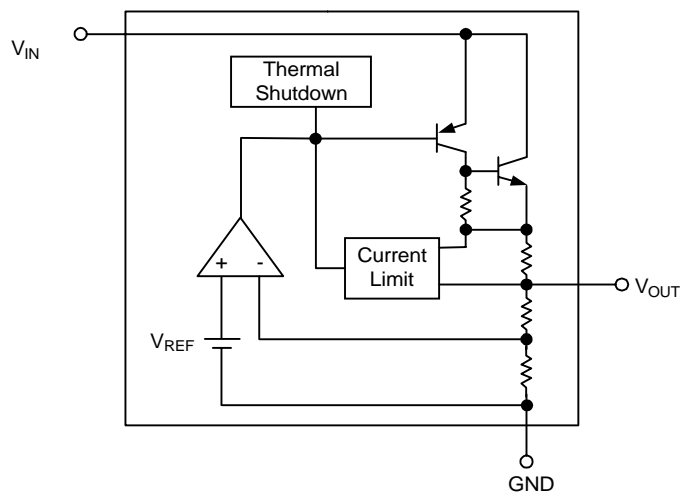

Application Schematic

1.25V to 7V Adjustable Regulator

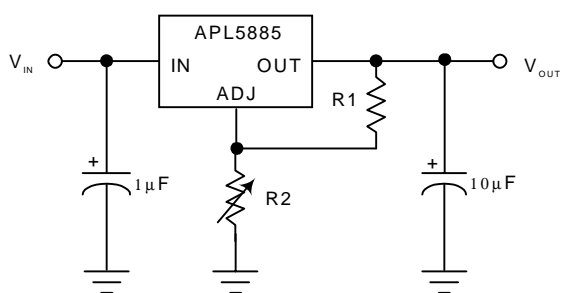

$$V_{OUT} = 1.250V \times \frac{R1 + R2}{R1}$$

Fixed 1.8V, 2.5V and 3.3V Regulator

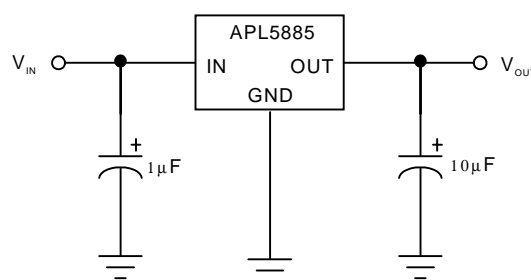

Typical Characteristics

Output Voltage vs. Temperature

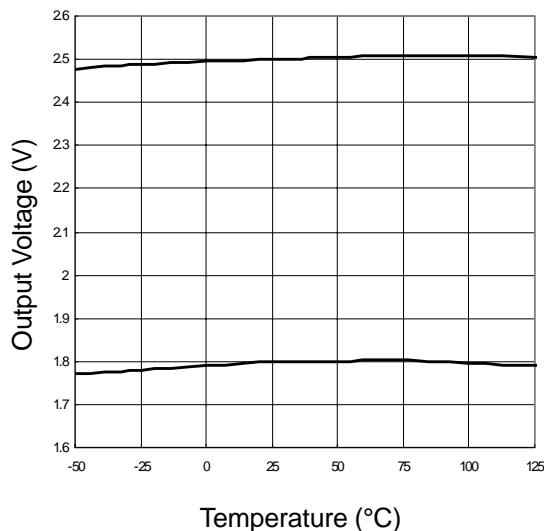

Output Voltage vs. Temperature

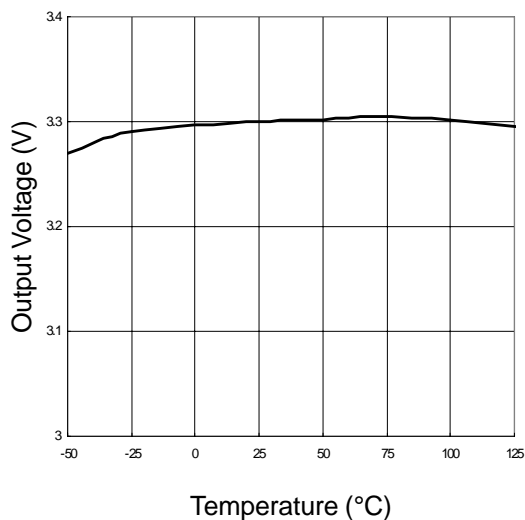

Line Transient Response

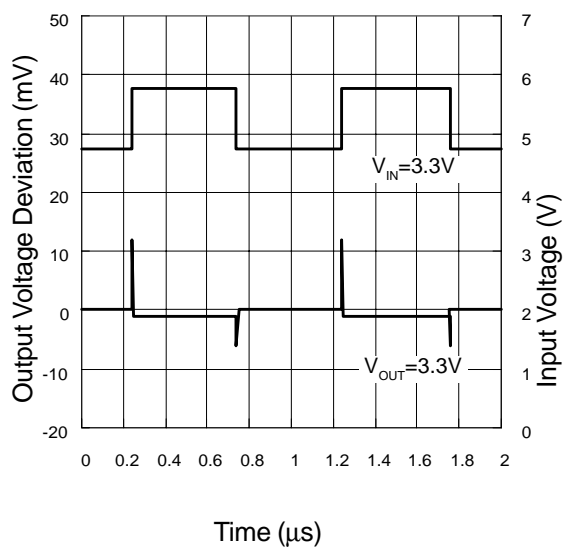

Load Transient Response

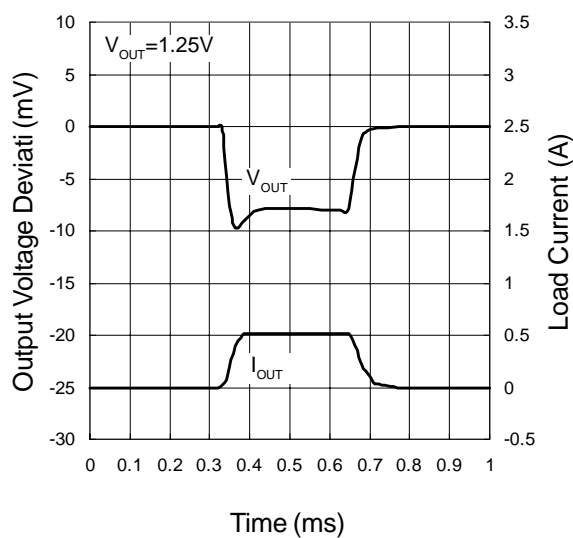

Typical Characteristics (Cont.)

Adjust Pin Current vs. Temperature

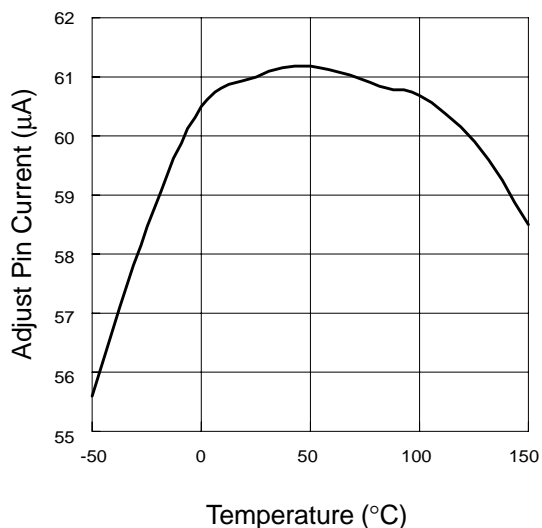

Output Voltage vs. Input Voltage

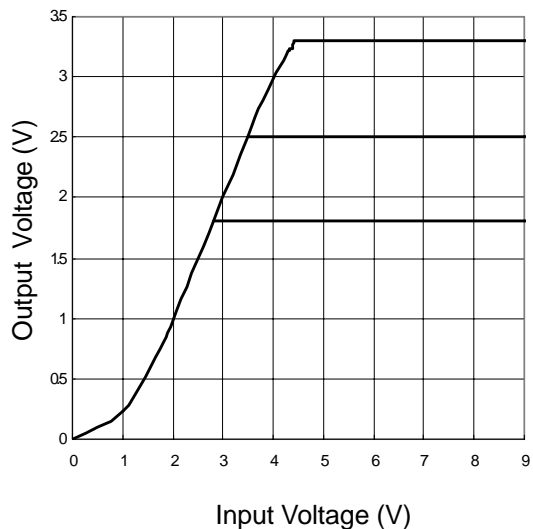

Short Circuit Current vs. Temperature

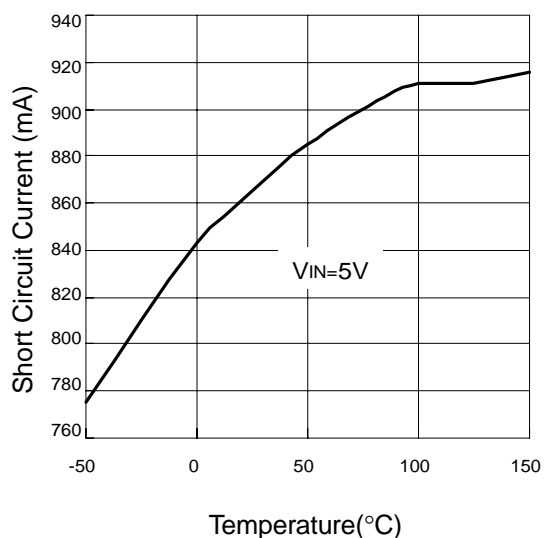

Load Regulation vs. Output Current

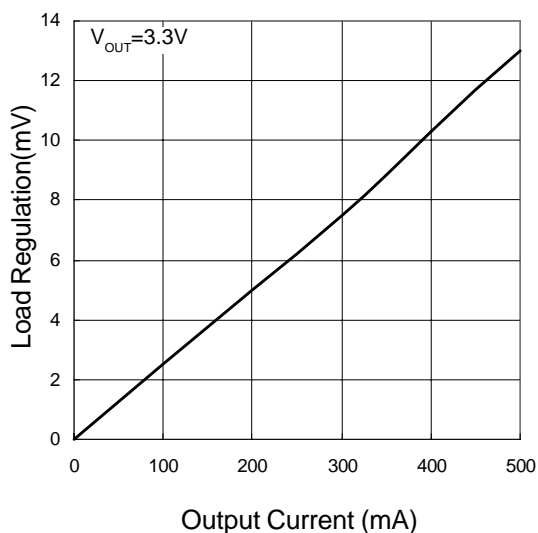

Typical Characteristics (Cont.)

Short Circuit Current vs. Input Voltage

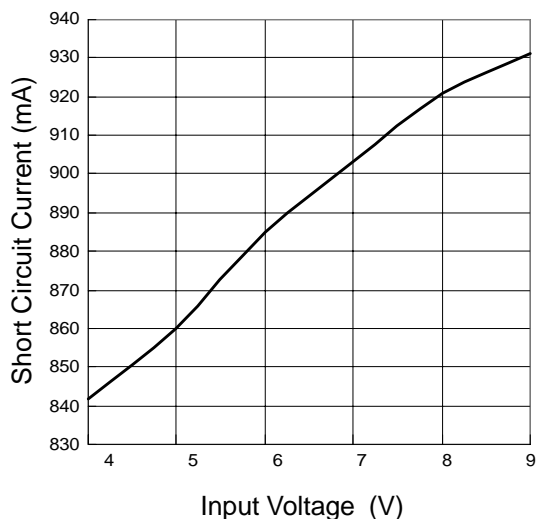

Output Current vs. Dropout Voltage

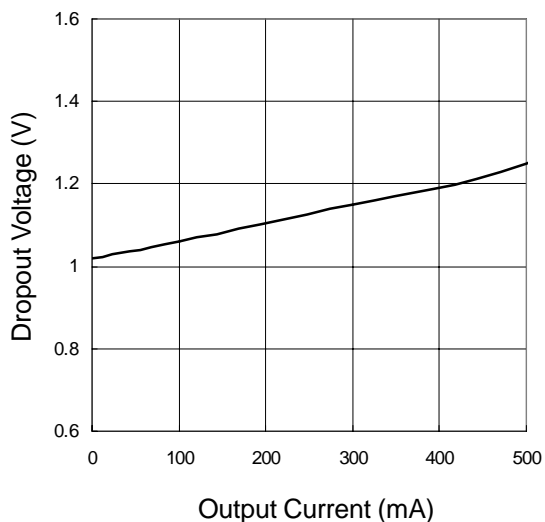

Quiescent Current vs. Temperature

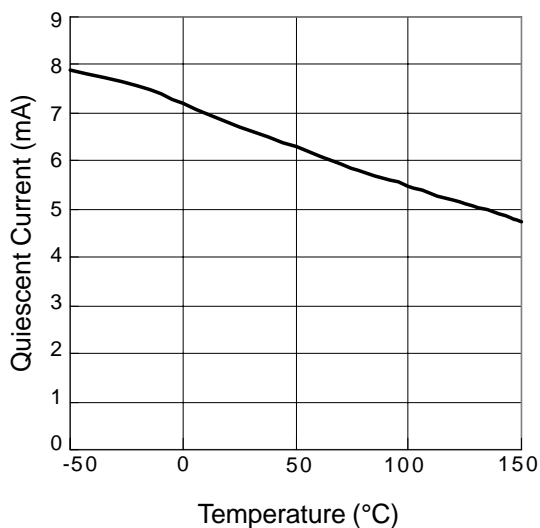

Input Current vs. Input Voltage

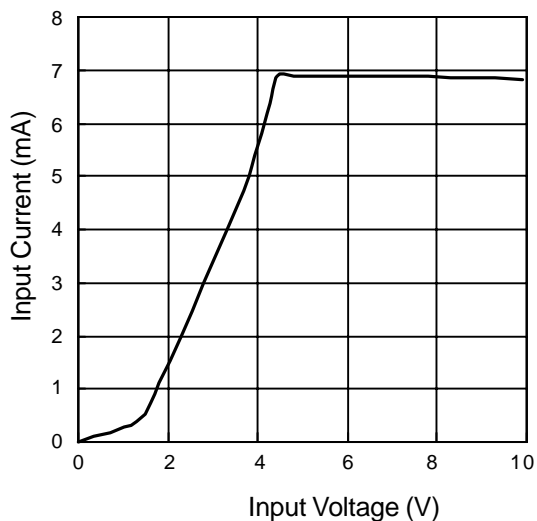

Packaging Information

TO-92

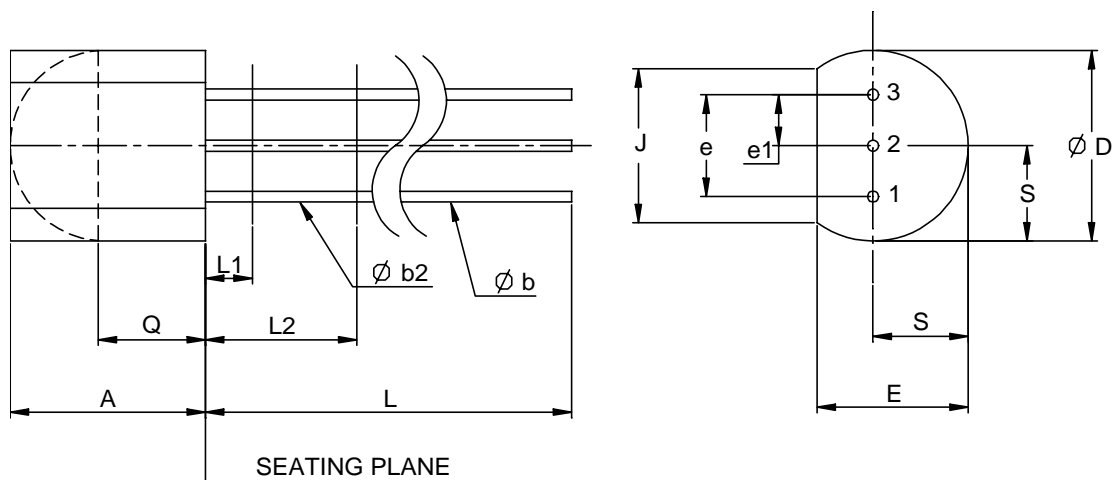

Dim	Millimeters		Inches	
	Min.	Max.	Min.	Max.
A	4.58	5.33	0.170	0.210
phi b	0.41	0.53	0.160	0.021
phi b2	0.41	0.48	0.160	0.019
phi D	4.96	5.20	0.175	0.205
E	3.94	4.19	0.125	0.165
e	2.42	2.66	0.095	0.105
e1	1.15	1.39	0.045	0.055
J	3.43		0.135	
L	12.70		0.500	
L1		1.27		0.050
L2	6.35		0.250	
Q	2.93		0.115	
S	2.42	2.66	0.080	0.105

Packaging Information

SOT-89 (Reference EIAJ ED-7500A Registration SC-62)

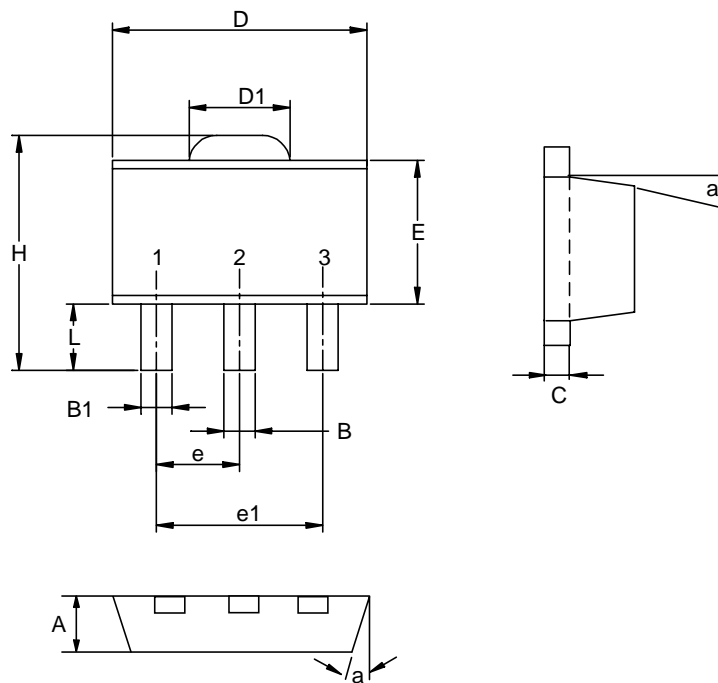

Dim	Millimeters		Inches	
	Min.	Max.	Min.	Max.
A	1.40	1.60	0.055	0.063
B	0.40	0.56	0.016	0.022
B1	0.35	0.48	0.014	0.019
C	0.35	0.44	0.014	0.017
D	4.40	4.60	0.173	0.181
D1	1.35	1.83	0.053	0.072
e	1.50 BSC		0.059 BSC	
e1	3.00 BSC		0.118 BSC	
E	2.29	2.60	0.090	0.102
H	3.75	4.25	0.148	0.167
L	0.80	1.20	0.031	0.047
α		10°		10°

Physical Specifications

Terminal Material	Solder-Plated Copper (Solder Material : 90/10 or 63/37 SnPb), 100%Sn
Lead Solderability	Meets EIA Specification RSI86-91, ANSI/J-STD-002 Category 3.

Reflow Condition (IR/Convection or VPR Reflow)

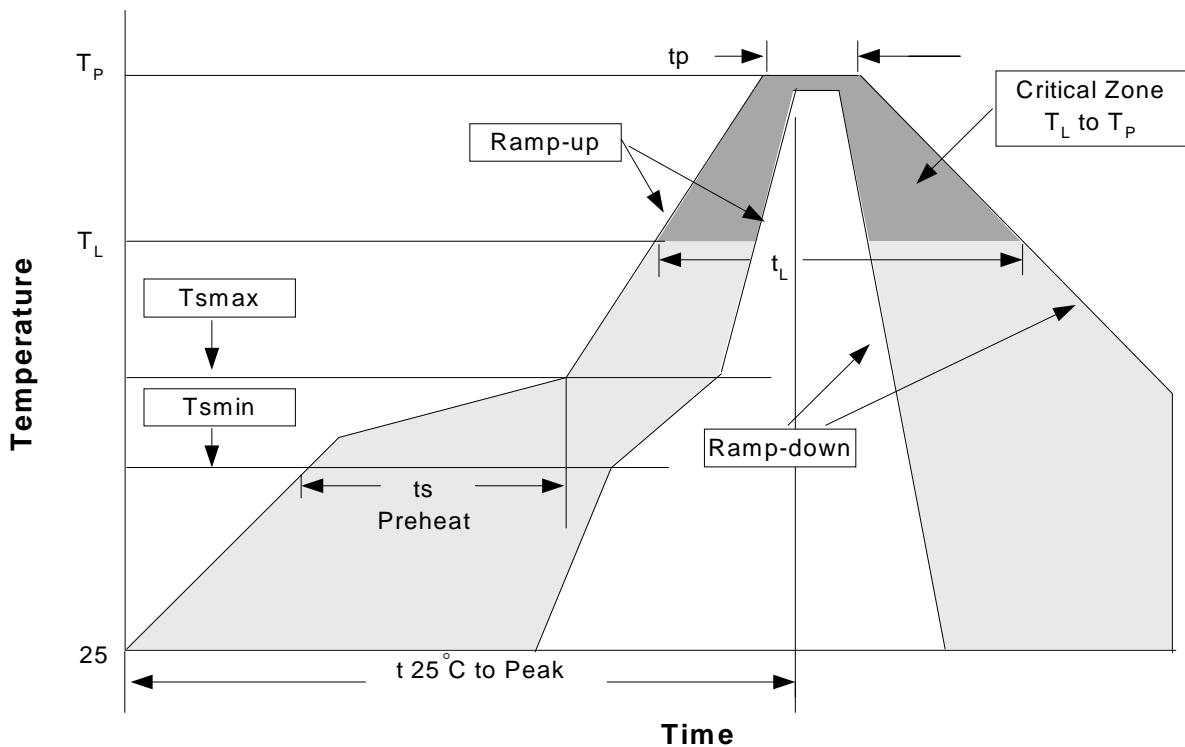

Classification Reflow Profiles

Profile Feature	Sn-Pb Eutectic Assembly		Pb-Free Assembly	
	Large Body	Small Body	Large Body	Small Body
Average ramp-up rate (T_L to T_P)	3°C/second max.		3°C/second max.	
Preheat				
- Temperature Min (T_{smin})	100°C		150°C	
- Temperature Mix (T_{smax})	150°C		200°C	
- Time (min to max)(t_s)	60-120 seconds		60-180 seconds	
T_{smax} to T_L				
- Ramp-up Rate			3°C/second max	
T_{smax} to T_L				
- Temperature(T_L)	183°C		217°C	
- Time (t_L)	60-150 seconds		60-150 seconds	
Peak Temperature(T_p)	225 +0/-5°C	240 +0/-5°C	245 +0/-5°C	250 +0/-5°C
Time within 5°C of actual Peak Temperature(t_p)	10-30 seconds	10-30 seconds	10-30 seconds	20-40 seconds
Ramp-down Rate	6°C/second max.		6°C/second max.	
Time 25°C to Peak Temperature	6 minutes max.		8 minutes max.	

Note: All temperatures refer to topside of the package. Measured on the body surface.

Reliability test Program

Test item	Method	Description
SOLDERABILITY	MIL-STD-883D-2003	245° C , 5 SEC
HOLT	MIL-STD-883D-1005.7	1000 Hrs Bias @ 125 °C
PCT	JESD-22-B, A102	168 Hrs, 100 % RH , 121 °C
TST	MIL-STD-883D-1011.9	-65° C ~ 150° C , 200 Cycles
ESD	MIL-STD-883D-3015.7	VHBM > 2KV, VMM > 200V
Latch-Up	JESD 78	10ms , $I_{tr} > 100mA$

Carrier Tape & Reel Dimensions

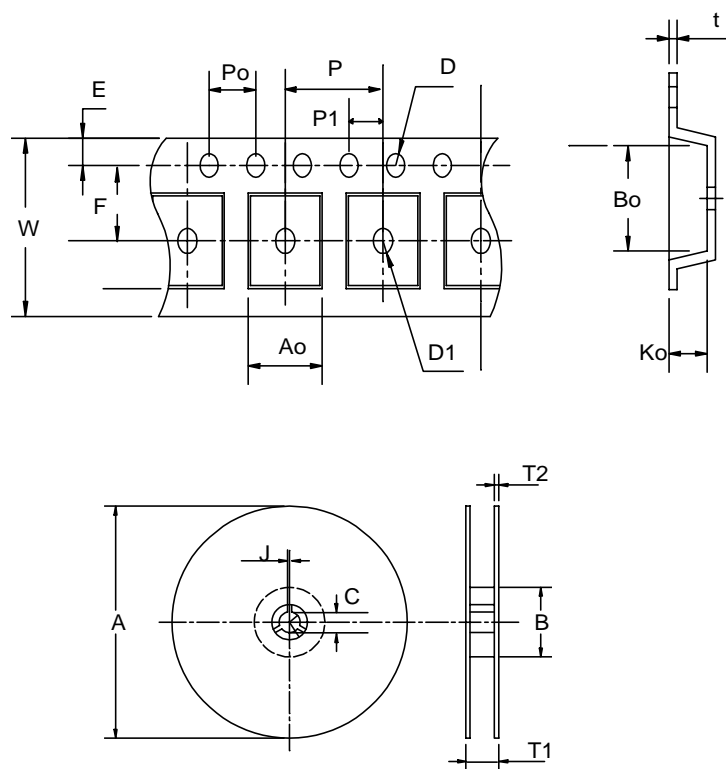

Application	A	B	C	J	T1	T2	W	P	E
SOT-89	178 ± 1	70 ± 2	13.5 ± 0.15	3 ± 0.15	14 ± 2	1.3 ± 0.3	12 + 0.3 12 - 0.1	8 ± 0.1	1.75 ± 0.1
Application	F	D	D1	Po	P1	Ao	Bo	Ko	t
SOT-89	5.5 ± 0.05	1.5 ± 0.1	1.5 ± 0.1	4.0 ± 0.1	2.0 ± 0.1	4.8 ± 0.1	4.5 ± 0.1	1.80 ± 0.1	0.3 ± 0.013

(mm)

Cover Tape Dimensions

Application	Carrier Width	Cover Tape Width	Devices Per Reel
SOT- 89	12	9.3	1000

Customer Service

Anpec Electronics Corp.

Head Office :

5F, No. 2 Li-Hsin Road, SBIP,

Hsin-Chu, Taiwan, R.O.C.

Tel : 886-3-5642000

Fax : 886-3-5642050

Taipei Branch :

7F, No. 137, Lane 235, Pac Chiao Rd.,

Hsin Tien City, Taipei Hsien, Taiwan, R. O. C.

Tel : 886-2-89191368

Fax : 886-2-89191369