

Hall Effect Sensor IC with Reverse Voltage Protection

Features

- On-chip Reverse Voltage Protection
- On-chip Hall Sensor
- Low Operating Supply Voltage : 3 V
- High Output Sinking Capability up to 400mA
- Versatile sensitivity and hysteresis setting
- Reliable and Rugged
- 4 pin TO-92M Package

Applications

- Brushless DC Fan
- Revolution Counting
- Brushless DC Motor
- Speed Measurement

General Description

The APX9141 is an integrated Hall Effect Sensor IC designed for electric commutation of DC brushless motor applications. The APX9141 still can operate at as low as 3 volts. The APX9141 is available in low cost TO -92M4 package with 3 different magnetic ranks.

Pin Description

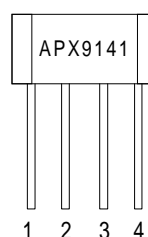

Front View

- 1 : V_{DD}
- 2 : DO
- 3 : DOB
- 4 : GND

Ordering Information

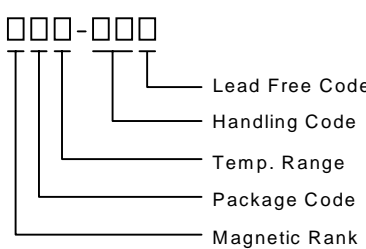
<p>APX9141 □□□-□□□</p>  <ul style="list-style-type: none"> Lead Free Code Handling Code Temp. Range Package Code Magnetic Rank 	<p>Magnetic Rank</p> <ul style="list-style-type: none"> AT : Bop , Brp < 50 Gauss A : Bop , Brp < 70 Gauss B : Bop , Brp < 100 Gauss D : Bop , Brp < 150 Gauss <p>Package Code</p> <ul style="list-style-type: none"> E : TO - 92M4 <p>Temp. Range</p> <ul style="list-style-type: none"> E : -20 to 85 °C <p>Handling Code</p> <ul style="list-style-type: none"> PB : Plastic Bag TB : Tape & Box TR : Tape & Reel <p>Lead Free Code</p> <ul style="list-style-type: none"> L : Lead Free Device Blank : Original Device
--	--

ANPEC reserves the right to make changes to improve reliability or manufacturability without notice, and advise customers to obtain the latest version of relevant information to verify before placing orders.

Block Diagram

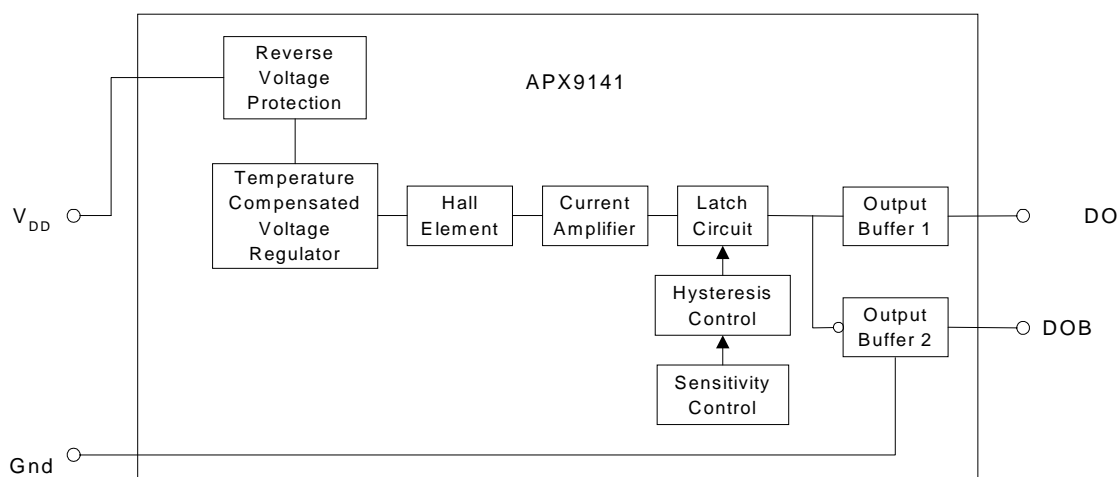

Absolute Maximum Ratings $T_A = 25^\circ\text{C}$ unless otherwise noted

Symbol	Parameter	Rating	Unit
V_{DD}	Supply Voltage	20	V
V_{BD}	Output Breakdown Voltage	55	V
I_{DD}	Supply Current	25	mA
I_{OUT}	Output Current – Continuous	400	mA
	Hold Current	600	
	Peak (Start Up)	800	
P_D	Maximum Power Dissipation	500	mW
T_A	Operating Ambient Temperature	-20 to 85	°C
T_{STG}	Storage Temperature Range	-65 to 150	
T_{SOL}	Soldering Temperature (10 Sec.)	260	

Electrical Characteristics $T_A = 25^\circ\text{C}$, $V_{DD}=20\text{V}$ unless otherwise noted

Symbol	Parameter	Test Condition	APX9141			Unit
			Min.	Typ.	Max.	
V_{DD}	Supply Voltage	Operating	3		20	V
V_{SAT}	Output Saturation Voltage	$V_{DD}=14\text{V}$, $I_{OUT}=400\text{mA}$, $B>Bop$		250	500	mV
I_{DD}	Supply Current	$V_{DD}=20\text{V}$, Output Open		20	25	mA
I_{Leak}^a	Output Leakage Current	$V_{OUT}=20\text{V}$, $V_{DD}=20\text{V}$, $B<Brp$		<0.1	10	μA
t_r^b	Output Rise Time	$V_{DD}=14\text{V}$, $R_L=820\Omega$ $C_L=20\text{pF}$		0.8	5	μs
t_f^b	Output Fall Time			0.1	1	μs
Δt^b	Switch Time Different			3.5	7	μs

Note ^a : No leakage current spike when IC start-up

^b : use Figure 1

Magnetic Characteristics $T_A = 25^\circ\text{C}$, $V_{DD} = 14\text{V}$ unless otherwise noted

Rank	Maximum Operate Point Bop	Maximum Release Point Brp	Unit
AT	+50	-50	Gauss
A	+70	-70	
B	+100	-100	
D	+150	-150	

Note : For 5cm and below DC fan application, grade A/AT device is recommended to avoid magnetic sensitivity problem. For above 5cm DC fan application, grade B device is acceptable for most cases.

Test Information

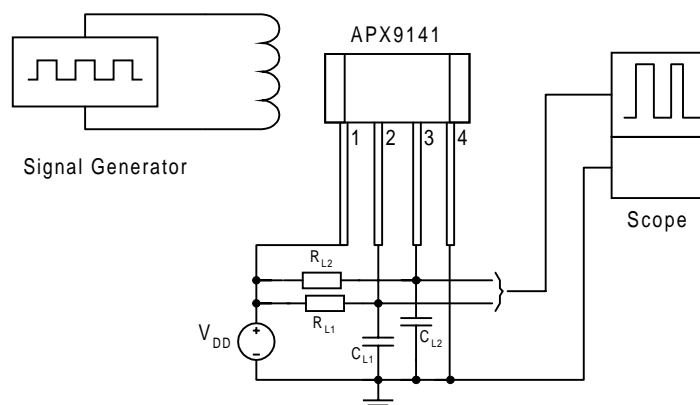

Figure 1 : Switching Circuit for Output Rise Time and Fall Time Measurement

Application Circuit

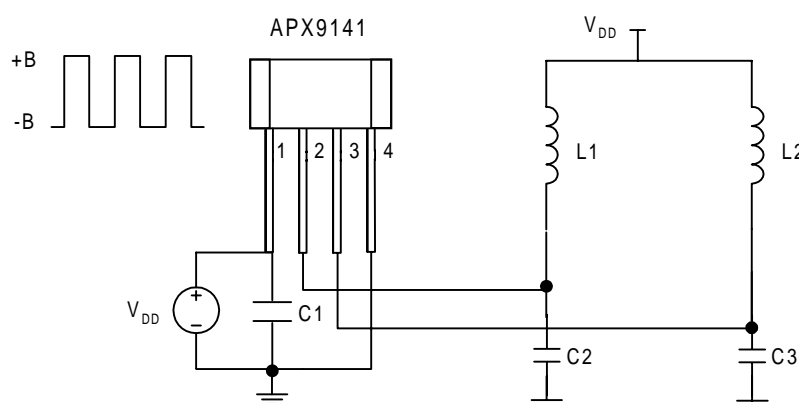
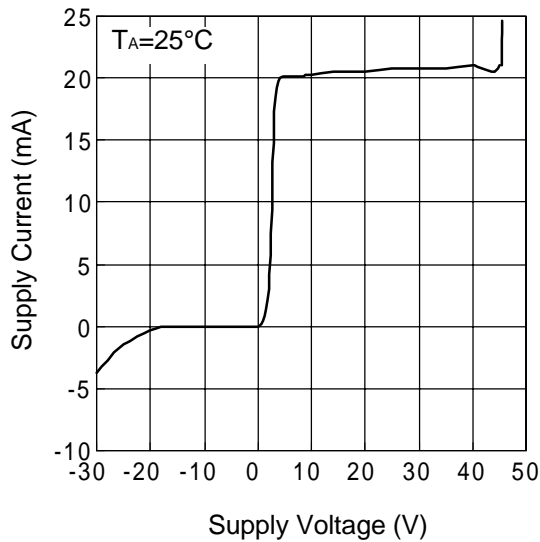

Figure 2 Typical DC brushless fan application circuit

Typical Characteristics

Supply Current vs. Supply Voltage



Output Saturation Voltage vs. Output Current

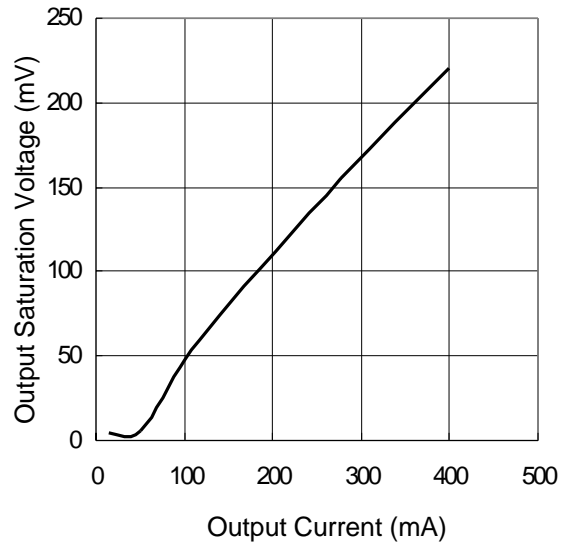

Output Low Voltage vs Ambient Temperature

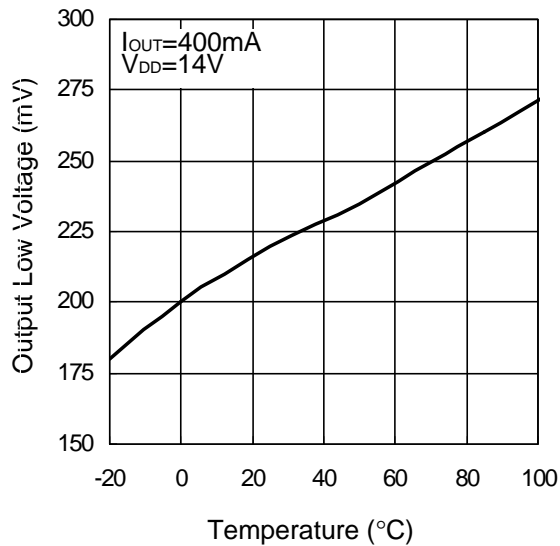

Supply Current vs Temperature

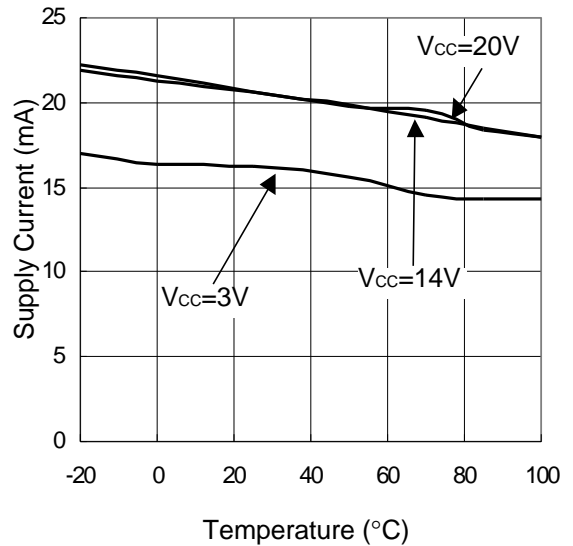

Typical Characteristics (Cont.)

Magnetic Switch Points vs Supply Voltage

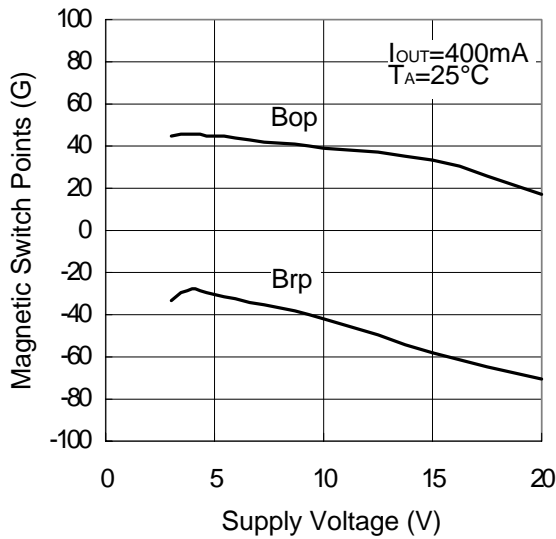

Magnetic Switch Points vs Temperature

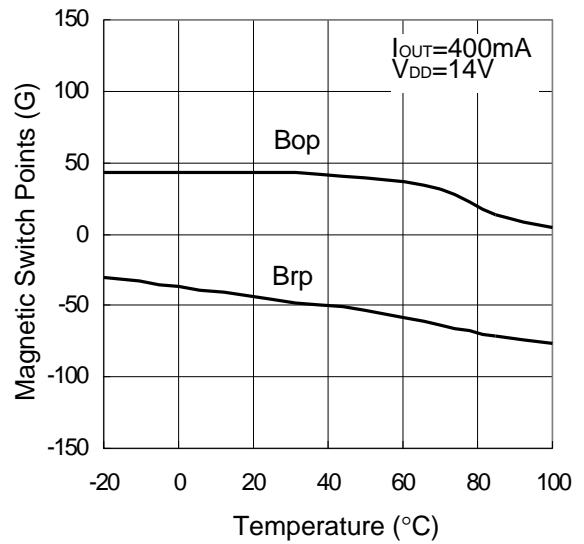

Power Dissipation vs. Ambient Temperature

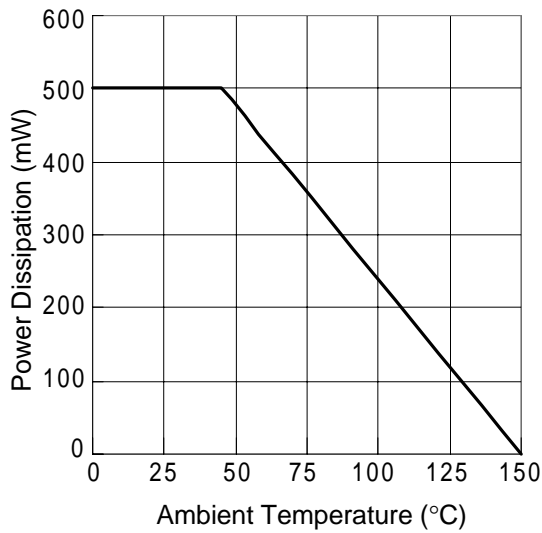

Output Breakdown Voltage vs. Current

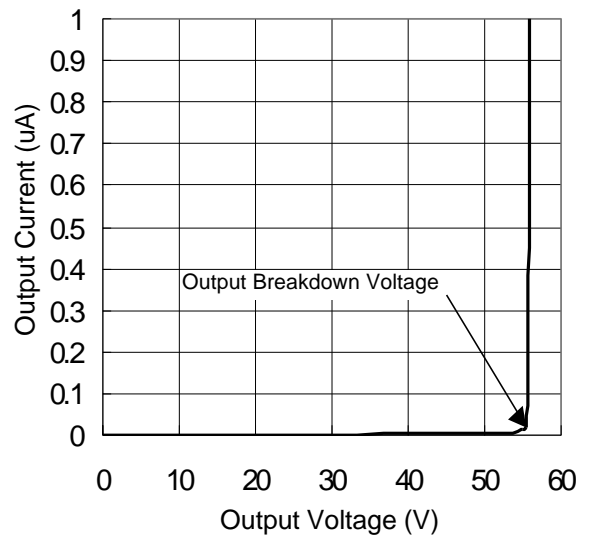

Package Information

TO-92M4

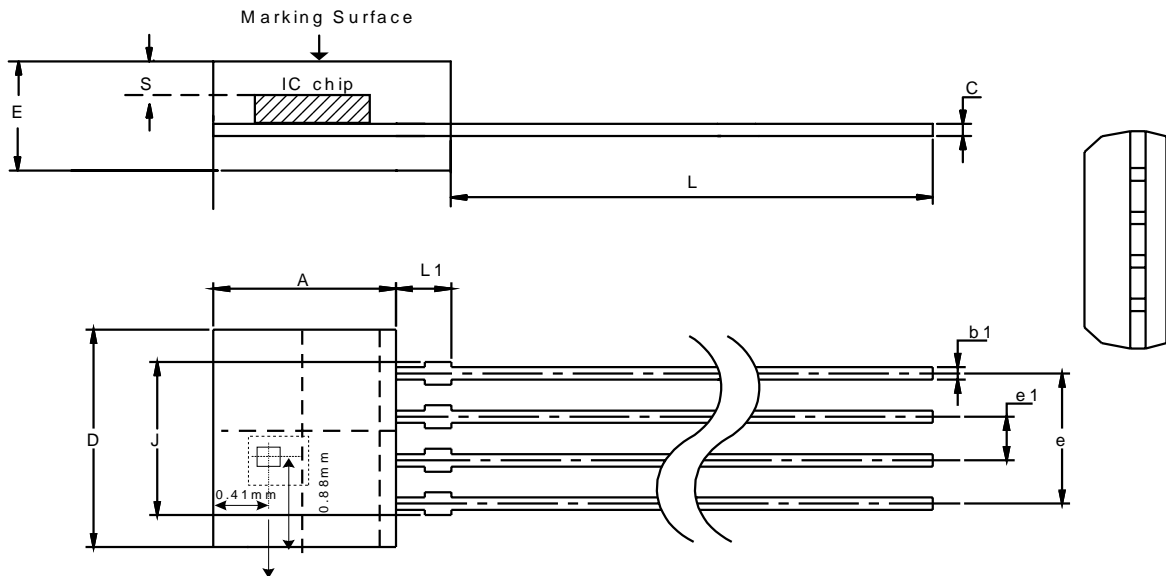

Sensitive Area ($0.286 \times 0.286 \text{ mm}^2$)
 Position of Hall Sensor
 reference to the top-left of package
 $x = 0.41 \pm 0.1 \text{ mm}$
 $y = 0.88 \pm 0.1 \text{ mm}$

Dim	Millimeters		Inches	
	Min.	Max.	Min.	Max.
A	3.60	3.70	0.141	0.145
b1	0.35	0.41	0.014	0.016
C	0.351	0.411	0.014	0.016
D	5.17	5.27	0.203	0.207
e	3.78	3.84	0.148	0.150
e1	1.24	1.30	0.049	0.051
E	1.50	1.60	0.059	0.063
J	4.04	4.34	0.158	0.170
L	14.0	15.0	0.549	0.588
L1	1.342	1.542	0.053	0.060
S	0.45	0.55	0.018	0.022

Physical Specifications

Terminal Material	Solder-Plated Copper (Solder Material : 90/10 or 63/37 SnPb), 100%Sn
Lead Solderability	Meets EIA Specification RSI86-91, ANSI/J-STD-002 Category 3.

Reflow Condition (IR/Convection or VPR Reflow)

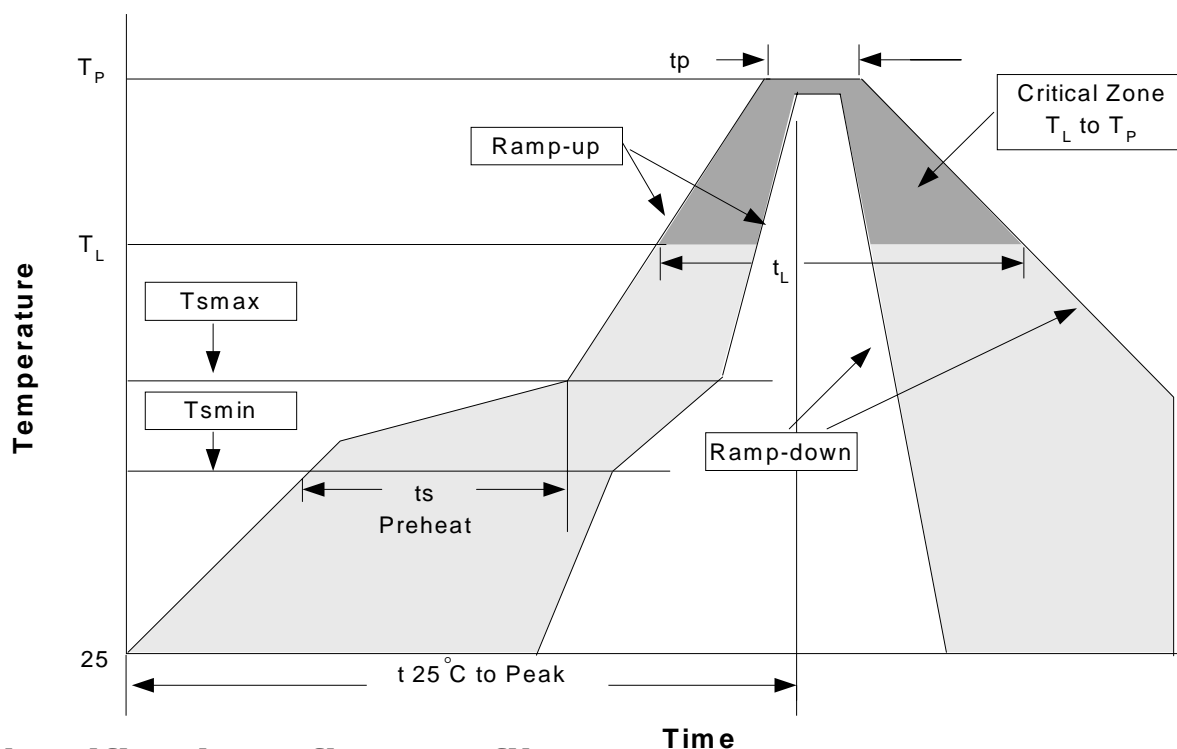

Classification Reflow Profiles

Profile Feature	Sn-Pb Eutectic Assembly		Pb-Free Assembly	
	Large Body	Small Body	Large Body	Small Body
Average ramp-up rate (T _L to T _P)	3°C/second max.		3°C/second max.	
Preheat				
- Temperature Min (T _{smin})	100°C		150°C	
- Temperature Mix (T _{smax})	150°C		200°C	
- Time (min to max)(t _s)	60-120 seconds		60-180 seconds	
T _{smax} to T _L				
- Ramp-up Rate			3°C/second max	
T _{smax} to T _L				
- Temperature(T _L)	183°C		217°C	
- Time (t _L)	60-150 seconds		60-150 seconds	
Peak Temperature(T _p)	225 +0/-5°C	240 +0/-5°C	245 +0/-5°C	250 +0/-5°C
Time within 5°C of actual Peak Temperature(t _p)	10-30 seconds	10-30 seconds	10-30 seconds	20-40 seconds
Ramp-down Rate	6°C/second max.		6°C/second max.	
Time 25°C to Peak Temperature	6 minutes max.		8 minutes max.	

Note: All temperatures refer to topside of the package. Measured on the body surface.

Customer Service

Anpec Electronics Corp.

Head Office :

5F, No. 2 Li-Hsin Road, SBIP,

Hsin-Chu, Taiwan, R.O.C.

Tel : 886-3-5642000

Fax : 886-3-5642050

Taipei Branch :

7F, No. 137, Lane 235, Pac Chiao Rd.,

Hsin Tien City, Taipei Hsien, Taiwan, R. O. C.

Tel : 886-2-89191368

Fax : 886-2-89191369