

CA3138, CA3138A

High-Current, High-Beta N-P-N Transistor Arrays

For Industrial, Commercial, and Military Applications
Four Isolated Discrete Sealed-Junction High-Current
N-P-N Transistors

Features:

- High Current — 1 A
- High Beta — 95 min. at $I_C = 500$ mA, $V_{CE} = 5$ V
- Low $V_{CE(SAT)}$ — 0.4 V max. at $I_C = 500$ mA, $I_B = 12.5$ mA
- Silicon Nitride Passivated
- Platinum Silicide Ohmic Contacts

The RCA-CA3138 and CA3138A are high-current n-p-n transistor arrays containing four isolated (discrete) sealed-junction high-current n-p-n transistors. They are intended for high-current, high-speed switching and driver applications.

The CA3138A has all the features and characteristics of the CA3138 but is intended for applications requiring premium grade specifications — higher rating for V_{CBO} of 25 volts and limits established for I_{CEO} , I_{EBO} , and h_{FE} at 10 mA.

The CA3138 and CA3138A are supplied in a 14-lead dual-in-line plastic package and operate over the full military temperature range of -55°C to $+125^\circ\text{C}$.

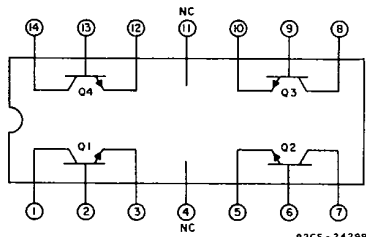

Fig. 1 — Terminal diagram (top view).

Applications:

- High-Current LED Driver
- Relay and Solenoid Driver
- Lamp Driver

MAXIMUM RATINGS, Absolute-Maximum Values:

COLLECTOR-TO-EMITTER VOLTAGE	15	V
With Base Open (V_{CEO})		
COLLECTOR-TO-BASE VOLTAGE		
With Emitter Open (V_{CBO})		
CA3138	20	V
CA3138A	25	V
EMITTER-TO-BASE VOLTAGE	5	V
With Collector Open (V_{EBO})		
COLLECTOR CURRENT (I_C)	1	A
POWER DISSIPATION (P_D)		
At T_A up to 25°C :		
For Each Transistor	1	W
Total Package	2	W
At T_A above 25°C derate linearly	20	$\text{mW}/^\circ\text{C}$
AMBIENT TEMPERATURE RANGE:		
Operating	-55 to $+125$	$^\circ\text{C}$
Storage	-65 to $+150$	$^\circ\text{C}$
LEAD TEMPERATURE (DURING SOLDERING):		
At distance $1/16 \pm 1/32$ inch (1.59 ± 0.79 mm) from case for 10 seconds max.	265	$^\circ\text{C}$

G E SOLID STATE DT DE 3875081 0014648 B

CA3138, CA3138A

ELECTRICAL CHARACTERISTICS at $T_A = 25^\circ\text{C}$

Characteristic	Test Conditions	LIMITS						Units
		CA3138			CA3138A			
		Min.	Typ.	Max.	Min.	Typ.	Max.	
Collector-to-Emitter Sustaining Voltage, $V_{CE(sus)}^*$	$I_C = 1\text{ mA}, I_B = 0$	15	20	—	15	20	—	V
Collector-to-Emitter Breakdown Voltage, $V_{(BR)CES}$	$I_C = 10\ \mu\text{A}$	20	55	—	25	60	—	V
Collector-to-Base Breakdown Voltage, $V_{(BR)CBO}$	$I_C = 10\ \mu\text{A}, I_E = 0$	20	55	—	25	60	—	V
Emitter-to-Base Breakdown Voltage, $V_{(BR)EBO}$	$I_E = 10\ \mu\text{A}, I_C = 0$	5	7.2	—	5	7.2	—	V
Base-to-Emitter Saturation Voltage, $V_{BE(sat)}^*$	$I_C = 500\text{ mA}, I_B = 12.5\text{ mA}$	0.7	0.81	1.1	0.7	0.81	1.1	V
Collector-to-Emitter Saturation Voltage, $V_{CE(sat)}^*$	$I_C = 500\text{ mA}, I_B = 12.5\text{ mA}$	—	0.26	0.4	—	0.26	0.4	V
Collector Cutoff Current	I_{CBO} $V_{CB} = 15\text{ V}$	—	0.03	1	—	0.02	0.1	μA
	I_{CEO} $V_{CE} = 10\text{ V}$	—	0.5	—	—	0.3	1.0	
	I_{EBO} $V_{EB} = 4\text{ V}$	—	0.01	—	—	0.01	0.1	
Static Forward-Current Transfer Ratio (Beta), h_{FE}^*	$I_C = 10\text{ mA}, V_{CE} = 5\text{ V}$	—	—	—	35	140	—	
	$I_C = 100\text{ mA}, V_{CE} = 5\text{ V}$	80	160	450	80	160	450	
	$I_C = 500\text{ mA}, V_{CE} = 5\text{ V}$	95	170	500	95	170	500	
	$I_C = 1\text{ A}, V_{CE} = 5\text{ V}$	40	170	—	40	170	—	
Small-Signal Forward Current Transfer Ratio, h_{fe}	$I_C = 50\text{ mA}, V_{CE} = 10\text{ V}, f = 100\text{ MHz}$	2	—	—	2	—	—	
Collector-to-Base Capacitance, C_{CB}	$V_{CB} = 10\text{ V}, I_E = 0$	—	18	—	—	18	—	pF
Emitter-to-Base Capacitance, C_{EB}	$V_{EB} = 0.5\text{ V}, I_C = 0$	—	77	—	—	77	—	pF
Rise Time (See Test Ckt. Fig. 6), t_r	$I_C = 570\text{ mA}$	—	6	—	—	6	—	ns
Fall Time (See Test Ckt. Fig. 6), t_f	$I_{B1} = 30\text{ mA}$	—	100	—	—	100	—	ns
Delay Time (See Test Ckt. Fig. 6), t_d	$I_{B2} = 0$	—	7.5	—	—	7.5	—	ns
Storage Time (See Test Ckt. Fig. 6), t_s		—	850	—	—	850	—	ns

*Pulse Conditions width = 300 μs , duty cycle = 1%.

Arrays

CA3138, CA3138A

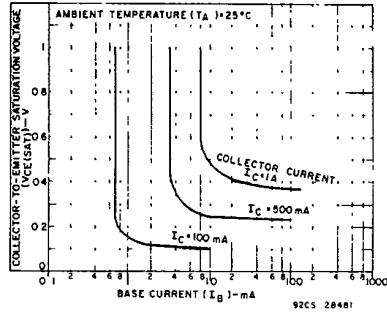

Fig. 2 - $V_{CE(sat)}$ vs I_B

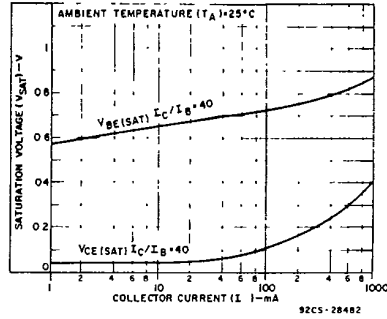

Fig. 3 - V_{sat} vs I_C

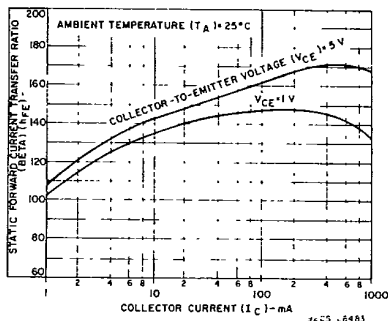

Fig. 4 - h_{FE} vs I_C

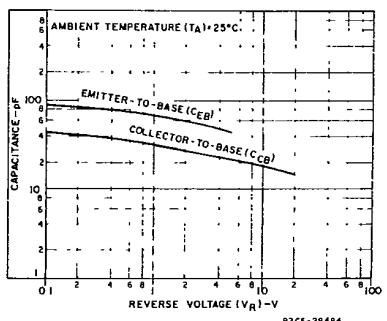

Fig. 5 - C_{CB} , C_{CE} vs V_R

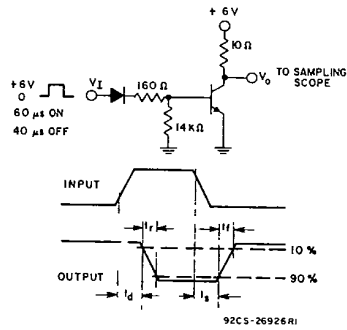

Fig. 6 - Switching time test circuit and waveforms.