



**CD4020BM/CD4020BC**  
**14-Stage Ripple Carry Binary Counters**  
**CD4040BM/CD4040BC**  
**12-Stage Ripple Carry Binary Counters**  
**CD4060BM/CD4060BC**  
**14-Stage Ripple Carry Binary Counters**

**General Description**

The CD4020BM/CD4020BC, CD4060BM/CD4060BC are 14-stage ripple carry binary counters, and the CD4040BM/CD4040BC is a 12-stage ripple carry binary counter. The counters are advanced one count on the negative transition of each clock pulse. The counters are reset to the zero state by a logical "1" at the reset input independent of clock.

**Features**

- Wide supply voltage range 1.0V to 15V
- High noise immunity 0.45 V<sub>DD</sub> (typ.)
- Low power TTL compatibility Fan out of 2 driving 74L or 1 driving 74LS
- Medium speed operation 8 MHz typ. at V<sub>DD</sub> = 10V
- Schmitt trigger clock input

**Connection Diagrams**

**Dual-In-Line Package**  
**CD4020BM/CD4020BC**

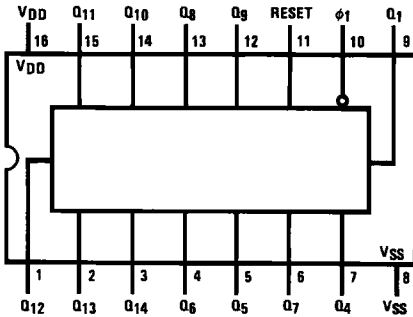

**Top View**

TL/F/5953-1

**Order Number CD4020B\*, CD4040B\* or CD4060B\***

\*Please look into Section 8, Appendix D for availability of various package types.

**Dual-In-Line Package**  
**CD4040BM/CD4040BC**

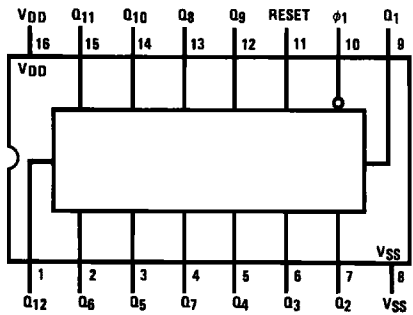

**Top View**

TL/F/5953-2

**Dual-In-Line Package**  
**CD4060BM/CD4060BC**

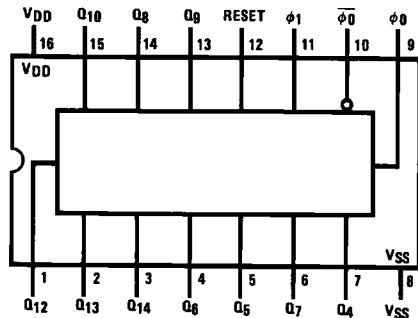

**Top View**

TL/F/5953-3

### Absolute Maximum Ratings (Notes 1 and 2)

If Military/Aerospace specified devices are required, contact the National Semiconductor Sales Office/Distributors for availability and specifications.

Supply Voltage ( $V_{DD}$ )	-0.5V to +18V
Input Voltage ( $V_{IN}$ )	-0.5V to $V_{DD}$ + 0.5V
Storage Temperature Range ( $T_S$ )	-65°C to +150°C
Package Dissipation ( $P_D$ )	
Dual-In-Line	700 mW
Small Outline	500 mW
Lead Temperature ( $T_L$ )	
(Soldering, 10 seconds)	260°C

### Recommended Operating Conditions

Supply Voltage ( $V_{DD}$ )	+3V to +15V
Input Voltage ( $V_{IN}$ )	0V to $V_{DD}$
Operating Temperature Range ( $T_A$ )	
CD40XXBM	-55°C to +125°C
CD40XXBC	-40°C to +85°C

### DC Electrical Characteristics CD40XXBM (Note 2)

Symbol	Parameter	Conditions	-55°C		+25°C			+125°C		Units
			Min	Max	Min	Typ	Max	Min	Max	
$I_{DD}$	Quiescent Device Current	$V_{DD} = 5V, V_{IN} = V_{DD}$ or $V_{SS}$		5			5		150	$\mu A$
		$V_{DD} = 10V, V_{IN} = V_{DD}$ or $V_{SS}$		10			10		300	$\mu A$
		$V_{DD} = 15V, V_{IN} = V_{DD}$ or $V_{SS}$		20			20		600	$\mu A$
$V_{OL}$	Low Level Output Voltage	$V_{DD} = 5V$		0.05		0	0.05		0.05	V
		$V_{DD} = 10V$		0.05		0	0.05		0.05	V
		$V_{DD} = 15V$		0.05		0	0.05		0.05	V
$V_{OH}$	High Level Output Voltage	$V_{DD} = 5V$	4.95		4.95	5		4.95		V
		$V_{DD} = 10V$	9.95		9.95	10		9.95		V
		$V_{DD} = 15V$	14.95		14.95	15		14.95		V
$V_{IL}$	Low Level Input Voltage	$V_{DD} = 5V, V_O = 0.5V$ or 4.5V		1.5		2	1.5		1.5	V
		$V_{DD} = 10V, V_O = 1.0V$ or 9.0V		3.0		4	3.0		3.0	V
		$V_{DD} = 15V, V_O = 1.5V$ or 13.5V		4.0		6	4.0		4.0	V
$V_{IH}$	High Level Input Voltage	$V_{DD} = 5V, V_O = 0.5V$ or 4.5V	3.5		3.5	3		3.5		V
		$V_{DD} = 10V, V_O = 1.0V$ or 9.0V	7.0		7.0	6		7.0		V
		$V_{DD} = 15V, V_O = 1.5V$ or 13.5V	11.0		11.0	9		11.0		V
$I_{OL}$	Low Level Output Current (See Note 3)	$V_{DD} = 5V, V_O = 0.4V$	0.64		0.51	0.88		0.36		mA
		$V_{DD} = 10V, V_O = 0.5V$	1.6		1.3	2.25		0.9		mA
		$V_{DD} = 15V, V_O = 1.5V$	4.2		3.4	8.8		2.4		mA
$I_{OH}$	High Level Output Current (See Note 3)	$V_{DD} = 5V, V_O = 4.6V$	-0.64		-0.51	-0.88		-0.36		mA
		$V_{DD} = 10V, V_O = 9.5V$	-1.6		-1.3	-2.25		-0.9		mA
		$V_{DD} = 15V, V_O = 13.5V$	-4.2		-3.4	-8.8		-2.4		mA
$I_{IN}$	Input Current	$V_{DD} = 15V, V_{IN} = 0V$		-0.10		-10 <sup>-5</sup>	-0.10		-1.0	$\mu A$
		$V_{DD} = 15V, V_{IN} = 15V$		0.10		10 <sup>-5</sup>	0.10		1.0	$\mu A$

**Note 1:** "Absolute Maximum Ratings" are those values beyond which the safety of the device cannot be guaranteed. They are not meant to imply that the devices should be operated at these limits. The tables of "Recommended Operating Conditions" and "Electrical Characteristics" provide conditions for actual device operation.

**Note 2:**  $V_{SS} = 0V$  unless otherwise specified.

**Note 3:** Data does not apply to oscillator points  $\phi_0$  and  $\bar{\phi}_0$  of CD4060BM/CD4060BC.  $I_{OH}$  and  $I_{OL}$  are tested one output at a time.

### DC Electrical Characteristics 40XXBC (Note 2)

Symbol	Parameter	Conditions	-40°C		+25°C			+85°C		Units
			Min	Max	Min	Typ	Max	Min	Max	
$I_{DD}$	Quiescent Device Current	$V_{DD} = 5V, V_{IN} = V_{DD}$ or $V_{SS}$		20			20		150	$\mu A$
		$V_{DD} = 10V, V_{IN} = V_{DD}$ or $V_{SS}$		40			40		300	$\mu A$
		$V_{DD} = 15V, V_{IN} = V_{DD}$ or $V_{SS}$		80			80		600	$\mu A$
$V_{OL}$	Low Level Output Voltage	$V_{DD} = 5V$		0.05		0	0.05		0.05	V
		$V_{DD} = 10V$		0.05		0	0.05		0.05	V
		$V_{DD} = 15V$		0.05		0	0.05		0.05	V

### DC Electrical Characteristics 40XXBC (Note 2) (Continued)

Symbol	Parameter	Conditions	-40°C		+25°C			+85°C		Units
			Min	Max	Min	Typ	Max	Min	Max	
V <sub>OH</sub>	High Level Output Voltage	V <sub>DD</sub> = 5V	4.95		4.95	5		4.95		V
		V <sub>DD</sub> = 10V	9.95		9.95	10		9.95		V
		V <sub>DD</sub> = 15V	14.95		14.95	15		14.95		V
V <sub>IL</sub>	Low Level Input Voltage	V <sub>DD</sub> = 5V, V <sub>O</sub> = 0.5V or 4.5V		1.5		2	1.5		1.5	V
		V <sub>DD</sub> = 10V, V <sub>O</sub> = 1.0V or 9.0V		3.0		4	3.0		3.0	V
		V <sub>DD</sub> = 15V, V <sub>O</sub> = 1.5V or 13.5V		4.0		6	4.0		4.0	V
V <sub>IH</sub>	High Level Input Voltage	V <sub>DD</sub> = 5V, V <sub>O</sub> = 0.5V or 4.5V	3.5		3.5	3		3.5		V
		V <sub>DD</sub> = 10V, V <sub>O</sub> = 1.0V or 9.0V	7.0		7.0	6		7.0		V
		V <sub>DD</sub> = 15V, V <sub>O</sub> = 1.5V or 13.5V	11.0		11.0	9		11.0		V
I <sub>OL</sub>	Low Level Output Current (See Note 3)	V <sub>DD</sub> = 5V, V <sub>O</sub> = 0.4V	0.52		0.44	0.88		0.36		mA
		V <sub>DD</sub> = 10V, V <sub>O</sub> = 0.5V	1.3		1.1	2.25		0.9		mA
		V <sub>DD</sub> = 15V, V <sub>O</sub> = 1.5V	3.6		3.0	8.8		2.4		mA
I <sub>OH</sub>	High Level Output Current (See Note 3)	V <sub>DD</sub> = 5V, V <sub>O</sub> = 4.6V	-0.52		-0.44	-0.88		-0.36		mA
		V <sub>DD</sub> = 10V, V <sub>O</sub> = 9.5V	-1.3		-1.1	-2.25		-0.9		mA
		V <sub>DD</sub> = 15V, V <sub>O</sub> = 13.5V	-3.6		-3.0	-8.8		-2.4		mA
I <sub>IN</sub>	Input Current	V <sub>DD</sub> = 15V, V <sub>IN</sub> = 0V		-0.30		-10 <sup>-5</sup>	-0.30		-1.0	μA
		V <sub>DD</sub> = 15V, V <sub>IN</sub> = 15V		0.30		10 <sup>-5</sup>	0.30		1.0	μA

### AC Electrical Characteristics\* CD4020BM/CD4020BC, CD4040BM/CD4040BC

T<sub>A</sub> = 25°C, C<sub>L</sub> = 50 pF, R<sub>L</sub> = 200k, t<sub>r</sub> = t<sub>f</sub> = 20 ns, unless otherwise noted

Symbol	Parameter	Conditions	Min	Typ	Max	Units
t <sub>PHL1</sub> , t <sub>PLH1</sub>	Propagation Delay Time to Q <sub>1</sub>	V <sub>DD</sub> = 5V V <sub>DD</sub> = 10V V <sub>DD</sub> = 15V		250 100 75	550 210 150	ns ns ns
t <sub>PHL</sub> , t <sub>PLH</sub>	Interstage Propagation Delay Time from Q <sub>n</sub> to Q <sub>n+1</sub>	V <sub>DD</sub> = 5V V <sub>DD</sub> = 10V V <sub>DD</sub> = 15V		150 60 45	330 125 90	ns ns ns
t <sub>THL</sub> , t <sub>TLH</sub>	Transition Time	V <sub>DD</sub> = 5V V <sub>DD</sub> = 10V V <sub>DD</sub> = 15V		100 50 40	200 100 80	ns ns ns
t <sub>WL</sub> , t <sub>WH</sub>	Minimum Clock Pulse Width	V <sub>DD</sub> = 5V V <sub>DD</sub> = 10V V <sub>DD</sub> = 15V		125 50 40	335 125 100	ns ns ns
t <sub>rCL</sub> , t <sub>fCL</sub>	Maximum Clock Rise and Fall Time	V <sub>DD</sub> = 5V V <sub>DD</sub> = 10V V <sub>DD</sub> = 15V			No Limit No Limit No Limit	ns ns ns
f <sub>CL</sub>	Maximum Clock Frequency	V <sub>DD</sub> = 5V V <sub>DD</sub> = 10V V <sub>DD</sub> = 15V	1.5 4 5	4 10 12		MHz MHz MHz
t <sub>PHL(R)</sub>	Reset Propagation Delay	V <sub>DD</sub> = 5V V <sub>DD</sub> = 10V V <sub>DD</sub> = 15V		200 100 80	450 210 170	ns ns ns
t <sub>WH(R)</sub>	Minimum Reset Pulse Width	V <sub>DD</sub> = 5V V <sub>DD</sub> = 10V V <sub>DD</sub> = 15V		200 100 80	450 210 170	ns ns ns
C <sub>in</sub>	Average Input Capacitance	Any Input		5	7.5	pF
C <sub>pd</sub>	Power Dissipation Capacitance			50		pF

\*AC Parameters are guaranteed by DC correlated testing.

### AC Electrical Characteristics\* CD4060BM/CD4060BC

$T_A = 25^\circ\text{C}$ ,  $C_L = 50\text{ pF}$ ,  $R_L = 200\text{ k}$ ,  $t_r = t_f = 20\text{ ns}$ , unless otherwise noted

Symbol	Parameter	Conditions	Min	Typ	Max	Units
$t_{PHL4}$ , $t_{PLH4}$	Propagation Delay Time to $Q_4$	$V_{DD} = 5\text{V}$ $V_{DD} = 10\text{V}$ $V_{DD} = 15\text{V}$		550 250 200	1300 525 400	ns ns ns
$t_{PHL}$ , $t_{PLH}$	Interstage Propagation Delay Time from $Q_n$ to $Q_{n+1}$	$V_{DD} = 5\text{V}$ $V_{DD} = 10\text{V}$ $V_{DD} = 15\text{V}$		150 60 45	330 125 90	ns ns ns
$t_{THL}$ , $t_{TLH}$	Transition Time	$V_{DD} = 5\text{V}$ $V_{DD} = 10\text{V}$ $V_{DD} = 15\text{V}$		100 50 40	200 100 80	ns ns ns
$t_{WL}$ , $t_{WH}$	Minimum Clock Pulse Width	$V_{DD} = 5\text{V}$ $V_{DD} = 10\text{V}$ $V_{DD} = 15\text{V}$		170 65 50	500 170 125	ns ns ns
$t_{rCL}$ , $t_{fCL}$	Maximum Clock Rise and Fall Time	$V_{DD} = 5\text{V}$ $V_{DD} = 10\text{V}$ $V_{DD} = 15\text{V}$			No Limit No Limit No Limit	ns ns ns
$f_{CL}$	Maximum Clock Frequency	$V_{DD} = 5\text{V}$ $V_{DD} = 10\text{V}$ $V_{DD} = 15\text{V}$	1 3 4	3 8 10		MHz MHz MHz
$t_{PHL(R)}$	Reset Propagation Delay	$V_{DD} = 5\text{V}$ $V_{DD} = 10\text{V}$ $V_{DD} = 15\text{V}$		200 100 80	450 210 170	ns ns ns
$t_{WH(R)}$	Minimum Reset Pulse Width	$V_{DD} = 5\text{V}$ $V_{DD} = 10\text{V}$ $V_{DD} = 15\text{V}$		200 100 80	450 210 170	ns ns ns
$C_{in}$	Average Input Capacitance	Any Input		5	7.5	pF
$C_{pd}$	Power Dissipation Capacitance			50		pF

\*AC Parameters are guaranteed by DC correlated testing.

### CD4060B Typical Oscillator Connections

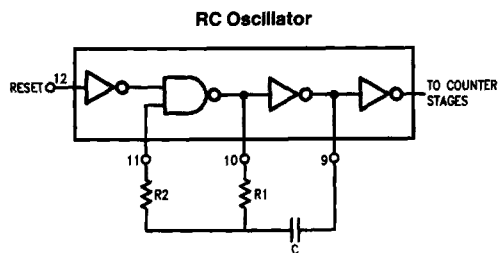

TL/F/5953-4

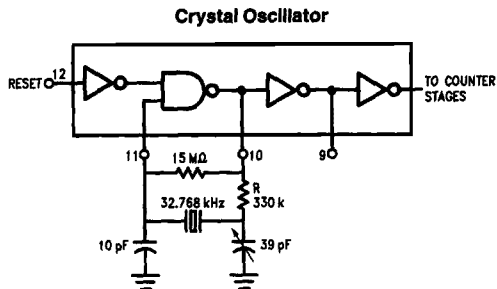

TL/F/5953-5

### Schematic Diagrams

CD4020BM/CD4020BC Schematic Diagram

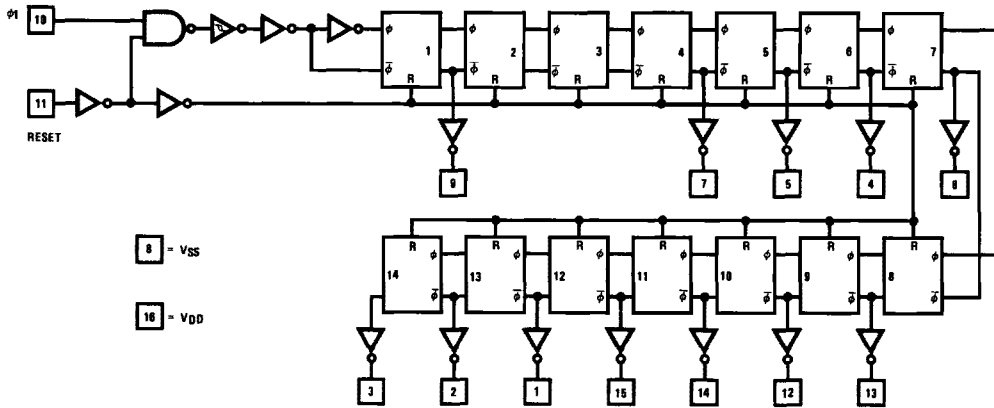

TL/F/5953-6

CD4040BM/CD4040BC Schematic Diagram

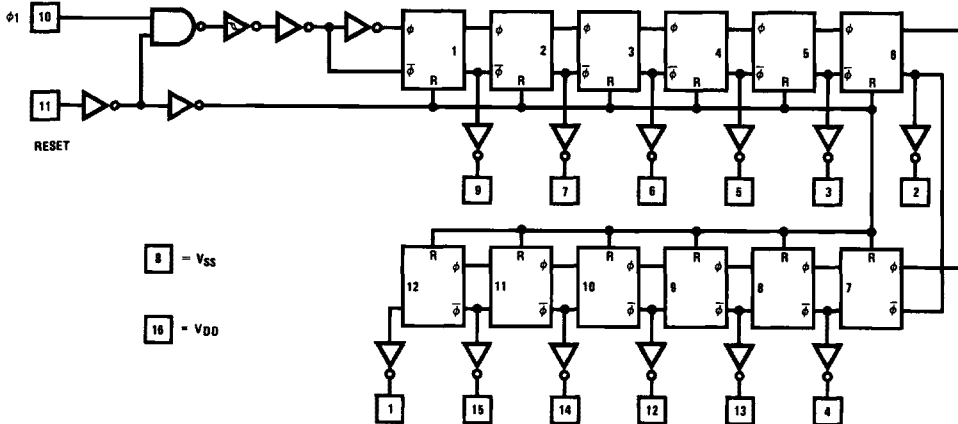

TL/F/5953-7

CD4060BM/CD4060BC Schematic Diagram

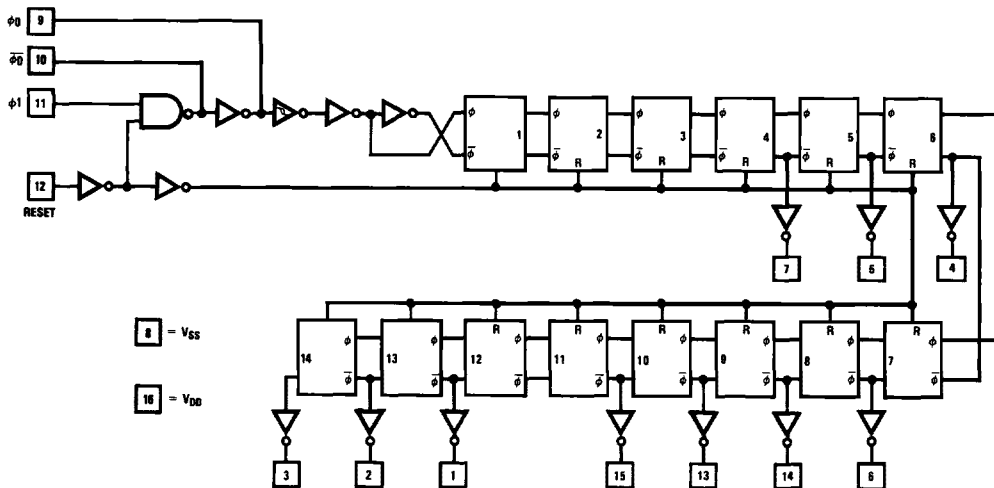

TL/F/5953-8