

## CD4503BM/CD4503BC Hex Non-Inverting TRI-STATE® Buffer

### General Description

The CD4503B is a hex non-inverting TRI-STATE buffer with high output current sink and source capability. TRI-STATE outputs make it useful in bus-oriented applications. Two separate disable inputs are provided. Buffers 1 through 4 are controlled by the disable 4 input. Buffers 5 and 6 are controlled by the disable 2 input. A high level on either disable input will cause those gates on its control line to go into a high impedance state.

### Features

- Wide supply voltage range 3.0  $V_{DC}$  to 18  $V_{DC}$
- TRI-STATE outputs
- Symmetrical turn on/turn off delays
- Symmetrical output rise and fall times
- Pin-for-pin replacement for MM80C97 and MC14503

### Schematic and Connection Diagrams

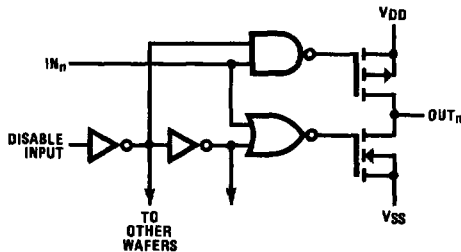

TL/F/5989-1

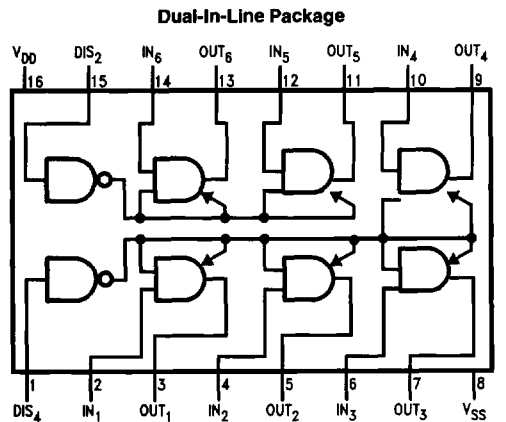

TL/F/5989-2

#### Top View

#### Order Number CD4503B\*

\*Please look into Section 8, Appendix D for availability of various package types.

### Truth Table

In	Disable Input	Out
0	0	0
1	0	1
X	1	TRI-STATE

X = Don't Care

**Absolute Maximum Ratings** (Notes 1 and 2)

If Military/Aerospace specified devices are required, contact the National Semiconductor Sales Office/Distributors for availability and specifications.

Supply Voltage ( $V_{DD}$ )	-0.5V to +18V
Input Voltage ( $V_{IN}$ )	-0.5V to +0.5V
Storage Temperature Range ( $T_S$ )	-65°C to +150°C
Power Dissipation ( $P_D$ )	700 mW
Dual-In-Line	500 mW
Small Outline	
Lead Temperature ( $T_L$ )	260°C
(Soldering, 10 seconds)	

**Recommended Operating Conditions** (Note 2)

Supply Voltage ( $V_{DD}$ )	+3V to +15V
Operating Temperature Range ( $T_A$ )	-55°C to +125°C
CD4503BM	-40°C to +85°C
CD4503BC	

**DC Electrical Characteristics** CD4503BM (Note 2)

Symbol	Parameter	Conditions	-55°C		+25°			+125°C		Units
			Min	Max	Min	Typ	Max	Min	Max	
$I_{DD}$	Quiescent Device Current	$V_{DD} = 5V,$ $V_{IN} = V_{DD}$ or $V_{SS}$ $V_{DD} = 10V,$ $V_{IN} = V_{DD}$ or $V_{SS}$ $V_{DD} = 15V,$ $V_{IN} = V_{DD}$ or $V_{SS}$		1			1		30	$\mu A$
				2			2		60	$\mu A$
				4			4		120	$\mu A$
$V_{OL}$	Low Level Output Voltage	$V_{IN} = V_{DD}$ or 0 $V_{DD} = 5V$ $V_{DD} = 10V$ $V_{DD} = 15V$		0.05		0	0.05		0.05	V
				0.05		0	0.05		0.05	V
				0.05		0	0.05		0.05	V
$V_{OH}$	High Level Output Voltage	$V_{IN} = V_{DD}$ or 0 $V_{DD} = 5V$ $V_{DD} = 10V$ $V_{DD} = 15V$	4.95		4.95	5		4.95		V
			9.95		9.95	10		9.95		V
			14.95		14.95	15		14.95		V
$V_{IL}$	Low Level Input Voltage	$V_{DD} = 5V,$ $V_O = 4.5V$ or $0.5V$ $V_{DD} = 10V,$ $V_O = 9.0V$ or $1.0V$ $V_{DD} = 15V,$ $V_O = 13.5V$ or $1.5V$		1.5		2.25	1.5		1.5	V
				3.0		4.50	3.0		3.0	V
				4.0		6.75	4.0		4.0	V
$V_{IH}$	High Level Input Voltage	$V_{DD} = 5V,$ $V_O = 0.5V$ or $4.5V$ $V_{DD} = 10V,$ $V_O = 1.0V$ or $9.0V$ $V_{DD} = 15V,$ $V_O = 1.5V$ or $13.5V$	3.5		3.5	2.75		3.5		V
			7.0		7.0	5.5		7.0		V
			11.0		11.0	8.25		11.0		V
$I_{OL}$	Low Level Output Current (Note 3)	$V_{DD} = 4.5V, V_{OL} = 0.4V$ $V_{DD} = 5.0V, V_{OL} = 0.4V$ $V_{DD} = 10V, V_{OL} = 0.5V$ $V_{DD} = 15V, V_{OL} = 1.5V$	2.80		2.30	2.55		1.60		$mA$
			3.00		2.40	2.75		1.75		$mA$
			7.85		6.35	7.00		4.45		$mA$
			19.95		16.10	25.00		11.30		$mA$
$I_{OH}$	High Level Output Current (Note 3)	$V_{DD} = 5V, V_{OH} = 4.6V$ $V_{DD} = 10V, V_{OH} = 9.5V$ $V_{DD} = 15V, V_{OH} = 13.5V$	-1.28		-1.02	-1.76		-0.72		$mA$
			-3.20		-2.60	-4.5		-1.8		$mA$
			-8.20		-6.80	-17.6		-4.8		$mA$
$I_{OZ}$	TRI-STATE Leakage Current	$V_{DD} = 15V$		$\pm 0.1$		$\pm 10^{-4}$	$\pm 0.1$		$\pm 1.0$	$\mu A$
$I_{IN}$	Input Current	$V_{DD} = 15V$		$\pm 0.1$		$\pm 10^{-4}$	$\pm 0.1$		$\pm 1.0$	$\mu A$

**Note 1:** "Absolute Maximum Ratings" are those values beyond which the safety of the device cannot be guaranteed. They are not meant to imply that the devices should be operated at these limits. The tables of "Recommended Operating Conditions" and "Electrical Characteristics" provide conditions for actual device operation.

**Note 2:**  $V_{SS} = 0V$  unless otherwise specified.

**Note 3:**  $I_{OH}$  and  $I_{OL}$  are tested one output at a time.

## DC Electrical Characteristics CD4503BC (Note 2)

Symbol	Parameter	Conditions	-40°C		+25°C			+85°C		Units
			Min	Max	Min	Typ	Max	Min	Max	
I <sub>DD</sub>	Quiescent Device Current	V <sub>DD</sub> = 5V, V <sub>IN</sub> = V <sub>DD</sub> or V <sub>SS</sub>		4			4		30	μA
		V <sub>DD</sub> = 10V, V <sub>IN</sub> = V <sub>DD</sub> or V <sub>SS</sub>		8			8		60	μA
		V <sub>DD</sub> = 15V, V <sub>IN</sub> = V <sub>DD</sub> or V <sub>SS</sub>		16			16		120	μA
V <sub>OL</sub>	Low Level Output Voltage	V <sub>IN</sub> = V <sub>DD</sub> or 0 V <sub>DD</sub> = 5V		0.05		0	0.05		0.05	V
		V <sub>DD</sub> = 10V		0.05		0	0.05		0.05	V
		V <sub>DD</sub> = 15V		0.05		0	0.05		0.05	V
V <sub>OH</sub>	High Level Output Voltage	V <sub>IN</sub> = V <sub>DD</sub> or 0 V <sub>DD</sub> = 5V	4.95		4.95			4.95		V
		V <sub>DD</sub> = 10V	9.95		9.95			9.95		V
		V <sub>DD</sub> = 15V	14.95		14.95			14.95		V
V <sub>IL</sub>	Low Level Input Voltage	V <sub>DD</sub> = 5V, V <sub>O</sub> = 4.5V or 0.5V		1.5		2.25	1.5		1.5	V
		V <sub>DD</sub> = 10V, V <sub>O</sub> = 9.0V or 1.0V		3.0		4.50	3.0		3.0	V
		V <sub>DD</sub> = 15V, V <sub>O</sub> = 13.5V or 1.5V		4.0		6.75	4.0		4.0	V
V <sub>IH</sub>	High Level Input Voltage	V <sub>DD</sub> = 5V, V <sub>O</sub> = 0.5V or 4.5V	3.5		3.5	2.75		3.5		V
		V <sub>DD</sub> = 10V, V <sub>O</sub> = 1.0V or 9.0V	7.0		7.0	5.5		7.0		V
		V <sub>DD</sub> = 15V, V <sub>O</sub> = 1.5V or 13.5V	11.0		11.0	8.25		11.0		V
I <sub>OL</sub>	Low Level Output Current (Note 3)	V <sub>DD</sub> = 4.5V, V <sub>OL</sub> = 0.4V	2.30		1.95	2.65		1.60		mA
		V <sub>DD</sub> = 5.0V, V <sub>OL</sub> = 0.4V	2.5		2.10	2.75		1.75		mA
		V <sub>DD</sub> = 10V, V <sub>OL</sub> = 0.5V	6.5		5.45	7.0		4.45		mA
		V <sub>DD</sub> = 15V, V <sub>OL</sub> = 1.5V	16.50		13.80	25.00		11.30		mA
I <sub>OH</sub>	High Level Output Current (Note 3)	V <sub>DD</sub> = 5V, V <sub>OH</sub> = 4.6V	-1.04		-0.88	-1.76		-0.7		mA
		V <sub>DD</sub> = 10V, V <sub>OH</sub> = 9.5V	-2.60		-2.2	-4.50		-1.8		mA
		V <sub>DD</sub> = 15V, V <sub>OH</sub> = 13.5V	-7.2		-6.0	-17.6		-4.8		mA
I <sub>TL</sub>	TRI-STATE Leakage Current	V <sub>DD</sub> = 15V		±0.3		±10 <sup>-4</sup>	±0.3		±1.0	μA
I <sub>IN</sub>	Input Current	V <sub>DD</sub> = 15V		±0.3		±10 <sup>-5</sup>	±0.3		±1.0	μA

**Note 1:** "Absolute Maximum Ratings" are those values beyond which the safety of the device cannot be guaranteed. They are not meant to imply that the devices should be operated at these limits. The tables of "Recommended Operating Conditions" and "Electrical Characteristics" provide conditions for actual device operation.

**Note 2:** V<sub>SS</sub> = 0V unless otherwise specified.

### AC Electrical Characteristics\* CD4503B

$T_A = 25^\circ\text{C}$ ,  $C_L = 50\text{ pF}$ ,  $R_L = 200\text{ k}\Omega$ , Input  $t_r = t_f = 20\text{ ns}$ , unless otherwise specified

Symbol	Parameter	Conditions	Min	Typ	Max	Units
$t_{PHL}$ , $t_{PLH}$	Propagation Delay Time	$V_{DD} = 5\text{V}$		75	100	ns
		$V_{DD} = 10\text{V}$		35	40	ns
		$V_{DD} = 15\text{V}$		25	30	ns
$t_{PLZ}$ , $t_{PHZ}$	Propagation Delay Time, Logical Level to High Impedance State	$V_{DD} = 5\text{V}$		80	125	ns
		$V_{DD} = 10\text{V}$		40	90	ns
		$V_{DD} = 15\text{V}$		35	70	ns
$t_{PZL}$ , $t_{PZH}$	Propagation Delay Time, High Impedance State to Logical Level	$V_{DD} = 5\text{V}$		95	175	ns
		$V_{DD} = 10\text{V}$		40	80	ns
		$V_{DD} = 15\text{V}$		35	70	ns
$t_{TLH}$	Output Rise Time	$V_{DD} = 5\text{V}$		45	80	ns
		$V_{DD} = 10\text{V}$		23	40	ns
		$V_{DD} = 15\text{V}$		18	35	ns
$t_{THL}$	Output Fall Time	$V_{DD} = 5\text{V}$		45	80	ns
		$V_{DD} = 10\text{V}$		23	40	ns
		$V_{DD} = 15\text{V}$		18	35	ns

\*AC Parameters are guaranteed by DC correlated testing.

### AC Test Circuits and Switching Time Waveforms

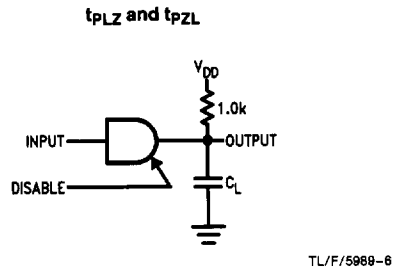
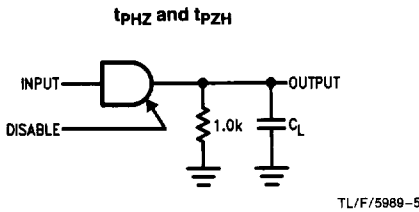
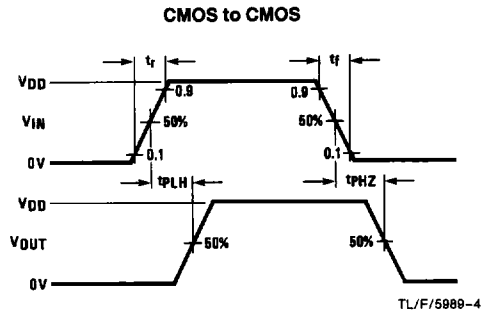
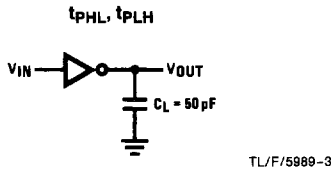

AC Test Circuits and Switching Time Waveforms (Continued)

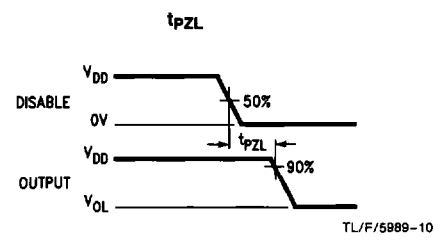
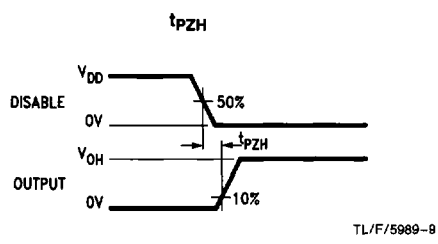
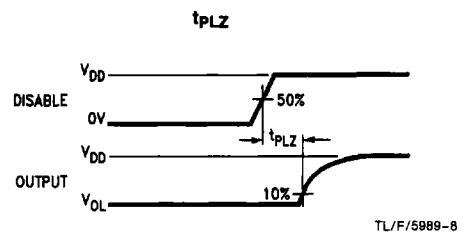
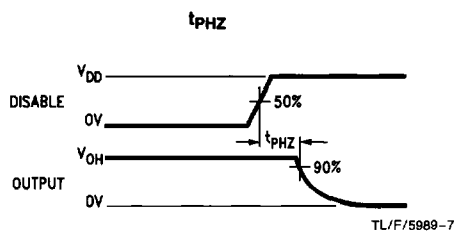

Note: Delays measured with input  $t_r, t_f \leq 20$  ns.