

LAN/Soft V.92 Modem Combo with Integrated Physical Layer Device Set for PCI/Mini PCI

CX81210 Network Controller and CX20493 SmartDAA™ 3 Line Side Device

Overview

The Conexant™ low-cost LAN/Soft V.92 Combo Device set with Conexant's integrated physical layer technology and third generation SmartDAA™ technology (SmartDAA 3) supports 10/100 Ethernet networking and host-processed V.92 analog data modem with V.44 data compression/14.4 kbps fax modem operation. By combining the MAC, PHY and modem system side device into one device, this device set constitutes the most compact, lowest cost Ethernet/soft V.92 chipset in existence. Only two chips are needed to accomplish the level of communication functionality that previously took three or even four devices. This device set is ideal for applications in the notebook, "broadband ready" consumer desktop, and SOHO desktop PC markets requiring a low-cost, flexible LAN/modem communications solution.

This device set consists of a CX81210 Network Controller with Integrated Physical Layer device in a 208-ball fine pitch ball grid array (FPBGA) and a CX20493 SmartDAA 3 Line Side Device (LSD) in a 28-pin quad flat no-lead (QFN) package. (Table 1). A simplified device set interface is illustrated in Figure 1.

The CX81210 Network Controller contains an integrated PHY device, provides a direct PCI bus connection to the host processor, and connects to the Conexant CX20493 SmartDAA 3 device through the OEM-supplied DIB for connecting to the PSTN/GSTN telephone line in the U.S./Japan/Canada and worldwide.

The CX81210 Network Controller integrates internal circuits into a single VLSI (very large scale integration) die. Internal circuits include clock, ARM7 processor, PCI Bus interface logic, control and status registers, ROM, RAM, IEEE 802.3-compliant Media Access Control (MAC), MII, IEEE 802.3-compliant PHY Transceiver, SmartDAA 3 system side device (SSD), general purpose input/output registers, and internal ringwake filter.

Modem data pump and controller functions are processed in a Pentium MMX-compatible PC using host-signal processing modem software (i.e., soft modem).

In ITU-T V.92/V.90/K56flex data mode, the modem can receive data at speeds up to 56 kbps from a digitally connected V.92/V.90 or K56flex-compatible central site modem. A V.92/V.90/K56flex modem takes advantage of the PSTN which is primarily digital except for the client modem to central office local loop and are ideal for applications such as remote access to an Internet Service Provider (ISP), on-line service, or corporate site. In this mode, the modem can transmit data at speeds up to 48 kbps in V.92 mode or up to V.34 rates in V.90 mode.

(Continued on Page 3)

Features

General Features

- Optimized integrated LAN interface/soft V.92 modem for low-cost solution
 - IEEE 802.3 10BASE-T and 100BASE-TX MAC and PHY
 - Host-processed (soft) V.92 modem
 - Concurrent operation of LAN and modem functions
 - Glueless 32-bit PCI master interface
 - PXE using BIOS ROM
 - DMI 2.0 compliant
 - Integrated power management functions
 - Modem hardware incorporates Conexant SmartDAA technology and proprietary soft modem buffering
 - Dual +3.3 V (analog) and 1.8 V (digital) power supplies for low power CMOS implementation

(Continued on Page 3)

Table 1. LAN/V.92-PCI Modem Device Set Models and Part Numbers

Model/Order/Part Numbers		
Device Set Order No.	Network Controller [208-Pin FPBGA] Part No.	SmartDAA 3 Line Side Device (LSD) [28-Pin QFN] Part No.
DSCN-L200-203	CX81210-31	CX20493-21

Figure 1. LAN/V.92-PCI Modem Device Set Simplified Hardware Interface

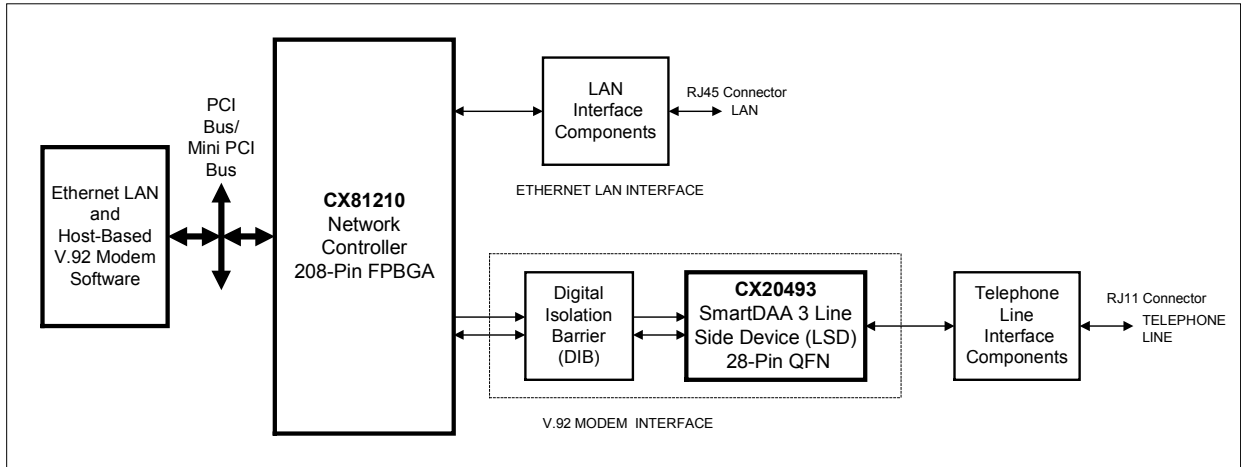

101793_001

Overview (Continued)

In V.34 data mode, the modem operates at line speeds up to 33.6 kbps.

Data compression (V.44/V.42 bis/MNP 5) and error correction (V.42/MNP 2-4) modes are supported to maximize data throughput and data transfer integrity. V.44 is a more efficient data compression than V.42 bis that significantly increases downstream throughput thus reducing the download time for the types of files associated with Internet use, such as Web pages and uncompressed data such as in graphics, image, audio, and document files. V.44 data compression can achieve compression rates of more than 25% over V.42bis. Typical compression ratio for V.44 on Web type data is approximately 6-1 resulting in overall effective data throughput rate up to 300 kbps for a 56-kbps connection. Non-error-correcting mode is also supported.

Conexant's SmartDAA 3 technology also offers the following advantages over discrete and other silicon DAAs:

- Incorporating Conexant's proprietary DIB design (patent pending) and other innovative DAA features, the SmartDAA 3 architecture simplifies application design, minimizes layout area, and reduces component cost for worldwide support.
- The SmartDAA 3 architecture eliminates the need for a costly line transformer, relays, and opto-isolators typically used in discrete DAA (Data Access Arrangement) implementations. Product implementation is also simplified by eliminating the need for country-specific board configurations enabling worldwide homologation of a single modem board design.
- The SmartDAA 3 system-side-powered DAA operates reliably without drawing power from the line and operates on long loops and poor line conditions.
- The SmartDAA 3 uses a fully differential digital interface which provides robust performance in the presence of common mode noise.
- Many SmartDAA 3 functions are software configurable providing a flexible solution to often changing worldwide regulations.
- Enhanced features, such as monitoring of local extension status without going off-hook, are also supported.
- For over a decade, Conexant has assisted customers with DAA technology and homologation. This expertise and system level approach has been leveraged in this product.
- Remote audio recording and remote audio playback over the telephone line interface is supported using A-Law, μ -Law, or linear coding at 8000 Hz sample rate to support applications such as digital telephone answering machine (TAM) and voice annotation.
- Fax Group 3 send and receive rates are supported up to 14.4 kbps with T.30 protocol.
- V.80 synchronous access mode supports host-controlled communication protocols, e. g., H.324 video conferencing.

Mini-PCI and PCI reference design kits are available to minimize application design time and costs.

Features (Continued)

General Features (Continued)

- Fully integrated 10BASE-T/100BASE-TX physical layer 1 interface
 - Full-duplex or half-duplex operation at 10 or 100 Mbps data rate
 - Auto-negotiation support per 802.3 standard
 - On-chip transmit filters provide direct drive capability for Category 3 and 5 UTP
 - Same magnetic module for 10 or 100 Mbps operation
 - Integrated high performance clock recovery requiring no external filters
 - Activity, link, full duplex, and speed LED display outputs
 - Auto polarity correction for 10BASE-T mode of operation
 - Loopback mode for network diagnostic testing
 - IEEE 802.3 100BASE-TX compliant with integrated ANSI X3.263 TP-PMD physical sublayer including adaptive equalization and baseline wander compensation
 - Wake-on-Link capability for intermediate power savings
- CX81210 Network Controller integrated internal hardware
 - ARM7 processor
 - Ethernet LAN MAC with IEEE 802.3-compliant MII to 10/100 Ethernet PHY
 - Modem system side interface to CX20493 SmartDAA 3 Line Side Device (LSD)
 - PCI master interface
 - Serial EEPROM interface
 - Five General Purpose Input/Output (GPIO) lines
- 32-bit PCI Bus host interface
 - Compliant with PCI Local Bus Specification Rev. 2.2 and Mini PCI Specification Draft 1.0.
 - Master PCI DMA
 - PCI Bus Mastering interface
 - 33 MHz PCI clock support

- Wired for Management (WfM) Support
 - WfM 2.0 compliance
 - Power management capabilities
 - Advanced Configuration and Power Interface (ACPI) 1.20A, and PCI Power Management specifications compliance
 - Magic Packet support
 - Network Wake-Up Packet (NWUP)
 - Wake on interesting packets and link status change
- Supports Power Management
 - Compliant with PCI Bus Power Management Interface Specification, Version 1.1
 - ACPI Power Management Registers
 - PME# support
 - Vaux/Vpci power switching support
 - VauxDET support
- System compatibility
 - Windows 9x/2000/ME/XP operating systems
 - Microsoft's PC 2001 Design Initiative compliant
 - Unimodem/V compliant
 - Pentium 166 MHz MMX-compatible PC or greater
 - 16 MB RAM or more
- Provided drivers
 - NDIS5 and LINUX drivers
- Small packages
 - CX81210 Network Controller: 208-pin 17 mm x 17 mm FPBGA
 - CX20493 SmartDAA 3 Line Side Device: 28-pin QFN

High-Performance Ethernet LAN Interface Features

- Dynamic transmit chaining with multiple priorities transmit queues
- Full-duplex support at both 10 and 100 Mbps operation
- TX-DMA/RX-DMA arbitration scheme on full-duplex mode
- IEEE 802.3u Auto-Negotiation support
- Separate receive and transmit FIFOs and corresponding DMA controllers
- 4-KB Transmit FIFO and 4-KB Receive FIFO
- Fast back-to-back transmission support with minimum interframe spacing
- IEEE 802.3 10BASE-T/100BASE-TX compliant

Data/Fax Modem Features

- Data modem with receive rates up to 56 kbps and send rates up to 48 kbps in V.92 mode or up to V.34 rates in V.90 mode
 - V.92, V.90, K56flex, V.34, V.32 bis, V.32, V.22 bis, V.22, V.23, and V.21; Bell 212A and Bell 103 modulation modes
 - Quick connect
 - Modem-on-hold
 - V.250 and V.251 commands

- Data compression and error correction
 - V.44 data compression for optimal downloading of Internet Web pages and files
 - V.42 bis and MNP 5 data compression
 - V.42 LAPM and MNP 2-4 error correction
- Fax modem with send and receive rates up to 14.4 kbps
 - V.17, V.29, V.27 ter, and V.21 channel 2 modulation modes
 - EIA/TIA 578 Class 1 and T.31 Class 1.0 commands
- Telephony/remote TAM
 - V.253 commands
 - 8-bit μ -Law/A-Law coding (G.711)
 - 8-bit/16-bit linear coding
 - 8 kHz sample rate
 - TAM support with concurrent DTMF detect, ring detect and caller ID
- V.80 synchronous access mode supports host-controlled communication protocols with H.324 interface support
- V.8/V.8bis and V.251 commands
- Data/Fax call discrimination
- Host software/MMX-based PC digital signal processing
- Worldwide operation including U.S./Japan/Canada
 - Complies to requirements of TBR21 and all other countries
 - Caller ID detection
 - Call progress, blacklisting
- Single configuration profile stored in host
- SmartDAA 3 LSD supports:
 - Digital PBX line protection
 - System side-powered DAA operates on long loops with poor line current supply conditions
 - Wake-on-Ring
 - Ring detection
 - Line polarity reversal detection
 - Line current loss detection
 - Pulse dialing
 - Line-in-use detection – detected while modem is on-hook
 - Remote hang-up detect – for efficient call termination
 - Extension pickup detect
 - Call waiting detection
 - Meets worldwide DC Voltage/Current (VI) Masks requirements

NOTES

© 2001, 2002 Conexant Systems, Inc.
All Rights Reserved.

Information in this document is provided in connection with Conexant Systems, Inc. ("Conexant") products. These materials are provided by Conexant as a service to its customers and may be used for informational purposes only. Conexant assumes no responsibility for errors or omissions in these materials. Conexant may make changes to specifications and product descriptions at any time, without notice. Conexant makes no commitment to update the information and shall have no responsibility whatsoever for conflicts or incompatibilities arising from future changes to its specifications and product descriptions.

No license, express or implied, by estoppel or otherwise, to any intellectual property rights is granted by this document. Except as provided in Conexant's Terms and Conditions of Sale for such products, Conexant assumes no liability whatsoever.

THESE MATERIALS ARE PROVIDED "AS IS" WITHOUT WARRANTY OF ANY KIND, EITHER EXPRESS OR IMPLIED, RELATING TO SALE AND/OR USE OF CONEXANT PRODUCTS INCLUDING LIABILITY OR WARRANTIES RELATING TO FITNESS FOR A PARTICULAR PURPOSE, CONSEQUENTIAL OR INCIDENTAL DAMAGES, MERCHANTABILITY, OR INFRINGEMENT OF ANY PATENT, COPYRIGHT OR OTHER INTELLECTUAL PROPERTY RIGHT. CONEXANT FURTHER DOES NOT WARRANT THE ACCURACY OR COMPLETENESS OF THE INFORMATION, TEXT, GRAPHICS OR OTHER ITEMS CONTAINED WITHIN THESE MATERIALS. CONEXANT SHALL NOT BE LIABLE FOR ANY SPECIAL, INDIRECT, INCIDENTAL, OR CONSEQUENTIAL DAMAGES, INCLUDING WITHOUT LIMITATION, LOST REVENUES OR LOST PROFITS, WHICH MAY RESULT FROM THE USE OF THESE MATERIALS.

Conexant products are not intended for use in medical, lifesaving or life sustaining applications. Conexant customers using or selling Conexant products for use in such applications do so at their own risk and agree to fully indemnify Conexant for any damages resulting from such improper use or sale.

The following are trademarks of Conexant Systems, Inc.: Conexant™, the Conexant C symbol, "What's Next in Communications Technologies"™, SmartDAA™, and K56flex™. Product names or services listed in this publication are for identification purposes only, and may be trademarks of third parties. Third-party brands and names are the property of their respective owners.

For additional disclaimer information, please consult Conexant's Legal Information posted at www.conexant.com, which is incorporated by reference.

Reader Response: Conexant strives to produce quality documentation and welcomes your feedback. Please send comments and suggestions to tech.pubs@conexant.com. For technical questions, contact your local Conexant sales office or field applications engineer.

www.conexant.com

General Information:

U.S. and Canada: (800) 854-8099

International: (949) 483-6996

Headquarters – Newport Beach

4311 Jamboree Rd.

Newport Beach, CA. 92660-3007



CONEXANT
What's next in communications technologies.