

High Power DP3T Switch with Logic Control

Description

The CXG1126EN is a high power DP3T switch MMIC. This IC can be used in wireless communication systems, for example, CDMA handsets with GPS. The CXG1126EN can be operated by the CMOS control. The Sony's GaAs JFET process is used for low insertion loss and on-chip logic circuit.

Features

- Low insertion loss: 0.25dB @900MHz,
0.35dB @1.5GHz
- High linearity: IIP3 (Typ.) = 70dBm
- 1 CMOS compatible control line
- Small package size: 10-pin VSON

Applications

- Dual-band cellular handsets
- CMDA with GPS, dual-band CDMA

Structure

GaAs J-FET MMIC

Absolute Maximum Ratings (Ta = 25°C)

• Bias voltage	V _{DD}	7	V
• Control voltage	V _{ctl}	5	V
• Operating temperature	T _{opr}	-35 to +85	°C
• Storage temperature	T _{stg}	-65 to +150	°C

10 pin VSON (Plastic)

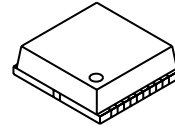

GaAs MMICs are ESD sensitive devices. Special handling precautions are required.

Sony reserves the right to change products and specifications without prior notice. This information does not convey any license by any implication or otherwise under any patents or other right. Application circuits shown, if any, are typical examples illustrating the operation of the devices. Sony cannot assume responsibility for any problems arising out of the use of these circuits.

Block Diagram and Recommended Circuit

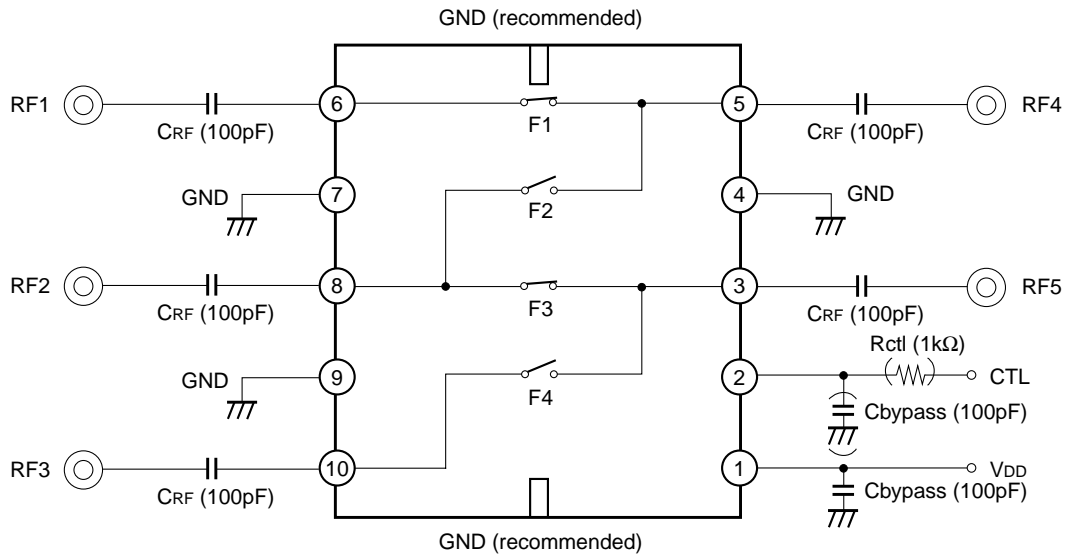

When using this IC, the following external components should be used:

- Rctl: This resistor is used to improve ESD performance. 1kΩ is recommended.
- CRF: This capacitor is used for RF de-coupling and must be used for all application. 100pF is recommended.
- Cbypass: This capacitor is used for DC line filtering. 100pF is recommended.

Truth Table

CTL	On Pass	F1	F2	F3	F4
L	RF1 – RF4, RF2 – RF5	ON	OFF	ON	OFF
H	RF2 – RF4, RF3 – RF5	OFF	ON	OFF	ON

DC Bias Condition

(Ta = 25°C)

Item	Min.	Typ.	Max.	Unit
Vctl (H)	2.0	3.0	3.6	V
Vctl (L)	0	—	0.4	V
VDD	2.6	3.0	3.6	V

Electrical Characteristics

(Ta = 25°C)

Item	Symbol	Condition	Min.	Typ.	Max.	Unit
Insertion loss	IL	RF1 – RF4 @900MHz		0.25	0.50	dB
		RF1 – RF4 @1.5GHz		0.35	0.60	dB
		RF2 – RF4 @900MHz		0.40	0.65	dB
		RF2 – RF4 @1.5GHz		0.50	0.75	dB
		RF2 – RF5 @900MHz		0.40	0.65	dB
		RF2 – RF5 @1.5GHz		0.50	0.75	dB
		RF3 – RF5 @900MHz		0.25	0.50	dB
		RF3 – RF5 @1.5GHz		0.35	0.60	dB
Isolation	ISO.	RF1 – RF4 @900MHz	18	21		dB
		RF1 – RF4 @1.5GHz	15	18		dB
		RF2 – RF4 @900MHz	27	30		dB
		RF2 – RF4 @1.5GHz	22	25		dB
		RF2 – RF5 @900MHz	27	30		dB
		RF2 – RF5 @1.5GHz	22	25		dB
		RF3 – RF5 @900MHz	18	21		dB
		RF3 – RF5 @1.5GHz	15	18		dB
VSWR	VSWR	900MHz, 1.5GHz		1.2		—
Harmonics	2fo	*1	-60	-75		dBc
	3fo	*1	-60	-75		dBc
1dB compression input power	P1dB	V _{DD} = 3.0V		34		dBm
Input IP3	IIP3	*2	60	70		dBm
Switching speed	TSW			2		μs
Control current	I _{ctl}	V _{ctl} (High) =3V		35	70	μA
Bias current	I _{DD}	V _{DD} = 3V		90	150	μA

V_{ctl} (L) = 0V, V_{ctl} (H) = 3.0V

*1 Pin = 29dBm, 900MHz, V_{DD} = 3.0V

*2 Pin = 25dBm (900MHz) + 25dBm (901MHz), V_{DD} = 3.0V

Package Outline Unit: mm

10PIN VSON(PLASTIC)

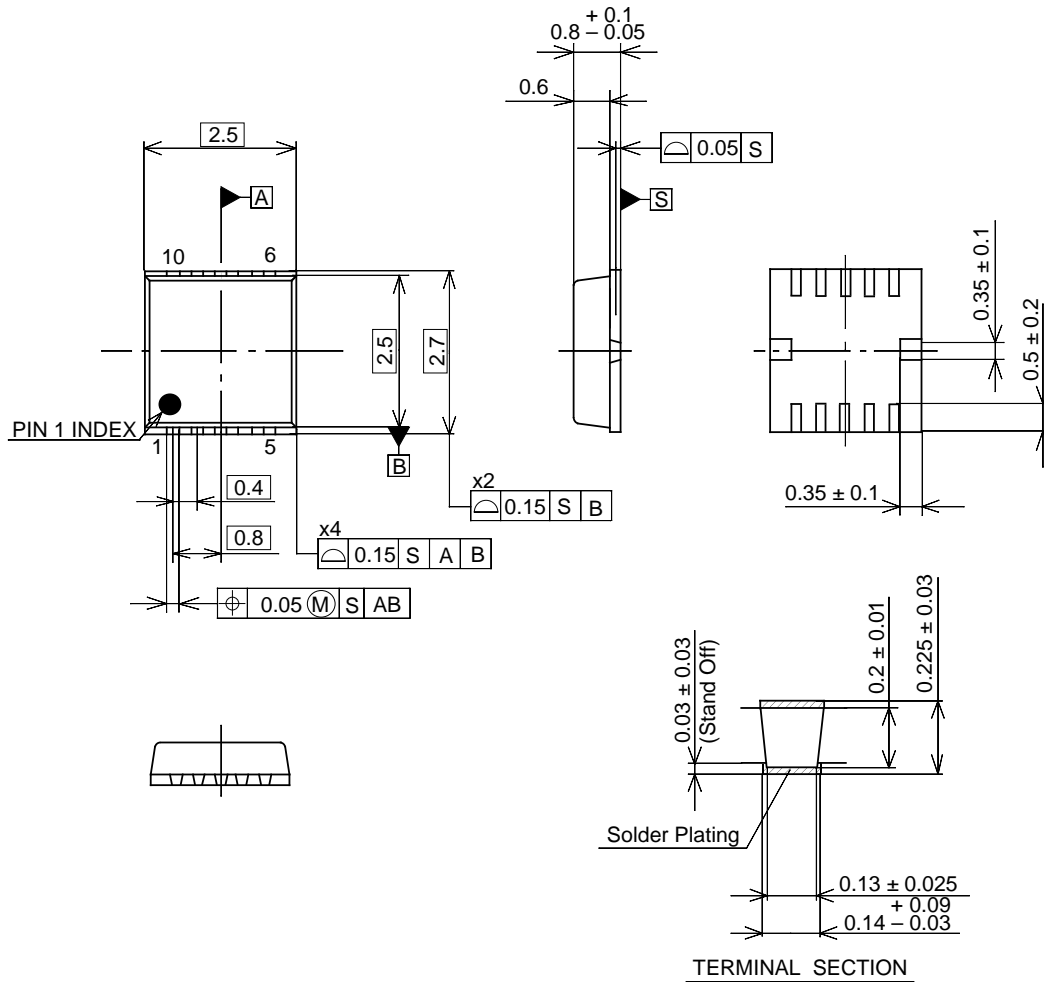

NOTE: 1) The dimensions of the terminal section apply to the ranges of 0.1mm and 0.25mm from the end of a terminal.

PACKAGE STRUCTURE

SONY CODE	VSON-10P-01
EIAJ CODE	_____
JEDEC CODE	_____

PACKAGE MATERIAL	EPOXY RESIN
LEAD TREATMENT	SOLDER PLATING
LEAD MATERIAL	COPPER ALLOY
PACKAGE MASS	0.013g

Package Outline Unit: mm

10PIN VSON(PLASTIC)

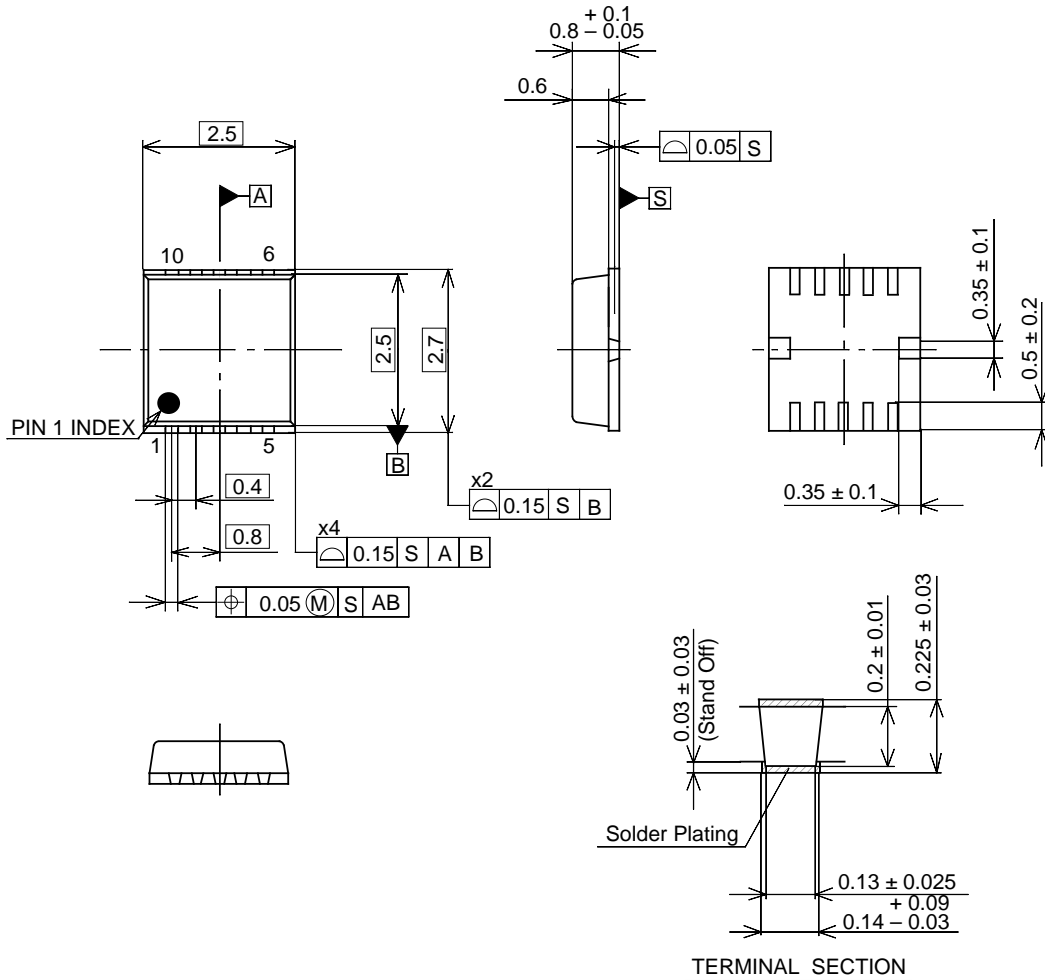

NOTE: 1) The dimensions of the terminal section apply to the ranges of 0.1mm and 0.25mm from the end of a terminal.

PACKAGE STRUCTURE

PACKAGE MATERIAL	EPOXY RESIN
LEAD TREATMENT	SOLDER PLATING
LEAD MATERIAL	COPPER ALLOY
PACKAGE MASS	0.013g

SONY CODE	VSON-10P-01
EIAJ CODE	_____
JEDEC CODE	_____

LEAD SPECIFICATIONS

ITEM	SPEC.
LEAD MATERIAL	COPPER ALLOY
LEAD TREATMENT	Sn-Bi 2.5%
LEAD TREATMENT THICKNESS	5-18µm