



CY7C1360A
CY7C1362A

256K x 36/512K x 18 Synchronous Pipelined Burst SRAM

Features

- **Fast access times: 2.5 ns, 3.0 ns, and 3.5 ns**
- **Fast clock speed: 225, 200, 166, and 150 MHz**
- **Fast OE access times: 2.5 ns, 3.0 ns, and 3.5 ns**
- **Optimal for depth expansion (one cycle chip deselect to eliminate bus contention)**
- **3.3V –5% and +10% power supply**
- **3.3V or 2.5V I/O supply**
- **5V-tolerant inputs except I/Os**
- **Clamp diodes to V_{SS} at all inputs and outputs**
- **Common data inputs and data outputs**
- **Byte Write Enable and Global Write control**
- **Multiple chip enables for depth expansion: three chip enables for A package version and two chip enables for BG and AJ package versions**
- **Address pipeline capability**
- **Address, data, and control registers**
- **Internally self-timed Write Cycle**
- **Burst control pins (interleaved or linear burst sequence)**
- **Automatic power-down feature available using ZZ mode or CE deselect**
- **JTAG boundary scan for BG and AJ package version**
- **Low-profile 119-bump, 14-mm x 22-mm PBGA (Ball Grid Array) and 100-pin TQFP packages**

Functional Description

The Cypress Synchronous Burst SRAM family employs high-speed, low-power CMOS designs using advanced triple-layer polysilicon, double-layer metal technology. Each memory cell consists of four transistors and two high-valued resistors.

The CY7C1360A and CY7C1362A SRAMs integrate 262,144 x 36 and 524,288 x 18 SRAM cells with advanced

synchronous peripheral circuitry and a two-bit counter for internal burst operation. All synchronous inputs are gated by registers controlled by a positive-edge-triggered Clock Input (CLK). The synchronous inputs include all addresses, all data inputs, address-pipelining Chip Enable (\overline{CE}), depth-expansion Chip Enables (CE_2 and \overline{CE}_3), burst control inputs (\overline{ADSC} , \overline{ADSP} , and \overline{ADV}), Write Enables (BW_a , BW_b , BW_c , BW_d , and BW_e), and global Write (\overline{GW}). However, the \overline{CE}_3 chip enable input is only available for the TA package version.

Asynchronous inputs include the Output Enable (\overline{OE}) and burst mode control (MODE). The data outputs (Q), enabled by OE, are also asynchronous.

Addresses and chip enables are registered with either Address Status Processor (\overline{ADSP}) or Address Status Controller (\overline{ADSC}) input pins. Subsequent burst addresses can be internally generated as controlled by the Burst Advance Pin (\overline{ADV}).

Address, data inputs, and Write controls are registered on-chip to initiate self-timed Write cycle. Write cycles can be one to four bytes wide as controlled by the Write control inputs. Individual byte Write allows individual byte to be written. BW_a controls DQ_a . BW_b controls DQ_b . BW_c controls DQ_c . BW_d controls DQ_d . BW_e , BW_b , BW_c , and BW_d can be active only with BW_e being LOW. \overline{GW} being LOW causes all bytes to be written. The x18 version only has 18 data inputs/outputs (DQ_a and DQ_b) along with BW_a and BW_b (no BW_c , BW_d , DQ_c , and DQ_d).

For the B and T package versions, four pins are used to implement JTAG test capabilities: Test Mode Select (TMS), Test Data-In (TDI), Test Clock (TCK), and Test Data-Out (TDO). The JTAG circuitry is used to serially shift data to and from the device. JTAG inputs use LVTTTL/LVCMOS levels to shift data during this testing mode of operation. The TA package version does not offer the JTAG capability.

The CY7C1360A and CY7C1362A operate from a +3.3V power supply. All inputs and outputs are LVTTTL-compatible.

Selection Guide

	7C1360A-225 7C1362A-225	7C1360A-200 7C1362A-200	7C1360A-166 7C1362A-166	7C1360A-150 7C1362A-150	Unit
Maximum Access Time	2.5	3.0	3.5	3.5	ns
Maximum Operating Current	650	620	530	480	mA
Maximum CMOS Standby Current	10	10	10	10	mA

Functional Block Diagram—256K x 36^[1]

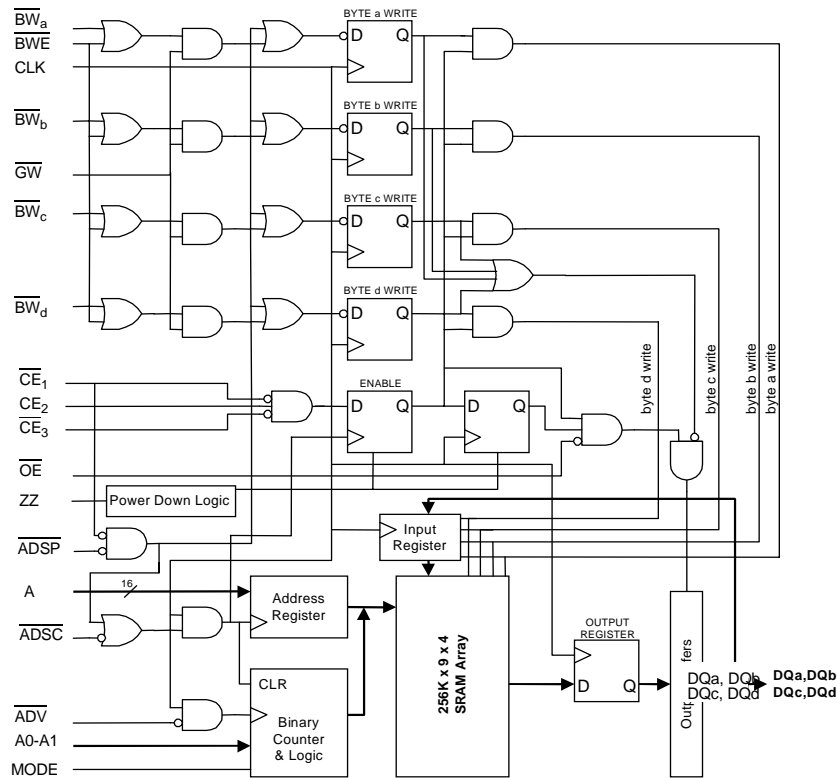

Functional Block Diagram—512K x 18^[1]

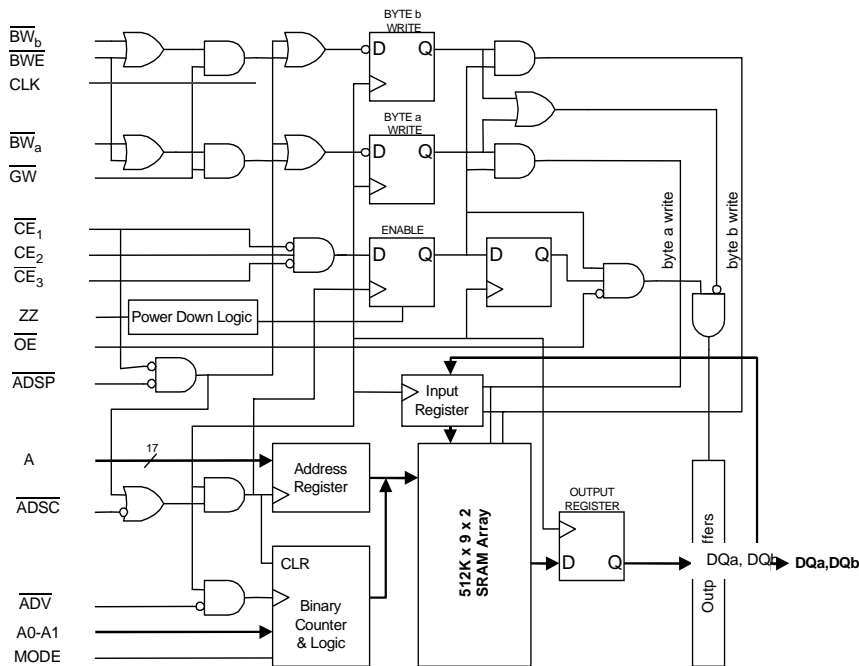

Notes:

1. The Functional Block Diagram illustrates simplified device operation. See Truth Table, pin descriptions, and timing diagrams for detailed information.
2. CE₃ is for TA version only.



Pin Configurations

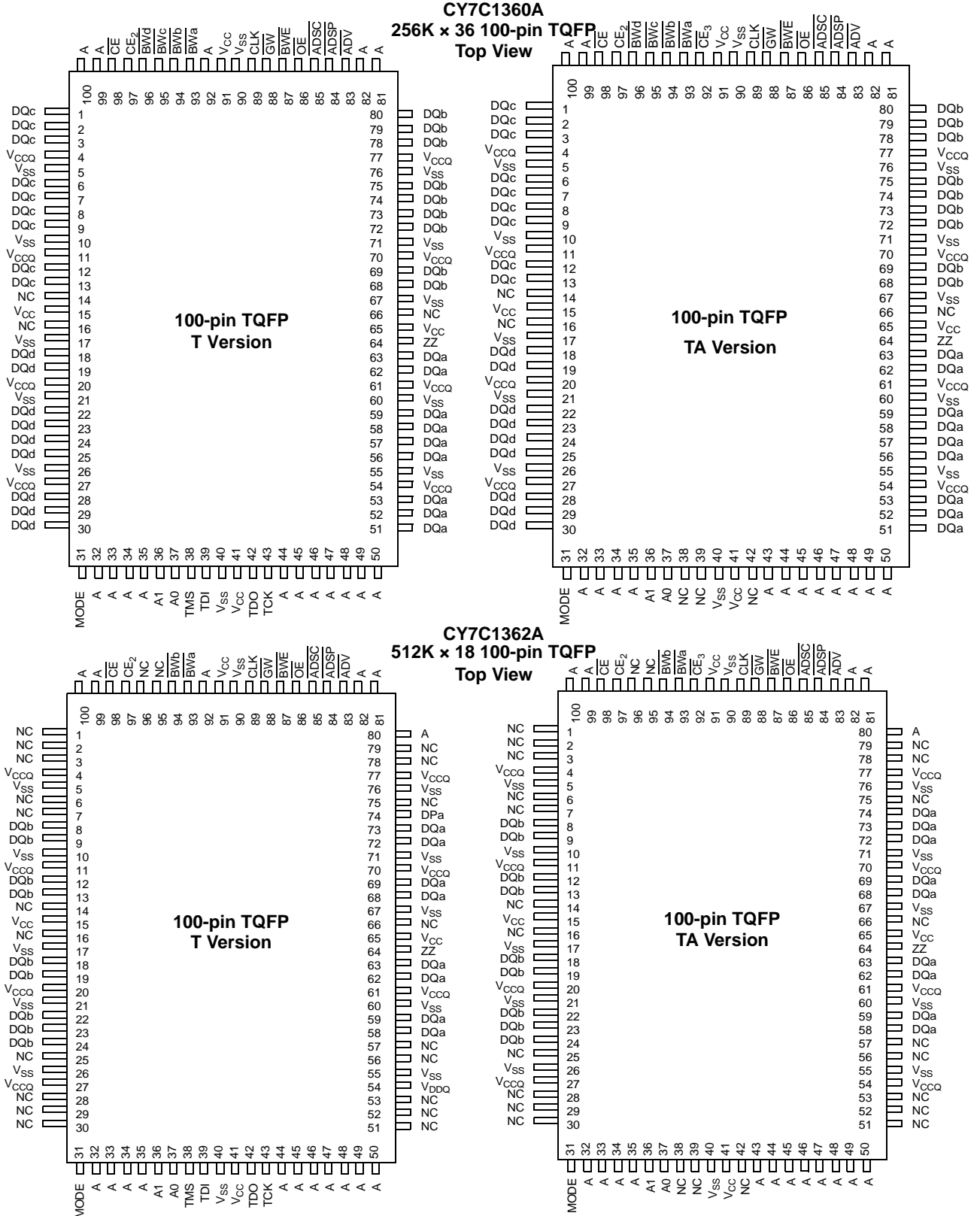



Pin Configurations (continued)

CY7C1360A 256K x 36 119-ball BGA Top View

	1	2	3	4	5	6	7
A	V _{CCQ}	A	A	ADSP	A	A	V _{CCQ}
B	NC	CE ₂	A	ADSC	A	A	NC
C	NC	A	A	V _{CC}	A	A	NC
D	DQc	DQc	V _{SS}	NC	V _{SS}	DQb	DQb
E	DQc	DQc	V _{SS}	CE	V _{SS}	DQb	DQb
F	V _{CCQ}	DQc	V _{SS}	OE	V _{SS}	DQb	V _{CCQ}
G	DQc	DQc	BWc	ADV	BWb	DQb	DQb
H	DQc	DQc	V _{SS}	GW	V _{SS}	DQb	DQb
J	V _{CCQ}	V _{CC}	NC	V _{CC}	NC	V _{CC}	V _{CCQ}
K	DQd	DQd	V _{SS}	CLK	V _{SS}	DQa	DQa
L	DQd	DQd	BWd	NC	BWa	DQa	DQa
M	V _{CCQ}	DQd	V _{SS}	BWE	V _{SS}	DQa	V _{CCQ}
N	DQd	DQd	V _{SS}	A1	V _{SS}	DQa	DQa
P	DQd	DQd	V _{SS}	A0	V _{SS}	DQa	DQa
R	NC	A	MODE	V _{CC}	NC	A	NC
T	NC	NC	A	A	A	NC	ZZ
U	V _{CCQ}	TMS	TDI	TCK	TDO	NC	V _{CCQ}

CY7C1362A 512K x 18 119-ball BGA Top View

	1	2	3	4	5	6	7
A	V _{CCQ}	A	A	ADSP	A	A	V _{CCQ}
B	NC	CE ₂	A	ADSC	A	CE ₃	NC
C	NC	A	A	V _{CC}	A	A	NC
D	DQb	NC	V _{SS}	NC	V _{SS}	DQa	NC
E	NC	DQb	V _{SS}	CE	V _{SS}	NC	DQa
F	V _{CCQ}	NC	V _{SS}	OE	V _{SS}	DQa	V _{CCQ}
G	NC	DQb	BWb	ADV	V _{SS}	NC	DQa
H	DQb	NC	V _{SS}	GW	V _{SS}	DQa	NC
J	V _{CCQ}	V _{CC}	NC	V _{CC}	NC	V _{CC}	V _{CCQ}
K	NC	DQb	V _{SS}	CLK	V _{SS}	NC	DQa
L	DQb	NC	V _{SS}	NC	BWa	DQa	NC
M	V _{CCQ}	DQb	V _{SS}	BWE	V _{SS}	NC	V _{CCQ}
N	DQb	NC	V _{SS}	A1	V _{SS}	DQa	NC
P	NC	DQb	V _{SS}	A0	V _{SS}	NC	DQa
R	NC	A	MODE	V _{CC}	NC	A	NC
T	NC	A	A	NC	A	A	ZZ
U	V _{CCQ}	TMS	TDI	TCK	TDO	NC	V _{CCQ}



256K x 36 Pin Descriptions

X36 PBGA Pins	X36 QFP Pins	Name	Type	Description
4P 4N 2A, 3A, 5A, 6A, 3B, 5B, 6B, 2C, 3C, 5C, 6C, 2R, 6R, 3T, 4T, 5T	37 36 35, 34, 33, 32, 100, 99, 82, 81, 44, 45, 46, 47, 48, 49, 50 92 (T/AJ Version) 43 (TA/A Version)	A0 A1 A	Input- Synchronous	Addresses: These inputs are registered and must meet the set-up and hold times around the rising edge of CLK. The burst counter generates internal addresses associated with A0 and A1, during burst cycle and wait cycle.
5L 5G 3G 3L	93 94 95 96	\overline{BWA} \overline{BWB} \overline{BWC} \overline{BWD}	Input- Synchronous	Byte Write: A byte Write is LOW for a Write cycle and HIGH for a Read cycle. \overline{BWA} controls DQa. \overline{BWB} controls DQb. \overline{BWC} controls DQc. \overline{BWD} controls DQd. Data I/O are high impedance if either of these inputs are LOW, conditioned by \overline{BWE} being LOW.
4M	87	\overline{BWE}	Input- Synchronous	Write Enable: This active LOW input gates byte Write operations and must meet the set-up and hold times around the rising edge of CLK.
4H	88	GW	Input- Synchronous	Global Write: This active LOW input allows a full 36-bit Write to occur independent of the \overline{BWE} and \overline{BWN} lines and must meet the set-up and hold times around the rising edge of CLK.
4K	89	CLK	Input- Synchronous	Clock: This signal registers the addresses, data, chip enables, Write control, and burst control inputs on its rising edge. All synchronous inputs must meet set-up and hold times around the clock's rising edge.
4E	98	CE	Input- Synchronous	Chip Enable: This active LOW input is used to enable the device and to gate ADSP.
2B	97	CE ₂	Input- Synchronous	Chip Enable: This active HIGH input is used to enable the device.
– (not available for PBGA)	92 (for TA/A version only)	CE ₃	Input- Synchronous	Chip Enable: This active LOW input is used to enable the device. Not available for B and T package versions.
4F	86	\overline{OE}	Input	Output Enable: This active LOW asynchronous input enables the data output drivers.
4G	83	ADV	Input- Synchronous	Address Advance: This active LOW input is used to control the internal burst counter. A HIGH on this pin generates wait cycle (no address advance).
4A	84	ADSP	Input- Synchronous	Address Status Processor: This active LOW input, along with CE being LOW, causes a new external address to be registered and a Read cycle is initiated using the new address.
4B	85	ADSC	Input- Synchronous	Address Status Controller: This active LOW input causes the device to be deselected or selected along with new external address to be registered. A Read or Write cycle is initiated depending upon Write control inputs.
3R	31	MODE	Input- Static	Mode: This input selects the burst sequence. A LOW on this pin selects Linear Burst. A NC or HIGH on this pin selects Interleaved Burst.
7T	64	ZZ	Input- Asynchronous	Sleep: This active HIGH input puts the device in low power consumption standby mode. For normal operation, this input has to be either LOW or NC (No Connect).



256K x 36 Pin Descriptions (continued)

X36 PBGA Pins	X36 QFP Pins	Name	Type	Description
(a) 6P, 7P, 7N, 6N, 6M, 6L, 7L, 6K, 7K, (b) 7H, 6H, 7G, 6G, 6F, 6E, 7E, 7D, 6D, (c) 2D, 1D, 1E, 2E, 2F, 1G, 2G, 1H, 2H, (d) 1K, 2K, 1L, 2L, 2M, 1N, 2N, 1P, 2P	(a) 51, 52, 53, 56, 57, 58, 59, 62, 63 (b) 68, 69, 72, 73, 74, 75, 78, 79, 80 (c) 1, 2, 3, 6, 7, 8, 9, 12, 13 (d) 18, 19, 22, 23, 24, 25, 28, 29, 30	DQa DQb DQc DQd	Input/ Output	Data Inputs/Outputs: First Byte is DQa. Second Byte is DQb. Third Byte is DQc. Fourth Byte is DQd. Input data must meet set-up and hold times around the rising edge of CLK.
2U 3U 4U	38 39 43 for BG/B and T/AJ version	TMS TDI TCK	Input	IEEE 1149.1 test inputs. LVTTTL-level inputs. Not available for TA/A package version.
5U	42 for BG/B and T/AJ version	TDO	Output	IEEE 1149.1 test output. LVTTTL-level output. Not available for TA package version.
4C, 2J, 4J, 6J, 4R	15, 41, 65, 91	V _{CC}	Power Supply	Core power supply: +3.3V -5% and +10%
3D, 5D, 3E, 5E, 3F, 5F, 3H, 5H, 3K, 5K, 3M, 5M, 3N, 5N, 3P, 5P	5, 10, 17, 21, 26, 40, 55, 60, 67, 71, 76, 90	V _{SS}	Ground	Ground: GND.
1A, 7A, 1F, 7F, 1J, 7J, 1M, 7M, 1U, 7U	4, 11, 20, 27, 54, 61, 70, 77	V _{CCQ}	I/O Power Supply	Power Supply for the I/O circuitry
1B, 7B, 1C, 7C, 4D, 3J, 5J, 4L, 1R, 5R, 7R, 1T, 2T, 6T, 6U	14, 16, 66 38, 39, 42 for TA/A version	NC	-	No Connect: These signals are not internally connected. User can leave it floating or connect it to V _{CC} or V _{SS} .

512K x 18 Pin Descriptions

X18 PBGA Pins	X18 QFP Pins	Name	Type	Description
4P 4N 2A, 3A, 5A, 6A, 3B, 5B, 6B, 2C, 3C, 5C, 6C, 2R, 6R, 2T, 3T, 5T, 6T	37 36 35, 34, 33, 32, 100, 99, 82, 81, 80, 48, 47, 46, 45, 44, 49, 50 92 (T/AJ Version) 43 (TA/A Version)	A0 A1 A	Input- Synchronous	Addresses: These inputs are registered and must meet the set up and hold times around the rising edge of CLK. The burst counter generates internal addresses associated with A0 and A1, during burst cycle and wait cycle.
5L 3G	93 94	BW _a BW _b	Input- Synchronous	Byte Write Enables: A byte Write enable is LOW for a Write cycle and HIGH for a Read cycle. BW _a controls DQa. BW _b controls DQb. Data I/O are high impedance if either of these inputs are LOW, conditioned by BWE being LOW.
4M	87	BWE	Input- Synchronous	Write Enable: This active LOW input gates byte Write operations and must meet the set-up and hold times around the rising edge of CLK.
4H	88	GW	Input- Synchronous	Global Write: This active LOW input allows a full 18-bit Write to occur independent of the BWE and WEn lines and must meet the set-up and hold times around the rising edge of CLK.
4K	89	CLK	Input- Synchronous	Clock: This signal registers the addresses, data, chip enables, Write control and burst control inputs on its rising edge. All synchronous inputs must meet set-up and hold times around the clock's rising edge.
4E	98	CE	Input- Synchronous	Chip Enable: This active LOW input is used to enable the device and to gate ADSP.
2B	97	CE ₂	Input- Synchronous	Chip Enable: This active HIGH input is used to enable the device.



512K x 18 Pin Descriptions (continued)

X18 PBGA Pins	X18 QFP Pins	Name	Type	Description
– (not available for PBGA)	92 (for TA/A Version only)	CE ₃	Input-Synchronous	Chip Enable: This active LOW input is used to enable the device. Not available for BG/B and T/AJ package versions.
4F	86	OE	Input	Output Enable: This active LOW asynchronous input enables the data output drivers.
4G	83	ADV	Input-Synchronous	Address Advance: This active LOW input is used to control the internal burst counter. A HIGH on this pin generates wait cycle (no address advance).
4A	84	ADSP	Input-Synchronous	Address Status Processor: This active LOW input, along with CE being LOW, causes a new external address to be registered and a Read cycle is initiated using the new address.
4B	85	ADSC	Input-Synchronous	Address Status Controller: This active LOW input causes device to be deselected or selected along with new external address to be registered. A Read or Write cycle is initiated depending upon Write control inputs.
3R	31	MODE	Input-Static	Mode: This input selects the burst sequence. A LOW on this pin selects Linear Burst. An NC or HIGH on this pin selects Interleaved Burst.
7T	64	ZZ	Input-Asynchronous	Sleep: This active HIGH input puts the device in low power consumption standby mode. For normal operation, this input has to be either LOW or NC (No Connect).
(a) 6D, 7E, 6F, 7G, 6H, 7K, 6L, 6N, 7P (b) 1D, 2E, 2G, 1H, 2K, 1L, 2M, 1N, 2P	(a) 58, 59, 62, 63, 68, 69, 72, 73, 74 (b) 8, 9, 12, 13, 18, 19, 22, 23, 24	DQa DQb	Input/Output	Data Inputs/Outputs: Low Byte is DQa. High Byte is DQb. Input data must meet set up and hold times around the rising edge of CLK.
2U 3U 4U	38 39 43 for B and T version	TMS TDI TCK	Input	IEEE 1149.1 test inputs. LVTTTL-level inputs. Not available for TA/A package version.
5U	42 for BG/B and T/AJ version	TDO	Output	IEEE 1149.1 test output. LVTTTL-level output. Not available for TA/A package version.
4C, 2J, 4J, 6J, 4R	15, 41, 65, 91	V _{CC}	Supply	Core power supply: +3.3V –5% and +10%
3D, 5D, 3E, 5E, 3F, 5F, 5G, 3H, 5H, 3K, 5K, 3L, 3M, 5M, 3N, 5N, 3P, 5P	5, 10, 17, 21, 26, 40, 55, 60, 67, 71, 76, 90	V _{SS}	Ground	Ground: GND.
1A, 7A, 1F, 7F, 1J, 7J, 1M, 7M, 1U, 7U	4, 11, 20, 27, 54, 61, 70, 77	V _{CCQ}	I/O Power Supply	Power Supply for the I/O circuitry
1B, 7B, 1C, 7C, 2D, 4D, 7D, 1E, 6E, 2F, 1G, 6G, 2H, 7H, 3J, 5J, 1K, 6K, 2L, 4L, 7L, 6M, 2N, 7N, 1P, 6P, 1R, 5R, 7R, 1T, 4T, 6U	1–3, 6, 7, 14, 16, 25, 28–30, 51–53, 56, 57, 66, 75, 78, 79, 80, 95, 96 38, 39, 42 for TA Version	NC	–	No Connect: These signals are not internally connected. User can leave it floating or connect it to V _{CC} or V _{SS} .

Introduction

Functional Overview

All synchronous inputs pass through input registers controlled by the rising edge of the clock. All data outputs pass through output registers controlled by the rising edge of the clock. Maximum access delay from the clock rise (t_{CO}) is 3.8 ns (133-MHz device).

The CY7C1360A/CY7C1362A supports secondary cache in systems utilizing either a linear or interleaved burst sequence. The interleaved burst order supports Pentium and i486 processors. The linear burst sequence is suited for processors that utilize a linear burst sequence. The burst order is user selectable, and is determined by sampling the MODE input. Accesses can be initiated with either the Processor Address Strobe (ADSP) or the Controller Address Strobe (ADSC). Address advancement through the burst sequence is controlled by the ADV input. A two-bit on-chip wraparound burst counter captures the first address in a burst sequence and automatically increments the address for the rest of the burst access.

Byte Write operations are qualified with the Byte Write Enable (BWE) and Byte Write Select ($BW_{a,b,c,d}$ for 1360A and $BW_{a,b}$ for 1362A) inputs. A Global Write Enable (GW) overrides all byte Write inputs and writes data to all four bytes. All writes are simplified with on-chip synchronous self-timed Write circuitry.

Synchronous Chip Selects ($\overline{CE}_1, CE_2, \overline{CE}_3$ for TQFP / \overline{CE}_1 for BGA) and an asynchronous Output Enable (\overline{OE}) provide for easy bank selection and output three-state control. ADSP is ignored if \overline{CE}_1 is HIGH.

Single Read Accesses

This access is initiated when the following conditions are satisfied at clock rise: (1) ADSP or ADSC is asserted LOW, (2) chip selects are all asserted active, and (3) the Write signals (GW, BWE) are all deasserted HIGH. ADSP is ignored if \overline{CE}_1 is HIGH. The address presented to the address inputs is stored into the address advancement logic and the Address Register while being presented to the memory core. The corresponding data is allowed to propagate to the input of the Output Registers. At the rising edge of the next clock the data is allowed to propagate through the output register and onto the data bus within preliminary ns (200-MHz device) if \overline{OE} is active LOW. The only exception occurs when the SRAM is emerging from a deselected state to a selected state, its outputs are always three-stated during the first cycle of the access. After the first cycle of the access, the outputs are controlled by the \overline{OE} signal. Consecutive single Read cycles are supported. Once the SRAM is deselected at clock rise by the chip select and either ADSP or ADSC signals, its output will three-state immediately.

Single Write Accesses Initiated by ADSP

This access is initiated when both of the following conditions are satisfied at clock rise: (1) ADSP is asserted LOW, and (2) chip select is asserted active. The address presented is loaded into the address register and the address advancement logic while being delivered to the RAM core. The Write signals

($\overline{GW}, \overline{BWE},$ and \overline{BW}_x) and ADV inputs are ignored during this first cycle.

ADSP triggered Write accesses require two clock cycles to complete. If GW is asserted LOW on the second clock rise, the data presented to the DQx inputs is written into the corresponding address location in the RAM core. If \overline{GW} is HIGH, then the Write operation is controlled by \overline{BWE} and \overline{BW}_x signals. The CY7C1360A/CY7C1362A provides byte Write capability that is described in the Write cycle description table. Asserting the Byte Write Enable input (BWE) with the selected Byte Write ($BW_{a,b,c,d}$ for CY7C1360A and $BW_{a,b}$ for CY7C1362A) input will selectively write to only the desired bytes. Bytes not selected during a byte Write operation will remain unaltered. A synchronous self-timed Write mechanism has been provided to simplify the Write operations.

Because the CY7C1360A/CY7C1362A is a common I/O device, the Output Enable (\overline{OE}) must be deasserted HIGH before presenting data to the DQ inputs. Doing so will three-state the output drivers. As a safety precaution, DQ are automatically three-stated whenever a Write cycle is detected, regardless of the state of \overline{OE} .

Single Write Accesses Initiated by ADSC

ADSC Write accesses are initiated when the following conditions are satisfied: (1) ADSC is asserted LOW, (2) ADSP is deasserted HIGH, (3) chip select is asserted active, and (4) the appropriate combination of the Write inputs ($\overline{GW}, \overline{BWE},$ and \overline{BW}_x) are asserted active to conduct a Write to the desired byte(s). ADSC triggered Write accesses require a single clock cycle to complete. The address presented to $A_{[17:0]}$ is loaded into the address register and the address advancement logic while being delivered to the RAM core. The ADV input is ignored during this cycle. If a global Write is conducted, the data presented to the $DQ_{[x:0]}$ is written into the corresponding address location in the RAM core. If a byte Write is conducted, only the selected bytes are written. Bytes not selected during a byte Write operation will remain unaltered. A synchronous self-timed Write mechanism has been provided to simplify the Write operations.

Because the CY7C1360A/CY7C1362A is a common I/O device, the Output Enable (\overline{OE}) must be deasserted HIGH before presenting data to the $DQ_{[x:0]}$ inputs. Doing so will three-state the output drivers. As a safety precaution, $DQ_{[x:0]}$ are automatically three-stated whenever a Write cycle is detected, regardless of the state of \overline{OE} .

Burst Sequences

The CY7C1360A/CY7C1362A provides a two-bit wraparound counter, fed by $A_{[1:0]}$, that implements either an interleaved or linear burst sequence. The interleaved burst sequence is designed specifically to support Intel® Pentium® applications. The linear burst sequence is designed to support processors that follow a linear burst sequence. The burst sequence is user selectable through the MODE input.

Asserting ADV LOW at clock rise will automatically increment the burst counter to the next address in the burst sequence. Both Read and Write burst operations are supported.



Burst Address Table (MODE = NC/V_{CC})

First Address (external)	Second Address (internal)	Third Address (internal)	Fourth Address (internal)
A _[1:0]]	A _[1:0]	A _[1:0]	A _[1:0]
00	01	10	11
01	00	11	10
10	11	00	01
11	10	01	00

Burst Address Table (MODE = GND)

First Address (external)	Second Address (internal)	Third Address (internal)	Fourth Address (internal)
A _[1:0]]	A _[1:0]	A _[1:0]	A _[1:0]
00	01	10	11
01	10	11	00
10	11	00	01
11	00	01	10

Truth Table^[3, 4, 5, 6, 7, 8, 9]

Next Cycle	Address Used	ZZ	CE ₃	CE ₂	CE ₁	ADSP	ADSC	ADV	OE	DQ	DQ
Unselected	None	0	X	X	1	X	0	X	X	Hi-Z	X
Unselected	None	0	1	X	0	0	X	X	X	Hi-Z	X
Unselected	None	0	X	0	0	0	X	X	X	Hi-Z	X
Unselected	None	0	1	X	0	1	0	X	X	Hi-Z	X
Unselected	None	0	X	0	0	1	0	X	X	Hi-Z	X
Begin Read	External	0	0	1	0	0	X	X	X	Hi-Z	X
Begin Read	External	0	0	1	0	1	0	X	X	Hi-Z	Read
Continue Read	Next	0	X	X	X	1	1	0	1	Hi-Z	Read
Continue Read	Next	0	X	X	X	1	1	0	0	DQ	Read
Continue Read	Next	0	X	X	1	X	1	0	1	Hi-Z	Read
Continue Read	Next	0	X	X	1	X	1	0	0	DQ	Read
Suspend Read	Current	0	X	X	X	1	1	1	1	Hi-Z	Read
Suspend Read	Current	0	X	X	X	1	1	1	0	DQ	Read
Suspend Read	Current	0	X	X	1	X	1	1	1	Hi-Z	Read
Suspend Read	Current	0	X	X	1	X	1	1	0	DQ	Read
Begin Write	Current	0	X	X	X	1	1	1	X	Hi-Z	Write
Begin Write	Current	0	X	X	1	X	1	1	X	Hi-Z	Write
Begin Write	External	0	0	1	0	1	0	X	X	Hi-Z	Write
Continue Write	Next	0	X	X	X	1	1	0	X	Hi-Z	Write
Continue Write	Next	0	X	X	1	X	1	0	X	Hi-Z	Write
Suspend Write	Current	0	X	X	X	1	1	1	X	Hi-Z	Write
Suspend Write	Current	0	X	X	1	X	1	1	X	Hi-Z	Write
ZZ "sleep"	None	1	X	X	X	X	X	X	X	Hi-Z	X

Notes:

- X = "Don't Care." H = logic HIGH. L = logic LOW.
For X36 product, Write = L means $[BWE + BWa \cdot BWb \cdot BWc \cdot Bwd] \cdot GW$ equals LOW. Write = H means $[BWE + BWa \cdot BWb \cdot BWc \cdot Bwd] \cdot GW$ equals HIGH.
For X18 product, Write = L means $[BWE + BWa \cdot BWb] \cdot GW$ equals LOW. Write = H means $[BWE + BWa \cdot BWb] \cdot GW$ equals HIGH.
- BWa enables Write to DQa. BWb enables Write to DQb. BWc enables Write to DQc. Bwd enables Write to DQd.
- All inputs except OE must meet set-up and hold times around the rising edge (LOW to HIGH) of CLK.
- Suspending burst generates wait cycle.
- For a Write operation following a Read operation, \overline{OE} must be HIGH before the input-data-required set-up time plus High-Z time for \overline{OE} and staying HIGH throughout the input data hold time.
- This device contains circuitry that will ensure the outputs will be in High-Z during power-up.
- ADSP LOW along with chip being selected always initiates a Read cycle at the L-H edge of CLK. A Write cycle can be performed by setting \overline{Write} LOW for the CLK L-H edge of the subsequent wait cycle. Refer to Write timing diagram for clarification.



Partial Truth Table for Read/Write^[10]

Function (1360A)	GW	BWE	BWd	BWc	BWb	BWa
Read	1	1	X	X	X	X
Read	1	0	1	1	1	1
Write Byte 0 – DQa	1	0	1	1	1	0
Write Byte 1 – DQb	1	0	1	1	0	1
Write Bytes 1, 0	1	0	1	1	0	0
Write Byte 2 – DQc	1	0	1	0	1	1
Write Bytes 2, 0	1	0	1	0	1	0
Write Bytes 2, 1	1	0	1	0	0	1
Write Bytes 2, 1, 0	1	0	1	0	0	0
Write Byte 3 – DQd	1	0	0	1	1	1
Write Bytes 3, 0	1	0	0	1	1	0
Write Bytes 3, 1	1	0	0	1	0	1
Write Bytes 3, 1, 0	1	0	0	1	0	0
Write Bytes 3, 2	1	0	0	0	1	1
Write Bytes 3, 2, 0	1	0	0	0	1	0
Write Bytes 3, 2, 1	1	0	0	0	0	1
Write All Bytes	1	0	0	0	0	0
Write All Bytes	0	X	X	X	X	X

Function (1362A)	GW	BWE	BWb	BWa
Read	1	1	X	X
Read	1	0	1	1
Write Byte 0 – DQ _[7:0] and DP ₀	1	0	1	0
Write Byte 1 – DQ _[15:8] and DP ₁	1	0	0	1
Write All Bytes	1	0	0	0
Write All Bytes	0	X	X	X

Sleep Mode

The ZZ input pin is an asynchronous input. Asserting ZZ places the SRAM in a power conservation “sleep” mode. Two clock cycles are required to enter into or exit from this “sleep” mode. While in this mode, data integrity is guaranteed.

Accesses pending when entering the “sleep” mode are not considered valid nor is the completion of the operation guaranteed. The device must be deselected prior to entering the “sleep” mode. CEs, ADSP, and ADSC must remain inactive for the duration of t_{ZZREC} after the ZZ input returns LOW.

ZZ Mode Electrical Characteristics

Parameter	Description	Test Conditions	Min.	Max.	Unit
I _{DDZZ}	Sleep mode standby current	ZZ ≥ V _{DD} – 0.2V		10	mA
t _{ZZS}	Device operation to ZZ	ZZ ≥ V _{DD} – 0.2V		2t _{CYC}	ns
t _{ZZREC}	ZZ recovery time	ZZ ≤ 0.2V	2t _{CYC}		ns

Note:

10. For the X18 product, there are only \overline{BWA} and \overline{BWB} .

IEEE 1149.1 Serial Boundary Scan (JTAG)

Overview

This device incorporates a serial boundary scan access port (TAP). This port is designed to operate in a manner consistent with IEEE Standard 1149.1-1990 (commonly referred to as JTAG), but does not implement all of the functions required for IEEE 1149.1 compliance. Certain functions have been modified or eliminated because their implementation places extra delays in the critical speed path of the device. Nevertheless, the device supports the standard TAP controller architecture (the TAP controller is the state machine that controls the TAPs operation) and can be expected to function in a manner that does not conflict with the operation of devices with IEEE Standard 1149.1-compliant TAPs. The TAP operates using LVTTTL/LVCMOS logic level signaling.

Disabling the JTAG Feature

It is possible to use this device without using the JTAG feature. To disable the TAP controller without interfering with normal operation of the device, TCK should be tied LOW (V_{SS}) to prevent clocking the device. TDI and TMS are internally pulled up and may be unconnected. They may alternately be pulled up to V_{CC} through a resistor. TDO should be left unconnected. Upon power-up the device will come up in a reset state which will not interfere with the operation of the device.

Test Access Port

TCK—Test Clock (INPUT)

Clocks all TAP events. All inputs are captured on the rising edge of TCK and all outputs propagate from the falling edge of TCK.

TMS—Test Mode Select (INPUT)

The TMS input is sampled on the rising edge of TCK. This is the command input for the TAP controller state machine. It is allowable to leave this pin unconnected if the TAP is not used. The pin is pulled up internally, resulting in a logic HIGH level.

TDI—Test Data In (INPUT)

The TDI input is sampled on the rising edge of TCK. This is the input side of the serial registers placed between TDI and TDO. The register placed between TDI and TDO is determined by the state of the TAP controller state machine and the instruction that is currently loaded in the TAP instruction register (refer to *Figure 1*, TAP Controller State Diagram). It is allowable to leave this pin unconnected if it is not used in an application. The pin is pulled up internally, resulting in a logic HIGH level. TDI is connected to the Most Significant Bit (MSB) of any register (see *Figure 2*).

TDO—Test Data Out (OUTPUT)

The TDO output pin is used to serially clock data-out from the registers. The output that is active depending on the state of the TAP state machine (refer to *Figure 1*, TAP Controller State Diagram). Output changes in response to the falling edge of TCK. This is the output side of the serial registers placed between TDI and TDO. TDO is connected to the Least Significant Bit (LSB) of any register (see *Figure 2*).

Performing a TAP Reset

The TAP circuitry does not have a reset pin (\overline{TRST} , which is optional in the IEEE 1149.1 specification). A RESET can be performed for the TAP controller by forcing TMS HIGH (V_{CC}) for five rising edges of TCK and pre-loads the instruction register with the IDCODE command. This type of reset does not affect the operation of the system logic. The reset affects test logic only.

At power-up, the TAP is reset internally to ensure that TDO is in a High-Z state.

TAP Registers

Overview

The various TAP registers are selected (one at a time) via the sequences of ones and zeros input to the TMS pin as the TCK is strobed. Each of the TAPs registers are serial shift registers that capture serial input data on the rising edge of TCK and push serial data out on subsequent falling edge of TCK. When a register is selected, it is connected between the TDI and TDO pins.

Instruction Register

The instruction register holds the instructions that are executed by the TAP controller when it is moved into the run test/idle or the various data register states. The instructions are three bits long. The register can be loaded when it is placed between the TDI and TDO pins. The parallel outputs of the instruction register are automatically preloaded with the IDCODE instruction upon power-up or whenever the controller is placed in the test-logic reset state. When the TAP controller is in the Capture-IR state, the two LSBs of the serial instruction register are loaded with a binary "01" pattern to allow for fault isolation of the board-level serial test data path.

Bypass Register

The bypass register is a single-bit register that can be placed between TDI and TDO. It allows serial test data to be passed through the device TAP to another device in the scan chain with minimum delay. The bypass register is set LOW (V_{SS}) when the BYPASS instruction is executed.

Boundary Scan Register

The Boundary Scan register is connected to all the input and bidirectional I/O pins (not counting the TAP pins) on the device. This also includes a number of NC pins that are reserved for future needs. There are a total of 70 bits for the x36 device and 51 bits for the x18 device. The boundary scan register, under the control of the TAP controller, is loaded with the contents of the device I/O ring when the controller is in Capture-DR state and then is placed between the TDI and TDO pins when the controller is moved to Shift-DR state. The EXTEST, SAMPLE/PRELOAD and SAMPLE-Z instructions can be used to capture the contents of the I/O ring.

The Boundary Scan Order table describes the order in which the bits are connected. The first column defines the bit's position in the boundary scan register. The MSB of the register is connected to TDI, and LSB is connected to TDO. The second column is the signal name, the third column is the TQFP pin number, and the fourth column is the BGA bump number.

Identification (ID) Register

The ID Register is a 32-bit register that is loaded with a device and vendor specific 32-bit code when the controller is put in Capture-DR state with the IDCODE command loaded in the instruction register. The register is then placed between the TDI and TDO pins when the controller is moved into Shift-DR state. Bit 0 in the register is the LSB and the first to reach TDO when shifting begins. The code is loaded from a 32-bit on-chip ROM. It describes various attributes of the device as described in the Identification Register Definitions table.

TAP Controller Instruction Set

Overview

There are two classes of instructions defined in IEEE Standard 1149.1-1990; the standard (public) instructions and device specific (private) instructions. Some public instructions are mandatory for IEEE 1149.1 compliance. Optional public instructions must be implemented in prescribed ways.

Although the TAP controller in this device follows IEEE 1149.1 conventions, it is not IEEE 1149.1-compliant because some of the mandatory instructions are not fully implemented. The TAP on this device may be used to monitor all input and I/O pads, but can not be used to load address, data, or control signals into the device or to preload the I/O buffers. In other words, the device will not perform IEEE 1149.1 EXTEST, INTEST, or the preload portion of the SAMPLE/PRELOAD command.

When the TAP controller is placed in Capture-IR state, the two least significant bits of the instruction register are loaded with 01. When the controller is moved to the Shift-IR state the instruction is serially loaded through the TDI input (while the previous contents are shifted out at TDO). For all instructions, the TAP executes newly loaded instructions only when the controller is moved to Update-IR state. The TAP instruction sets for this device are listed in the following tables.

EXTEST

EXTEST is an IEEE 1149.1 mandatory public instruction. It is to be executed whenever the instruction register is loaded with all 0s. EXTEST is not implemented in this device.

The TAP controller does not recognize an all-0 instruction. When an EXTEST instruction is loaded into the instruction register, the device responds as if a SAMPLE/PRELOAD instruction has been loaded. There is one difference between two instructions. Unlike SAMPLE/PRELOAD instruction, EXTEST places the device outputs in a High-Z state.

IDCODE

The IDCODE instruction causes a vendor-specific, 32-bit code to be loaded into the ID register when the controller is in Capture-DR mode and places the ID register between the TDI

and TDO pins in Shift-DR mode. The IDCODE instruction is the default instruction loaded in the instruction register upon power-up and at any time the TAP controller is placed in the test-logic reset state.

SAMPLE-Z

If the High-Z instruction is loaded in the instruction register, all output pins are forced to a High-Z state and the boundary scan register is connected between TDI and TDO pins when the TAP controller is in a Shift-DR state.

SAMPLE/PRELOAD

SAMPLE/PRELOAD is an IEEE 1149.1 mandatory instruction. The PRELOAD portion of the command is not implemented in this device, so the device TAP controller is not fully IEEE 1149.1-compliant.

When the SAMPLE/PRELOAD instruction is loaded in the instruction register and the TAP controller is in the Capture-DR state, a snap shot of the data in the device's input and I/O buffers is loaded into the boundary scan register. Because the device system clock(s) are independent from the TAP clock (TCK), it is possible for the TAP to attempt to capture the input and I/O ring contents while the buffers are in transition (i.e., in a metastable state). Although allowing the TAP to sample metastable inputs will not harm the device, repeatable results can not be expected. To guarantee that the boundary scan register will capture the correct value of a signal, the device input signals must be stabilized long enough to meet the TAP controller's capture set up plus hold time (t_{CS} plus t_{CH}). The device clock input(s) need not be paused for any other TAP operation except capturing the input and I/O ring contents into the boundary scan register.

Moving the controller to Shift-DR state then places the boundary scan register between the TDI and TDO pins. Because the PRELOAD portion of the command is not implemented in this device, moving the controller to the Update-DR state with the SAMPLE/PRELOAD instruction loaded in the instruction register has the same effect as the Pause-DR command.

BYPASS

When the BYPASS instruction is loaded in the instruction register and the TAP controller is in the Shift-DR state, the bypass register is placed between TDI and TDO. This allows the board level scan path to be shortened to facilitate testing of other devices in the scan path.

Reserved

Do not use these instructions. They are reserved for future use.

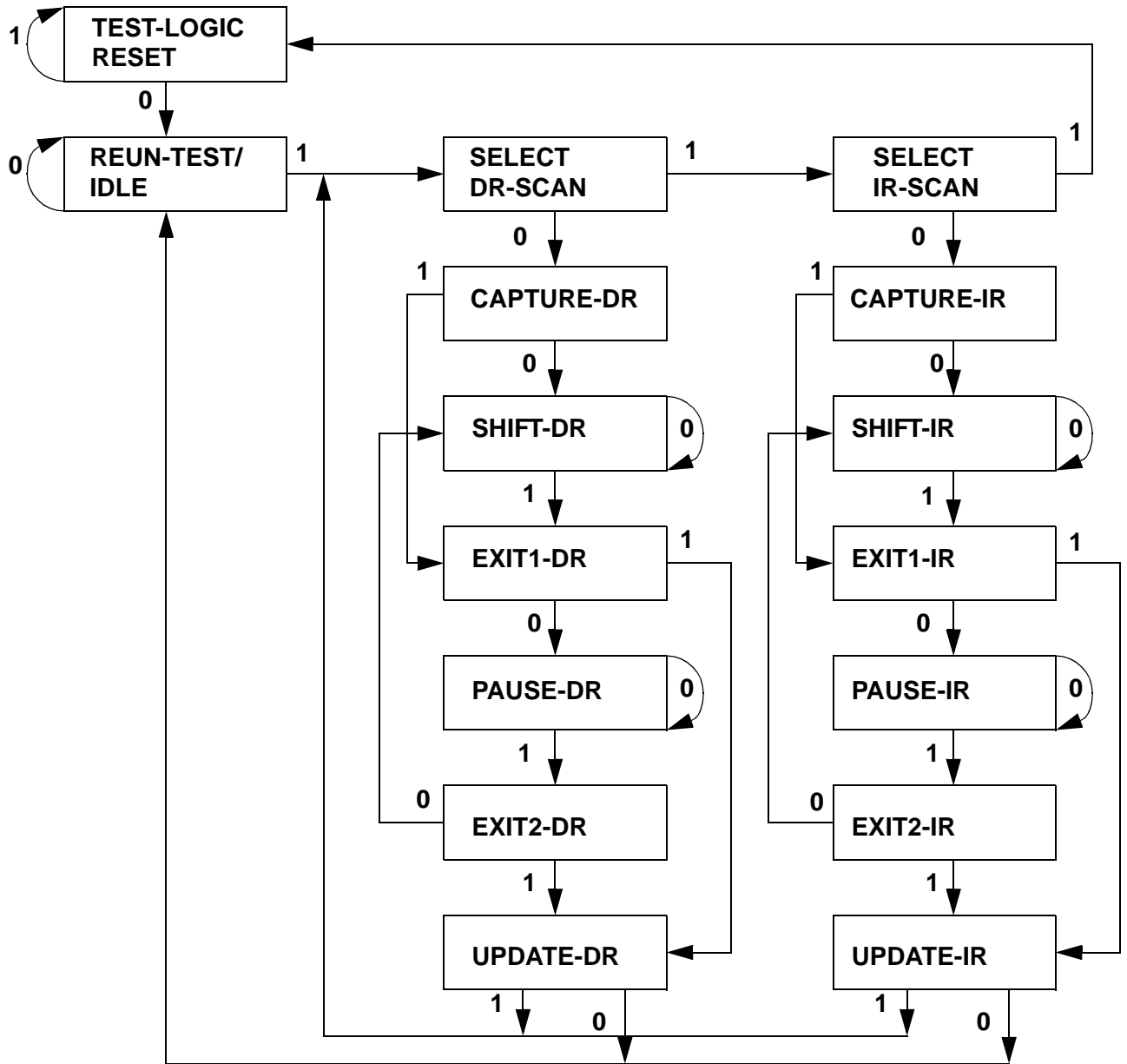
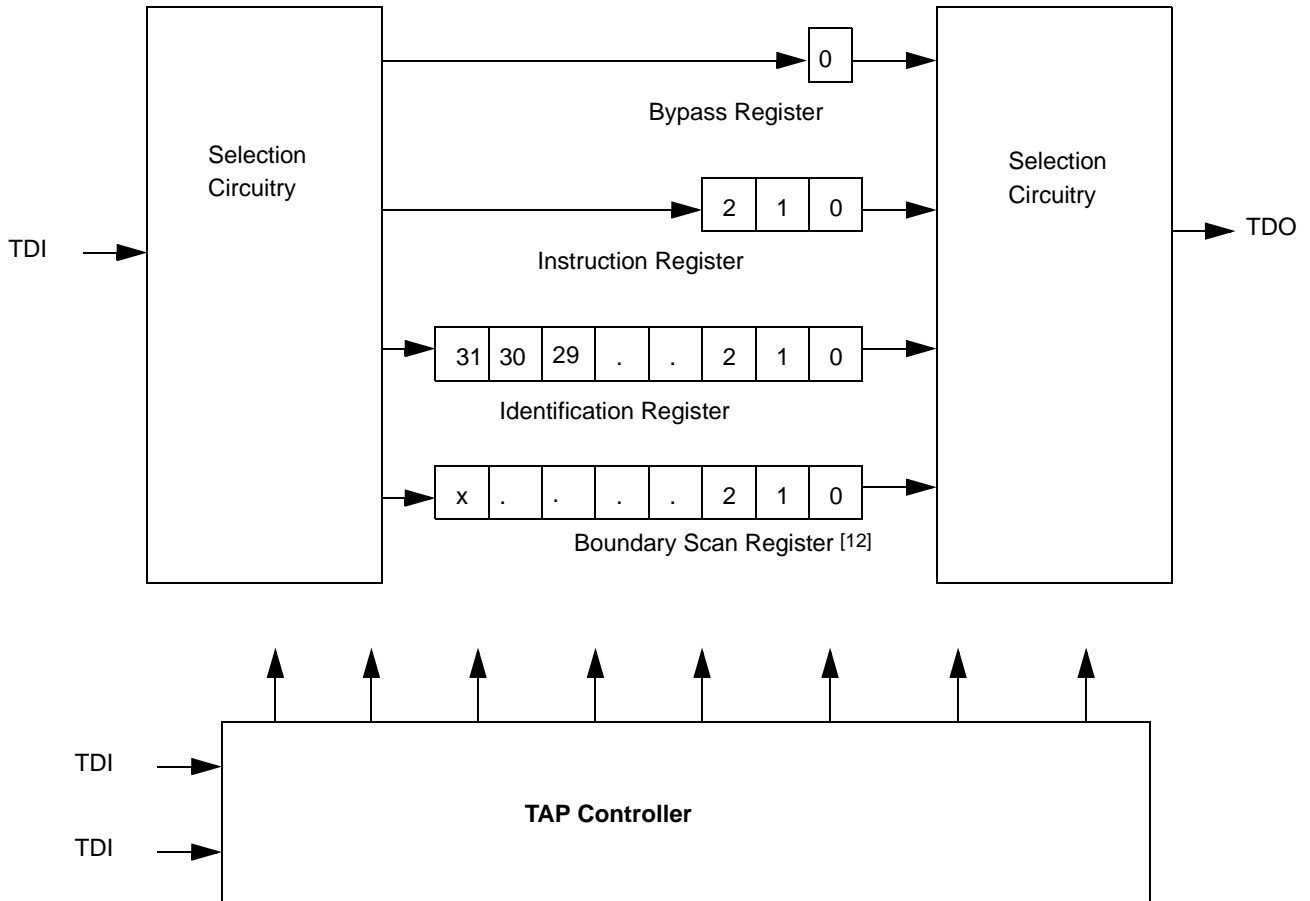

Figure 1. TAP Controller State Diagram^[11]

Note:

11. The "0"/"1" next to each state represents the value at TMS at the rising edge of TCK.

Figure 2. TAP Controller Block Diagram
TAP Electrical Characteristics (20°C < T_j < 110°C; V_{CC} = 3.3V –0.2V and +0.3V unless otherwise noted)

Parameter	Description	Test Conditions	Min.	Max.	Unit
V _{IH}	Input High (Logic 1) Voltage ^[13, 14]		2.0	V _{CC} + 0.3	V
V _{IL}	Input Low (Logic 0) Voltage ^[13, 14]		-0.3	0.8	V
IL _I	Input Leakage Current	0V ≤ V _{IN} ≤ V _{CC}	-5.0	5.0	μA
IL _I	TMS and TDI Input Leakage Current	0V ≤ V _{IN} ≤ V _{CC}	-30	30	μA
IL _O	Output Leakage Current	Output disabled, 0V ≤ V _{IN} ≤ V _{CCQ}	-5.0	5.0	μA
V _{OLC}	LVC MOS Output Low Voltage ^[13, 15]	I _{OLC} = 100 μA		0.2	V
V _{OHC}	LVC MOS Output High Voltage ^[13, 15]	I _{OHC} = 100 μA	V _{CC} - 0.2		V
V _{OLT}	LVTTL Output Low Voltage ^[13]	I _{OLT} = 8.0 mA		0.4	V
V _{OHT}	LVTTL Output High Voltage ^[13]	I _{OHT} = 8.0 mA	2.4		V

Notes:

12. X = 69 for the x36 configuration;
X = 50 for the x18 configuration.
13. All voltage referenced to V_{SS} (GND).
14. Overshoot: V_{IH(AC)} ≤ V_{CC} + 1.5V for t ≤ t_{KHKH}/2; undershoot: V_{IL(AC)} ≤ -0.5V for t ≤ t_{KHKH}/2; power-up: V_{IH} ≤ 3.6V and V_{CC} ≤ 3.135V and V_{CCQ} ≤ 1.4V for t ≤ 200 ms. During normal operation, V_{CCQ} must not exceed V_{CC}. Control input signals (such as R/W, ADV/LD, etc.) may not have pulse widths less than t_{KHKL} (min.).
15. This parameter is sampled.

TAP AC Switching Characteristics Over the Operating Range^[16, 17]

Parameter	Description	Min.	Max.	Unit
Clock				
t_{THTH}	Clock Cycle Time	20		ns
f_{TF}	Clock Frequency		50	MHz
t_{THTL}	Clock HIGH Time	8		ns
t_{TLTH}	Clock LOW Time	8		ns
Output Times				
t_{TLQX}	TCK LOW to TDO Unknown	0		ns
t_{TLQV}	TCK LOW to TDO Valid		10	ns
t_{DVTH}	TDI Valid to TCK HIGH	5		ns
t_{THDX}	TCK HIGH to TDI Invalid	5		ns
Set-up Times				
t_{MVTH}	TMS Set-up	5		ns
t_{TDIS}	TDI Set-up to TCK Clock Rise	5		ns
t_{CS}	Capture Set-up	5		ns
Hold Times				
t_{THMX}	TMS Hold	5		ns
t_{TDIH}	TDI Hold after Clock Rise	5		ns
t_{CH}	Capture Hold	5		ns

Notes:

16. t_{CS} and t_{CH} refer to the set-up and hold time requirements of latching data from the boundary scan register.
17. Test conditions are specified using the load in TAP AC test conditions.

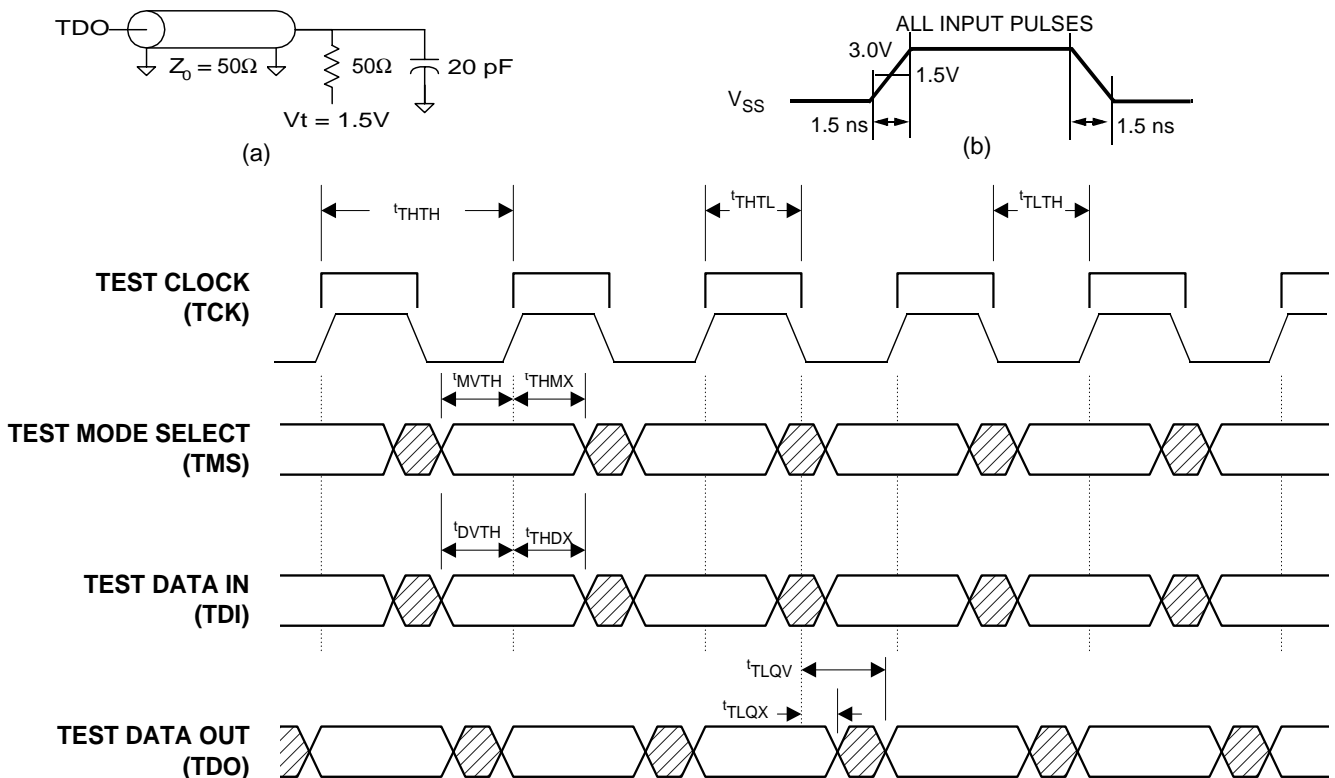
TAP Timing and Test Conditions



Identification Register Definitions

Instruction Field	256K x 36	512K x 18	Description
Revision Number (31:28)	XXXX	XXXX	Reserved for revision number.
Device Depth (27:23)	00110	00111	Defines depth of 256K or 512K words.
Device Width (22:18)	00100	00011	Defines width of x36 or x18 bits.
Reserved (17:12)	XXXXXX	XXXXXX	Reserved for future use.
Cypress JEDEC ID Code (11:1)	00011100100	00011100100	Allows unique identification of DEVICE vendor.
ID Register Presence Indicator (0)	1	1	Indicates the presence of an ID register.

Scan Register Sizes

Register Name	Bit Size (x36)	Bit Size (x18)
Instruction	3	3
Bypass	1	1
ID	32	32
Boundary Scan	70	51

Instruction Codes

Instruction	Code	Description
EXTEST	000	Captures I/O ring contents. Places the boundary scan register between TDI and TDO. Forces all device outputs to High-Z state. This instruction is not IEEE 1149.1-compliant.
IDCODE	001	Preloads ID register with vendor ID code and places it between TDI and TDO. This instruction does not affect device operations.
SAMPLE-Z	010	Captures I/O ring contents. Places the boundary scan register between TDI and TDO. Forces all device outputs to High-Z state.
RESERVED	011	Do not use these instructions; they are reserved for future use.
SAMPLE/PRELOAD	100	Captures I/O ring contents. Places the boundary scan register between TDI and TDO. This instruction does not affect device operations. This instruction does not implement IEEE 1149.1 PRELOAD function and is therefore not 1149.1-compliant.
RESERVED	101	Do not use these instructions; they are reserved for future use.
RESERVED	110	Do not use these instructions; they are reserved for future use.
BYPASS	111	Places the bypass register between TDI and TDO. This instruction does not affect device operations.



Boundary Scan Order (256K x 36)

Bit#	Signal Name	TQFP	Bump ID
1	A	44	2R
2	A	45	3T
3	A	46	4T
4	A	47	5T
5	A	48	6R
6	A	49	3B
7	A	50	5B
8	DQa	51	6P
9	DQa	52	7N
10	DQa	53	6M
11	DQa	56	7L
12	DQa	57	6K
13	DQa	58	7P
14	DQa	59	6N
15	DQa	62	6L
16	DQa	63	7K
17	ZZ	64	7T
18	DQb	68	6H
19	DQb	69	7G
20	DQb	72	6F
21	DQb	73	7E
22	DQb	74	6D
23	DQb	75	7H
24	DQb	78	6G
25	DQb	79	6E
26	DQb	80	7D
27	A	81	6A
28	A	82	5A
29	ADV	83	4G
30	ADSP	84	4A
31	ADSC	85	4B
32	OE	86	4F
33	BWE	87	4M
34	GW	88	4H
35	CLK	89	4K

Boundary Scan Order (256K x 36) (continued)

Bit#	Signal Name	TQFP	Bump ID
36	A	92	6B
37	BWa	93	5L
38	BWb	94	5G
39	BWc	95	3G
40	BWd	96	3L
41	CE ₂	97	2B
42	CE	98	4E
43	A	99	3A
44	A	100	2A
45	DQc	1	2D
46	DQc	2	1E
47	DQc	3	2F
48	DQc	6	1G
49	DQc	7	2H
50	DQc	8	1D
51	DQc	9	2E
52	DQc	12	2G
53	DQc	13	1H
54	NC	14	5R
55	DQd	18	2K
56	DQd	19	1L
57	DQd	22	2M
58	DQd	23	1N
59	DQd	24	2P
60	DQd	25	1K
61	DQd	28	2L
62	DQd	29	2N
63	DQd	30	1P
64	MODE	31	3R
65	A	32	2C
66	A	33	3C
67	A	34	5C
68	A	35	6C
69	A1	36	4N
70	A0	37	4P



Boundary Scan Order (512K x 18)

Bit#	Signal Name	TQFP	Bump ID
1	A	44	2R
2	A	45	2T
3	A	46	3T
4	A	47	5T
5	A	48	6R
6	A	49	3B
7	A	50	5B
8	DQa	58	7P
9	DQa	59	6N
10	DQa	62	6L
11	DQa	63	7K
12	ZZ	64	7T
13	DQa	68	6H
14	DQa	69	7G
15	DQa	72	6F
16	DQa	73	7E
17	DQa	74	6D
18	A	80	6T
19	A	81	6A
20	A	82	5A
21	ADV	83	4G
22	ADSP	84	4A
23	ADSC	85	4B
24	OE	86	4F
25	BWE	87	4M
26	GW	88	4H

Boundary Scan Order (512K x 18) (continued)

Bit#	Signal Name	TQFP	Bump ID
27	CLK	89	4K
28	A	92	6B
29	BWa	93	5L
30	BWb	94	3G
31	CE ₂	97	2B
32	CE	98	4E
33	A	99	3A
34	A	100	2A
35	DQb	8	1D
36	DQb	9	2E
37	DQb	12	2G
38	DQb	13	1H
39	NC	14	5R
40	DQb	18	2K
41	DQb	19	1L
42	DQb	22	2M
43	DQb	23	1N
44	DQb	24	2P
45	MODE	31	3R
46	A	32	2C
47	A	33	3C
48	A	34	5C
49	A	35	6C
50	A1	36	4N
51	A0	37	4P



Maximum Ratings

(Above which the useful life may be impaired. For user guidelines, not tested.)

Voltage on V_{CC} Supply Relative to V_{SS}^[19] -0.5V to +4.6V
 V_{IN} -0.5V to 5.5V
 Storage Temperature (plastic) -55°C to +150°
 Junction Temperature +150°
 Power Dissipation 1.0W

Short Circuit Output Current..... 50 mA
 Static Discharge Voltage > 2001V
 (per MIL-STD-883, Method 3015)
 Latch-up Current..... > 200 mA

Operating Range

Range	Ambient Temperature ^[18]	V _{CC} ^[19]	V _{CCQ}
Commercial	0°C to +70°C	3.3V -5/+10 %	2.5V - 5/ 3.3V + 10%
Industrial	-40°C to +85°C		

Electrical Characteristics Over the Operating Range

Parameter	Description	Test Conditions	Min.	Max.	Unit
V _{IHD}	Input High (Logic 1) Voltage ^[13, 20]	All other inputs	2.0	V _{CC} + 0.3	V
V _{IH}		3.3V I/O	2.0		V
		2.5V I/O	1.7		V
V _{IL}	Input Low (Logic 0) Voltage ^[13, 20]	3.3V I/O	-0.3	0.8	V
		2.5V I/O	-0.3	0.7	V
I _{LI}	Input Leakage Current	0V ≤ V _{IN} ≤ V _{CC}		5	μA
I _{LI}	MODE and ZZ Input Leakage Current ^[21]	0V ≤ V _{IN} ≤ V _{CC}	-	30	μA
I _{LO}	Output Leakage Current	Output(s) disabled, 0V ≤ V _{OUT} ≤ V _{CC}	-	5	μA
V _{OH}	Output High Voltage ^[13]	I _{OH} = -5.0 mA for 3.3V I/O	2.4		V
		I _{OH} = -1.0 mA for 2.5V I/O	2.0		V
V _{OL}	Output Low Voltage ^[13]	I _{OL} = 8.0 mA for 3.3V I/O		0.4	V
		I _{OL} = 1.0 mA for 2.5V I/O		0.4	V
V _{CC} ^[19]	Supply Voltage ^[13]		3.135	3.63	V
V _{CCQ}	I/O Supply Voltage ^[13]	3.3V I/O	3.135	3.63	V
		2.5V I/O	2.375	2.9	V

Parameter	Description	Conditions	Max.					Unit
			Typ.	225 MHz	200 MHz	166 MHz	150 MHz	
I _{CC}	V _{CC} Operating Supply ^[22, 23, 24]	Device selected; all inputs ≤ V _{IL} or ≥ V _{IH} ; V _{CC} = Max.; outputs open, f = f _{MAX} = 1/t _{cyC} .	150	650	620	530	480	mA
I _{SB1}	Automatic CE Power-down Current—TTL Inputs ^[23, 24]	Device deselected; all inputs ≤ V _{IL} or ≥ V _{IH} ; V _{CC} = Max.; f = f _{MAX} = 1/t _{cyC} .	150	350	300	265	225	mA
I _{SB2}	Automatic CE Power-down Current—CMOS Inputs ^[23, 24]	Device deselected; V _{CC} = Max.; all inputs ≤ V _{SS} + 0.2 or ≥ V _{CC} - 0.2; all inputs static; CLK frequency = 0	5	10	10	10	10	mA
I _{SB3}	Automatic CE Power-down Current—CMOS Inputs	Max. V _{DD} Device Deselected, or V _{IN} ≤ 0.3V or V _{IN} ≥ V _{DDQ} - 0.3V f = f _{MAX} = 1/t _{cyC}	90	260	230	200	180	mA
I _{SB4}	Automatic CS Power-down Current—TTL Inputs ^[23, 24]	Device deselected; all inputs ≤ V _{IL} or ≥ V _{IH} ; all inputs static; V _{CC} = Max. CLK frequency = 0	15	30	30	30	30	mA

Capacitance^[15]

Parameter	Description	Test Conditions	Typ.	Max.	Unit
C _I	Input Capacitance	T _A = 25°C, f = 1 MHz,	5	7	pF
C _{I/O}	Input/Output Capacitance (DQ)	V _{CC} = 3.3V	7	8	pF

Notes:

18. T_A is the case temperature.
19. The ground level at the start of "power on" on the V_{CC} pins should be no greater than 200mV.
20. Overshoot: V_{IH} ≤ + 6.0V for t ≤ t_{KC} /2; undershoot: V_{IL} ≤ -2.0V for t ≤ t_{KC} /2.
21. Output loading is specified with C_I = 5 pF as in AC Test Loads.
22. I_{CC} is given with no output current. I_{CC} increases with greater output loading and faster cycle times.
23. "Device Deselected" means the device is in Power-Down mode as defined in the truth table. "Device Selected" means the device is active.
24. Typical values are measured at 3.3V, 25°C, and 20 ns cycle time.

Thermal Resistance^[15]

Parameter	Description	Test Conditions	TQFP Typ.	Unit
Θ_{JA}	Thermal Resistance (Junction to Ambient)	Still Air, soldered on a 4.25 x 1.125 inch, 4-layer PCB	25	°C/W
Θ_{JC}	Thermal Resistance (Junction to Case)		9	°C/W

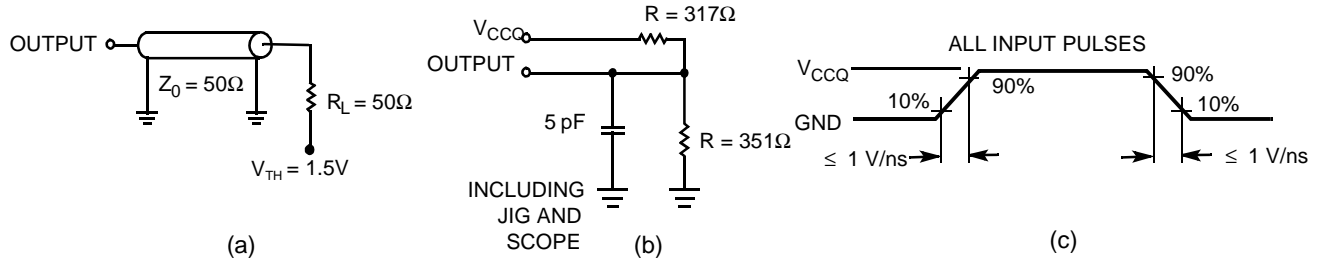
AC Test Loads and Waveforms

Switching Characteristics Over the Operating Range^[24]

Parameter	Description	225 MHz		200 MHz		166 MHz		150 MHz		Unit	
		Min.	Max.	Min.	Max.	Min.	Max.	Min.	Max.		
Clock											
t_{KC}	Clock Cycle Time	4.4		5.0		6.0		6.7		ns	
t_{KH}	Clock HIGH Time	1.8		2.0		2.4		2.6		ns	
t_{KL}	Clock LOW Time	1.8		2.0		2.4		2.6		ns	
Output Times											
t_{KQ}	Clock to Output Valid	$V_{CCQ} = 3.3V$		2.8		3.1		3.5		3.5	ns
		$V_{CCQ} = 2.5V$		2.8		3.1		4.0		4.5	ns
t_{KQX}	Clock to Output Invalid	1.25		1.25		1.25		1.25		ns	
t_{KQLZ}	Clock to Output in Low-Z ^[15, 20, 26]	0		0		0		0		ns	
t_{KQHZ}	Clock to Output in High-Z ^[15, 20, 26]	1.25	3.0	1.25	2.6	1.0	2.8	1.25	4.0	ns	
t_{OEq}	OE to Output Valid ^[27]	$V_{CCQ} = 3.3V$		2.8		3.0		3.5		3.5	ns
		$V_{CCQ} = 2.5V$		2.8		3.0		4.0		4.5	ns
t_{OELZ}	OE to Output in Low-Z ^[15, 20, 26]	0		0		0		0		ns	
t_{OEHz}	OE to Output in High-Z ^[15, 20, 26]		2.8		3.0		3.5		3.5	ns	
Set-up Times											
t_S	Address, Controls, and Data In ^[28]	1.4		1.4		1.5		2.0		ns	
Hold Times											
t_H	Address, Controls, and Data In ^[28]	0.4		0.4		0.5		0.5		ns	

Notes:

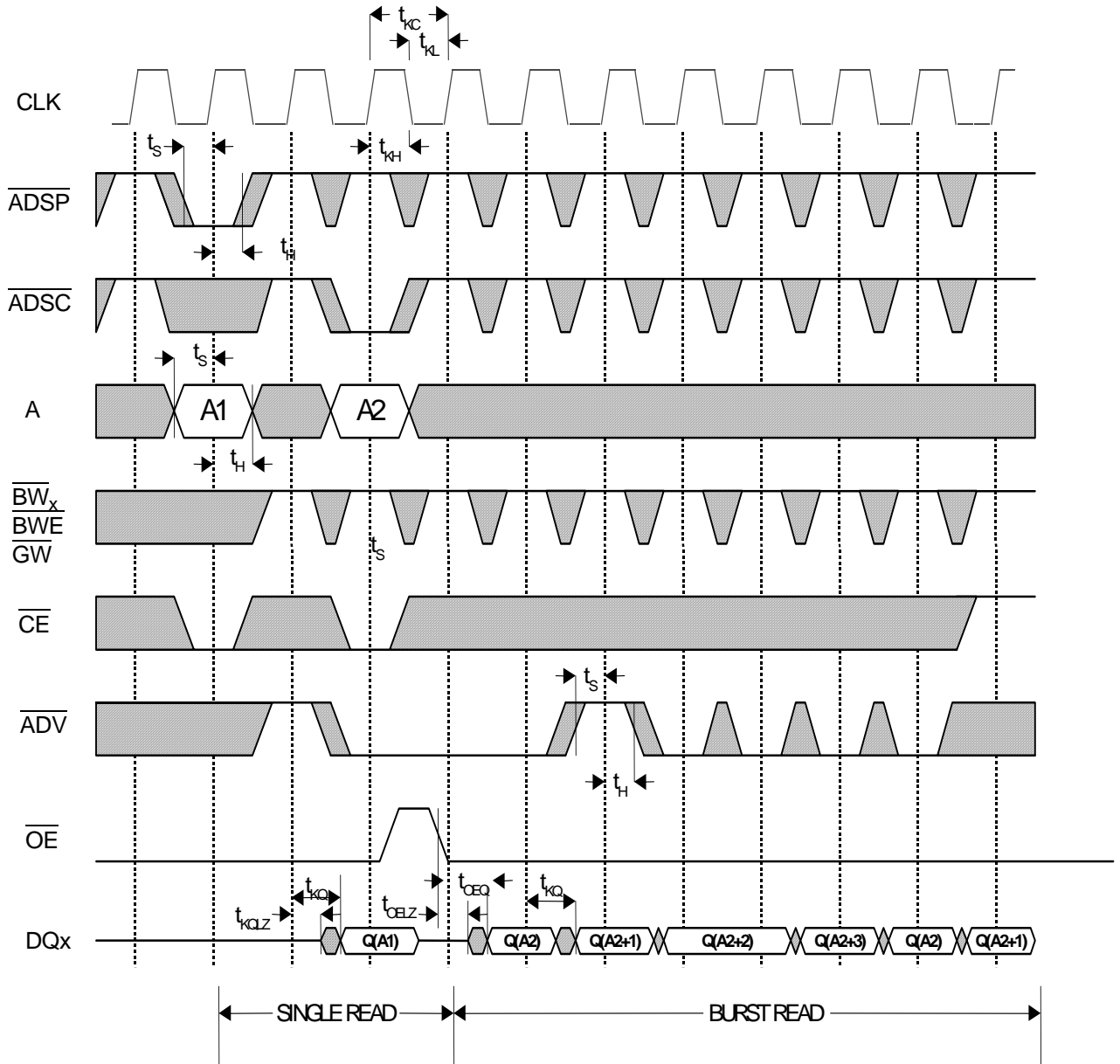
25. Test conditions as specified with the output loading as shown in part (a) of AC Test Loads unless otherwise noted.
26. At any given temperature and voltage condition, t_{KQHZ} is less than t_{KQLZ} and t_{OEHz} is less than t_{OELZ} .
27. OE is a "Don't Care" when a byte Write enable is sampled LOW.
28. This is a synchronous device. All synchronous inputs must meet specified set up and hold time, except for "Don't Care" as defined in the truth table.
29. CE active in this timing diagram means that all chip enables CE, CE₂, and CE₂ are active. CE₂ is only available for TA package version.

Switching Waveforms
Read Timing^[29, 30]

Note:
 30. For the X18 product, there are only \overline{BWA} and \overline{BWB} for byte Write control.

Switching Waveforms (continued)

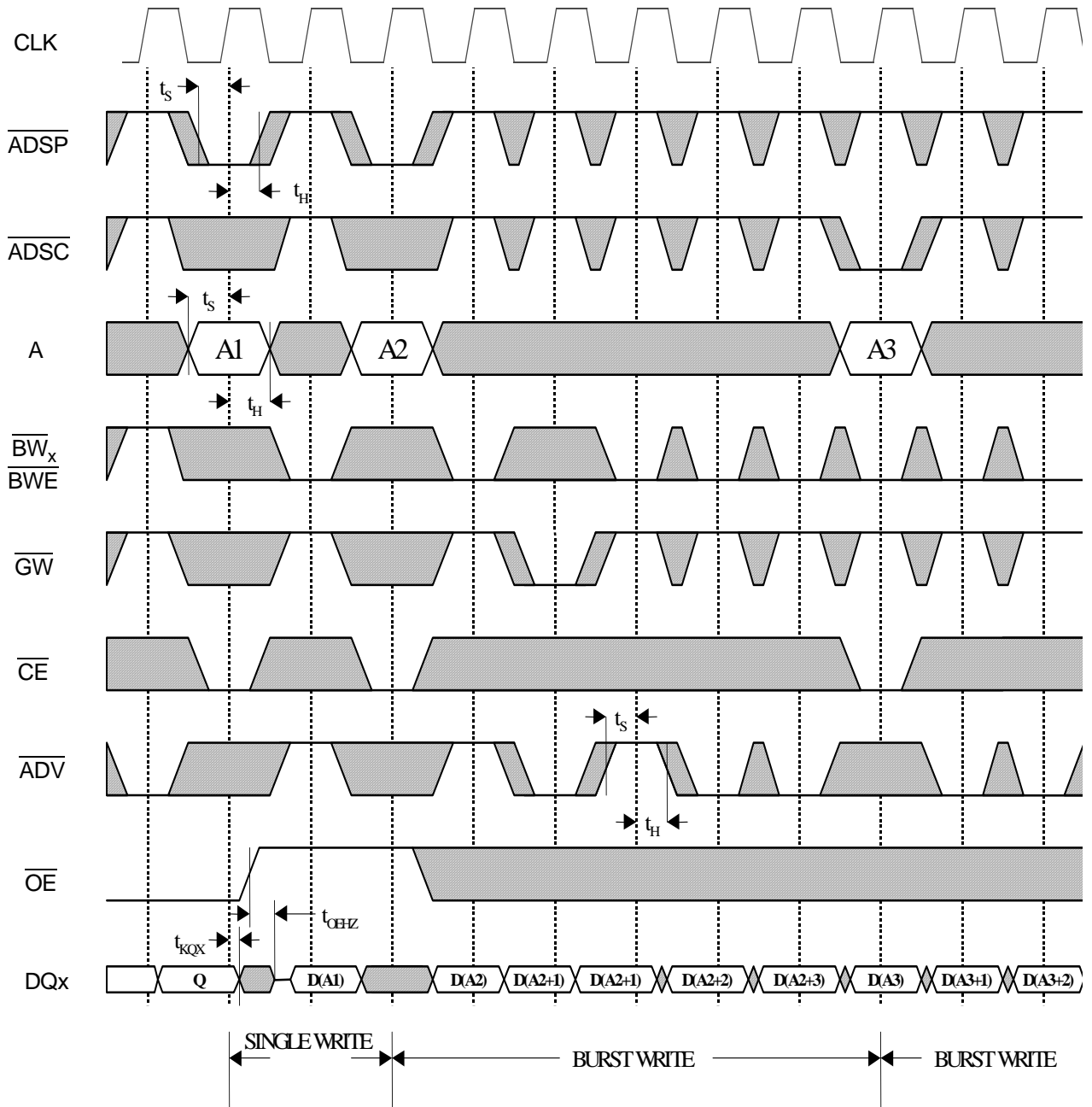
Write Timing^[29, 30]

Switching Waveforms (continued)

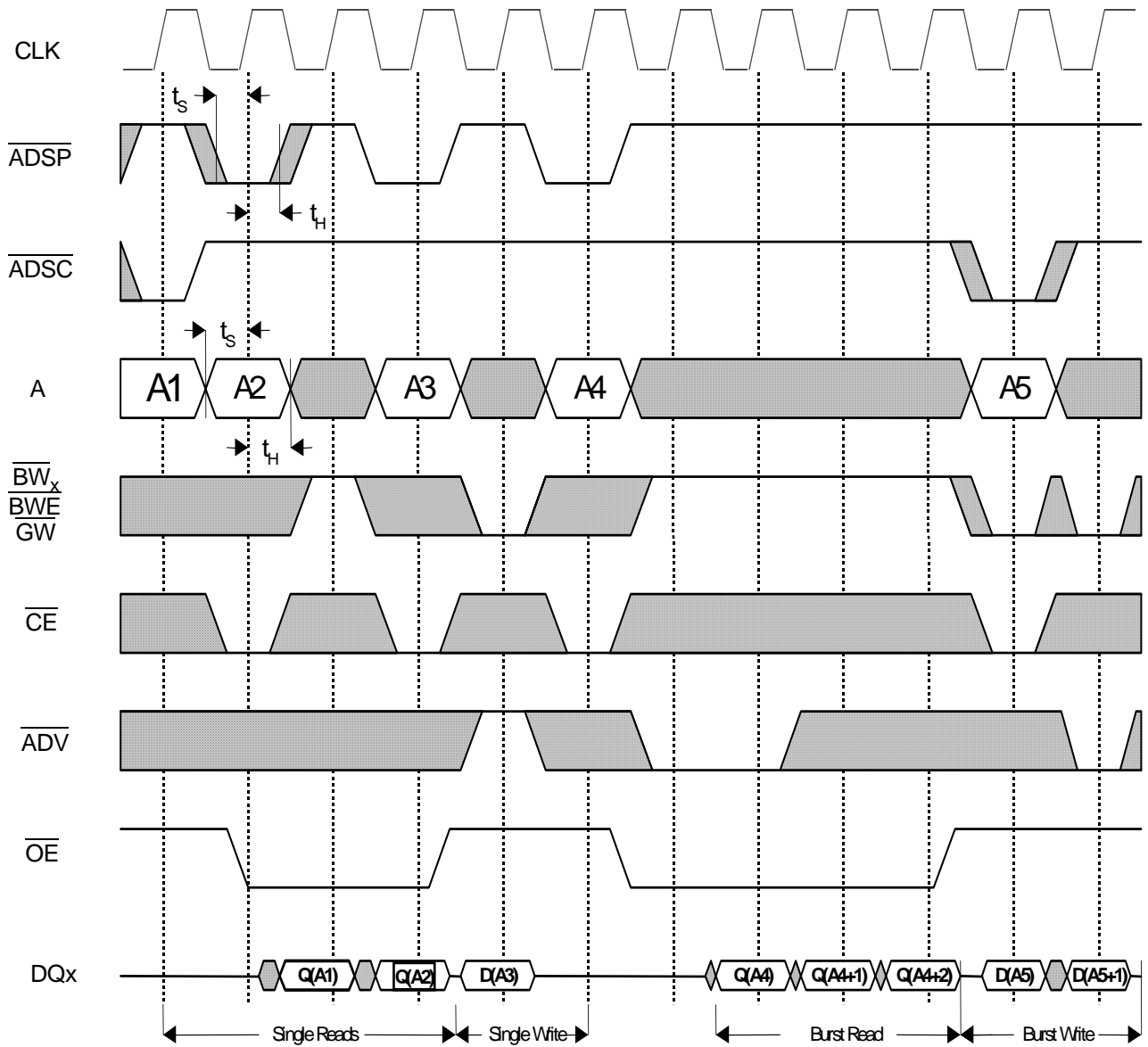
Read/Write Timing^[29, 30]

Switching Waveforms (continued)

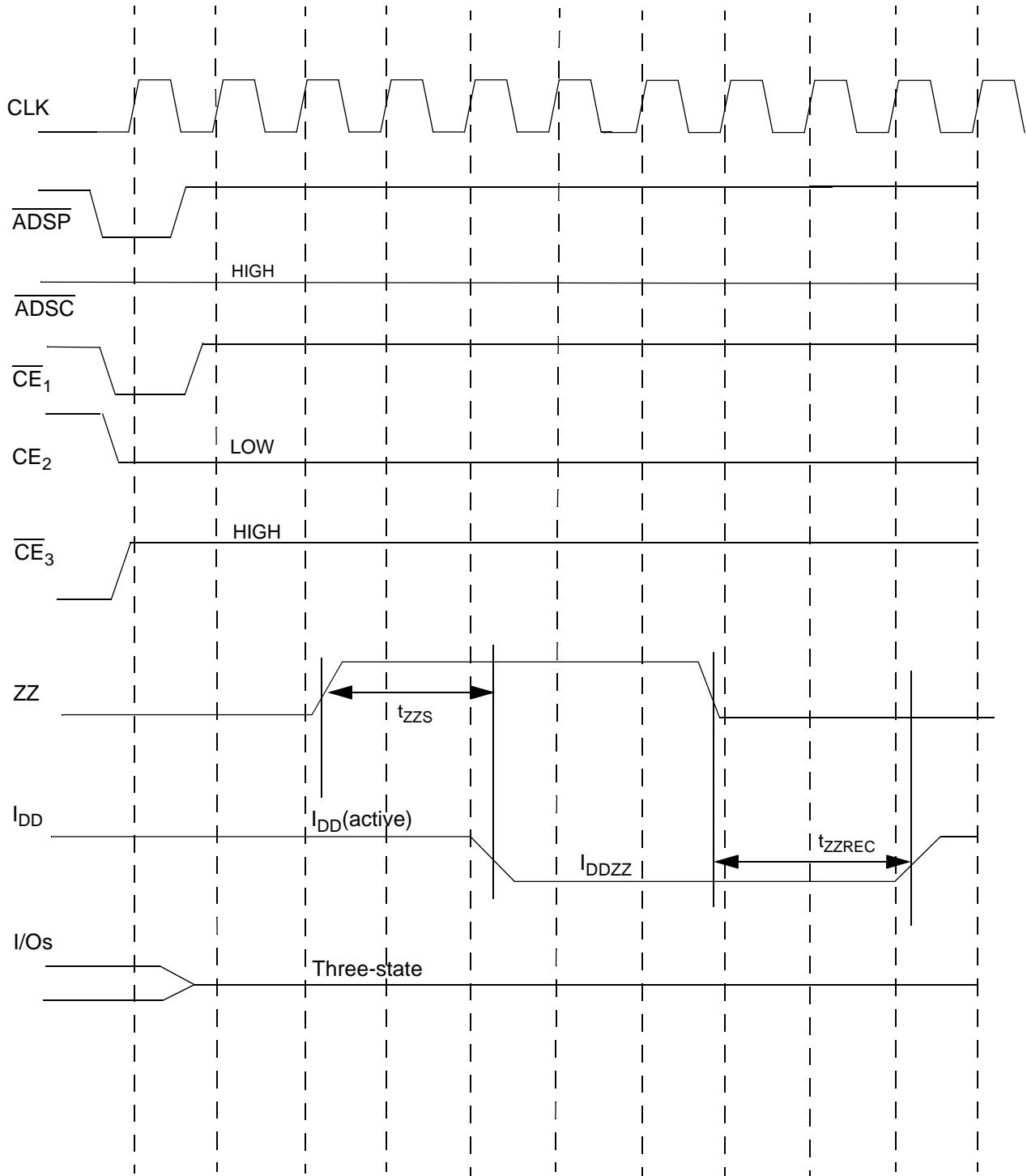
ZZ Mode Timing [31, 32]

Notes:

31. Device must be deselected when entering ZZ mode. See Cycle Descriptions Table for all possible signal conditions to deselect the device.
32. I/Os are in three-state when exiting ZZ sleep mode.



Ordering Information

Speed (MHz)	Ordering Code	Package Name	Package Type	Operating Range
225	CY7C1360A-225AJC	A101	100-Lead 14 x 20 x 1.4 mm Thin Quad Flat Pack	Commercial
	CY7C1360A-225AC	A101	100-Lead 14 x 20 x 1.4 mm Thin Quad Flat Pack	
	CY7C1360A-225BGC	BG119	119-Lead BGA (14 x 22 x 2.4 mm)	
200	CY7C1360A-200AJC	A101	100-Lead 14 x 20 x 1.4 mm Thin Quad Flat Pack	
	CY7C1360A-200AC	A101	100-Lead 14 x 20 x 1.4 mm Thin Quad Flat Pack	
	CY7C1360A-200BGC	BG119	119-Lead BGA (14 x 22 x 2.4 mm)	
166	CY7C1360A-166AJC	A101	100-Lead 14 x 20 x 1.4 mm Thin Quad Flat Pack	
	CY7C1360A-166AC	A101	100-Lead 14 x 20 x 1.4 mm Thin Quad Flat Pack	
	CY7C1360A-166BGC	BG119	119-Lead BGA (14 x 22 x 2.4 mm)	
150	CY7C1360A-150AJC	A101	100-Lead 14 x 20 x 1.4 mm Thin Quad Flat Pack	
	CY7C1360A-150AC	A101	100-Lead 14 x 20 x 1.4 mm Thin Quad Flat Pack	
	CY7C1360A-150BGC	BG119	119-Lead BGA (14 x 22 x 2.4 mm)	
225	CY7C1362A-225AJC	A101	100-Lead 14 x 20 x 1.4 mm Thin Quad Flat Pack	Commercial
	CY7C1362A-225AC	A101	100-Lead 14 x 20 x 1.4 mm Thin Quad Flat Pack	
	CY7C1362A-225BGC	BG119	119-Lead BGA (14 x 22 x 2.4 mm)	
200	CY7C1362A-200AJC	A101	100-Lead 14 x 20 x 1.4 mm Thin Quad Flat Pack	
	CY7C1362A-200AC	A101	100-Lead 14 x 20 x 1.4 mm Thin Quad Flat Pack	
	CY7C1362A-200BGC	BG119	119-Lead BGA (14 x 22 x 2.4 mm)	
166	CY7C1362A-166AJC	A101	100-Lead 14 x 20 x 1.4 mm Thin Quad Flat Pack	
	CY7C1362A-166AC	A101	100-Lead 14 x 20 x 1.4 mm Thin Quad Flat Pack	
	CY7C1362A-166BGC	BG119	119-Lead BGA (14 x 22 x 2.4 mm)	
150	CY7C1362A-150AJC	A101	100-Lead 14 x 20 x 1.4 mm Thin Quad Flat Pack	
	CY7C1362A-150AC	A101	100-Lead 14 x 20 x 1.4 mm Thin Quad Flat Pack	
	CY7C1362A-150BGC	BG119	119-Lead BGA (14 x 22 x 2.4 mm)	
200	CY7C1360A-200AJI	A101	100-Lead 14 x 20 x 1.4 mm Thin Quad Flat Pack	Industrial
	CY7C1360A-200AI	A101	100-Lead 14 x 20 x 1.4 mm Thin Quad Flat Pack	
	CY7C1360A-200BGI	BG119	119-Lead BGA (14 x 22 x 2.4 mm)	
166	CY7C1360A-166AJI	A101	100-Lead 14 x 20 x 1.4 mm Thin Quad Flat Pack	
	CY7C1360A-166AI	A101	100-Lead 14 x 20 x 1.4 mm Thin Quad Flat Pack	
	CY7C1360A-166BGI	BG119	119-Lead BGA (14 x 22 x 2.4 mm)	
150	CY7C1360A-150AJI	A101	100-Lead 14 x 20 x 1.4 mm Thin Quad Flat Pack	
	CY7C1360A-150AI	A101	100-Lead 14 x 20 x 1.4 mm Thin Quad Flat Pack	
	CY7C1360A-150BGI	BG119	119-Lead BGA (14 x 22 x 2.4 mm)	
200	CY7C1362A-200AJI	A101	100-Lead 14 x 20 x 1.4 mm Thin Quad Flat Pack	Industrial
	CY7C1362A-200AI	A101	100-Lead 14 x 20 x 1.4 mm Thin Quad Flat Pack	
	CY7C1362A-200BGI	BG119	119-Lead BGA (14 x 22 x 2.4 mm)	
166	CY7C1362A-166AJI	A101	100-Lead 14 x 20 x 1.4 mm Thin Quad Flat Pack	
	CY7C1362A-166AI	A101	100-Lead 14 x 20 x 1.4 mm Thin Quad Flat Pack	
	CY7C1362A-166BGI	BG119	119-Lead BGA (14 x 22 x 2.4 mm)	
150	CY7C1362A-150AJI	A101	100-Lead 14 x 20 x 1.4 mm Thin Quad Flat Pack	
	CY7C1362A-150AI	A101	100-Lead 14 x 20 x 1.4 mm Thin Quad Flat Pack	
	CY7C1362A-150BGI	BG119	119-Lead BGA (14 x 22 x 2.4 mm)	

Package Diagrams

100-pin Thin Plastic Quad Flatpack (14 x 20 x 1.4 mm) A101

DIMENSIONS ARE IN MILLIMETERS.

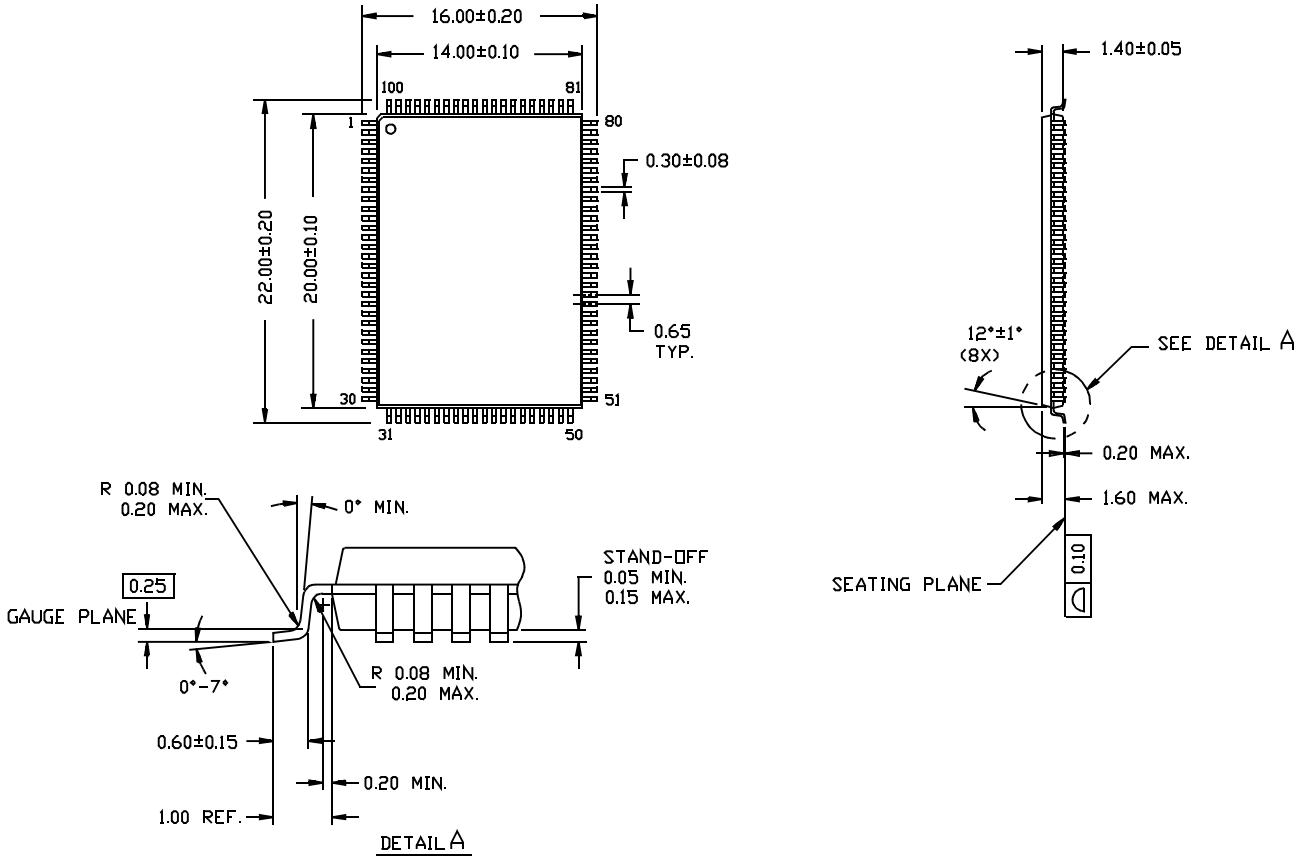

51-85050-A



Document Title: CY7C1360A CY7C1362A 256K x 36/512K x 18 Synchronous Pipelined Burst SRAM				
Document Number: 38-05258				
REV	ECN No.	Issue Date	Orig. of Change	Description of Change
**	113846	05/22/02	GLC	Change from Spec.: 38-00990 to 38-05258
*A	116062	05/28/02	BRI	Removed GVT part numbers from title and body of datasheet Added note 19 (pg. 19) regarding V _{CC} on "Power On"