

## DM74ALS257/DM74ALS258 TRI-STATE® Quad 1-of-2-Line Data Selector/Multiplexer

### General Description

These data selectors/multiplexers contain inverters and drivers to supply full on-chip data selection to the four TRI-STATE outputs that can interface directly with data lines of bus-organized systems. A 4-bit word selected from one of two sources is routed to the four outputs. The ALS257 presents true data whereas the ALS258 presents inverted data to minimize propagation delay time.

This TRI-STATE output feature means that n-bit (paralleled) data selectors with up to 258 sources can be implemented for data buses. It also permits the use of standard TTL registers for data retention throughout the system.

### Features

- Switching specifications at 50 pF
- Switching specifications guaranteed over full temperature and  $V_{CC}$  range
- Advanced oxide-isolated, ion-implanted Schottky TTL process
- Functionally and pin for pin compatible with Schottky and low power Schottky TTL counterpart
- Improved AC performance over Schottky and low power Schottky counterparts
- TRI-STATE buffer-type outputs drive bus lines directly
- Expand any data input point
- Multiplex dual data buses
- General four functions of two variables (one variable is common)
- Source programmable counters

### Connection Diagram

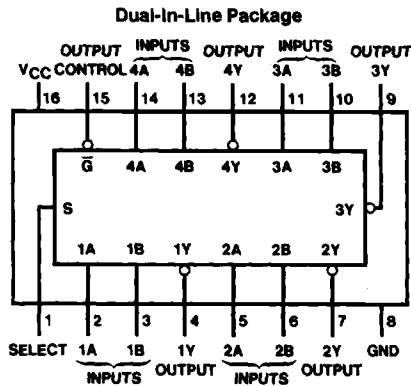

TL/F/6227-1

Order Number DM74ALS257M,  
DM74ALS258M, DM74ALS257N, DM74ALS258N  
See NS Package Number M16A or N16A

### Function Table

Output Control	Inputs		Output Y		
	Select	A	B	ALS257	ALS258
H	X	X	X	Z	Z
L	L	L	X	L	H
L	L	H	X	H	L
L	H	X	L	L	H
L	H	X	H	H	L

H = High Level, L = Low Level, X = Don't Care  
Z = High Impedance (off)

## Absolute Maximum Ratings

Supply Voltage	7V
Input Voltage	7V
Voltage Applied to Disabled Output	5.5V
Operating Free Air Temperature Range DM74ALS	0°C to +70°C
Storage Temperature Range	-65°C to +150°C
Typical $\theta_{JA}$	
N Package	73.0°C/W
M Package	102.0°C/W

Note: The "Absolute Maximum Ratings" are those values beyond which the safety of the device cannot be guaranteed. The device should not be operated at these limits. The parametric values defined in the "Electrical Characteristics" table are not guaranteed at the absolute maximum ratings. The "Recommended Operating Conditions" table will define the conditions for actual device operation.

## Recommended Operating Conditions

Symbol	Parameter	DM74ALS257, 258			Units
		Min	Nom	Max	
V <sub>CC</sub>	Supply Voltage	4.5	5	5.5	V
V <sub>IH</sub>	High Level Input Voltage	2			V
V <sub>IL</sub>	Low Level Input Voltage			0.8	V
I <sub>OH</sub>	High Level Output Current			-2.6	mA
I <sub>OL</sub>	Low Level Output Current			24	mA
T <sub>A</sub>	Free Air Operating Temperature	0		70	°C

## Electrical Characteristics

over recommended operating free air temperature range. All typical values are measured at V<sub>CC</sub> = 5V, T<sub>A</sub> = 25°C.

Symbol	Parameter	Conditions	Min	Typ	Max	Units	
V <sub>IK</sub>	Input Clamp Voltage	V <sub>CC</sub> = 4.5V, I <sub>I</sub> = -18 mA			-1.5	V	
V <sub>OH</sub>	High Level Output Voltage	V <sub>CC</sub> = 4.5V, I <sub>OH</sub> = -2.6 mA	2.4	3.3		V	
		I <sub>OH</sub> = -0.4 mA	V <sub>CC</sub> - 2			V	
V <sub>OL</sub>	Low Level Output Voltage	V <sub>CC</sub> = 4.5V, I <sub>OL</sub> = 12 mA		0.25	0.4	V	
		I <sub>OL</sub> = 24 mA		0.35	0.5	V	
I <sub>I</sub>	Input Current at Max Input Voltage	V <sub>CC</sub> = 5.5V, V <sub>IH</sub> = 7V			0.1	mA	
I <sub>IH</sub>	High Level Input Current	V <sub>CC</sub> = 5.5V, V <sub>IH</sub> = 2.7V			20	μA	
I <sub>IL</sub>	Low Level Input Current	V <sub>CC</sub> = 5.5V, V <sub>IL</sub> = 0.4V			-0.1	mA	
I <sub>O</sub>	Output Drive Current	V <sub>CC</sub> = 5.5V, V <sub>O</sub> = 2.25V	-30		-112	mA	
I <sub>OZH</sub>	Off-State Output Current, High Level Voltage Applied	V <sub>CC</sub> = 5.5V, V <sub>O</sub> = 2.7V			20	μA	
I <sub>OZL</sub>	Off-State Output Current, Low Level Voltage Applied	V <sub>CC</sub> = 5.5V, V <sub>O</sub> = 0.4V			-20	μA	
I <sub>CCH</sub>	Supply Current	ALS257	V <sub>CC</sub> = 5.5V Outputs Open	Outputs High	3	6	mA
		ALS258			2.5	4	mA
I <sub>CCL</sub>	Supply Current	ALS257	Outputs Low	8	12	mA	
		ALS258		7	11	mA	
I <sub>CCZ</sub>	Supply Current	ALS257	Outputs Disabled	9	14	mA	
		ALS258		8	13	mA	

**'ALS257 Switching Characteristics** over recommended operating free air temperature range (Note 1)

Symbol	Parameter	Conditions	From	To	DM74ALS257		Units
					Min	Max	
t <sub>PLH</sub>	Propagation Delay Time Low to High Level Output	V <sub>CC</sub> = 4.5V to 5.5V C <sub>L</sub> = 50 pF R <sub>L</sub> = 500Ω	Data	Any Y	2	10	ns
t <sub>PHL</sub>	Propagation Delay Time High to Low Level Output		Data	Any Y	2	12	ns
t <sub>PLH</sub>	Propagation Delay Time Low to High Level Output		Select	Any Y	4	18	ns
t <sub>PHL</sub>	Propagation Delay Time High to Low Level Output		Select	Any Y	5	22	ns
t <sub>ZH</sub>	Output Enable Time to High Level		Output Control	Any Y	4	16	ns
t <sub>ZL</sub>	Output Enable Time to Low Level		Output Control	Any Y	5	18	ns
t <sub>HZ</sub>	Output Disable Time from High Level		Output Control	Any Y	2	10	ns
t <sub>LZ</sub>	Output Disable Time from Low Level		Output Control	Any Y	3	15	ns

**'ALS258 Switching Characteristics** over recommended operating free air temperature range (Note 1)

Symbol	Parameter	Conditions	From	To	DM74ALS258		Units
					Min	Max	
t <sub>PLH</sub>	Propagation Delay Time Low to High Level Output	V <sub>CC</sub> = 4.5V to 5.5V C <sub>L</sub> = 50 pF R <sub>L</sub> = 500Ω	Data	Any Y	2	8	ns
t <sub>PHL</sub>	Propagation Delay Time High to Low Level Output		Data	Any Y	2	7	ns
t <sub>PLH</sub>	Propagation Delay Time Low to High Level Output		Select	Any Y	3	20	ns
t <sub>PHL</sub>	Propagation Delay Time High to Low Level Output		Select	Any Y	5	25	ns
t <sub>ZH</sub>	Output Enable Time to High Level		Output Control	Any Y	5	18	ns
t <sub>ZL</sub>	Output Enable Time to Low Level		Output Control	Any Y	5	18	ns
t <sub>HZ</sub>	Output Disable Time from High Level		Output Control	Any Y	2	10	ns
t <sub>LZ</sub>	Output Disable Time from Low Level		Output Control	Any Y	3	18	ns

Note 1: See Section 5 for test waveforms and output load.

Logic Diagrams

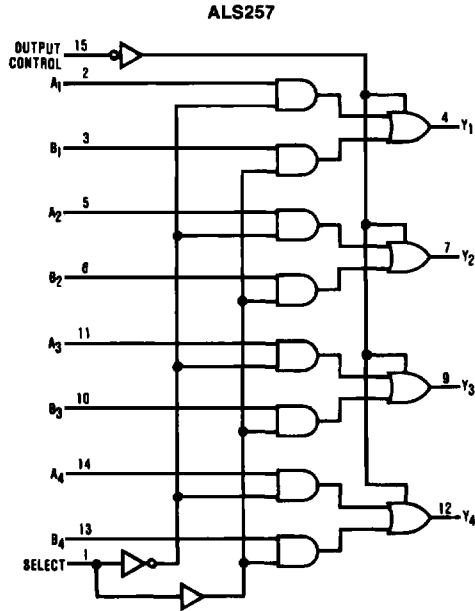

TL/F/6227-2

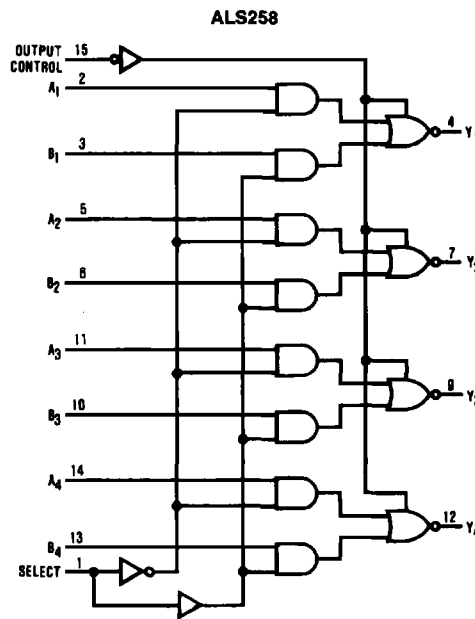

TL/F/6227-3