

## DM74ALS804A Hex 2-Input NAND Driver

### General Description

This device contains six independent 2-input drivers, each of which performs the logic NAND function.

### Features

- Switching specifications at 50 pF
- Switching specifications guaranteed over full temperature and  $V_{CC}$  range
- Advanced oxide-isolated, ion-implanted Schottky TTL process
- Functionally and pin for pin compatible with Schottky and low power Schottky TTL counterpart
- Improved AC performance over Schottky and low power Schottky counterparts

### Connection Diagram

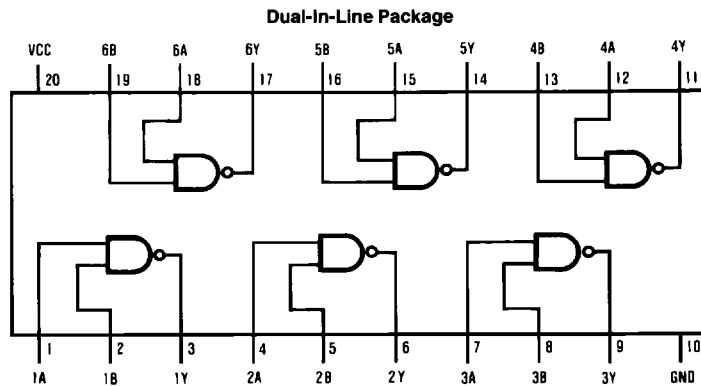

Order Number DM74ALS804AWM or DM74ALS804AN  
See NS Package Number M20B or N20A

TL/F/6239-1

### Function Table

$$Y = \overline{AB}$$

Inputs		Output
A	B	Y
L	L	H
L	H	H
H	L	H
H	H	L

H = High Logic Level

L = Low Logic Level

## Absolute Maximum Ratings

Supply Voltage	7V
Input Voltage	7V
Operating Free Air Temperature Range DM74ALS	0°C to +70°C
Storage Temperature Range	-65°C to +150°C
Typical $\theta_{JA}$	
N Package	58.0°C/W
M Package	78.0°C/W

Note: The "Absolute Maximum Ratings" are those values beyond which the safety of the device cannot be guaranteed. The device should not be operated at these limits. The parametric values defined in the "Electrical Characteristics" table are not guaranteed at the absolute maximum ratings. The "Recommended Operating Conditions" table will define the conditions for actual device operation.

## Recommended Operating Conditions

Symbol	Parameter	DM74ALS804A			Units
		Min	Nom	Max	
$V_{CC}$	Supply Voltage	4.5	5	5.5	V
$V_{IH}$	High Level Input Voltage	2			V
$V_{IL}$	Low Level Input Voltage			0.8	V
$I_{OH}$	High Level Output Current			-15	mA
$I_{OL}$	Low Level Output Current			24	mA
$T_A$	Free Air Operating Temperature	0		70	°C

\*Applies for the DM74ALS804-1 option only.

## Electrical Characteristics

over recommended operating free air temperature range. All typical values are measured at  $V_{CC} = 5V$ ,  $T_A = 25^\circ C$ .

Symbol	Parameter	Conditions	Min	Typ	Max	Units
$V_{IK}$	Input Clamp Voltage	$V_{CC} = 4.5V$ , $I_I = -18 mA$			-1.2	V
$V_{OH}$	High Level Output Voltage	$I_{OH} = -0.4 mA$ , $V_{CC} = 4.5V$ to $5.5V$	$V_{CC} - 2$			V
		$I_{OH} = -3 mA$ , $V_{CC} = 4.5V$	2.4			V
		$I_{OH} = \text{Max}$ , $V_{CC} = 4.5V$	2			V
$V_{OL}$	Low Level Output Voltage	$V_{CC} = 4.5V$ 74ALS $I_{OL} = 24 mA$		0.35	0.5	V
$I_I$	Input Current at Max Input Voltage	$V_{CC} = 5.5V$ , $V_{IH} = 7V$			0.1	mA
$I_{IH}$	High Level Input Current	$V_{CC} = 5.5V$ , $V_{IH} = 2.7V$			20	$\mu A$
$I_{IL}$	Low Level Input Current	$V_{CC} = 5.5V$ , $V_{IL} = 0.4V$			-0.1	mA
$I_O$	Output Drive Current	$V_{CC} = 5.5V$ , $V_O = 2.25V$	-30		-112	mA
$I_{CC}$	Supply Current	$V_{CC} = 5.5V$ $V_I = 0V$ , Outputs High		0.9	2.5	mA
		$V_I = 4.5V$ , Outputs Low		7	12	mA

## Switching Characteristics over recommended operating free air temperature range (Note 1)

Symbol	Parameter	Conditions	DM74ALS804A		Units
			Min	Max	
$t_{PLH}$	Propagation Delay Time Low to High Level Output	$V_{CC} = 4.5V$ to $5.5V$ $R_L = 500\Omega$ $C_L = 50 pF$	2	7	ns
$t_{PHL}$	Propagation Delay Time High to Low Level Output		2	8	ns

Note 1: See Section 5 for test waveforms and output load.