

## DM74ALS86

### Quad 2-Input Exclusive-OR Gate

#### General Description

This device contains four independent gates, each of which performs the logic exclusive-OR function.

#### Features

- Switching specifications at 50 pF
- Switching specifications guaranteed over full temperature and  $V_{CC}$  range
- Advanced oxide-isolated, ion-implanted Schottky TTL process
- Functionally and pin for pin compatible with Schottky and low power Schottky TTL counterpart
- Improved AC performance over Schottky and low power Schottky counterparts

#### Connection Diagram

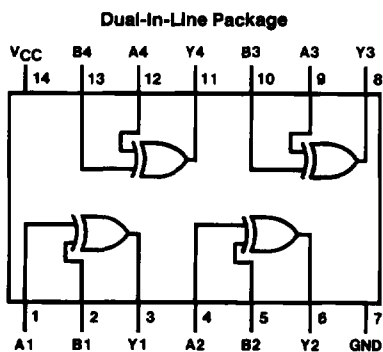

TL/F/6195-1

Order Number **DM74ALS86M** or **DM74ALS86N**  
 See NS Package Number **M14A** or **N14A**

#### Function Table

$$Y = A \oplus B = \bar{A}B + A\bar{B}$$

| Inputs |   | Output |
|--------|---|--------|
| A      | B | Y      |
| L      | L | L      |
| L      | H | H      |
| H      | L | H      |
| H      | H | L      |

H = High Logic Level  
 L = Low Logic Level

## Absolute Maximum Ratings

|   |                 |
|---|-----------------|
| Supply Voltage                                  | 7V              |
| Input Voltage                                   | 7V              |
| Operating Free Air Temperature Range<br>DM74ALS | 0°C to +70°C    |
| Storage Temperature Range                       | -65°C to +150°C |
| Typical $\theta_{JA}$                           |                 |
| N Package                                       | 87.0°C/W        |
| M Package                                       | 117.2°C/W       |

Note: The "Absolute Maximum Ratings" are those values beyond which the safety of the device cannot be guaranteed. The device should not be operated at these limits. The parametric values defined in the "Electrical Characteristics" table are not guaranteed at the absolute maximum ratings. The "Recommended Operating Conditions" table will define the conditions for actual device operation.

## Recommended Operating Conditions

| Symbol   | Parameter                      | DM74ALS86 |     |      | Units |
|----------|--------------------------------|-----------|-----|------|-------|
|          |                                | Min       | Nom | Max  |       |
| $V_{CC}$ | Supply Voltage                 | 4.5       | 5   | 5.5  | V     |
| $V_{IH}$ | High Level Input Voltage       | 2         |     |      | V     |
| $V_{IL}$ | Low Level Input Voltage        |           |     | 0.8  | V     |
| $I_{OH}$ | High Level Output Current      |           |     | -0.4 | mA    |
| $I_{OL}$ | Low Level Output Current       |           |     | 8    | mA    |
| $T_A$    | Free Air Operating Temperature | 0         |     | 70   | °C    |

## Electrical Characteristics

over recommended operating free air temperature range. All typical values are measured at  $V_{CC} = 5V$ ,  $T_A = 25^\circ C$ .

| Symbol    | Parameter                          | Conditions   | Min          | Typ  | Max  | Units   |
|-----------|------------------------------------|--|--------------|------|------|---------|
| $V_{IK}$  | Input Clamp Voltage                | $V_{CC} = 4.5V$ , $I_I = -18 mA$                             |              |      | -1.5 | V       |
| $V_{OH}$  | High Level Output Voltage          | $I_{OH} = -0.4 mA$<br>$V_{CC} = 4.5V$ to $5.5V$              | $V_{CC} - 2$ |      |      | V       |
| $V_{OL}$  | Low Level Output Voltage           | $V_{CC} = 4.5V$<br>$I_{OL} = 4 mA$                           |              | 0.25 | 0.4  | V       |
|           |                                    |  |              | 0.35 | 0.5  | V       |
| $I_I$     | Input Current @ Max. Input Voltage | $V_{CC} = 5.5V$ , $V_{IH} = 7V$                              |              |      | 0.1  | mA      |
| $I_{IH}$  | High Level Input Current           | $V_{CC} = 5.5V$ , $V_{IH} = 2.7V$                            |              |      | 20   | $\mu A$ |
| $I_{IL}$  | Low Level Input Current            | $V_{CC} = 5.5V$ , $V_{IL} = 0.4V$                            |              |      | -0.1 | mA      |
| $I_O$     | Output Drive Current               | $V_{CC} = 5.5V$ , $V_O = 2.25V$                              | -30          |      | -112 | mA      |
| $I_{CCL}$ | Supply Current with Outputs Low    | $V_{CC} = \text{Max}$ , All Inputs at 4.5V                   |              | 3.9  | 5.9  | mA      |
| $I_{CCH}$ | Supply Current with Outputs High   | $V_{CC} = \text{Max}$ , A Inputs at 0.0V<br>B Inputs at 4.5V |              | 3.8  | 4.5  | mA      |

## Switching Characteristics

over recommended operating free air temperature range (Note 1).

| Symbol    | Parameter                                       | Conditions                                 | DM74ALS86 |     | Units |
|-----------|---|--|-----------|-----|-------|
|           |   |  | Min       | Max |       |
| $t_{PLH}$ | Propagation Delay Time Low to High Level Output | (Note 2)<br>A or B to Y<br>Other Input Low | 3         | 17  | ns    |
| $t_{PHL}$ | Propagation Delay Time High to Low Level Output |  | 2         | 12  | ns    |
| $t_{PLH}$ | Propagation Delay Time Low to High Level Output | A or B to Y<br>Other Input High            | 2         | 17  | ns    |
| $t_{PHL}$ | Propagation Delay Time High to Low Level Output |  | 2         | 10  | ns    |

Note 1: See Section 5 for test waveforms and output load.

Note 2:  $V_{CC} = 4.5V$  to  $5.5V$ ,  $R_L = 500\Omega$ ,  $C_L = 50 pF$ .