

DM74AS1805 Hex 2-Input NOR Driver

General Description

These devices contain six independent 2-Input drivers each of which performs the logic NOR function. The 'AS1805 is equivalent to the 'AS805B but the supply voltage and ground pins are centered in the package. This positioning of the supply voltage and ground pins reduce the lead inductance of these pins. This reduction of lead inductance will minimize noise generated onto either the supply voltage or ground bus which is significant in high current switching applications.

Features

- Switching specifications at 50 pF
- Switching specifications guaranteed over full temperature and V_{CC} range
- Advanced oxide-isolated, ion-implanted Schottky TTL process
- Centered V_{CC} and GND configuration provides minimum lead inductance for high current switching applications
- High capacitive drive capability

Connection Diagram

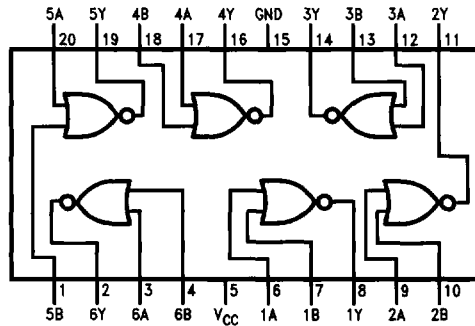

TL/F/8618-1

Order Number **DM74AS1805WM** or **DM74AS1805N**
See NS Package Number **M20B** or **N20A**

Function Table

$$Y = \overline{A + B}$$

INPUTS		OUTPUT
A	B	Y
L	L	H
L	H	L
H	L	L
H	H	L

Absolute Maximum Ratings

Supply Voltage	7V
Input Voltage	7V
Operating Free Air Temperature	0°C to 70°C
Storage Temperature Range	-65°C to +150°C
Typical θ_{JA}	
N Package	58.3°C/W
M Package	154.0°C/W

Note: The "Absolute Maximum Ratings" are those values beyond which the safety of the device cannot be guaranteed. The device should not be operated at these limits. The parametric values defined in the "Electrical Characteristics" table are not guaranteed at the absolute maximum ratings. The "Recommended Operating Conditions" table will define the conditions for actual device operation.

Recommended Operating Conditions

Symbol	Parameter	Min	Nom	Max	Units
V_{CC}	Supply Voltage	4.5	5	5.5	V
V_{IH}	High Level Input Voltage	2			V
V_{IL}	Low Level Input Voltage			0.8	V
I_{OH}	High Level Output Current			-48	mA
I_{OL}	Low Level Output Current			48	mA
T_A	Operating Free Air Temperature Range	0		70	°C

Electrical Characteristics over recommended operating free air temperature range

Symbol	Parameter	Conditions	Min	Typ	Max	Units
V_{IK}	Input Clamp Voltage	$V_{CC} = 4.5V, I_I = -18\text{ mA}$			-1.2	V
V_{OH}	High Level Output Voltage	$I_{OH} = -2\text{ mA}, V_{CC} = 4.5V\text{ to }5.5V$	$V_{CC} - 2$			V
		$I_{OH} = -3\text{ mA}, V_{CC} = 4.5V$	2.4	3.2		
		$I_{OH} = \text{Max}, V_{CC} = 4.5V$	2			
V_{OL}	Low Level Output Voltage	$V_{CC} = 4.5V, I_{OL} = \text{Max}, V_{IH} = 2V$			0.5	V
I_I	Input Current at Maximum Input Voltage	$V_{CC} = 5.5V, V_I = 7V$			100	μA
I_{IH}	High Level Input Current	$V_{CC} = 5.5V, V_I = 2.7V$			20	μA
I_{IL}	Low Level Input Current	$V_{CC} = 5.5V, V_I = 0.4V$			-500	μA
I_O	Output Drive Current	$V_{CC} = 5.5V, V_O = 2.25V$	-50	-135	-200	mA
I_{CCH}	Supply Current with Outputs High	$V_{CC} = 5.5V$		6.5	10	mA
I_{CCL}	Supply Current with Outputs Low	$V_{CC} = 5.5V$		20	32	mA

Switching Characteristics over recommended operating free air temperature range (Note 1)

Symbol	Parameter	Conditions (Note 1)	Min	Max	Units
T_{PLH}	Propagation Delay Time Low to High Level Output	$V_{CC} = 4.5V\text{ to }5.5V$ $R_L = 500\Omega$ $C_L = 50\text{ pF}$	1	4.3	ns
T_{PHL}	Propagation Delay Time High to Low Level Output		1	4.3	ns

Note 1: See Section 5 for test waveforms and output load.