

DS8692, DS8693, DS8694 Printing Calculator Interface Set

General Description

Two DS8692 IC's and one each of the DS8693 and DS8694 provide the complete interface necessary between the MM5787 calculator chip and the Seiko Model 310 printing head. The DS8692 is an array of eight common emitter output transistors each capable of sinking 350 mA, with open collector saturating outputs. The DS8693 contains the interface logic for the color solenoid driver, motor driver, and 7-column character select solenoid drivers. The DS8694 contains the interface logic for 8-column solenoid drivers plus the clock oscillator and timing signal buffer. The color and character select solenoid latch outputs of both are

constant current outputs supplying the base current for the DS8692 arrays. These outputs also feature active pull-down. The motor drive latch output is an open collector capable of sinking 20 mA.

Features

- Provides complete interface package for printing calculators with minimum number of packages and minimum number of external components
- 350 mA sink capability

Connection Diagrams

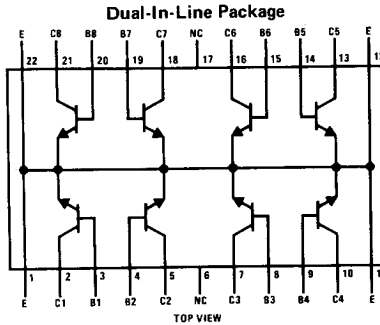

Order Number **DS8692N**
See NS Package N22A

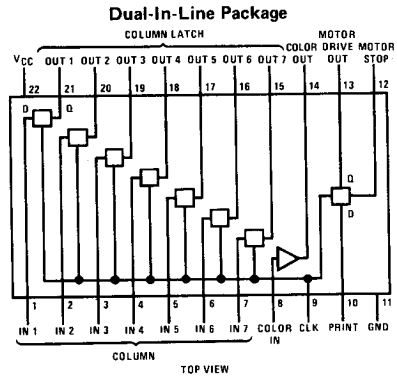

Order Number **DS8693N**
See NS Package N22A

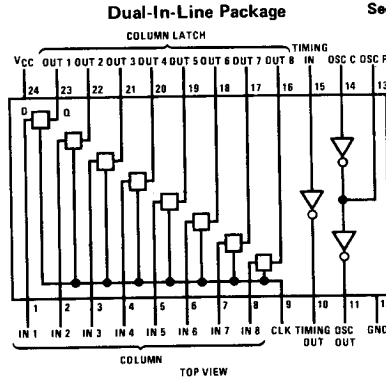

Order Number **DS8694N**
See NS Package N24A

Absolute Maximum Ratings DS8692—Transistor Array (Note 1)

Collector to Base Voltage	25V	Power Dissipation ($T_A = 25^\circ\text{C}$)	650 mW
Collector to Emitter Voltage	25V	Operating Junction Temperature	150°C max
Collector to Emitter Voltage (Note 4)	15V	Operating Temperature Range	0°C to +70°C
Emitter to Base Voltage	6V	Storage Temperature Range	-65°C to +150°C
Collector Current (Continuous)	0.4A	Lead Temperature (Soldering, 10 seconds)	300°C

Electrical Characteristics DS8692 (Notes 2 and 3)

PARAMETER	CONDITIONS	MIN	TYP	MAX	UNITS
VCEO	Collector to Emitter Breakdown Voltage $I_C = 500 \mu\text{A}, I_B = 0$	15			V
VCES	Collector to Emitter Breakdown Voltage $I_C = 1 \text{ mA}, V_{BE} = 0$	25			V
VCBO	Collector to Base Breakdown Voltage $I_C = 1 \text{ mA}, I_E = 0$	25			V
VCE(SAT)	Collector to Emitter Saturation Voltage $I_C = 350 \text{ mA}, I_B = 7.0 \text{ mA}$, (Note 7)		0.6	1.0	V
VBE(SAT)	Base to Emitter Saturation Voltage $I_C = 350 \text{ mA}, I_B = 7.0 \text{ mA}$, (Note 7)		0.8	1.05	V

Absolute Maximum Ratings DS8693 (Note 1)

Operating Conditions DS8693

Supply Voltage	12V	Supply Voltage (V_{CC})	MIN 8.5	MAX 11.0	UNITS V
Input Voltage	12V	Temperature (T_A)	0	+70	°C
Output Voltage					
All Pins Except Pin 13	12V				
Pin 13	19V				
Storage Temperature Range	-65°C to +150°C				
Maximum Power Dissipation* at 25°C					
Molded Package	1897 mW				
Lead Temperature (Soldering, 10 seconds)	300°C				

*Derate molded package 15.18 mW/°C above 25°C.

Electrical Characteristics DS8693 (Notes 2 and 3)

PARAMETER	CONDITIONS	MIN	TYP	MAX	UNITS
COLUMN DRIVERS					
I _{IN}	Input Current	V _{IN} = 2.7V	50		μA
		V _{IN} = 9.5V		250	μA
V _{OL}	Output OFF Voltage	V _{CC} = Min, V _{IN} = 2.7V, V _{CLOCK} = 3.5V, I _{OUT} = 1 mA		0.4	V
I _{OH}	Output ON Current	V _{CC} = Min, V _{IN} = 7.0V, V _{CLOCK} = 3.5V, V _{OUT} = 1.0V	-7	-17	mA
I _{OS}	Output Short Circuit Current	V _{CC} = Max, V _{IN} = 2.7V, V _{CLOCK} = 3.5V, V _{OUT} = 0V		-1.2	mA
CLOCK INPUT					
I _{IN}	Input Current	V _{IN} = 3.5V		300	μA
		V _{IN} = 1.6V	50		μA
V _{IH}	Logical "1" Input High Voltage		3.5		V
V _{IL}	Logical "0" Input Low Voltage			1.6	V
MOTOR DRIVER					
I _{IN} (PRINT)	Input Current	V _{IN} = 2.3V	50		μA
		V _{IN} = 9.5V		250	μA
I _{IL} (STOP)	Input Low Current (Stop)	V _{CC} = Min, V _{IN} (STOP) = 0.4V, (Stop Switch Closed)		-700	μA
V _{IH} (STOP)	Input High Voltage (Stop)	V _{CC} = Max, I _{IN} (STOP) = -10 μA, (Stop Switch Open)		2.5	V
V _{OL}	Output Low Voltage	V _{CC} = Min, V _{PRINT} = 7V, I _{OUT} = 15 mA		0.5	V

Electrical Characteristics (Continued) **DS8693**

PARAMETER	CONDITIONS	MIN	TYP	MAX	UNITS	
MOTOR DRIVER (Continued)						
I _{OX}	Output Leakage Current	V _{CC} = Max, V _{PRINT} = 2.3V, V _{STOP} = 0.8V, V _{OUT} = 15V		100	μA	
I _{IH(STOP)}	Logical "1" Input High Current			-10	μA	
COLOR DRIVER						
I _{IN}	Input Current	V _{IN} = 3.5V			300	μA
		V _{IN} = 1.7V		50		μA
V _{OL}	Output OFF Voltage	V _{CC} = Min, V _{IN} = 1.7V, I _{OUT} = 1 mA		0.4	V	
I _{OH}	Output ON Current	V _{CC} = Min, V _{IN} = 3.5V, V _{OUT} = 1.0V		-8	-18	mA
I _{CC(SB)}	Stand-by Supply Current, (Note 6)	V _{CC} = Max, V _{COLUMN IN/VPRINT} = 0V, V _{COLOR} = 0V, V _{CLOCK} = 3.5V			55	mA

Absolute Maximum Ratings DS8694 (Note 1)

Supply Voltage	12V
Input Voltage	
All Pins Except Pin 15	12V
Pin 15	19V
Output Voltage	12V
Storage Temperature Range	-65°C to +150°C
Maximum Power Dissipation* at 25°C	
Molded Package	2005 mW
Lead Temperature (Soldering, 10 seconds)	300°C

*Derate molded package 16.04 mW/°C above 25°C.

Operating Conditions DS8694

	MIN	MAX	UNITS
Supply Voltage (V _{CC})	8.5	11.0	V
Temperature (T _A)	0	+70	°C

Electrical Characteristics DS8694 (Notes 2 and 3)

PARAMETER	CONDITIONS	MIN	TYP	MAX	UNITS		
COLUMN DRIVER							
I _{IN}	Input Current	V _{IN} = 2.7V		50	μA		
		V _{IN} = 9.5V		250	μA		
V _{OL}	Output OFF Voltage	V _{CC} = Min, V _{IN} = 2.7V, V _{CLOCK} = 3.5V, I _{OUT} = 1 mA		0.4	V		
I _{OH}	Output ON Current	V _{CC} = Min, V _{IN} = 7.0V, V _{CLOCK} = 3.5V, V _{OUT} = 1.0V		-7	-17	mA	
I _{OS}	Output Short-Circuit Current	V _{CC} = Max, V _{IN} = 2.7V, V _{CLOCK} = 3.5V, V _{OUT} = 0V		-1.2	mA		
CLOCK INPUT							
I _{IN}	Input Current	V _{IN} = 3.5V		300	μA		
		V _{IN} = 2.7V		50	μA		
V _{IH}	Logical "1" Input High Voltage	3.5			V		
V _{IL}	Logical "0" Input Low Voltage			1.6	V		
TIMING BUFFER							
I _{IN}	Input Current	V _{IN} = 2V		-50	μA		
		V _{IN} = 17V		880	μA		
V _{OL}	Output Low Voltage	I _{OUT} = 50 μA, V _{IN} = 10V		0.5	V		
V _{OH}	Output High Voltage	I _{OUT} = -50 μA, V _{IN} = 7V		V _{CC} -1.0	V		
OSCILLATOR							
f _{OSC}	Frequency	V _{CC} = Max, R = 18k, C = 0.0015 μF, (Note 5)		85	100	115	kHz
V _{OL}	Output Low Voltage	V _{CC} = Min, I _{OUT} = 50 μA			0.5		V
V _{OH}	Output High Voltage	I _{OUT} = -50 μA		V _{CC} -1.0			V
DC	Duty Cycle	V _{CC} = Max		40	50	60	%
V _{OSC}	Osc. V _{CC} Turn ON Voltage			6.0	7.7	8.5	V
I _{CC(SB)}	Stand-by Supply Current	V _{CC} = Max, V _{COLUMN IN/VPRINT} = 0V, I _{CLOCK} = 300 μA				55	mA

Switching Characteristics DS8694V_{CC} = 5V, T_A = 25°C (unless otherwise specified)

PARAMETER		CONDITIONS	MIN	TYP	MAX	UNITS
COLUMN DRIVERS (DS8693, DS8694) (Figure 3)						
PWCOLUMN	Column In Pulse Width		1.1			μs
PWCLOCK	Clock Pulse Width		1.0			μs
t _d	Delay of Column In Pulse After Clock Transitions to Low State for Output to Latch		0.1			μs
t _{PD0}	Propagation Delay to a Logical "0" From Clock to Column Out Output	Column In = 0V			10.0	μs
t _{PD1}	Propagation Delay to a Logical "1" From Clock to Column Output	Column In = 7V			1300	μs
t _{PD0}	Propagation Delay to a Logical "0" From Column In to Column Out	Clock = 7V			10	μs
t _{PD1}	Propagation Delay to a Logical "1" From Column In to Column Out	Clock = 7V			1300	μs
COLOR DRIVER (DS8693) (Figure 4)						
t _{PD0}	Propagation Delay to a Logical "0" From Color In to Color Out				10.0	μs
t _{PD1}	Propagation Delay to a Logical "1" From Color In to Color Out				10.0	μs
MOTOR DRIVER (DS8693) (Figure 6)						
PWPRINT	Print Signal Pulse Width		1			μs
PWSTOP	Stop Signal Pulse Width		1			μs
PWCLOCK	Clock Pulse Width		1			μs
t _{PD0}	Propagation Delay to a Logical "0" From Print to Motor Drive Out				10	μs
t _{PD1}	Propagation Delay to a Logical "1" From Motor Stop (High-to-Low Transition) to Motor Drive Out	Print = 0V, Clock = 7.0V			10	μs
TIMING SIGNAL BUFFER (DS8694) (Figure 5)						
PWTIMING	Timing Signal Pulse Width		1	1000		ms
t _r	Rise Time	C _{LOAD} = 35 pF			500	ns
t _f	Fall Time	C _{LOAD} = 35 pF			500	ns
t _{PD0}	Propagation Delay to a Logical "0" From Timing In to Timing Out				10	μs
t _{PD1}	Propagation Delay to a Logical "1" From Timing In to Timing Out				10	μs
CLOCK OSCILLATOR (DS8694) (Figure 7)						
f _{OSC}	Oscillator Frequency	(Note 5)	85	100	115	kHz
DC	Duty Cycle		40	50	60	%
t _r	Rise Time	C _{LOAD} = 70 pF			500	ns
t _f	Fall Time	C _{LOAD} = 70 pF			500	ns

- Note 1:** "Absolute Maximum Ratings" are those values beyond which the safety of the device cannot be guaranteed. Except for "Operating Temperature Range" they are not meant to imply that the devices should be operated at these limits. The table of "Electrical Characteristics" provides conditions for actual device operation.
- Note 2:** Unless otherwise specified min/max limits apply across the 0°C to +70°C range for the DS8692, DS8693, DS8694. All typicals are given for $V_{CC} = 10V$ and $T_A = 25^\circ C$.
- Note 3:** All currents into device pins shown as positive, out of device pins as negative, all voltages referenced to ground unless otherwise noted. All values shown as max or min on absolute basis.
- Note 4:** Ratings refer to a high current point where collector-emitter voltage is lowest.
- Note 5:** Oscillator frequency is determined by external R between "Osc R" and "Osc C" and external C from "Osc C" to ground. $2k > R > 20k$.
- Note 6:** Column outputs operate on approximately 1/16 duty cycle in normal operation.
- Note 7:** Measured with one output on at a time.

System Connection Diagram

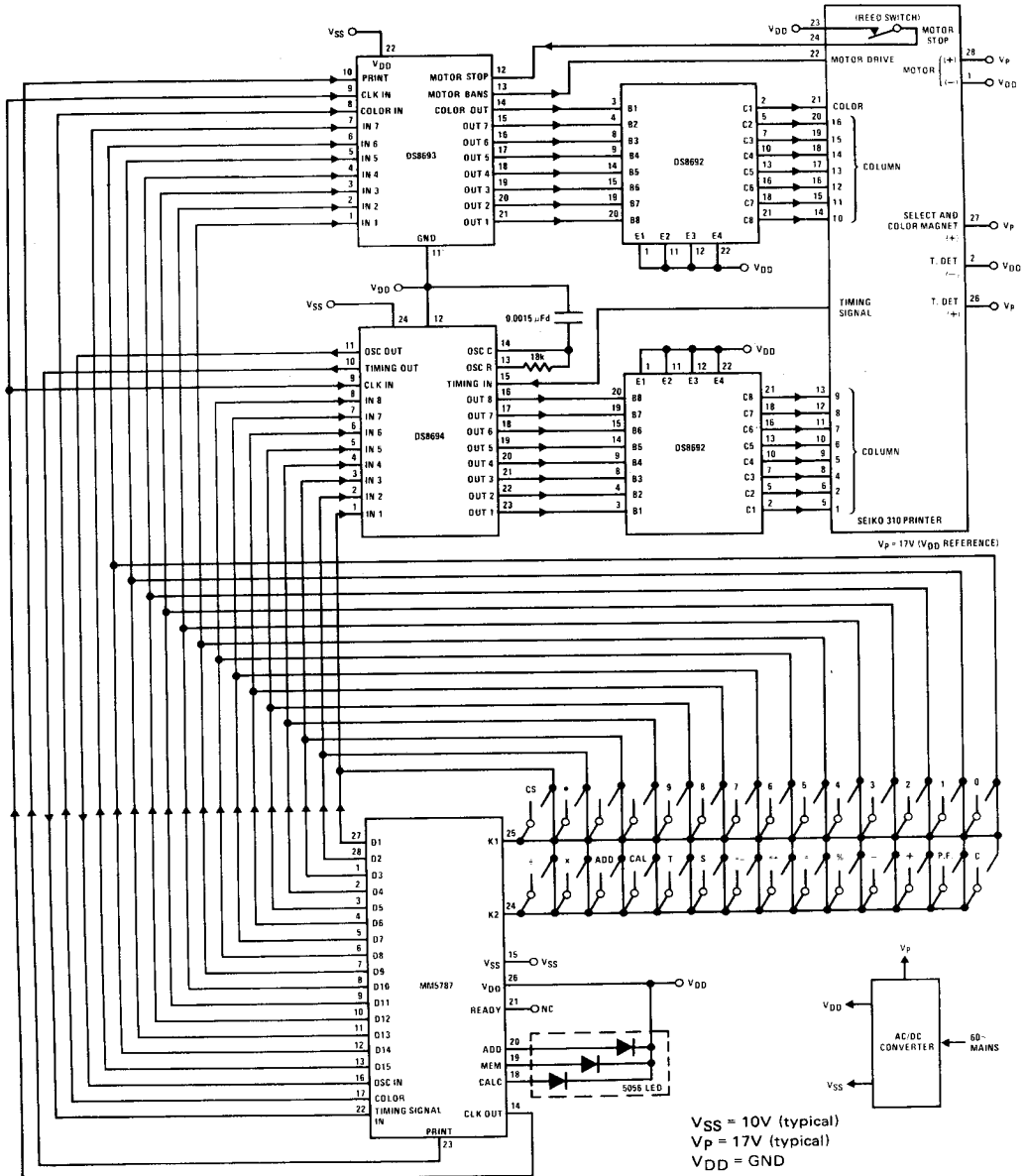
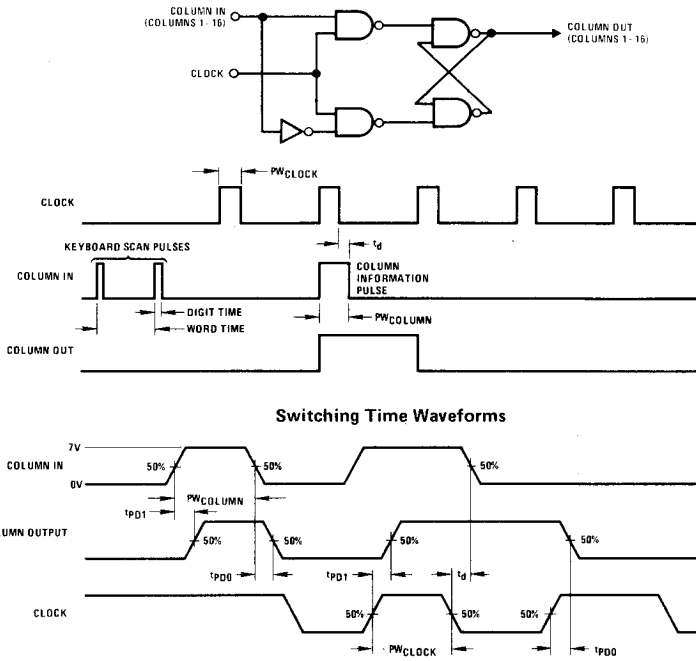

FIGURE 1

Logic and Timing Diagrams



Switching Time Waveforms

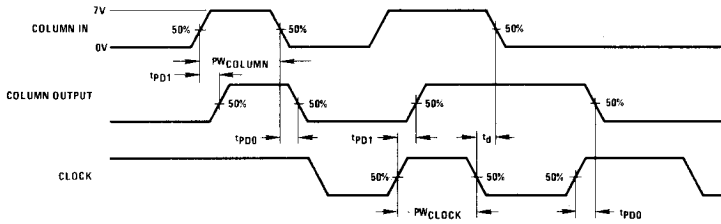

FIGURE 3. DS8693, DS8694 Column Latch

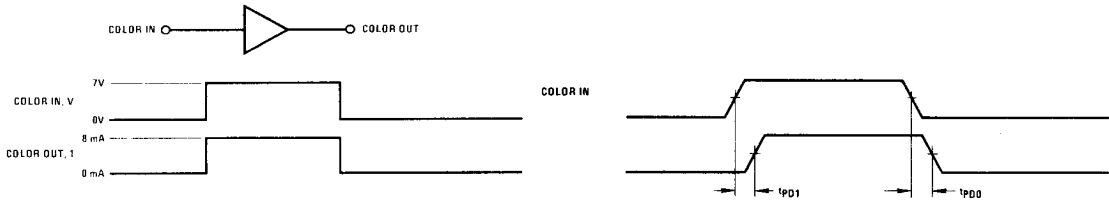

FIGURE 4. DS8693 Color Driver

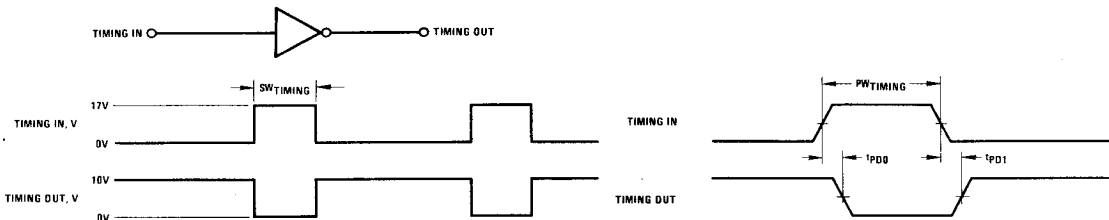
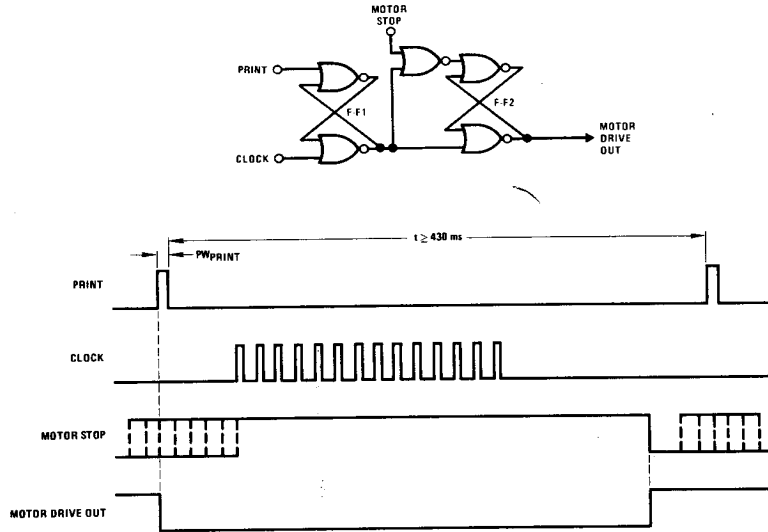

FIGURE 5. DS8694 Timing Signal Buffer

Logic and Timing Diagrams



Switching Time Waveforms

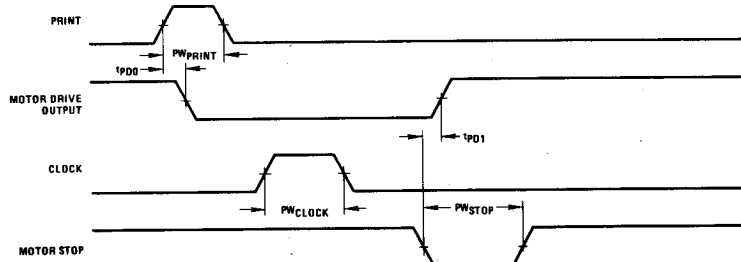

FIGURE 6. DS8693 Motor Drive Latch

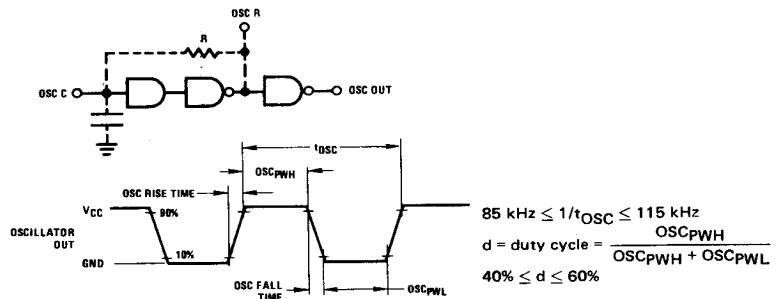

FIGURE 7. DS8694 Oscillator Diagram