

HD74LV1GW57A

Configurable Multiple-Function Gate

HITACHI

ADE-205-717 (Z)

Rev.0
Feb. 2003

Description

The HD74LV1GW57A has configurable multiple-function gate in a 6 pin package. The Output state is determined by eight patterns of 3-bit input. The user can choose the logic functions AND, NAND, NOR, EX-NOR. Low voltage and high speed operation is suitable for the battery powered products (e.g., notebook computers), and the low power consumption extends the battery life.

Features

- The basic gate function is lined up as hitachi uni logic series.
- Supplied on emboss taping for high speed automatic mounting.
- Supply voltage range : 1.65 to 5.5 V
Operating temperature range : -40 to +85°C
- All inputs V_{IH} (Max.) = 5.5 V (@ V_{CC} = 0 V to 5.5 V)
All outputs V_O (Max.) = 5.5 V (@ V_{CC} = 0 V)
- Output current ± 6 mA (@ V_{CC} = 3.0 V to 3.6 V), ± 12 mA (@ V_{CC} = 4.5 V to 5.5 V)
- All the logical input has hysteresis voltage for the slow transition.
- Ordering Information

Part Name	Package Type	Package Code	Package Abbreviation	Taping Abbreviation (Quantity)
HD74LV1GW57ACME	CMPAK-6 pin	CMPAK-6V(O)	CM	E (3,000 pcs / Reel)

Outline and Article Indication

• HD74LV1GW57A

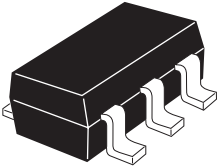

CMPAK-6

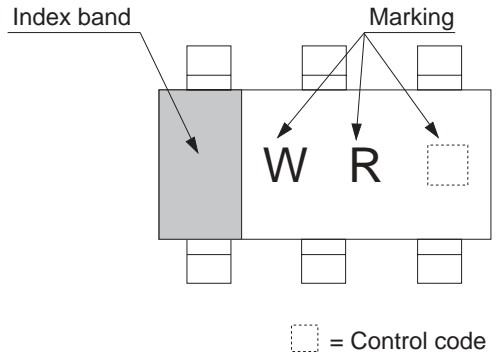

Function Table

Inputs			Output
IN2	IN1	IN0	Y
L	L	L	H
L	L	H	L
L	H	L	H
L	H	H	L
H	L	L	L
H	L	H	L
H	H	L	H
H	H	H	H

H : High level

L : Low level

Pin Arrangement

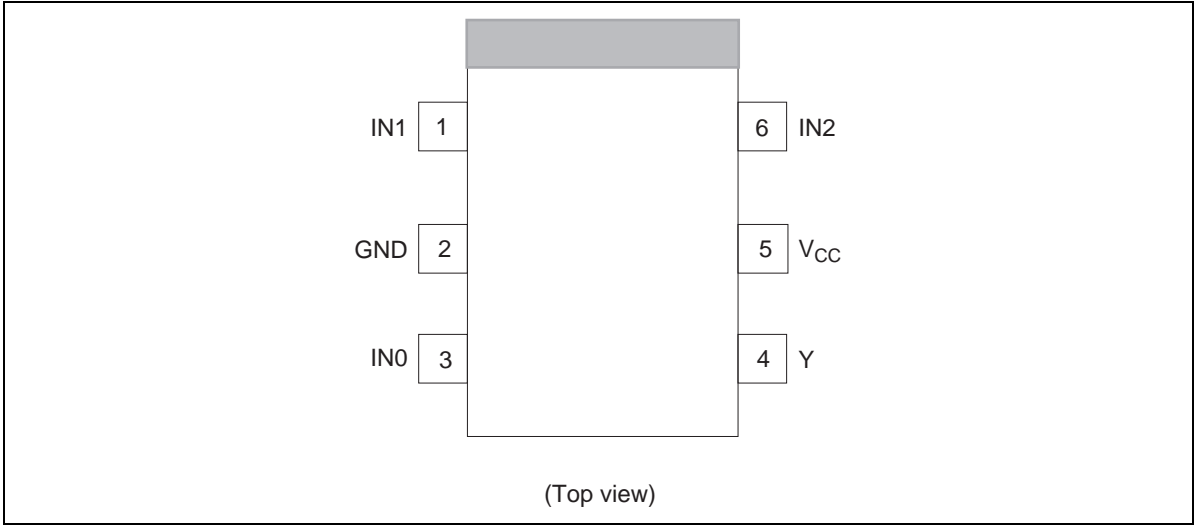

Logic Diagram

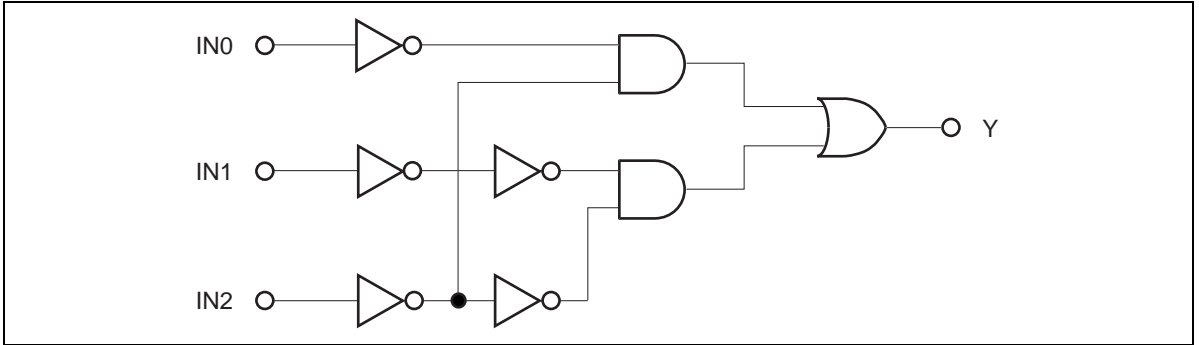

Function Selection Table

Logic Function	Figure No.
2-input AND	1
2-input AND with both inputs inverted	4
2-input NAND with one input inverted	2, 3
2-input OR with one input inverted	2, 3
2-input NOR	4
2-input NOR with both inputs inverted	1
2-input EX-NOR	5

Logic Configurations

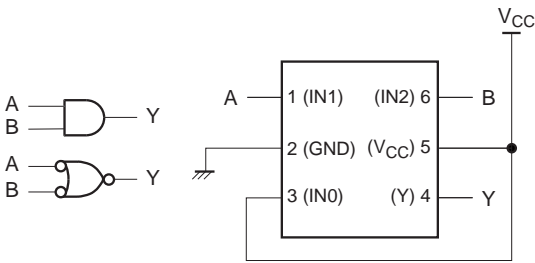

Figure 1. 2-inputs AND Gate

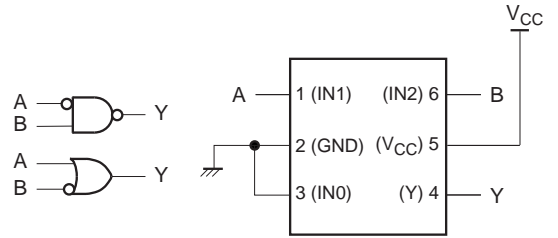

Figure 2. 2-inputs NAND Gate with A input inverted

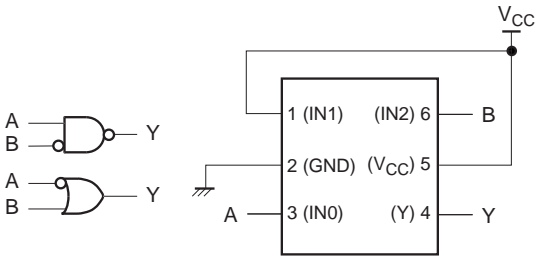

Figure 3. 2-inputs NAND Gate with B input inverted

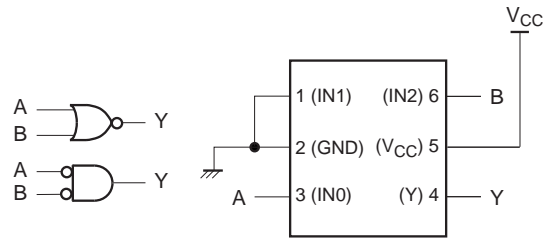

Figure 4. 2-inputs NOR Gate

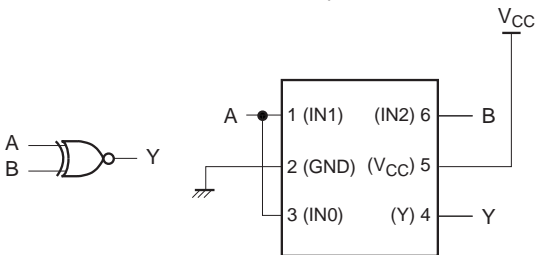

Figure 5. 2-inputs EX-NOR Gate

Absolute Maximum Ratings

Item	Symbol	Ratings	Unit	Test Conditions
Supply voltage range	V_{CC}	-0.5 to 7.0	V	
Input voltage range ^{*1}	V_I	-0.5 to 7.0	V	
Output voltage range ^{*1,2}	V_O	-0.5 to $V_{CC} + 0.5$ -0.5 to 7.0	V	Output : H or L $V_{CC} : OFF$
Input clamp current	I_{IK}	-20	mA	$V_I < 0$
Output clamp current	I_{OK}	± 50	mA	$V_O < 0$ or $V_O > V_{CC}$
Continuous output current	I_O	± 25	mA	$V_O = 0$ to V_{CC}
Continuous current through V_{CC} or GND	I_{CC} or I_{GND}	± 50	mA	
Maximum power dissipation at $T_a = 25^\circ C$ (in still air) ^{*3}	P_T	200	mW	
Storage temperature	T_{stg}	-65 to 150	$^\circ C$	

Notes: The absolute maximum ratings are values which must not individually be exceeded, and furthermore no two of which may be realized at the same time.

1. The input and output voltage ratings may be exceeded if the input and output clamp-current ratings are observed.
2. This value is limited to 5.5 V maximum.
3. The maximum package power dissipation was calculated using a junction temperature of 150°C.

Recommended Operating Conditions

Item	Symbol	Min	Max	Unit	Conditions
Supply voltage range	V_{CC}	1.65	5.5	V	
Input voltage range	V_I	0	5.5	V	
Output voltage range	V_O	0	V_{CC}	V	
Output current	I_{OL}	—	1	mA	$V_{CC} = 1.65$ to 1.95 V
		—	2		$V_{CC} = 2.3$ to 2.7 V
		—	6		$V_{CC} = 3.0$ to 3.6 V
		—	12		$V_{CC} = 4.5$ to 5.5 V
	I_{OH}	—	-1		$V_{CC} = 1.65$ to 1.95 V
		—	-2		$V_{CC} = 2.3$ to 2.7 V
		—	-6		$V_{CC} = 3.0$ to 3.6 V
		—	-12		$V_{CC} = 4.5$ to 5.5 V
Input transition rise or fall rate	$\Delta t / \Delta v$	0	300	ns / V	$V_{CC} = 1.65$ to 1.95 V
		0	200		$V_{CC} = 2.3$ to 2.7 V
		0	100		$V_{CC} = 3.0$ to 3.6 V
		0	20		$V_{CC} = 4.5$ to 5.5 V
Operating free-air temperature	T_a	-40	85	°C	

Note: Unused or floating inputs must be held high or low.

Electrical Characteristic

- $T_a = -40$ to 85°C

Item	Symbol	V_{CC} (V) *	Min	Typ	Max	Unit	Test condition	
Threshold voltage	V_{T^+}	1.65 to 1.95	—	—	$V_{CC} \times 0.75$	V		
		2.5	—	—	1.75			
		3.3	—	—	2.31			
		5.0	—	—	3.50			
	V_{T^-}	1.65 to 1.95	$V_{CC} \times 0.25$	—	—			
		2.5	0.75	—	—			
		3.3	0.99	—	—			
		5.0	1.5	—	—			
	ΔV_T	1.65 to 1.95	0.1	—	—	$V_{CC} \times 0.4$		
		2.5	0.25	—	—	1.0		
		3.3	0.33	—	—	1.32		
		5.0	0.5	—	—	2.0		
Output voltage	V_{OH}	Min to Max	$V_{CC} - 0.1$	—	—	V	$I_{OH} = -50 \mu\text{A}$	
		1.65	1.4	—	—		$I_{OH} = -1 \text{ mA}$	
		2.3	2.0	—	—		$I_{OH} = -2 \text{ mA}$	
		3.0	2.48	—	—		$I_{OH} = -6 \text{ mA}$	
		4.5	3.8	—	—		$I_{OH} = -12 \text{ mA}$	
	V_{OL}	Min to Max	—	—	0.1		$I_{OL} = 50 \mu\text{A}$	
		1.65	—	—	0.3		$I_{OL} = 1 \text{ mA}$	
		2.3	—	—	0.4		$I_{OL} = 2 \text{ mA}$	
		3.0	—	—	0.44		$I_{OL} = 6 \text{ mA}$	
		4.5	—	—	0.55		$I_{OL} = 12 \text{ mA}$	
Input current	I_{IN}	0 to 5.5	—	—	± 1	μA	$V_{IN} = 5.5 \text{ V or GND}$	
Quiescent supply current	I_{CC}	5.5	—	—	10	μA	$V_{IN} = V_{CC}$ or GND , $I_O = 0$	
Output leakage current	I_{OFF}	0	—	—	5	μA	V_{IN} or $V_O = 0$ to 5.5 V	
Input capacitance	C_{IN}	3.3	—	3.0	—	pF	$V_{IN} = V_{CC}$ or GND	

Note: For conditions shown as Min or Max, use the appropriate values under recommended operating conditions.

Switching Characteristics

- $V_{CC} = 1.8 \pm 0.15 \text{ V}$

Item	Symbol	Ta = 25°C			Ta = -40 to 85°C		Unit	Test Conditions	FROM (Input)	TO (Output)
		Min	Typ	Max	Min	Max				
Propagation delay time	t _{PLH}	—	15.8	29.4	1.0	33.0	ns	C _L = 15 pF	IN	Y
	t _{PHL}	—	22.6	40.9	1.0	45.0				

- $V_{CC} = 2.5 \pm 0.2 \text{ V}$

Item	Symbol	Ta = 25°C			Ta = -40 to 85°C		Unit	Test Conditions	FROM (Input)	TO (Output)
		Min	Typ	Max	Min	Max				
Propagation delay time	t _{PLH}	—	9.4	17.6	1.0	21.0	ns	C _L = 15 pF	IN	Y
	t _{PHL}	—	12.6	22.6	1.0	26.5				

- $V_{CC} = 3.3 \pm 0.3 \text{ V}$

Item	Symbol	Ta = 25°C			Ta = -40 to 85°C		Unit	Test Conditions	FROM (Input)	TO (Output)
		Min	Typ	Max	Min	Max				
Propagation delay time	t _{PLH}	—	7.0	11.0	1.0	13.0	ns	C _L = 15 pF	IN	Y
	t _{PHL}	—	9.5	14.5	1.0	16.5				

- $V_{CC} = 5.0 \pm 0.5 \text{ V}$

Item	Symbol	Ta = 25°C			Ta = -40 to 85°C		Unit	Test Conditions	FROM (Input)	TO (Output)
		Min	Typ	Max	Min	Max				
Propagation delay time	t _{PLH}	—	4.8	6.8	1.0	8.0	ns	C _L = 15 pF	IN	Y
	t _{PHL}	—	6.3	8.8	1.0	10.0				

Operating Characteristics

- C_L = 50 pF

Item	Symbol	V _{CC} (V)	Ta = 25°C			Unit	Test Conditions
			Min	Typ	Max		
Power dissipation capacitance	C _{PD}	3.3	—	8.5	—	pF	f = 10 MHz
			5.0	—	10.0		

Test Circuit

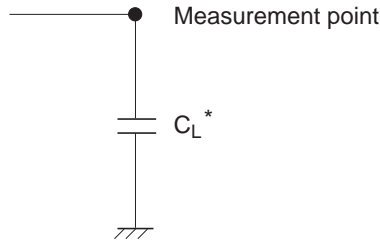

Note: C_L includes probe and jig capacitance.

• Waveforms

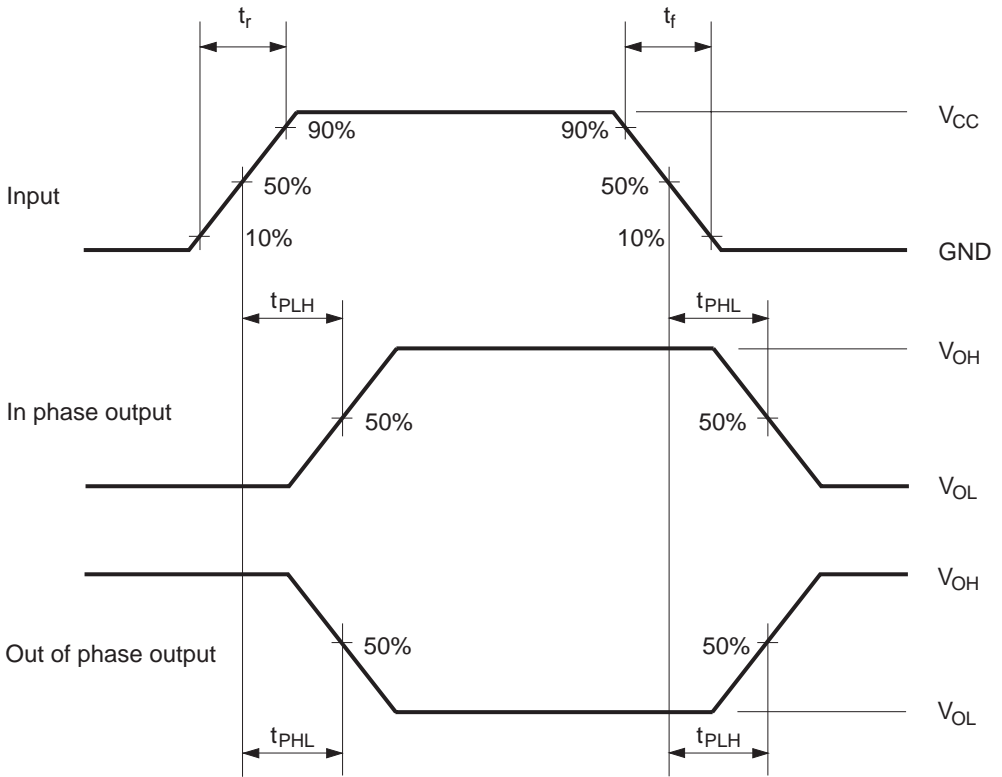

- Notes: 1. Input waveform : $PRR \leq 1 \text{ MHz}$, $Z_o = 50 \Omega$, $t_r \leq 3 \text{ ns}$, $t_f \leq 3 \text{ ns}$.
 2. The output are measured one at a time with one transition per measurement.

Package Dimensions

Unit: mm

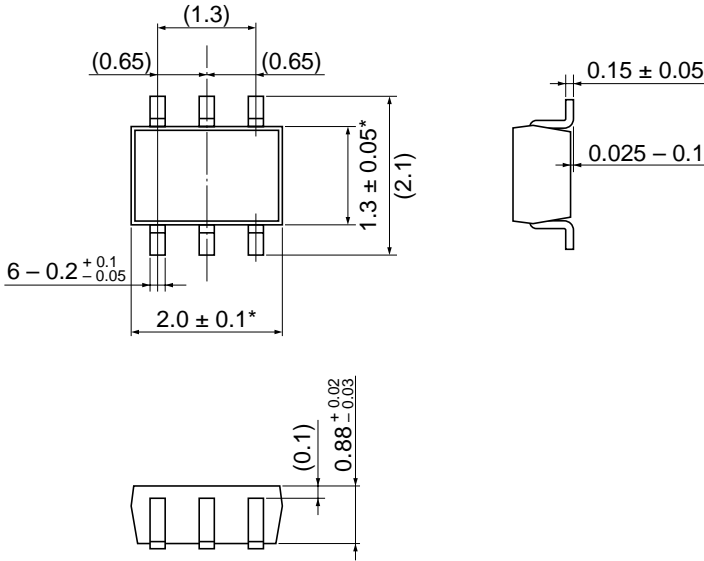

* Sn-Bi plating.

** The value does not include Resin Bar.
(One side: 0.15 mm (max))

Hitachi Code	CMPAK-6V(O)
JEDEC	—
JEITA	Conforms
Mass (reference value)	0.006 g

Disclaimer

1. Hitachi neither warrants nor grants licenses of any rights of Hitachi's or any third party's patent, copyright, trademark, or other intellectual property rights for information contained in this document. Hitachi bears no responsibility for problems that may arise with third party's rights, including intellectual property rights, in connection with use of the information contained in this document.
2. Products and product specifications may be subject to change without notice. Confirm that you have received the latest product standards or specifications before final design, purchase or use.
3. Hitachi makes every attempt to ensure that its products are of high quality and reliability. However, contact Hitachi's sales office before using the product in an application that demands especially high quality and reliability or where its failure or malfunction may directly threaten human life or cause risk of bodily injury, such as aerospace, aeronautics, nuclear power, combustion control, transportation, traffic, safety equipment or medical equipment for life support.
4. Design your application so that the product is used within the ranges guaranteed by Hitachi particularly for maximum rating, operating supply voltage range, heat radiation characteristics, installation conditions and other characteristics. Hitachi bears no responsibility for failure or damage when used beyond the guaranteed ranges. Even within the guaranteed ranges, consider normally foreseeable failure rates or failure modes in semiconductor devices and employ systemic measures such as fail-safes, so that the equipment incorporating Hitachi product does not cause bodily injury, fire or other consequential damage due to operation of the Hitachi product.
5. This product is not designed to be radiation resistant.
6. No one is permitted to reproduce or duplicate, in any form, the whole or part of this document without written approval from Hitachi.
7. Contact Hitachi's sales office for any questions regarding this document or Hitachi semiconductor products.

Sales Offices

HITACHI

Hitachi, Ltd.

Semiconductor & Integrated Circuits
 Nippon Bldg., 2-6-2, Ohte-machi, Chiyoda-ku, Tokyo 100-0004, Japan
 Tel: (03) 3270-2111 Fax: (03) 3270-5109

URL <http://www.hitachisemiconductor.com/>

For further information write to:

Hitachi Semiconductor (America) Inc.
 179 East Tasman Drive
 San Jose, CA 95134
 Tel: <1> (408) 433-1990
 Fax: <1> (408) 433-0223

Hitachi Europe Ltd.
 Electronic Components Group
 Whitebrook Park
 Lower Cookham Road
 Maidenhead
 Berkshire SL6 8YA, United Kingdom
 Tel: <44> (1628) 585000
 Fax: <44> (1628) 778322

Hitachi Asia Ltd.
 Hitachi Tower
 16 Collyer Quay #20-00
 Singapore 049318
 Tel: <65>-6538-6533/6538-8577
 Fax: <65>-6538-6933/6538-3877
 URL: <http://semiconductor.hitachi.com.sg>

Hitachi Asia (Hong Kong) Ltd.
 Group III (Electronic Components)
 7/F., North Tower
 World Finance Centre,
 Harbour City, Canton Road
 Tsim Sha Tsui, Kowloon Hong Kong
 Tel: <852>-2735-9218
 Fax: <852>-2730-0281
 URL: <http://semiconductor.hitachi.com.hk>

Hitachi Europe GmbH
 Electronic Components Group
 Dornacher Str 3
 D-85622 Feldkirchen
 Postfach 201, D-85619 Feldkirchen
 Germany
 Tel: <49> (89) 9 9180-0
 Fax: <49> (89) 9 29 30 00

Hitachi Asia Ltd.
 (Taipei Branch Office)
 4/F, No. 167, Tun Hwa North Road
 Hung-Kuo Building
 Taipei (105), Taiwan
 Tel: <886>-(2)-2718-3666
 Fax: <886>-(2)-2718-8180
 Telex: 23222 HAS-TP
 URL: <http://semiconductor.hitachi.com.tw>

Copyright © Hitachi, Ltd., 2003. All rights reserved. Printed in Japan.

Colophon 7.0