

INTRODUCTION:

Adam Tech Production Sockets perform a valuable function at a very low cost. They eliminate the need to solder expensive components directly to the PC board. Added advantages include the ability to replace components during repair, reprogramming, and expansion. Our sockets are a low profile design using high pressure dual wipe contacts that conform to EIA RS415 and MIL-S-83734 standards. These high pressure wiping contacts ensure constant continuity and low resistance. The insulators feature wide entry areas for easy lead insertion, an anti-overstress contact stop and a closed bottom to eliminate solder wicking, bridging and contact area contamination.

FEATURES:

- Low profile heights
- Dual wipe high pressure contacts
- Wide entry area for easy lead insertion
- Auto-insertion compatible
- Visual and mechanical polarization on IC Sockets
- Anti-overstress contact design

MATING OPTIONS:

Mates with all integrated circuits or components in DIP, SIP and ZIP packages.

SPECIFICATIONS:

Material:

Insulator: Polybutylene Terephthalate (PBT), glass reinforced, thermoplastic, rated UL 94V-0

Contacts: Phosphor Bronze

Plating:

100 μ m bright tin-lead plate to MIL-T-10727, Type 1 over 50 μ m copper underplate to MIL-C-14550

Electrical:

Operation voltage: 250 VAC max

Current rating: 1 Amp max

Contact resistance: 20 m Ω max

Insulation resistance: 5000 M Ω min @ 1000 VDC between adjacent contacts (75° F and 50% R.H.)

Dielectric withstanding voltage: 1000 VAC min rms (sea level)

Capacitance: .5 pF max between adjacent centers

Mechanical:

Insertion force: 325 gms max per contact

Withdrawal force: 24 gms min per contact

Environmental:

Operating temperature: -65°C to +125°C

PACKAGING:

Anti-static plastic tubes

APPROVALS AND CERTIFICATIONS:

Recognized under the component program

of Underwriters Laboratories, Inc. No. E167232

Certified by Canadian Standards Association No. LR 75112

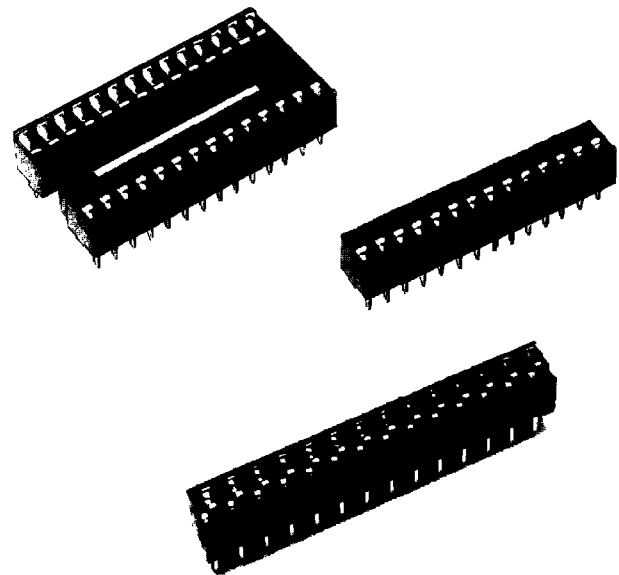

ORDERING INFORMATION

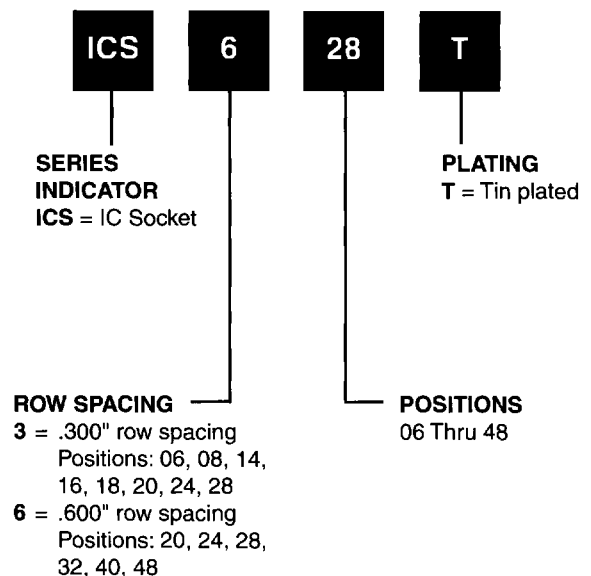

OPTIONS:

Add as suffix to basic part number

OF = Open Frame without center bar

.300" Row Centerline Socket
Positions: 6, 8, 14, 16, 18, 20, 24, 28

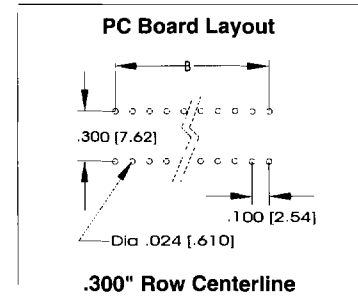
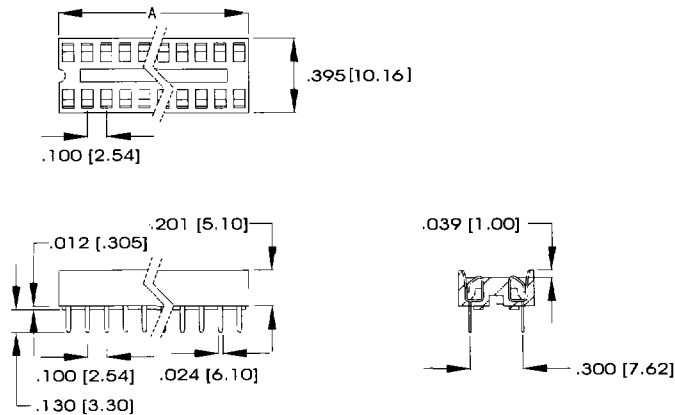

.600" Row Centerline Socket
Positions: 20, 24, 28, 32, 40, 48

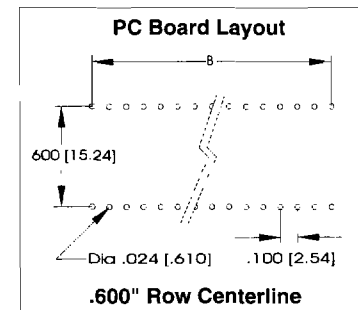
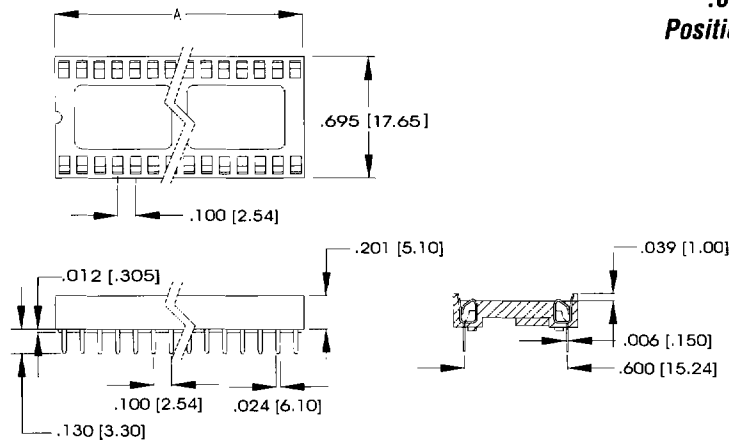

A = .100 x No. of Positions Per Row

.300" ROW CENTERLINE

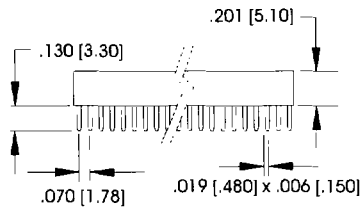
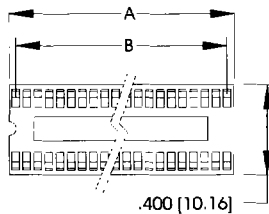

A = .070 [1.78] x No. of Positions Per Row
 B = .070 [1.78] x No. of Spaces

Specifications on Page 118

ORDERING INFORMATION

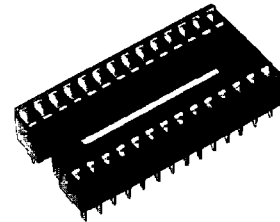
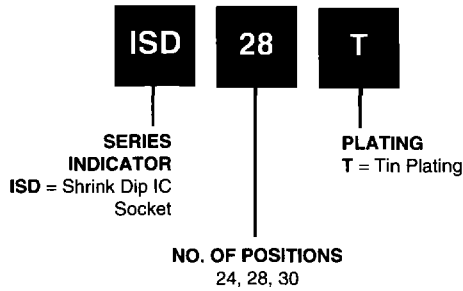

PC Board Layout

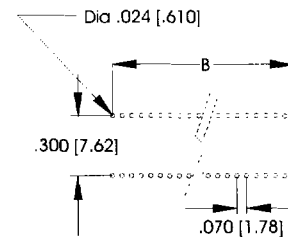

.600" ROW CENTERLINE

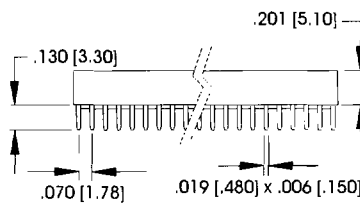
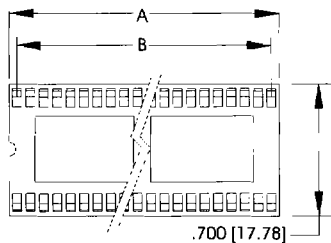

A = .070 [1.78] x No. of Positions Per Row
 B = .070 [1.78] x No. of Spaces

Specifications on Page 118

ORDERING INFORMATION

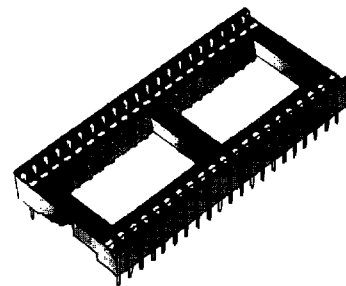
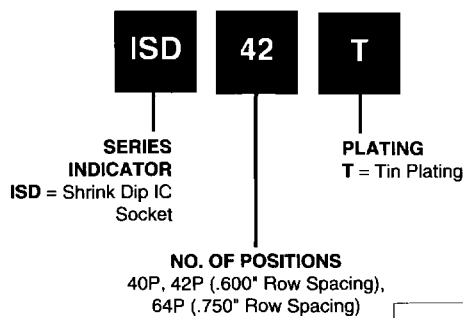

PC Board Layout

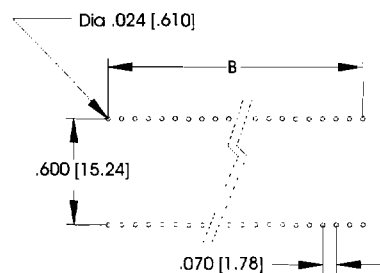

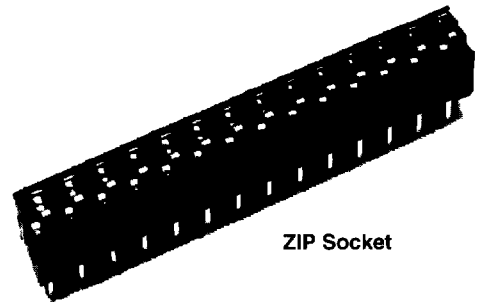
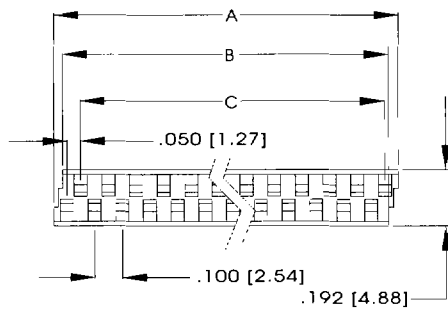

ZIP Socket

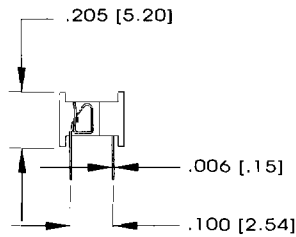
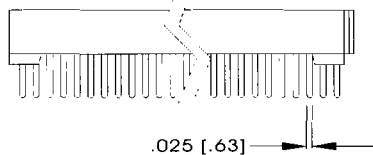

A = .050" [1.27] x No. of Positions + .016" [.406]
 B = .050" [1.27] x No. of Positions
 C = .050" [1.27] x No. of Spaces

Specifications on Page 118

ORDERING INFORMATION

ZIP **28** **T**

SERIES INDICATOR
 ZIP = Staggered Socket

PLATING
 T = Tin Plated

POSITIONS
 16, 18, 20, 24, 28, 40

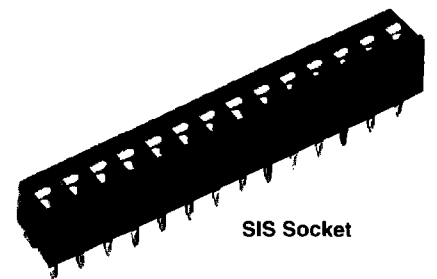
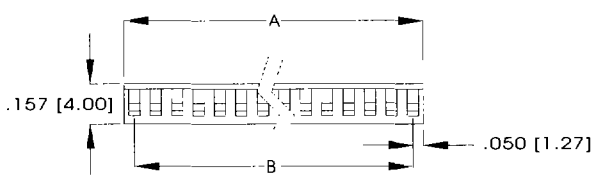
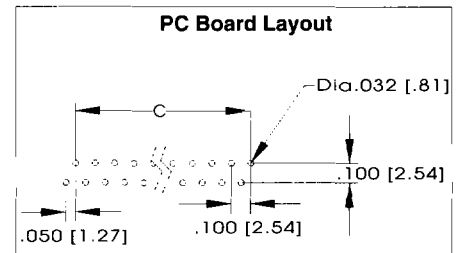

SIS Socket

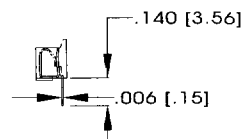
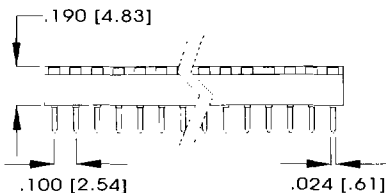

A = .100" [2.54] x No. of Positions
 B = .100" [2.54] x No. of Spaces

Specifications on Page 118

ORDERING INFORMATION

SIS **14** **T**

SERIES INDICATOR
 SIS = Single In Line Socket

PLATING
 T = Tin Plated

POSITIONS
 02 thru 20

