

3-Input / 1-Output Stereo Audio Selector

■ GENERAL DESCRIPTION

The **NJM2753** is 3-Input / 1-Output Stereo Audio Selector.

The **NJM2753** consists of switches and buffer operational amplifiers.

Based on the internal switch op-amp technology, the **NJM2753** features lower output noise, lower distortion and higher channel separation than the general Multiplexers or Analogue Switches.

The **NJM2753** contains compatibility with NJM2752(2in-1out SW), NJM2755(4in-1out SW).

■ PACKAGE OUTLINE

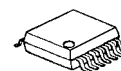

NJM2753V

■ APPLICATIONS

- LCD-TV/PDP-TV
- Car Stereo
- Any Audio System

■ FEATURES

- Operating Voltage 4.7 to 10V
- 3-Input / 1-Output Audio Selector
- Dual Channel for Stereo Use
- Low Output Noise -114dBV typ.
- Low Distortion 0.0009% typ.
- Bipolar Technology
- Package Outline SSOP14

■ BLOCK DIAGRAM

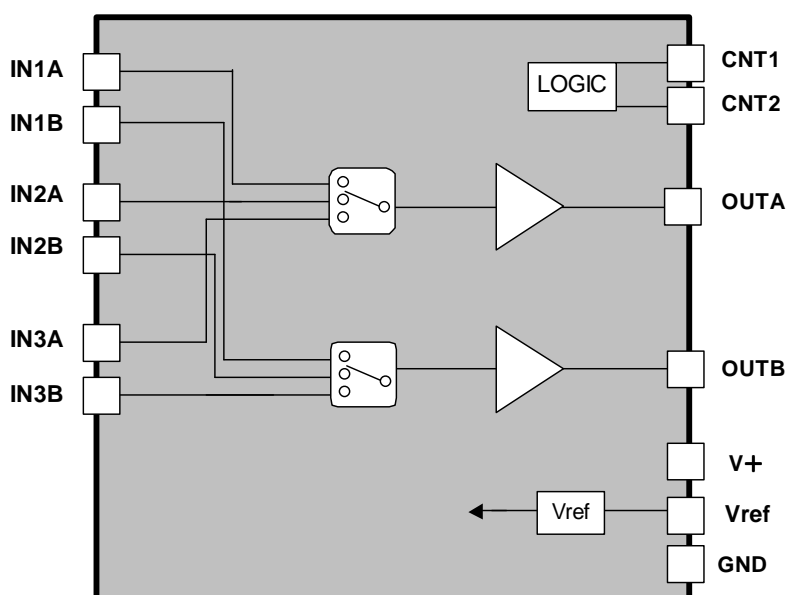

NJM2753

■ PIN CONFIGURATIONS
 NJM2752/NJM2753/NJM2755

NJM2752(SSOP14)

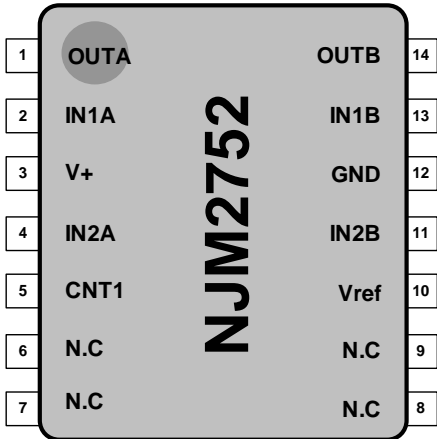

NJM2753(SSOP14)

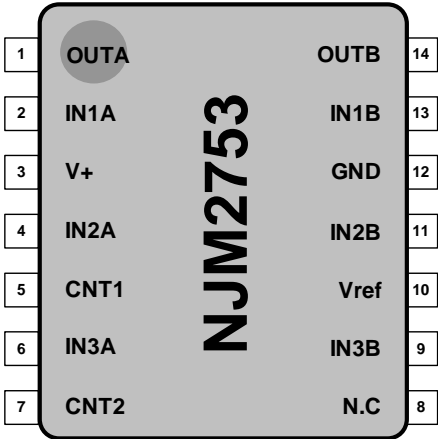

NJM2755(SSOP16)

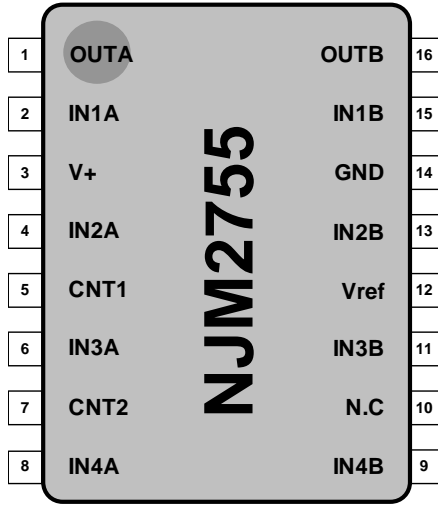

NJM2752(TVSP10)

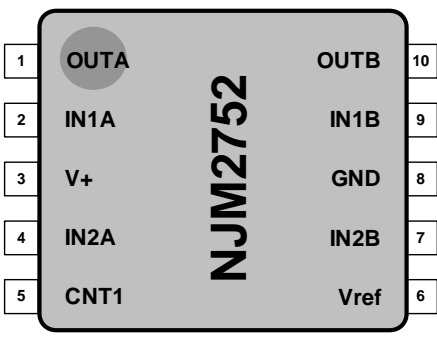

Note) This is not a final specification. Some parametric limits are subject to change without notice at any time.

■ ABSOLUTE MAXIMUM RATINGS (Ta=25°C)

PARAMETER	SYMBOL	RATING	UNIT
Supply Voltage	V ⁺	12	V
Power Dissipation	P _D	SSOP14 450 ¹⁾ 570 ²⁾ <small>NOTE 1): EIA/JEDEC STANDARD Test board (76.2x114.3x1.6mm, 2layer, FR-4) mounting 2): EIA/JEDEC STANDARD Test board (76.2x114.3x1.6mm, 4layer, FR-4) mounting</small>	mW
Operating Temperature Range	T _{OPR}	-40 to +85	°C
Storage Temperature Range	T _{STR}	-40 to +150	°C

■ ELECTRICAL CHARACTERISTICS (Ta=25°C, V⁺=9V)

PARAMETER	SYMBOL	TEST CONDITION	MIN.	TYP.	MAX.	UNIT
Operating Voltage	V ⁺		4.7	9.0	10	V
Supply Current	I _{CC}	No Signal	-	10	15	mA
Reference Voltage	V _{REF}		-	4.5	-	V
Voltage Gain	G _V	V _{in} =1V _{rms} , f=1kHz	-1	0	1	dB
Total Harmonic Distortion	THD+N	V _{in} =1V _{rms} , f=1kHz	-	0.0009	0.03	%
Output Noise Voltage	V _{NO}	A-Weighted	-	-114 (2)	-100 (10)	dBV (μV _{rms})
Maximum Output Voltage	V _{OM}	f=1kHz, THD=1%	6 (2.0)	8 (2.5)	-	dBV (V _{rms})
Cross Talk	CT	V _{in} =1V _{rms} , f=1kHz, A-Weighted	70	100	-	dB
Channel Separation	CS	V _{in} =1V _{rms} , f=1kHz, A-Weighted	80	110	-	dB
Switch-ON Voltage Level	V _{CH}		2.4	-	-	V
Switch-OFF Voltage Level	V _{CL}		-	-	0.5	V
Input Impedance	R _{IN}		-	100	-	kΩ
Output Impedance	R _{OUT}		-	45	-	Ω

■ SWITCH CONTROL LOGIC

CNT2	CNT1	INPUT SELECTOR Ach / Bch
L	L	1
L	H	2
H	L	3

MEASUREMENT CIRCUIT

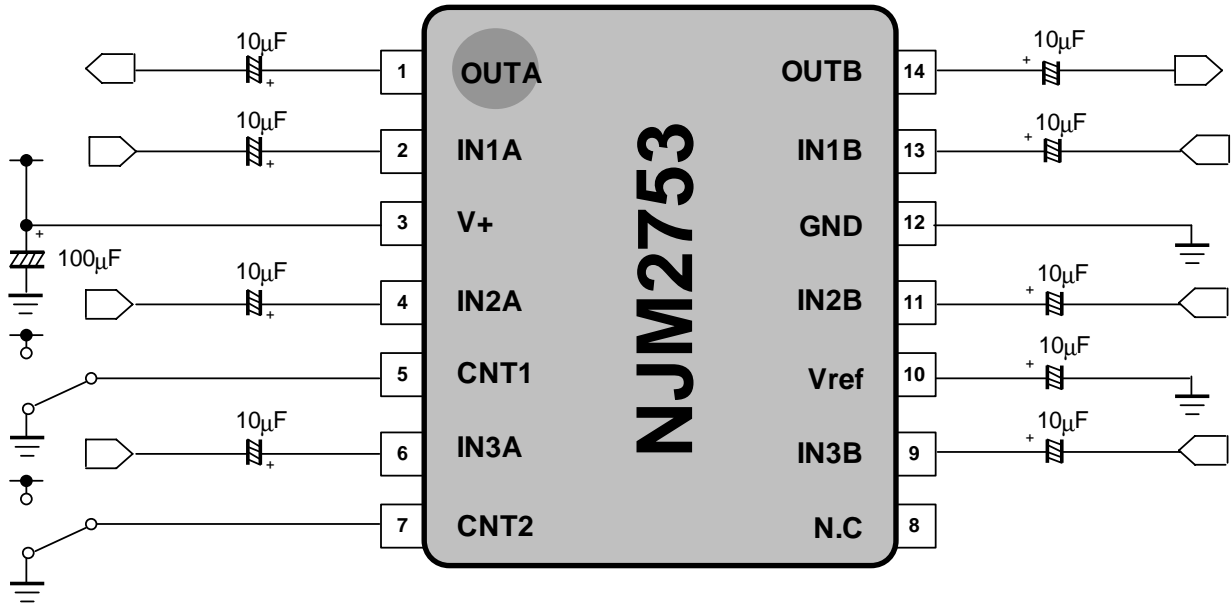

APPLICATION CIRCUIT

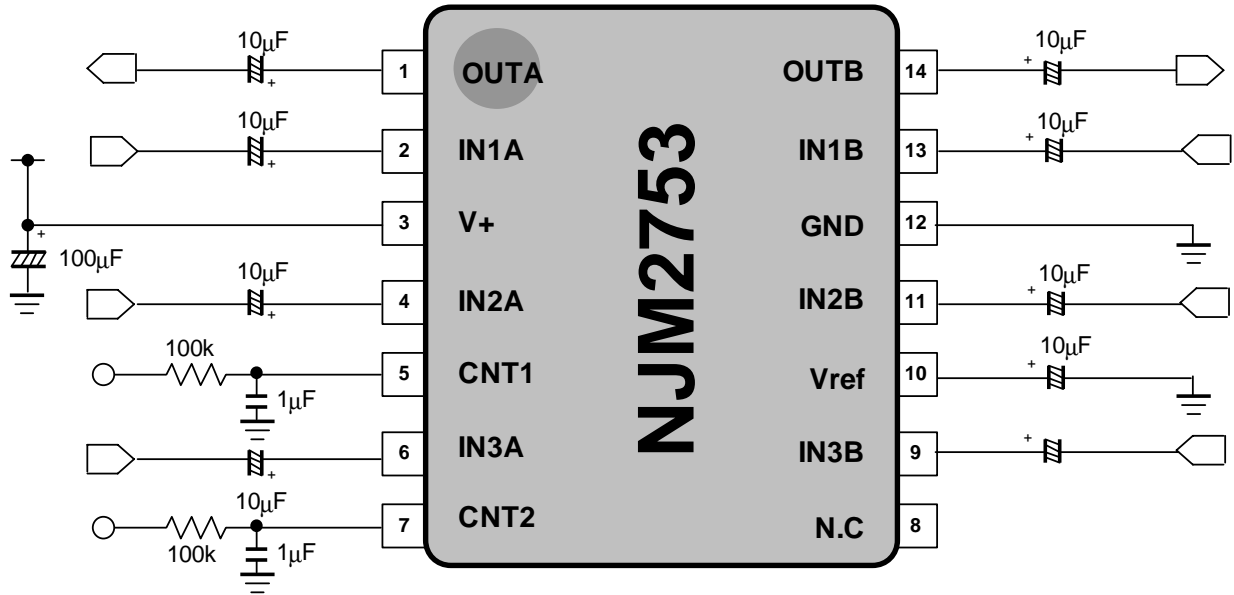

[CAUTION]
 The specifications on this databook are only given for information, without any guarantee as regards either mistakes or omissions. The application circuits in this databook are described only to show representative usages of the product and not intended for the guarantee or permission of any right including the industrial rights.