

1

2

3

4

5

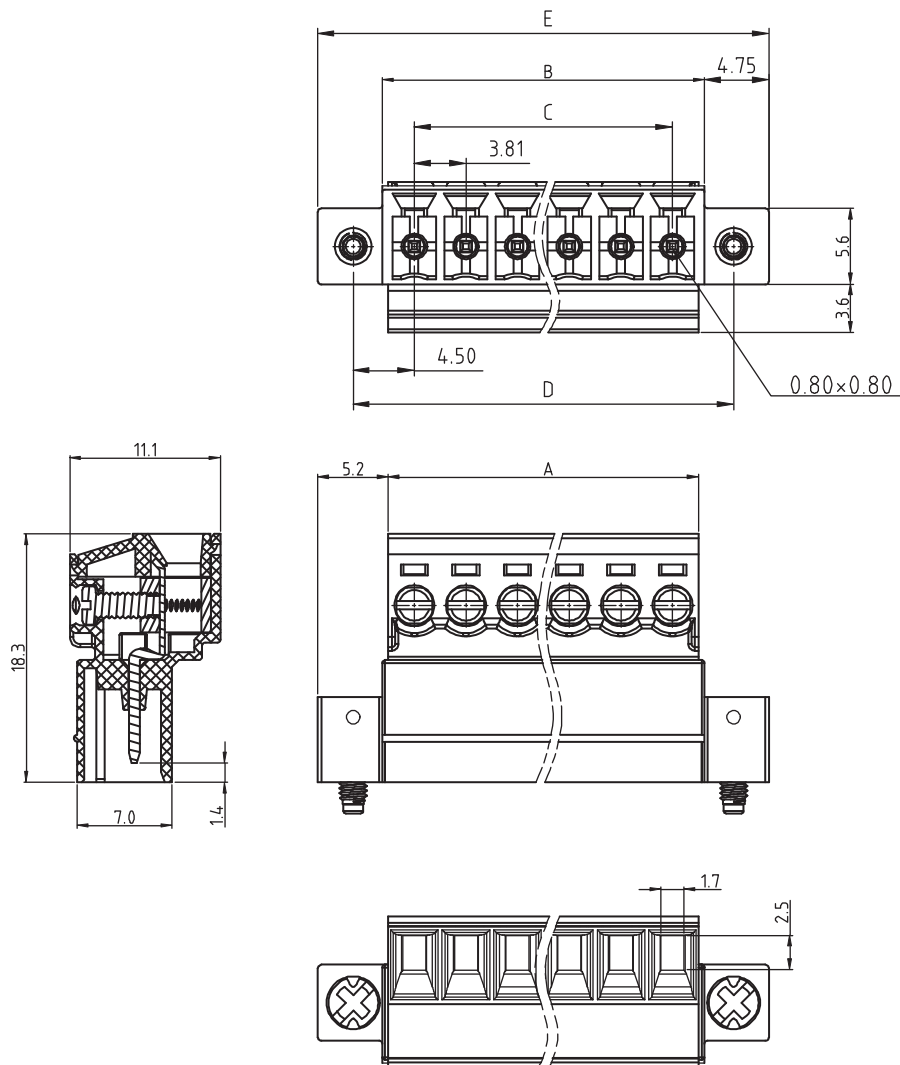

TECHNICAL CHARACTERISTICS

MATERIAL
 INSULATOR: PA 66
 FLAMABILITY RATING: UL94-V0
 COLOR: GREEN
 CONTACT MATERIAL: BRASS
 CONTACT PLATING: TIN
 CONTACT TYPE: STAMPED
 TERMINAL SCREW: STEEL ZINC PLATING
 FLANGES SCREW: STEEL M2.5

ENVIRONMENTAL
 OPERATING TEMPERATURE: -40 UP TO 115°C
 COMPLIANCE: LEAD FREE AND ROHS

ELECTRICAL
 CURRENT RATING: 8A
 WORKING VOLTAGE: 300VAC
 WITHSTANDING VOLTAGE: 1.6KV
 CONTACT RESISTANCE: 20 mOhm max

STANDARD
 ULus CERTIFIED E315414

MECHANICAL
 SOLID WIRE: 30-14 AWG / 0.051-2.08 MM²
 STRANDED WIRE: 30-14 AWG / 0.051-2.08 MM²
 TORQUE: 2.6Lb-In / 0.29Nm

WIRE STRIPE LENGTH: 7 MM
 SCREW: M2.0
 PITCH: 3.81 MM

SOLDERING
 JEDEC LEAD FREE WAVE SOLDERING PROCESS

PACKAGING
 BOX

DIMENSION
 A = 3.81 x NB PINS
 B = (3.81 x NB PINS) + 0.88
 C = 3.81 x (NB PINS-1)
 D = C + 9
 E = A + 10.4

RoHS Compliant

PROJECTION:



GENERAL TOLERANCE

.X = +/- 0.2

.XX = +/- 0.15



APPROVAL: FBr

UNIT: MM

SCALE:

SHEET: 1/2

DRAW: AK

DESCRIPTION: SERIE 3493 - 3.81 MM REVERSED PLUG VERTICAL ENTRY WITH FLANGES

WERI PART NO: 691 349 340 0xx

SIZE

A4

G			
F			
E			
D			
C			
B			
A	11-JUN-15	PDF	AK
REV	DATE	FILE	BY

1

2

3

4

5

Cautions and Warnings:

This electronic component is designed and developed with the intention for use in general electronics equipments.



Before incorporating the components into any equipments in the field such as aerospace, aviation, nuclear control, submarine, transportation, (automotive control, train control, ship control), transportation signal, disaster prevention, medical, public information network etc. where higher safety and reliability are especially required or if there is possibility of direct damage or injury to human body, Würth Elektronik must be asked for a written approval.

In addition, even electronic component in general electronic equipments, when used in electrical circuits that require high safety, reliability functions or performance, the sufficient reliability evaluation-check for the safety must be performed before by the user before usage.

A

B

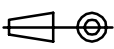
C

RoHS Compliant				PROJECTION: 	GENERAL TOLERANCE .X = +/- 0.2 .XX = +/- 0.15	 WÜRTH ELEKTRONIK	DESCRIPTION: DISCLAIMER	SIZE A4
G								
F								
E								
D								
C				APPROVAL: JC	UNIT: MM	WERI PART NO: DISCLAIMER	SIZE A4	
B				SCALE:				
A	10-SEP-14	PDF	QL	SHEET: 2/2				
REV	DATE	FILE	BY	DRAW: QL				

D