

## CDCLVP111 Low-Voltage 1:10 LVPECL With Selectable Input Clock Driver

### 1 Features

- Distributes One Differential Clock Input Pair LVPECL to 10 Differential LVPECL
- Fully Compatible With LVECL and LVPECL
- Supports a Wide Supply Voltage Range from 2.375 V to 3.8 V
- Selectable Clock Input Through CLK\_SEL
- Low-Output Skew (Typical 15 ps) for Clock-Distribution Applications
  - Additive Jitter Less Than 1 ps
  - Propagation Delay Less Than 350 ps
  - Open Input Default State
  - LVDS, CML, SSTL Input Compatible
- $V_{BB}$  Reference Voltage Output for Single-Ended Clocking
- Available in a 32-Pin LQFP and QFN Package
- Frequency Range From DC to 3.5 GHz
- Pin-to-Pin Compatible With MC100 Series EP111, ES6111, LVEP111, PTN1111

### 2 Applications

- Designed for Driving 50- $\Omega$  Transmission Lines
- High Performance Clock Distribution

### 3 Description

The CDCLVP111 clock driver distributes one differential clock pair of LVPECL input, (CLK0, CLK1) to ten pairs of differential LVPECL clock (Q0, Q9) outputs with minimum skew for clock distribution. The CDCLVP111 can accept two clock sources into an input multiplexer. The CDCLVP111 is specifically designed for driving 50- $\Omega$  transmission lines. When an output pin is not used, leaving it open is recommended to reduce power consumption. If only one of the output pins from a differential pair is used, the other output pin must be identically terminated to 50  $\Omega$ .

The  $V_{BB}$  reference voltage output is used if single-ended input operation is required. In this case, the  $V_{BB}$  pin should be connected to  $\overline{\text{CLK0}}$  and bypassed to GND through a 10-nF capacitor.

However, for high-speed performance up to 3.5 GHz, the differential mode is strongly recommended.

The CDCLVP111 device is characterized for operation from  $-40^{\circ}\text{C}$  to  $85^{\circ}\text{C}$ .

#### Device Information<sup>(1)</sup>

PART NUMBER	PACKAGE	BODY SIZE (NOM)
CDCLVP111	VQFN (32)	5.00 mm x 5.00 mm
	LQFP (32)	7.00 mm x 7.00 mm

(1) For all available packages, see the orderable addendum at the end of the data sheet.

#### Functional Block Diagram

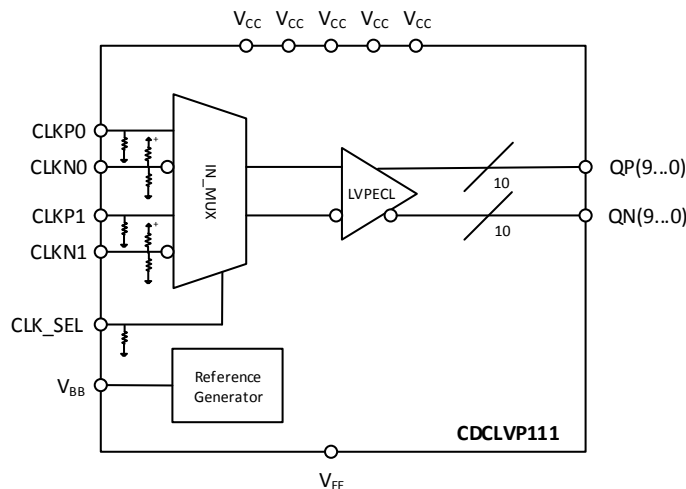



**Changes from Original (January 2009) to Revision A****Page**

- 
- Changed note refernces within the AC ELECTRICAL CHARACTERISTICS table ..... [7](#)
  - Added a Typ value of 0.04ps to the Additive phase jitter in the AC ELECTRICAL CHARACTERISTICS ..... [7](#)
-

## 5 Pin Configuration and Functions

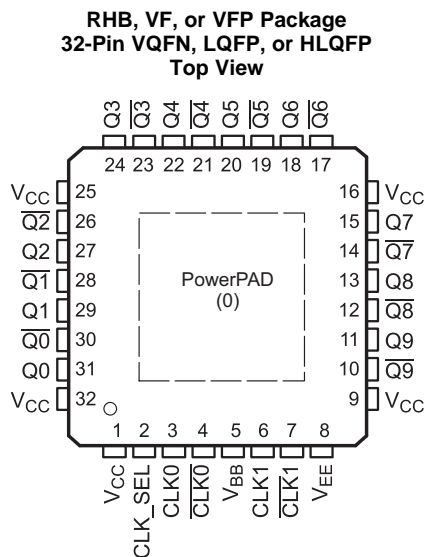

**Pin Functions<sup>(1)</sup>**

PIN		TYPE	DESCRIPTION
NAME	NO.		
CLK_SEL	2	Input	Clock select. Used to select between CLK0 and CLK1 input pairs. LVTTTL/LVCMOS functionality compatible.
CLK0, $\overline{\text{CLK0}}$	3	Input	Differential LVECL/LVPECL input pair
	4		
CLK1, $\overline{\text{CLK1}}$	6	Input	Differential LVECL/LVPECL input pair
	7		
Q [9:0]	11	Output	LVECL/LVPECL clock outputs, these outputs provide low-skew copies of CLKn.
	13		
	15		
	18		
	20		
	22		
	24		
	27		
$\overline{\text{Q}}$ [9:0]	29	Output	LVECL/LVPECL complementary clock outputs, these outputs provide copies of $\overline{\text{CLKn}}$ .
	31		
	10		
	12		
	14		
	17		
	19		
	21		
V <sub>BB</sub>	5	—	Reference voltage output for single-ended input operation

(1) CLKn, CLK\_SEL pull-down resistor = 75 k $\Omega$ ;  $\overline{\text{CLKn}}$  pull-up resistor = 37.5 k $\Omega$ ;  $\overline{\text{CLKn}}$  pull-down resistor = 50 k $\Omega$ .

**Pin Functions<sup>(1)</sup> (continued)**

PIN		TYPE	DESCRIPTION
NAME	NO.		
V <sub>CC</sub>	1	Power	Supply voltage
	9		
	16		
	25		
	32		
V <sub>EE</sub>	8	Ground	Device ground or negative supply voltage in ECL mode
PowerPAD™	0	Ground	The PowerPAD of the QFN32 is thermally connected to the die to improve the heat transfer out of the package. The pad of the QFN32 with PowerPAD must be connected to V <sub>EE</sub> .

## 6 Specifications

### 6.1 Absolute Maximum Ratings

over operating free-air temperature range (unless otherwise noted)<sup>(1)</sup>

	MIN	MAX	UNIT
V <sub>CC</sub> Supply voltage (Relative to V <sub>EE</sub> )	-0.3	4.6	V
V <sub>I</sub> Input voltage	-0.3	V <sub>CC</sub> + 0.5	V
V <sub>O</sub> Output voltage	-0.3	V <sub>CC</sub> + 0.5	V
I <sub>IN</sub> Input current		±20	mA
V <sub>EE</sub> Negative supply voltage (Relative to V <sub>CC</sub> )	-4.6	0.3	V
I <sub>BB</sub> Sink/source current	-1	1	mA
I <sub>O</sub> DC output current		-50	mA
T <sub>J</sub> Maximum operating junction temperature		125	°C
T <sub>stg</sub> Storage temperature	-65	150	°C

(1) Stresses beyond those listed under *Absolute Maximum Ratings* may cause permanent damage to the device. These are stress ratings only, which do not imply functional operation of the device at these or any other conditions beyond those indicated under *Recommended Operating Conditions*. Exposure to absolute-maximum-rated conditions for extended periods may affect device reliability.

### 6.2 ESD Ratings

	VALUE	UNIT
V <sub>(ESD)</sub> Electrostatic discharge	Human body model (HBM), per ANSI/ESDA/JEDEC JS-001 <sup>(1)</sup>	3000
	Charged-device model (CDM), per JEDEC specification JESD22-C101 <sup>(2)</sup>	1500

(1) JEDEC document JEP155 states that 500-V HBM allows safe manufacturing with a standard ESD control process.

(2) JEDEC document JEP157 states that 250-V CDM allows safe manufacturing with a standard ESD control process.

### 6.3 Recommended Operating Conditions

	MIN	NOM	MAX	UNIT
V <sub>CC</sub> Supply voltage (relative to V <sub>EE</sub> )	2.375	2.5/3.3	3.8	V
T <sub>A</sub> Operating free-air temperature	-40		85	°C/W
T <sub>J</sub> Operating junction temperature			110	°C

## 6.4 Thermal Information

THERMAL METRIC <sup>(1)</sup>		CDCLVP111		UNIT
		RHB (VQFN)	VF (LQFP)	
		32 PINS		
R <sub>θJA</sub>	Junction-to-ambient thermal resistance	45.2	85.1	°C/W
R <sub>θJC(top)</sub>	Junction-to-case (top) thermal resistance	37.5	23.2	°C/W
R <sub>θJB</sub>	Junction-to-board thermal resistance	17.9	49.4	°C/W
ψ <sub>JT</sub>	Junction-to-top characterization parameter	1.5	0.9	°C/W
ψ <sub>JB</sub>	Junction-to-board characterization parameter	17.9	48.7	°C/W
R <sub>θJC(bot)</sub>	Junction-to-case (bottom) thermal resistance	9.7	—	°C/W

(1) For more information about traditional and new thermal metrics, see the *Semiconductor and IC Package Thermal Metrics* application report, [SPRA953](#).

## 6.5 DC Electrical Characteristics, LVECL

V<sub>supply</sub>: V<sub>CC</sub> = 0 V, V<sub>EE</sub> = –2.375 V to –3.8 V over operating free-air temperature range (unless otherwise noted)

PARAMETER	TEST CONDITIONS	MIN	TYP	MAX	UNIT	
I <sub>EE</sub>	Supply internal current Absolute value of current	–40°C, 25°C, 85°C	40	85	mA	
I <sub>CC</sub>	Output and internal supply current All outputs terminated 50 Ω to V <sub>CC</sub> – 2 V	–40°C		354	mA	
		25°C		380		
		85°C		405		
I <sub>IN</sub>	Input current Includes pullup/pulldown resistors, V <sub>IH</sub> = V <sub>CC</sub> , V <sub>IL</sub> = V <sub>CC</sub> – 2 V	–40°C, 25°C, 85°C	–150	150	μA	
V <sub>BB</sub>	Internally generated bias voltage For V <sub>EE</sub> = –3 to –3.8 V, I <sub>BB</sub> = –0.2 mA V <sub>EE</sub> = –2.375 to –2.75 V, I <sub>BB</sub> = –0.2 mA	–40°C, 25°C, 85°C	–1.45	–1.3	–1.15	V
		–40°C, 25°C, 85°C	–1.4	–1.25	–1.1	
V <sub>IH</sub>	High-level input voltage (CLK_SEL)	–40°C, 25°C, 85°C	–1.165	–0.88	V	
V <sub>IL</sub>	Low-level input voltage (CLK_SEL)	–40°C, 25°C, 85°C	–1.81	–1.475	V	
V <sub>ID</sub>	Input amplitude (CLK <sub>n</sub> , $\overline{\text{CLK}}_n$ ) Difference of input, see <sup>(1)</sup>  V <sub>IH</sub> – V <sub>IL</sub>	–40°C, 25°C, 85°C	0.5	1.3	V	
V <sub>CM</sub>	Common-mode voltage (CLK <sub>n</sub> , $\overline{\text{CLK}}_n$ ) DC offset relative to V <sub>EE</sub>	–40°C, 25°C, 85°C	V <sub>EE</sub> + 1	–0.3	V	
V <sub>OH</sub>	High-level output voltage I <sub>OH</sub> = –21 mA	–40°C	–1.26	–0.85	V	
		25°C	–1.2	–0.85		
		85°C	–1.15	–0.85		
V <sub>OL</sub>	Low-level output voltage I <sub>OL</sub> = –5 mA	–40°C	–1.85	–1.5	V	
		25°C	–1.85	–1.45		
		85°C	–1.85	–1.4		
V <sub>OD</sub>	Differential output voltage swing Terminated with 50 Ω to V <sub>CC</sub> – 2 V, see <a href="#">Figure 5</a>	–40°C, 25°C, 85°C	600		mV	

(1) V<sub>ID</sub> minimum and maximum is required to maintain ac specifications, actual device function tolerates a minimum V<sub>ID</sub> of 100 mV.

## 6.6 DC Electrical Characteristics, LVPECL

V<sub>supply</sub>: V<sub>CC</sub> = 2.375 V to 3.8 V, V<sub>EE</sub> = 0 V over operating free-air temperature range (unless otherwise noted)

PARAMETER	TEST CONDITIONS	MIN	TYP	MAX	UNIT			
I <sub>EE</sub>	Supply internal current	Absolute value of current		-40°C, 25°C, 85°C	40	85	mA	
I <sub>CC</sub>	Output and internal supply current	All outputs terminated 50 Ω to V <sub>CC</sub> - 2 V		-40°C		354	mA	
				25°C		380		
				85°C		405		
I <sub>IN</sub>	Input current	Includes pullup/pulldown resistors V <sub>IH</sub> =V <sub>CC</sub> , V <sub>IL</sub> =V <sub>CC</sub> -2V		-40°C, 25°C, 85°C	-150	150	μA	
V <sub>BB</sub>	Internally generated bias voltage	V <sub>CC</sub> = 3 to 3.8 V, I <sub>BB</sub> = -0.2 mA		-40°C, 25°C, 85°C	V <sub>CC</sub> - 1.45	V <sub>CC</sub> - 1.3	V <sub>CC</sub> - 1.15	V
		V <sub>CC</sub> = 2.375 to 2.75 V, I <sub>BB</sub> = -0.2 mA		-40°C, 25°C, 85°C	V <sub>CC</sub> - 1.4	V <sub>CC</sub> - 1.25	V <sub>CC</sub> - 1.1	
V <sub>IH</sub>	High-level input voltage (CLK_SEL)			-40°C, 25°C, 85°C	V <sub>CC</sub> - 1.165	V <sub>CC</sub> - 0.88	V	
V <sub>IL</sub>	Low-level input voltage (CLK_SEL)			-40°C, 25°C, 85°C	V <sub>CC</sub> - 1.81	V <sub>CC</sub> - 1.475	V	
V <sub>ID</sub>	Input amplitude (CLK <sub>n</sub> , CLK <sub>n</sub> )	Difference of input, see <sup>(1)</sup> ,  V <sub>IH</sub> - V <sub>IL</sub>		-40°C, 25°C, 85°C	0.5	1.3	V	
V <sub>CM</sub>	Common-mode voltage (CLK <sub>n</sub> , CLK <sub>n</sub> )	DC offset relative to V <sub>EE</sub>		-40°C, 25°C, 85°C	1	V <sub>CC</sub> - 0.3	V	
V <sub>OH</sub>	High-level output voltage	I <sub>OH</sub> = -21 mA		-40°C	V <sub>CC</sub> - 1.26	V <sub>CC</sub> - 0.85	V	
				25°C	V <sub>CC</sub> - 1.2	V <sub>CC</sub> - 0.85		
				85°C	V <sub>CC</sub> - 1.15	V <sub>CC</sub> - 0.85		
V <sub>OL</sub>	Low-level output voltage	I <sub>OL</sub> = -5 mA		-40°C	V <sub>CC</sub> - 1.85	V <sub>CC</sub> - 1.5	V	
				25°C	V <sub>CC</sub> - 1.85	V <sub>CC</sub> - 1.45		
				85°C	V <sub>CC</sub> - 1.85	V <sub>CC</sub> - 1.4		
V <sub>OD</sub>	Differential output voltage swing	Terminated with 50 Ω to V <sub>CC</sub> - 2 V, see <a href="#">Figure 5</a>		-40°C, 25°C, 85°C	600		mV	

(1) V<sub>ID</sub> minimum and maximum is required to maintain ac specifications, actual device function tolerates a minimum V<sub>ID</sub> of 100 mV.

## 6.7 AC Electrical Characteristics

V<sub>supply</sub>: V<sub>CC</sub> = 2.375 V to 3.8 V, V<sub>EE</sub> = 0 V or LVECL/LVPECL input V<sub>CC</sub> = 0 V, V<sub>EE</sub> = -2.375 V to -3.8 V over operating free-air temperature range (unless otherwise noted)

PARAMETER	TEST CONDITIONS	MIN	TYP	MAX	UNIT	
t <sub>pd</sub>	Differential propagation delay CLK <sub>n</sub> , CLK <sub>n</sub> to all Q0, Q0... Q9, Q9	See Note D in <a href="#">Figure 2</a>		200	350	ps
t <sub>sk(o)</sub>	Output-to-output skew	See Note A in <a href="#">Figure 2</a>		15	30	ps
t <sub>sk(pp)</sub>	Part-to-part skew	See Note B in <a href="#">Figure 2</a>			70	ps
t <sub>aj</sub>	Additive phase jitter	Integration bandwidth of 20 kHz to 20 MHz, f <sub>out</sub> = 125 MHz at 25°C		0.04	< 0.8	ps
f <sub>(max)</sub>	Maximum frequency	Functional up to 3.5 GHz			3500	MHz
t <sub>r</sub> /t <sub>f</sub>	Output rise and fall time (20%, 80%)	See Note D in <a href="#">Figure 2</a>		90	200	ps

## 6.8 Typical Characteristics

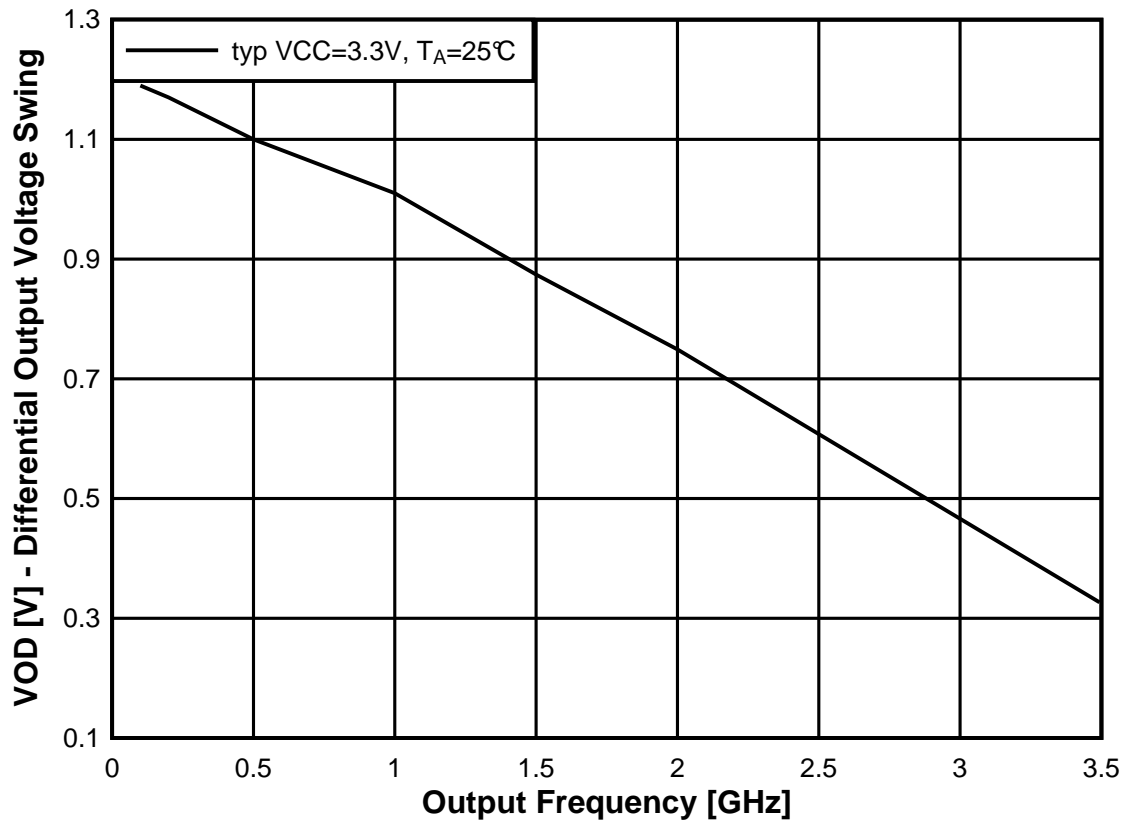
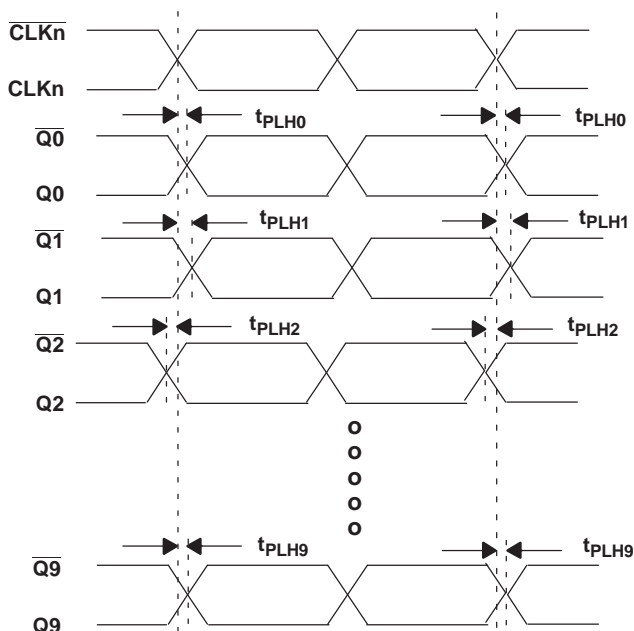

Figure 1. LVPECL Input Using CLK0 Pair,  $V_{CM} = 1\text{ V}$ ,  $V_{ID} = 0.5\text{ V}$



## 7 Parameter Measurement Information

### 7.1 Test Configurations



- Output skew is calculated as the greater of: The difference between the fastest and the slowest  $t_{PLHn}$  ( $n = 0, 1, \dots, 9$ ) or the difference between the fastest and the slowest  $t_{PHLn}$  ( $n = 0, 1, \dots, 9$ ).
- Part-to-part skew, is calculated as the greater of: The difference between the fastest and the slowest  $t_{PLHn}$  ( $n = 0, 1, \dots, 9$ ) across multiple devices or the difference between the fastest and the slowest  $t_{PHLn}$  ( $n = 0, 1, \dots, 9$ ) across multiple devices.
- Typical value measured at ambient when clock input is 155.52 MHz for an integration bandwidth of 20 kHz to 5 MHz.
- Input conditions:  $V_{CM} = 1\text{ V}$ ,  $V_{ID} = 0.5\text{ V}$  and  $F_{IN} = 1\text{ GHz}$ .

**Figure 2. Waveform for Calculating Both Output and Part-to-Part Skew**

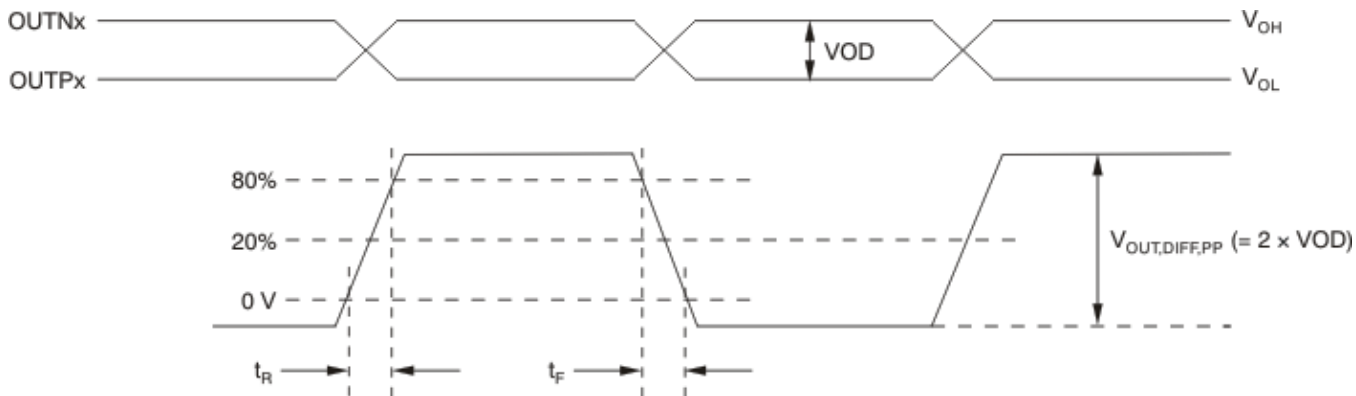

**Figure 3. Output Voltage and Rise and Fall Time**

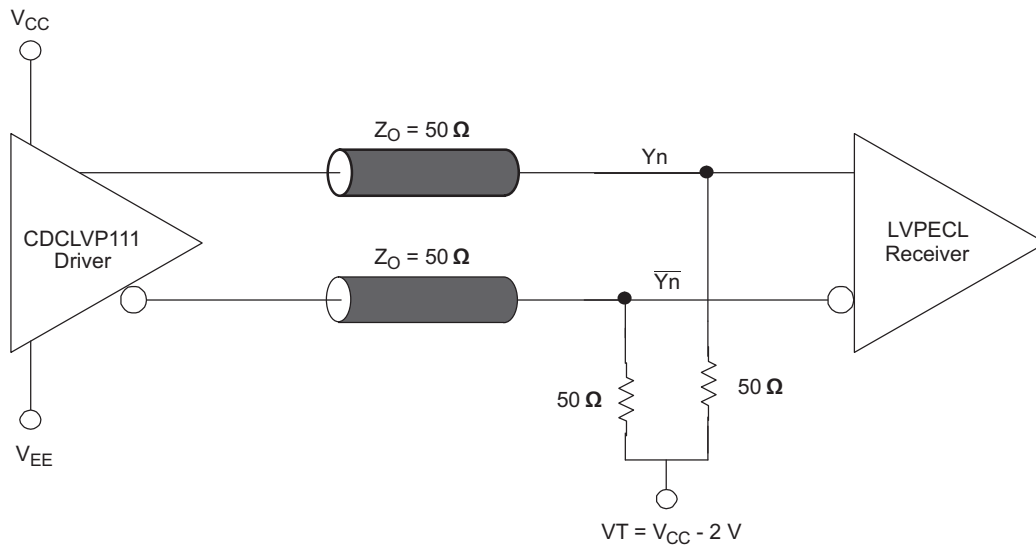
**Test Configurations (continued)**

**Figure 4. Typical Termination for Output Driver (See the Interfacing Between LVPECL, LVDS, and CML Application Note, [SCAA056](#))**

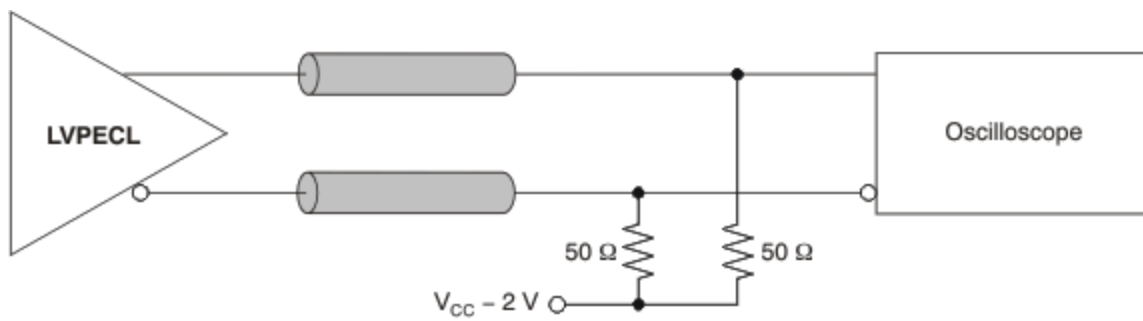

**Figure 5. LVPECL Output DC Configuration During Device Test**

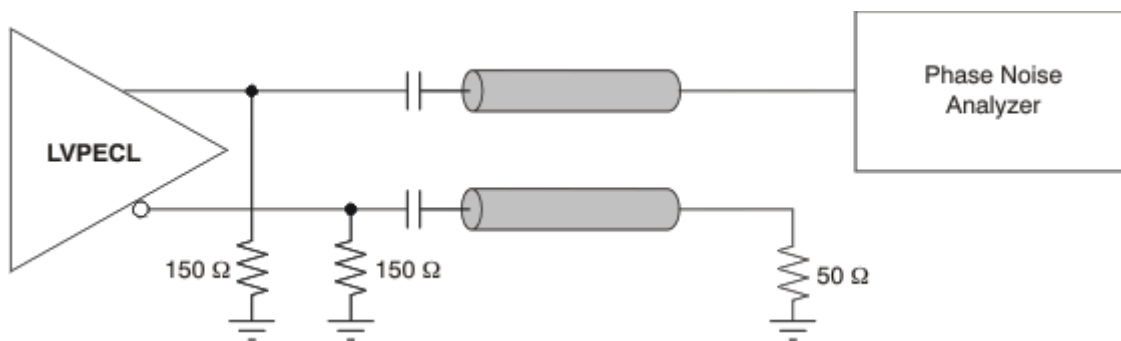

**Figure 6. LVPECL Output AC Configuration During Device Test**

## 8 Detailed Description

### 8.1 Overview

The CDCLVP111 is an open emitter for LVPECL outputs. Therefore, proper biasing and termination are required to ensure correct operation of the device and to minimize signal integrity. The proper termination for LVPECL outputs is a  $50\ \Omega$  to  $(V_{CC} - 2)\text{ V}$ , but this DC voltage is not readily available on PCB. Therefore, a Thevenin equivalent circuit is worked out for the LVPECL termination in both direct-coupled (DC) and AC-coupled configurations. These configurations are shown in Figure 8 (a and b) for  $V_{CC} = 2.5\text{ V}$  and Figure 9 (a and b) for  $V_{CC} = 3.3\text{ V}$ , respectively. TI recommends to place all resistive components close to either the driver end or the receiver end. If the supply voltage for the driver and receiver is different, AC coupling is required.

### 8.2 Functional Block Diagram

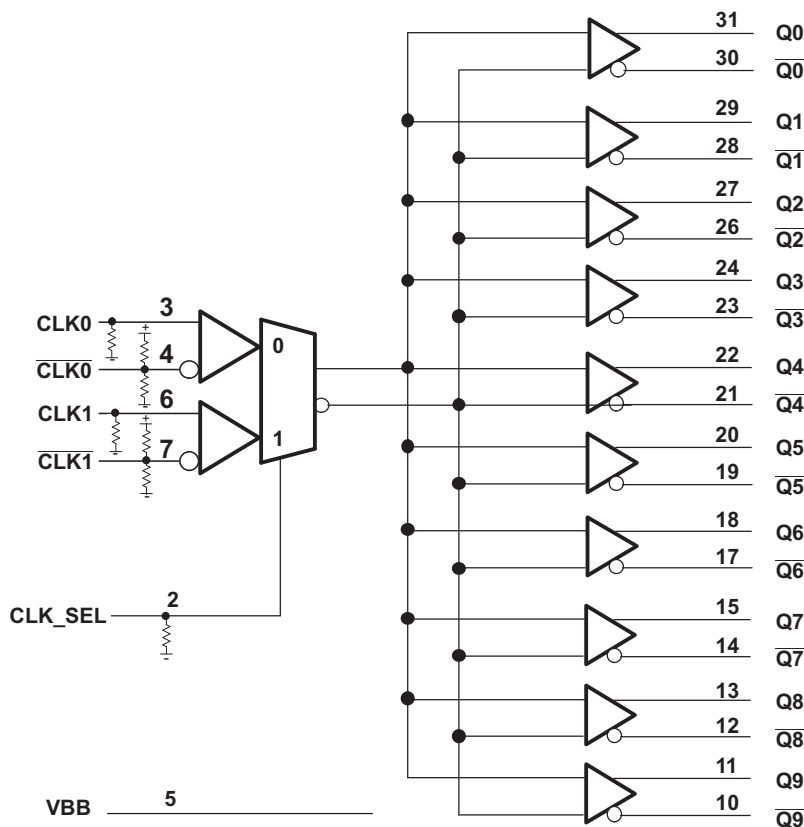

### 8.3 Feature Description

The CDCLVP111 is a low-additive jitter universal to LVPECL fan out buffer with 2 selectable inputs. The small package, low-output skew, and low-additive jitter make for a flexible device in demanding applications.

## 8.4 Device Functional Modes

Select Input Terminal By CLK\_SEL Pin

**Table 1. Function Table**

CLK_SEL	ACTIVE CLOCK INPUT
0	CLK0, $\overline{\text{CLK0}}$
1	CLK1, $\overline{\text{CLK1}}$

The two inputs of the CDCLVP111 are internally mixed together and can be selected through the control pin. Unused inputs and outputs can be left floating to reduce overall component cost. Both AC and DC coupling schemes can be used with the CDCLVP111 to provide greater system flexibility.

## 9 Applications and Implementation

### NOTE

Information in the following applications sections is not part of the TI component specification, and TI does not warrant its accuracy or completeness. TI's customers are responsible for determining suitability of components for their purposes. Customers should validate and test their design implementation to confirm system functionality.

### 9.1 Application Information

The CDCLVP111 is a low-additive jitter LVPECL fanout buffer that can generate 5 copies of 2 selectable LVDS, CML or SSTL inputs. The CDCLVP111 can accept reference clock frequencies up to 3.5 GHz while providing low-output skew.

### 9.2 Typical Application

#### 9.2.1 Fanout Buffer for Line Card Application

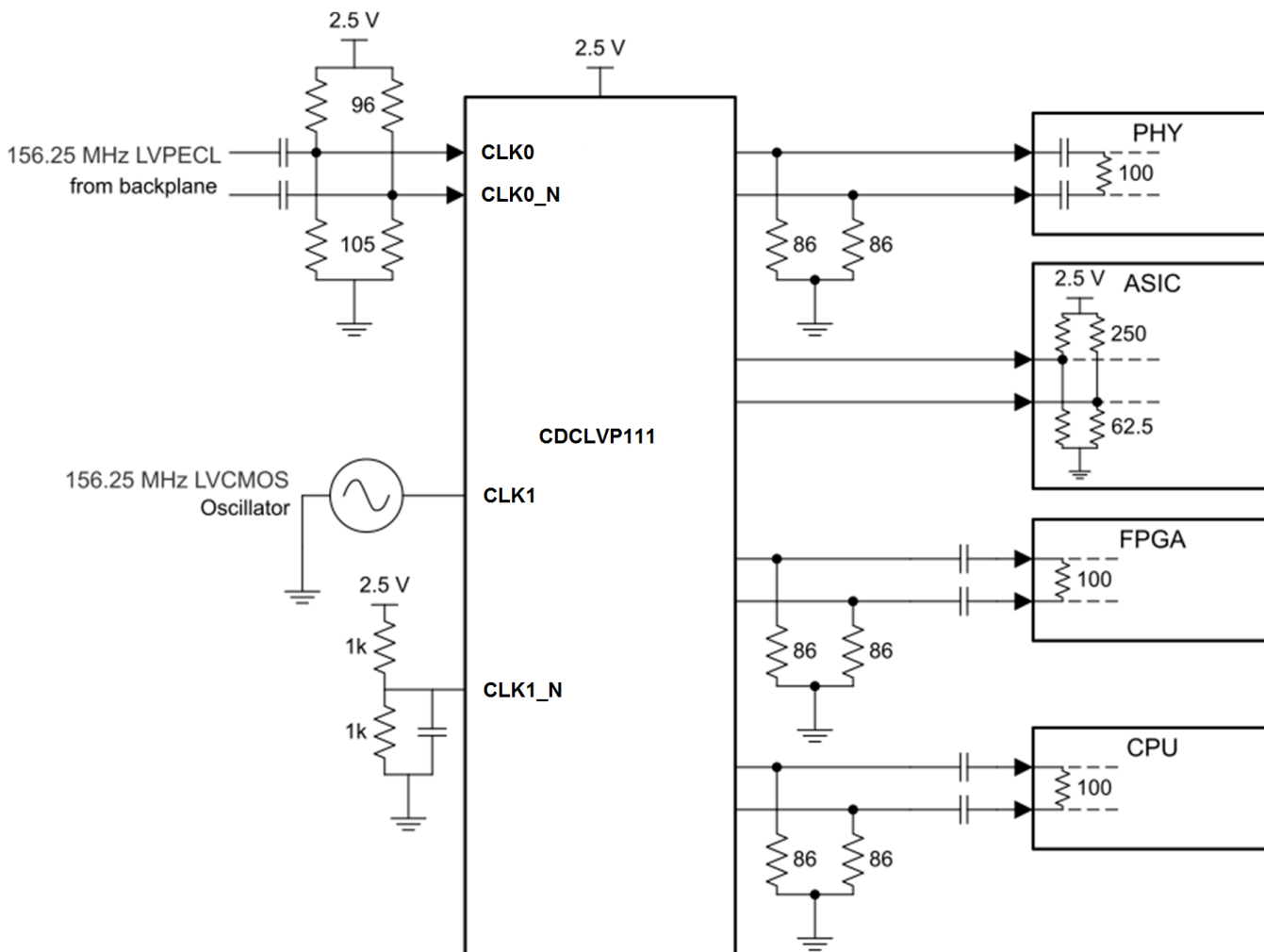

Figure 7. CDCLVP111 Block Diagram

## Typical Application (continued)

### 9.2.1.1 Design Requirements

The CDCLVP111 shown in Figure 7 is configured to be able to select 2 inputs, a 156.25-MHz LVPECL clock from the backplane, or a secondary 156.25-MHz LVCMOS 2.5-V oscillator. Either signal can be then fanned out to desired devices, as shown.

The configuration example is driving 4 LVPECL receivers in a line card application with the following properties:

- The PHY device has internal AC coupling and appropriate termination and biasing. The CDCLVP111 will need to be provided with 86-Ω emitter resistors near the driver for proper operation.
- The ASIC is capable of DC coupling with a 2.5-V LVPECL driver such as the CDCLVP111. This ASIC features internal termination so no additional components are needed.
- The FPGA requires external AC coupling but has internal termination. Again, 86-Ω emitter resistors are placed near the CDCLVP111 and a 0.1-μF are placed to provide AC coupling. Similarly, the CPU is internally terminated and requires external AC coupling capacitors.

### 9.2.1.2 Detailed Design Procedure

Unused outputs can be left floating.

In this example, the PHY, ASIC, and FPGA/CPU require different schemes. Power-supply filtering and bypassing is critical for low-noise applications.

See Figure 18 for recommended filtering techniques.

#### 9.2.1.2.1 LVPECL Output Termination

Refer to Figure 8 for output termination schemes depending on the receiver application.

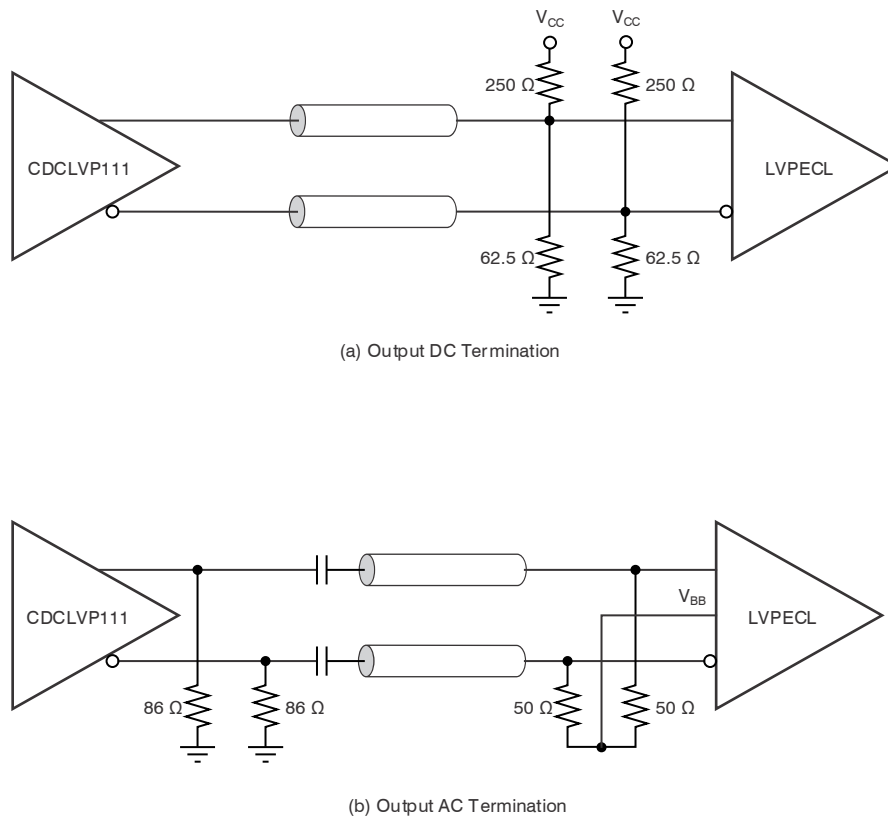

Figure 8. LVPECL Output DC and AC Termination for  $V_{CC} = 2.5\text{ V}$

Typical Application (continued)

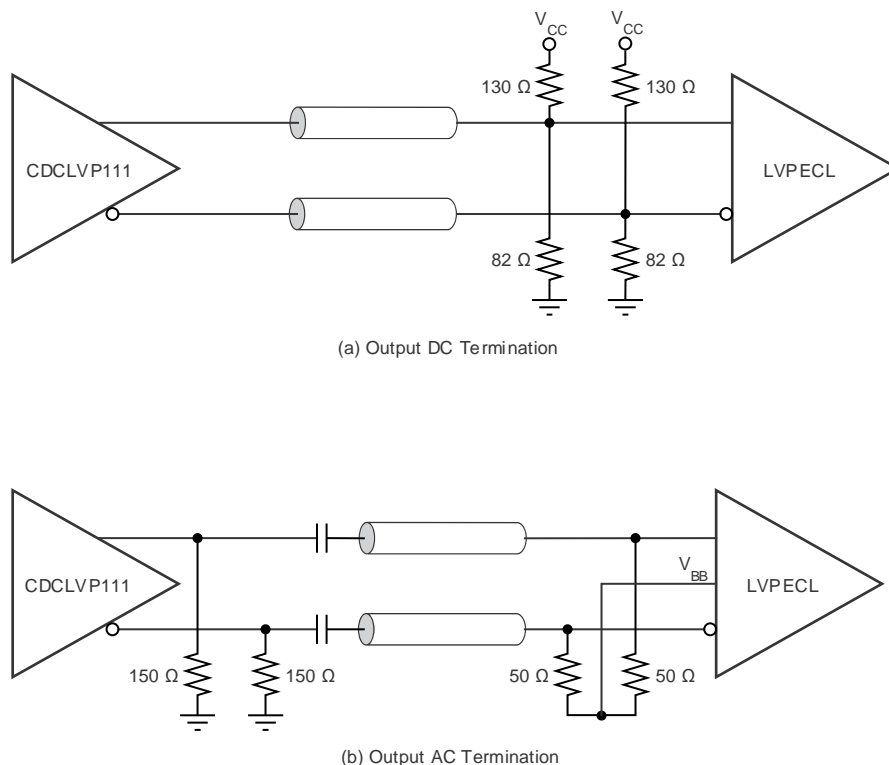

Figure 9. LVPECL Output DC and AC Termination for  $V_{CC} = 3.3\text{ V}$

9.2.1.2.2 Input Termination

The CDCLVP111 inputs can be interfaced with LVPECL, LVDS, or LVCMOS drivers. Figure 10 illustrates how to DC couple an LVCMOS input to the CDCLVP111. The series resistance ( $R_S$ ) should be placed close to the LVCMOS driver; the value is calculated as the difference between the transmission line impedance and the driver output impedance.

Refer to Figure 10 for proper input terminations, dependent on single ended or differential inputs.

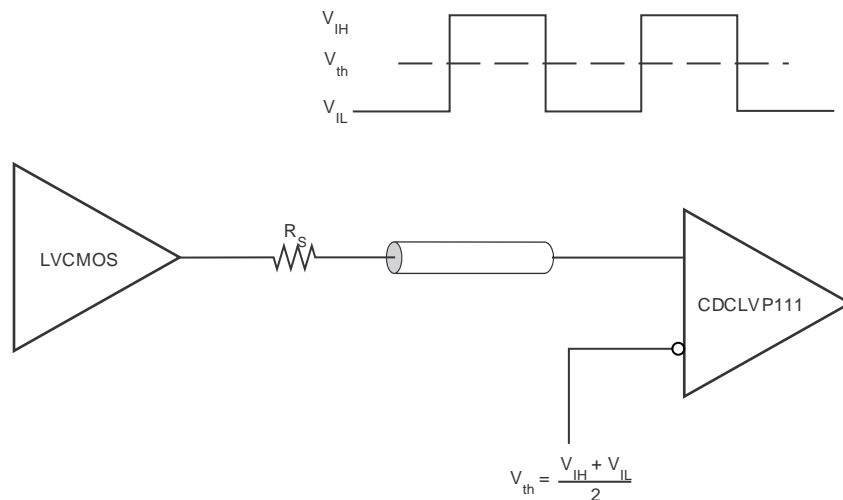
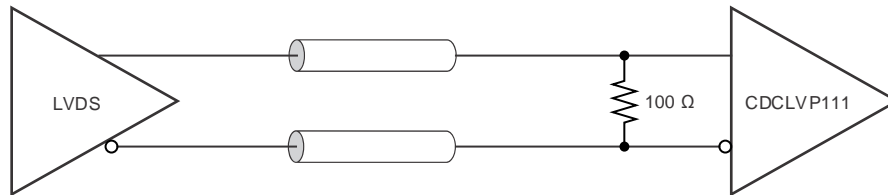

Figure 10. DC-Coupled LVCMOS Input to CDCLVP111

**Typical Application (continued)**

Figure 11 shows how to DC couple LVDS inputs to the CDCLVP111. Figure 12 and Figure 13 describe the method of DC coupling LVPECL inputs to the CDCLVP111 for  $V_{CC} = 2.5\text{ V}$  and  $V_{CC} = 3.3\text{ V}$ , respectively.



**Figure 11. DC-Coupled LVDS Inputs to CDCLVP111**

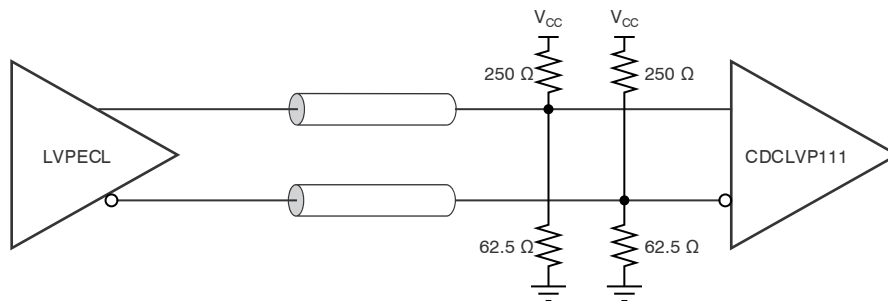

**Figure 12. DC-Coupled LVPECL Inputs to CDCLVP111 ( $V_{CC} = 2.5\text{ V}$ )**

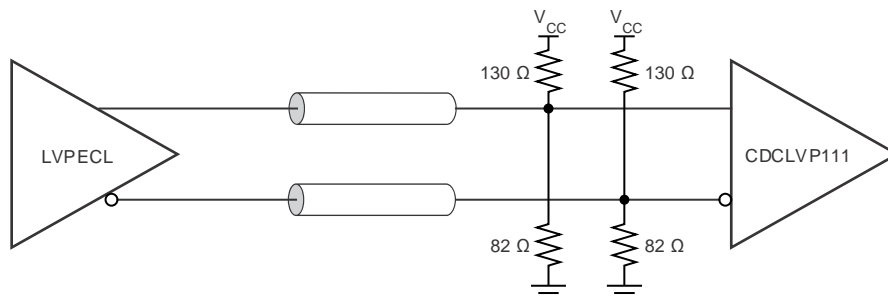

**Figure 13. DC-Coupled LVPECL Inputs to CDCLVP111 ( $V_{CC} = 3.3\text{ V}$ )**



Typical Application (continued)

Figure 14 and Figure 15 show the technique of AC coupling differential inputs to the CDCLVP111 for  $V_{CC} = 2.5\text{ V}$  and  $V_{CC} = 3.3\text{ V}$ , respectively. TI recommends to place all resistive components close to either the driver end or the receiver end. If the supply voltages of the driver and receiver are different, AC coupling is required.

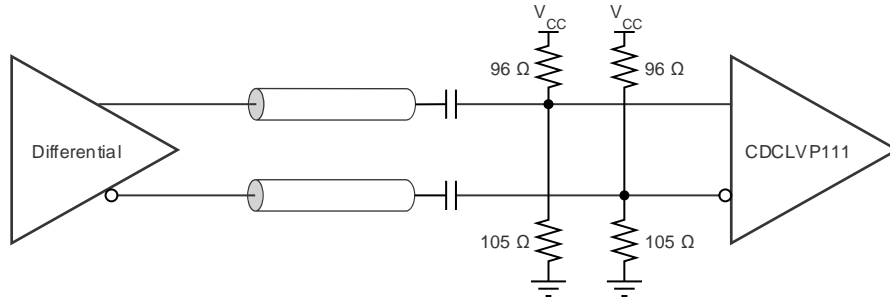

Figure 14. AC-Coupled Differential Inputs to CDCLVP111 ( $V_{CC} = 2.5\text{ V}$ )

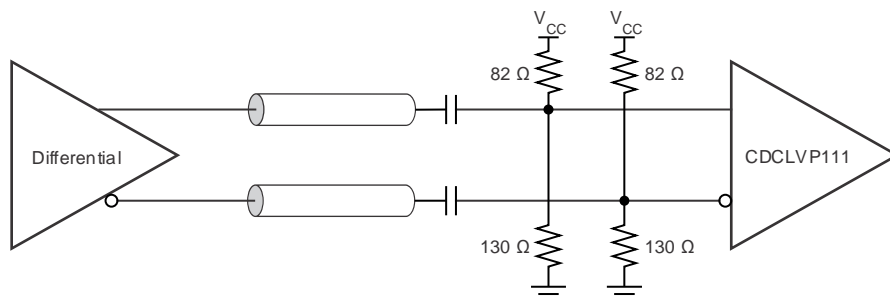
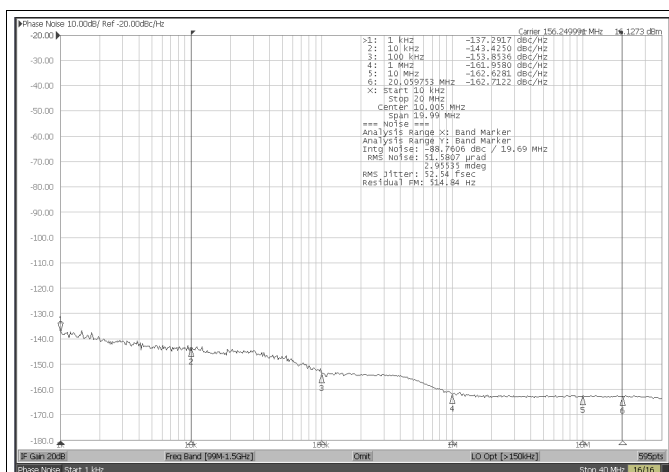

Figure 15. AC-Coupled Differential Inputs to CDCLVP111 ( $V_{CC} = 3.3\text{ V}$ )

9.2.1.3 Application Curves

The CDCLVP111 low-additive noise can be shown in this line card application. The low-noise, 156.25-MHz signal with 53-fs RMS jitter drives the CDCLVP111, resulting in 86-fs RMS when integrated from 10 kHz to 20 MHz. The resultant-additive jitter is a low 68-fs RMS for this configuration.



Reference signal is low noise signal generator

Figure 16. CDCLVP111 Reference Phase Noise 32 fs rms (10 kHz to 20 MHz)

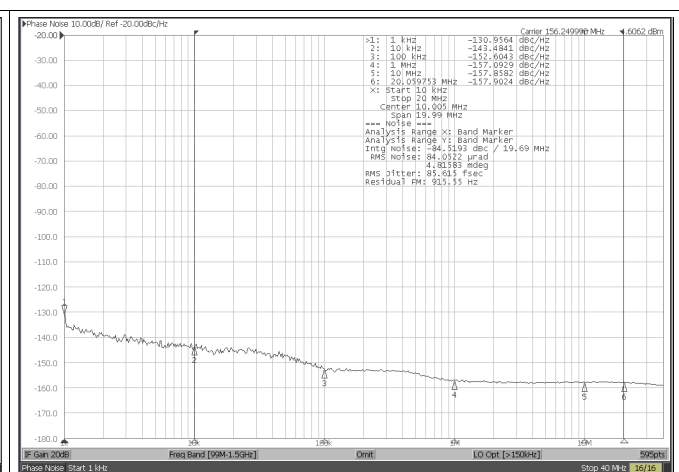

Figure 17. CDCLVP111 Output Phase Noise 57 fs rms (10 kHz to 20 MHz)

## 10 Power Supply Recommendations

### 10.1 Power-Supply Filtering

High-performance clock buffers are sensitive to noise on the power supply, which can dramatically increase the additive jitter of the buffer. Thus, it is essential to reduce noise from the system power supply, especially when jitter and phase noise is very critical to applications.

Filter capacitors are used to eliminate the low-frequency noise from the power supply, where the bypass capacitors provide the very low-impedance path for high-frequency noise and guard the power-supply system against the induced fluctuations. These bypass capacitors also provide instantaneous current surges as required by the device and should have low equivalent series resistance (ESR). To properly use the bypass capacitors, they must be placed very close to the power-supply terminals and laid out with short loops to minimize inductance. TI recommends to add as many high-frequency (for example, 0.1- $\mu\text{F}$ ) bypass capacitors as there are supply terminals in the package. TI recommends, but does not require, to insert a ferrite bead between the board power supply and the chip power supply that isolates the high-frequency switching noises generated by the clock driver; these beads prevent the switching noise from leaking into the board supply. It is imperative to choose an appropriate ferrite bead with very low dc resistance to provide adequate isolation between the board supply and the chip supply, as well as to maintain a voltage at the supply terminals that is greater than the minimum voltage required for proper operation.

Figure 18 illustrates this recommended power-supply decoupling method.

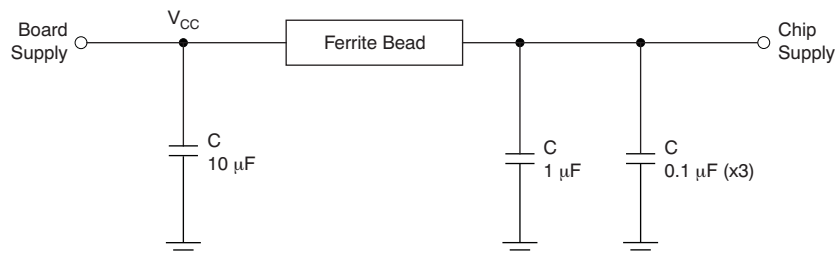

**Figure 18. Power-Supply Decoupling**

## 11 Layout

### 11.1 Layout Guidelines

Power consumption of the CDCLVP111 can be high enough to require attention to thermal management. For reliability and performance reasons, the die temperature should be limited to a maximum of +110°C. That is, as an estimate, ambient temperature ( $T_A$ ) plus device power consumption times  $R_{\theta JA}$  should not exceed +110°C.

The device package has an exposed pad that provides the primary heat removal path to the printed-circuit-board (PCB). To maximize the heat dissipation from the package, a thermal landing pattern including multiple vias to a ground plane must be incorporated into the PCB within the footprint of the package. The exposed pad must be soldered down to ensure adequate heat conduction out of the package. [Figure 19](#) shows a recommended land and via pattern.

### 11.2 Layout Example

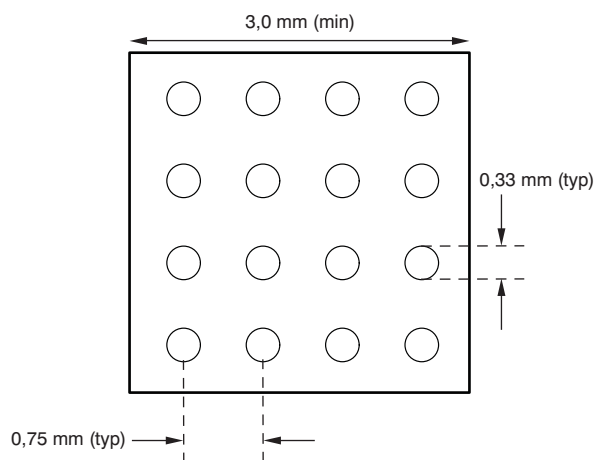

**Figure 19. Recommended PCB Layout**

### 11.3 Thermal Management

Power consumption of the CDCLVP111 can be high enough to require attention to thermal management. For reliability and performance reasons, the die temperature should be limited to a maximum of +110°C. That is, as an estimate, ambient temperature ( $T_A$ ) plus device power consumption times  $R_{\theta JA}$  should not exceed +110°C.

The device package has an exposed pad that provides the primary heat removal path to the printed-circuit-board (PCB). To maximize the heat dissipation from the package, a thermal landing pattern including multiple vias to a ground plane must be incorporated into the PCB within the footprint of the package. The exposed pad must be soldered down to ensure adequate heat conduction out of the package. [Figure 19](#) shows a recommended land and via pattern.

## 12 Device and Documentation Support

### 12.1 Documentation Support

#### 12.1.1 Related Documentation

For related documentation, see the following:

*Interfacing Between LVPECL, LVDS, and CML* Application Note, [SCAA056](#)

### 12.2 Community Resources

The following links connect to TI community resources. Linked contents are provided "AS IS" by the respective contributors. They do not constitute TI specifications and do not necessarily reflect TI's views; see TI's [Terms of Use](#).

**TI E2E™ Online Community** *TI's Engineer-to-Engineer (E2E) Community*. Created to foster collaboration among engineers. At [e2e.ti.com](#), you can ask questions, share knowledge, explore ideas and help solve problems with fellow engineers.

**Design Support** *TI's Design Support* Quickly find helpful E2E forums along with design support tools and contact information for technical support.

### 12.3 Trademarks

PowerPAD, E2E are trademarks of Texas Instruments. All other trademarks are the property of their respective owners.

### 12.4 Electrostatic Discharge Caution



These devices have limited built-in ESD protection. The leads should be shorted together or the device placed in conductive foam during storage or handling to prevent electrostatic damage to the MOS gates.

### 12.5 Glossary

[SLYZ022](#) — *TI Glossary*.

This glossary lists and explains terms, acronyms, and definitions.

## 13 Mechanical, Packaging, and Orderable Information

The following pages include mechanical, packaging, and orderable information. This information is the most current data available for the designated devices. This data is subject to change without notice and revision of this document. For browser-based versions of this data sheet, refer to the left-hand navigation.

## PACKAGING INFORMATION

Orderable Device	Status (1)	Package Type	Package Drawing	Pins	Package Qty	Eco Plan (2)	Lead/Ball Finish (6)	MSL Peak Temp (3)	Op Temp (°C)	Device Marking (4/5)	Samples
CDCLVP111RHBR	ACTIVE	VQFN	RHB	32	3000	Green (RoHS & no Sb/Br)	CU NIPDAU	Level-2-260C-1 YEAR	-40 to 85	LVP111	<a href="#">Samples</a>
CDCLVP111RHBT	ACTIVE	VQFN	RHB	32	250	Green (RoHS & no Sb/Br)	CU NIPDAU	Level-2-260C-1 YEAR	-40 to 85	LVP111	<a href="#">Samples</a>
CDCLVP111VF	ACTIVE	LQFP	VF	32	250	Green (RoHS & no Sb/Br)	CU NIPDAU	Level-1-260C-UNLIM	-40 to 85	CDCLVP111	<a href="#">Samples</a>
CDCLVP111VFR	ACTIVE	LQFP	VF	32	1000	Green (RoHS & no Sb/Br)	CU NIPDAU	Level-1-260C-UNLIM	-40 to 85	CDCLVP111	<a href="#">Samples</a>

(1) The marketing status values are defined as follows:

**ACTIVE:** Product device recommended for new designs.

**LIFEBUY:** TI has announced that the device will be discontinued, and a lifetime-buy period is in effect.

**NRND:** Not recommended for new designs. Device is in production to support existing customers, but TI does not recommend using this part in a new design.

**PREVIEW:** Device has been announced but is not in production. Samples may or may not be available.

**OBSELETE:** TI has discontinued the production of the device.

(2) Eco Plan - The planned eco-friendly classification: Pb-Free (RoHS), Pb-Free (RoHS Exempt), or Green (RoHS & no Sb/Br) - please check <http://www.ti.com/productcontent> for the latest availability information and additional product content details.

**TBD:** The Pb-Free/Green conversion plan has not been defined.

**Pb-Free (RoHS):** TI's terms "Lead-Free" or "Pb-Free" mean semiconductor products that are compatible with the current RoHS requirements for all 6 substances, including the requirement that lead not exceed 0.1% by weight in homogeneous materials. Where designed to be soldered at high temperatures, TI Pb-Free products are suitable for use in specified lead-free processes.

**Pb-Free (RoHS Exempt):** This component has a RoHS exemption for either 1) lead-based flip-chip solder bumps used between the die and package, or 2) lead-based die adhesive used between the die and leadframe. The component is otherwise considered Pb-Free (RoHS compatible) as defined above.

**Green (RoHS & no Sb/Br):** TI defines "Green" to mean Pb-Free (RoHS compatible), and free of Bromine (Br) and Antimony (Sb) based flame retardants (Br or Sb do not exceed 0.1% by weight in homogeneous material)

(3) MSL, Peak Temp. - The Moisture Sensitivity Level rating according to the JEDEC industry standard classifications, and peak solder temperature.

(4) There may be additional marking, which relates to the logo, the lot trace code information, or the environmental category on the device.

(5) Multiple Device Markings will be inside parentheses. Only one Device Marking contained in parentheses and separated by a "~" will appear on a device. If a line is indented then it is a continuation of the previous line and the two combined represent the entire Device Marking for that device.

(6) Lead/Ball Finish - Orderable Devices may have multiple material finish options. Finish options are separated by a vertical ruled line. Lead/Ball Finish values may wrap to two lines if the finish value exceeds the maximum column width.

**Important Information and Disclaimer:** The information provided on this page represents TI's knowledge and belief as of the date that it is provided. TI bases its knowledge and belief on information provided by third parties, and makes no representation or warranty as to the accuracy of such information. Efforts are underway to better integrate information from third parties. TI has taken and continues to take reasonable steps to provide representative and accurate information but may not have conducted destructive testing or chemical analysis on incoming materials and chemicals. TI and TI suppliers consider certain information to be proprietary, and thus CAS numbers and other limited information may not be available for release.

In no event shall TI's liability arising out of such information exceed the total purchase price of the TI part(s) at issue in this document sold by TI to Customer on an annual basis.

**OTHER QUALIFIED VERSIONS OF CDCLVP111 :**

- Enhanced Product: [CDCLVP111-EP](#)

NOTE: Qualified Version Definitions:

- Enhanced Product - Supports Defense, Aerospace and Medical Applications

**TAPE AND REEL INFORMATION**

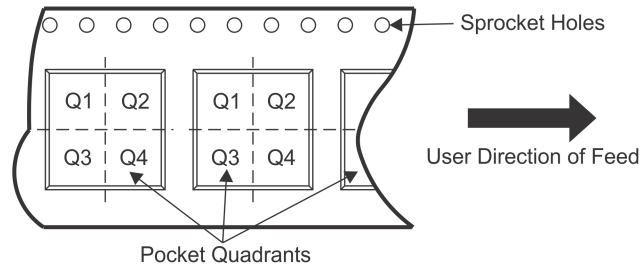
**QUADRANT ASSIGNMENTS FOR PIN 1 ORIENTATION IN TAPE**

\*All dimensions are nominal

Device	Package Type	Package Drawing	Pins	SPQ	Reel Diameter (mm)	Reel Width W1 (mm)	A0 (mm)	B0 (mm)	K0 (mm)	P1 (mm)	W (mm)	Pin1 Quadrant
CDCLVP111RHBR	VQFN	RHB	32	3000	330.0	12.4	5.3	5.3	1.5	8.0	12.0	Q2
CDCLVP111RHBT	VQFN	RHB	32	250	180.0	12.4	5.3	5.3	1.5	8.0	12.0	Q2
CDCLVP111VFR	LQFP	VF	32	1000	330.0	16.4	9.6	9.6	1.9	12.0	16.0	Q2

**TAPE AND REEL BOX DIMENSIONS**

\*All dimensions are nominal

Device	Package Type	Package Drawing	Pins	SPQ	Length (mm)	Width (mm)	Height (mm)
CDCLVP111RHBR	VQFN	RHB	32	3000	336.6	336.6	28.6
CDCLVP111RHBT	VQFN	RHB	32	250	210.0	185.0	35.0
CDCLVP111VFR	LQFP	VF	32	1000	367.0	367.0	38.0



# MECHANICAL DATA

RHB (S-PVQFN-N32)

PLASTIC QUAD FLATPACK NO-LEAD

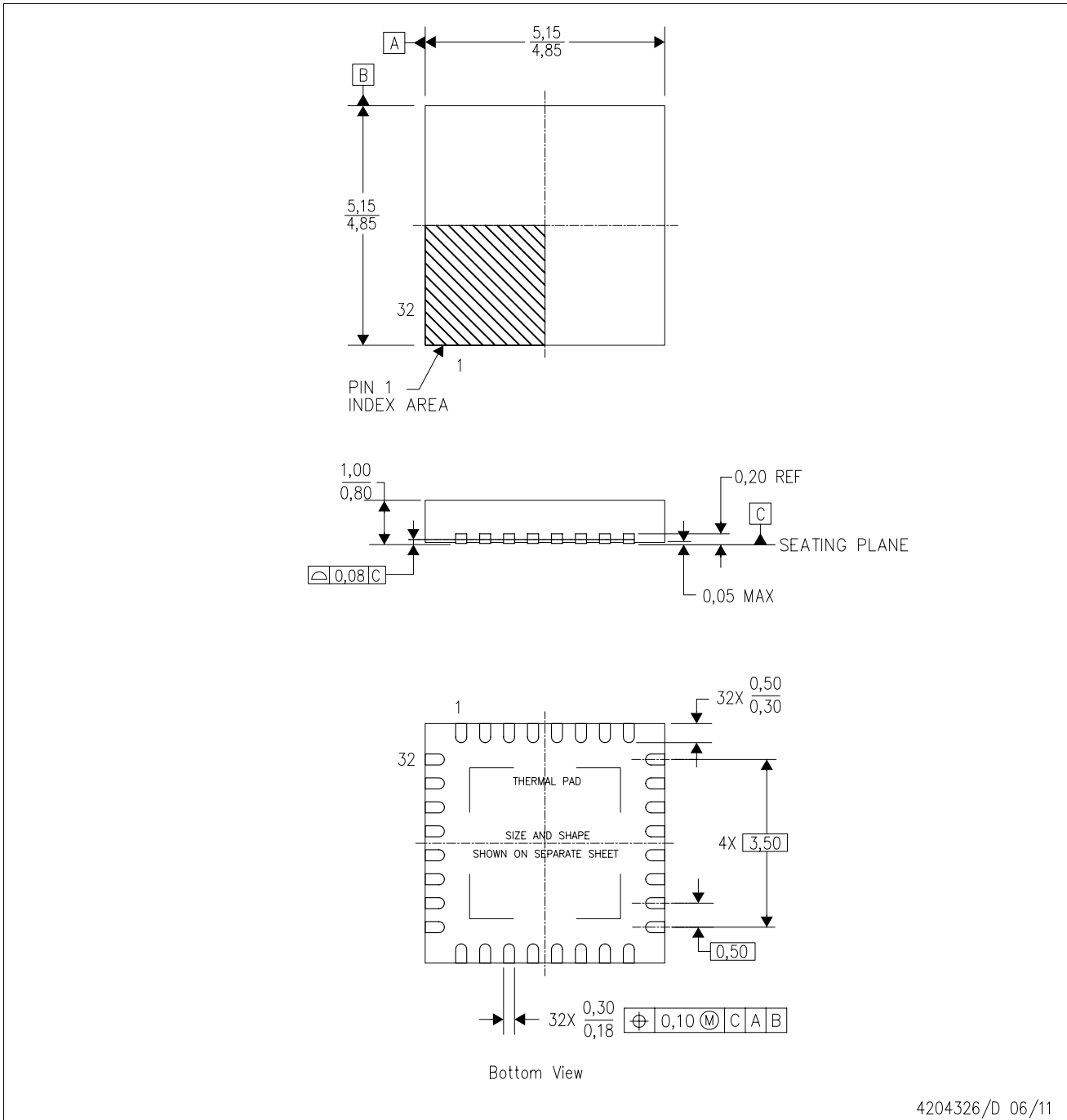

4204326/D 06/11

- NOTES:
- All linear dimensions are in millimeters. Dimensioning and tolerancing per ASME Y14.5M-1994.
  - This drawing is subject to change without notice.
  - QFN (Quad Flatpack No-Lead) Package configuration.
  - The package thermal pad must be soldered to the board for thermal and mechanical performance.
  - See the additional figure in the Product Data Sheet for details regarding the exposed thermal pad features and dimensions.
  - Falls within JEDEC MO-220.

**THERMAL INFORMATION**

This package incorporates an exposed thermal pad that is designed to be attached directly to an external heatsink. The thermal pad must be soldered directly to the printed circuit board (PCB). After soldering, the PCB can be used as a heatsink. In addition, through the use of thermal vias, the thermal pad can be attached directly to the appropriate copper plane shown in the electrical schematic for the device, or alternatively, can be attached to a special heatsink structure designed into the PCB. This design optimizes the heat transfer from the integrated circuit (IC).

For information on the Quad Flatpack No-Lead (QFN) package and its advantages, refer to Application Report, QFN/SON PCB Attachment, Texas Instruments Literature No. SLUA271. This document is available at [www.ti.com](http://www.ti.com).

The exposed thermal pad dimensions for this package are shown in the following illustration.

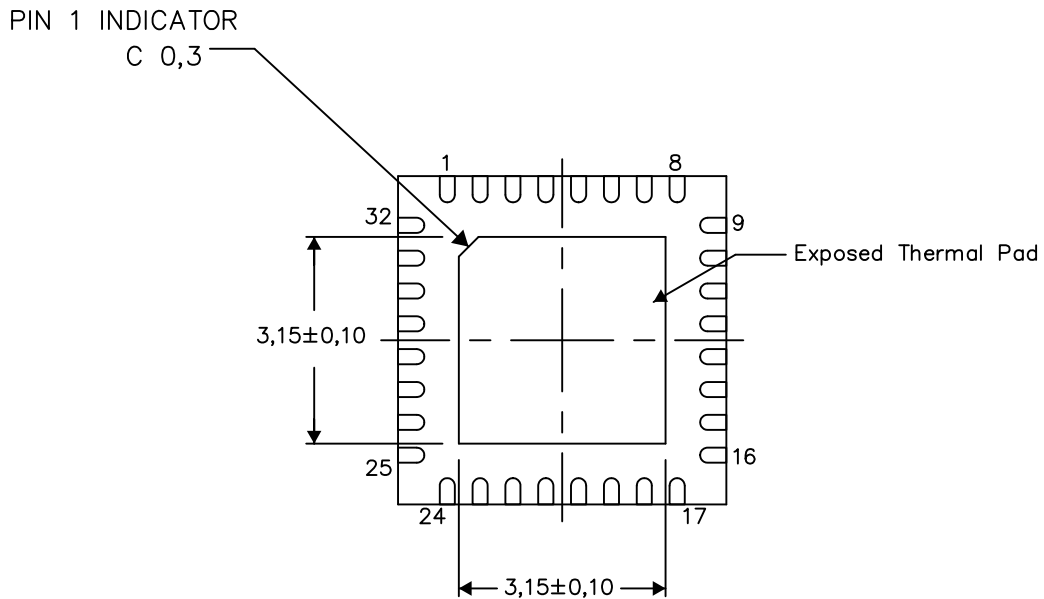

Bottom View

Exposed Thermal Pad Dimensions

4206356-3/AC 05/15

NOTE: A. All linear dimensions are in millimeters

RHB (S-PVQFN-N32)

PLASTIC QUAD FLATPACK NO-LEAD

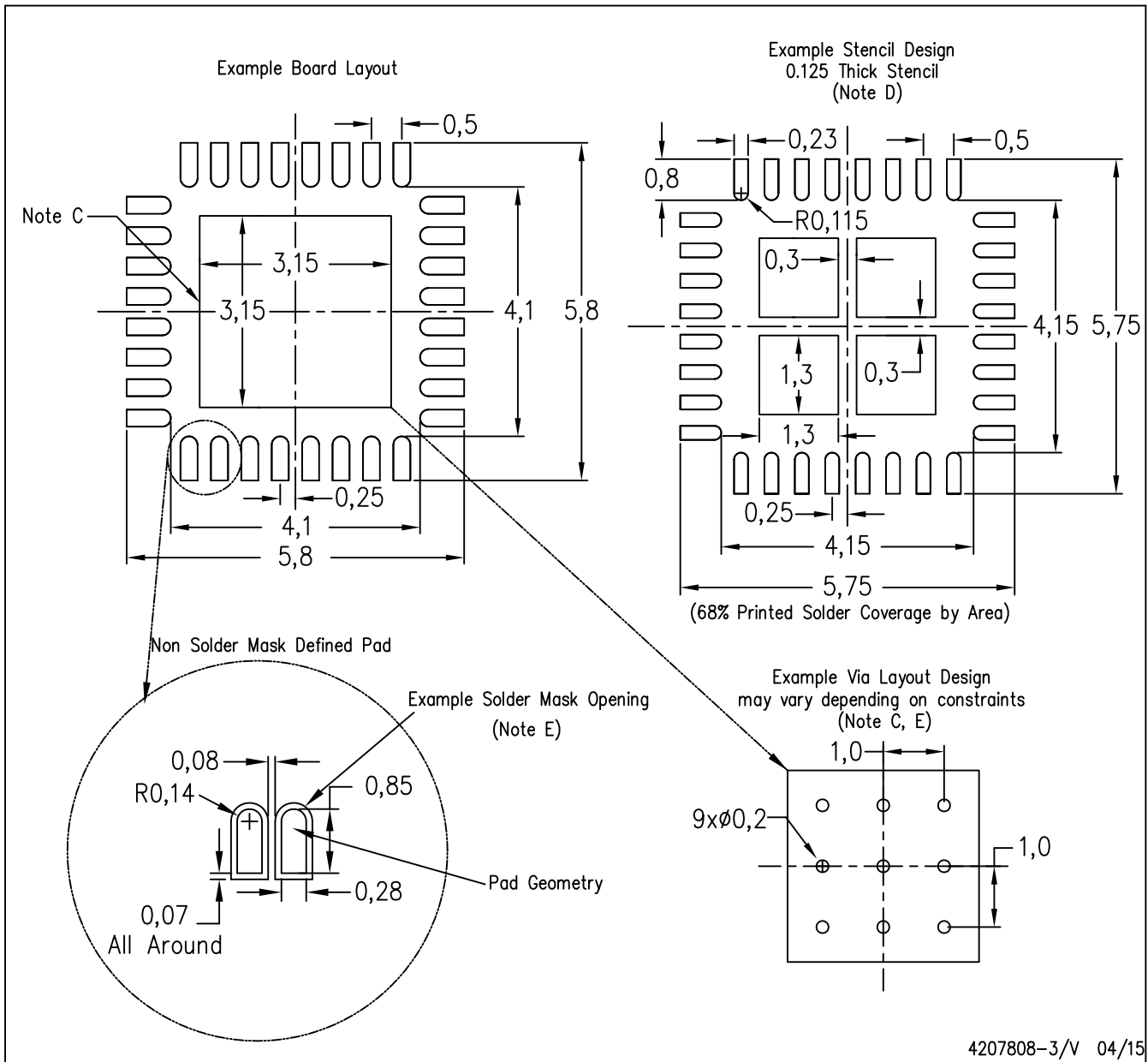

- NOTES:
- All linear dimensions are in millimeters.
  - This drawing is subject to change without notice.
  - This package is designed to be soldered to a thermal pad on the board. Refer to Application Note, Quad Flat-Pack Packages, Texas Instruments Literature No. SLUA271, and also the Product Data Sheets for specific thermal information, via requirements, and recommended board layout. These documents are available at [www.ti.com](http://www.ti.com) <<http://www.ti.com>>.
  - Laser cutting apertures with trapezoidal walls and also rounding corners will offer better paste release. Customers should contact their board assembly site for stencil design recommendations. Refer to IPC 7525 for stencil design considerations.
  - Customers should contact their board fabrication site for recommended solder mask tolerances and via tenting recommendations for any larger diameter vias placed in the thermal pad.

VF (S-PQFP-G32)

PLASTIC QUAD FLATPACK

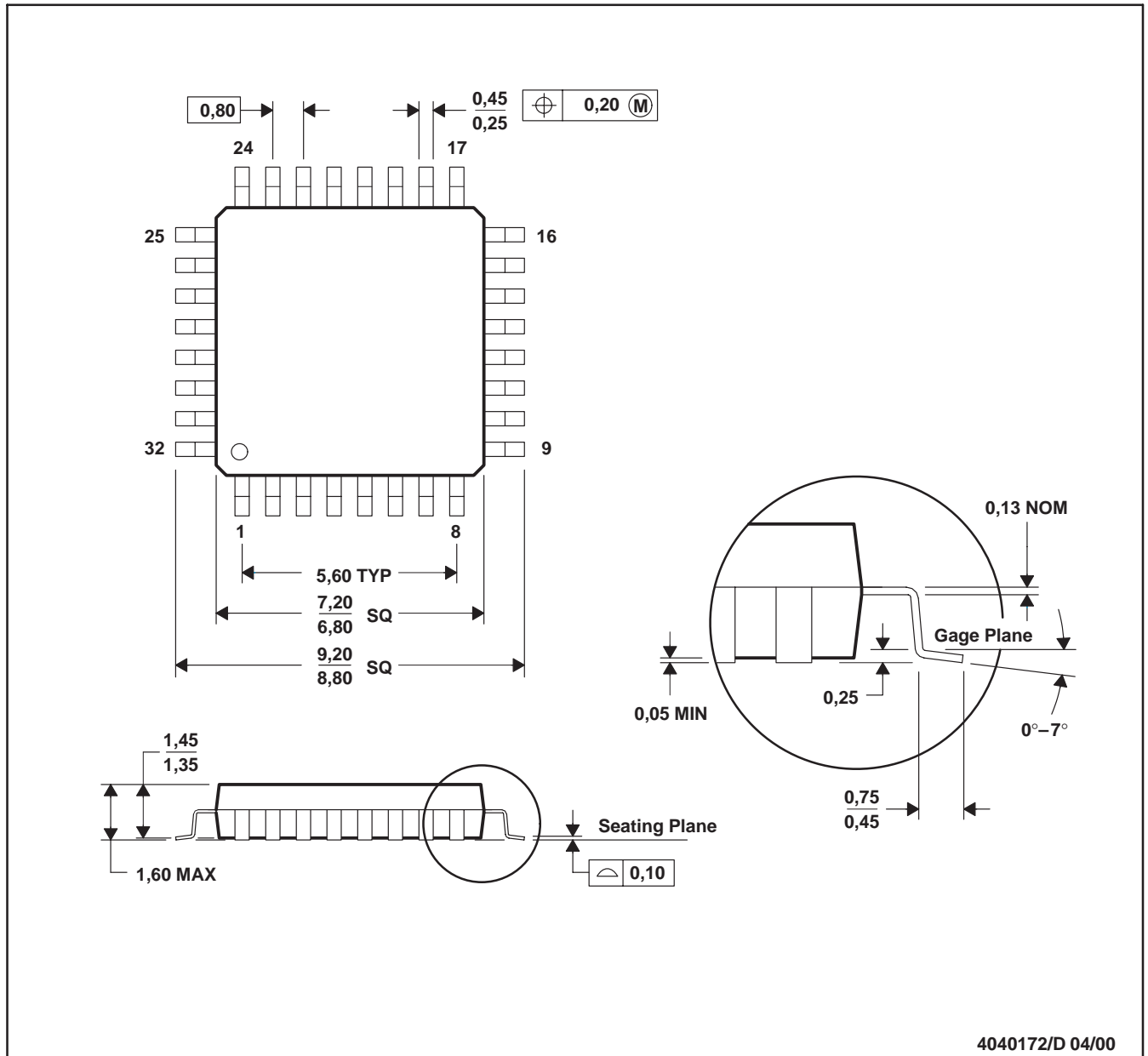

- NOTES: A. All linear dimensions are in millimeters.  
 B. This drawing is subject to change without notice.

## IMPORTANT NOTICE

Texas Instruments Incorporated and its subsidiaries (TI) reserve the right to make corrections, enhancements, improvements and other changes to its semiconductor products and services per JESD46, latest issue, and to discontinue any product or service per JESD48, latest issue. Buyers should obtain the latest relevant information before placing orders and should verify that such information is current and complete. All semiconductor products (also referred to herein as "components") are sold subject to TI's terms and conditions of sale supplied at the time of order acknowledgment.

TI warrants performance of its components to the specifications applicable at the time of sale, in accordance with the warranty in TI's terms and conditions of sale of semiconductor products. Testing and other quality control techniques are used to the extent TI deems necessary to support this warranty. Except where mandated by applicable law, testing of all parameters of each component is not necessarily performed.

TI assumes no liability for applications assistance or the design of Buyers' products. Buyers are responsible for their products and applications using TI components. To minimize the risks associated with Buyers' products and applications, Buyers should provide adequate design and operating safeguards.

TI does not warrant or represent that any license, either express or implied, is granted under any patent right, copyright, mask work right, or other intellectual property right relating to any combination, machine, or process in which TI components or services are used. Information published by TI regarding third-party products or services does not constitute a license to use such products or services or a warranty or endorsement thereof. Use of such information may require a license from a third party under the patents or other intellectual property of the third party, or a license from TI under the patents or other intellectual property of TI.

Reproduction of significant portions of TI information in TI data books or data sheets is permissible only if reproduction is without alteration and is accompanied by all associated warranties, conditions, limitations, and notices. TI is not responsible or liable for such altered documentation. Information of third parties may be subject to additional restrictions.

Resale of TI components or services with statements different from or beyond the parameters stated by TI for that component or service voids all express and any implied warranties for the associated TI component or service and is an unfair and deceptive business practice. TI is not responsible or liable for any such statements.

Buyer acknowledges and agrees that it is solely responsible for compliance with all legal, regulatory and safety-related requirements concerning its products, and any use of TI components in its applications, notwithstanding any applications-related information or support that may be provided by TI. Buyer represents and agrees that it has all the necessary expertise to create and implement safeguards which anticipate dangerous consequences of failures, monitor failures and their consequences, lessen the likelihood of failures that might cause harm and take appropriate remedial actions. Buyer will fully indemnify TI and its representatives against any damages arising out of the use of any TI components in safety-critical applications.

In some cases, TI components may be promoted specifically to facilitate safety-related applications. With such components, TI's goal is to help enable customers to design and create their own end-product solutions that meet applicable functional safety standards and requirements. Nonetheless, such components are subject to these terms.

No TI components are authorized for use in FDA Class III (or similar life-critical medical equipment) unless authorized officers of the parties have executed a special agreement specifically governing such use.

Only those TI components which TI has specifically designated as military grade or "enhanced plastic" are designed and intended for use in military/aerospace applications or environments. Buyer acknowledges and agrees that any military or aerospace use of TI components which have **not** been so designated is solely at the Buyer's risk, and that Buyer is solely responsible for compliance with all legal and regulatory requirements in connection with such use.

TI has specifically designated certain components as meeting ISO/TS16949 requirements, mainly for automotive use. In any case of use of non-designated products, TI will not be responsible for any failure to meet ISO/TS16949.

### Products

Audio	<a href="http://www.ti.com/audio">www.ti.com/audio</a>
Amplifiers	<a href="http://amplifier.ti.com">amplifier.ti.com</a>
Data Converters	<a href="http://dataconverter.ti.com">dataconverter.ti.com</a>
DLP® Products	<a href="http://www.dlp.com">www.dlp.com</a>
DSP	<a href="http://dsp.ti.com">dsp.ti.com</a>
Clocks and Timers	<a href="http://www.ti.com/clocks">www.ti.com/clocks</a>
Interface	<a href="http://interface.ti.com">interface.ti.com</a>
Logic	<a href="http://logic.ti.com">logic.ti.com</a>
Power Mgmt	<a href="http://power.ti.com">power.ti.com</a>
Microcontrollers	<a href="http://microcontroller.ti.com">microcontroller.ti.com</a>
RFID	<a href="http://www.ti-rfid.com">www.ti-rfid.com</a>
OMAP Applications Processors	<a href="http://www.ti.com/omap">www.ti.com/omap</a>
Wireless Connectivity	<a href="http://www.ti.com/wirelessconnectivity">www.ti.com/wirelessconnectivity</a>

### Applications

Automotive and Transportation	<a href="http://www.ti.com/automotive">www.ti.com/automotive</a>
Communications and Telecom	<a href="http://www.ti.com/communications">www.ti.com/communications</a>
Computers and Peripherals	<a href="http://www.ti.com/computers">www.ti.com/computers</a>
Consumer Electronics	<a href="http://www.ti.com/consumer-apps">www.ti.com/consumer-apps</a>
Energy and Lighting	<a href="http://www.ti.com/energy">www.ti.com/energy</a>
Industrial	<a href="http://www.ti.com/industrial">www.ti.com/industrial</a>
Medical	<a href="http://www.ti.com/medical">www.ti.com/medical</a>
Security	<a href="http://www.ti.com/security">www.ti.com/security</a>
Space, Avionics and Defense	<a href="http://www.ti.com/space-avionics-defense">www.ti.com/space-avionics-defense</a>
Video and Imaging	<a href="http://www.ti.com/video">www.ti.com/video</a>

### TI E2E Community

[e2e.ti.com](http://e2e.ti.com)