

2.7V to 5.5V, 12-Bit, Octal DIGITAL-TO-ANALOG CONVERTER in a Wafer Chip-Scale Package—Pb-Free/Green

FEATURES

- Eight, 12-Bit, Voltage Output DACs in One Package
- Pin-Compatible, Pb-Free, RoHS-Compliant Upgrade to the TLV5610IYE
- Programmable Settling Time versus Power Consumption:
 - 1 μ s in Fast Mode
 - 3 μ s in Slow Mode
- Compatible With TMS320™ DSP Family and SPI™ Serial Ports
- Differential and Single-Ended Analog Input/Output
- Separate Software Control for ADC and DAC Power Down
- Monotonic Over Temperature
- Low Power Consumption:
 - 18mW in Slow Mode at 3V
 - 48mW in Fast Mode at 3V
- Power Down Mode
- Buffered, High-Impedance Reference Inputs
- Data Output for Daisy-Chaining

APPLICATIONS

- Digital Servo-Control Loops
- Digital Offset and Gain Adjustment
- Industrial Process Control
- Machine and Motion Control Devices
- Mass Storage Devices

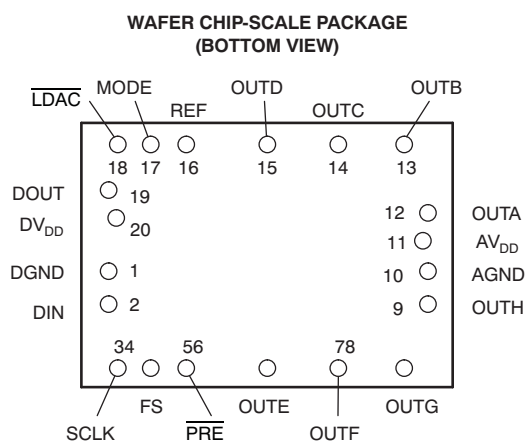

DESCRIPTION

The TLV5610IYZ is the lead-free version of the TLV5610IYE, an eight-channel, 12-bit, voltage output digital-to-analog converter (DAC) with a flexible serial interface. The serial interface allows glueless interface to TMS320 and SPI, QSPI™, and Microwire™ serial ports. It is programmed with a 16-bit serial string containing four control and 12 data bits.

Additional features include a power-down mode, an $\overline{\text{LDAC}}$ input for simultaneous update of all eight DAC outputs, and a data output that can be used to cascade multiple devices.

The resistor string output voltage is buffered by a rail-to-rail output amplifier with a programmable settling time to allow the designer to optimize speed versus power dissipation. The buffered, high-impedance reference input can be connected to the supply voltage.

The TLV5610IYZ is implemented in a CMOS process and is available in a 20-terminal wafer chip-scale package (WCSP). The TLV5610IYZ is characterized for operation from -40°C to $+85^{\circ}\text{C}$ in a wire-bonded small outline (SO) package.



Please be aware that an important notice concerning availability, standard warranty, and use in critical applications of Texas Instruments semiconductor products and disclaimers thereto appears at the end of this data sheet.

TMS320 is a trademark of Texas Instruments, Inc.
 SPI, QSPI are trademarks of Motorola, Inc.
 Microwire is a trademark of National Semiconductor Corp.
 All other trademarks are the property of their respective owners.



This integrated circuit can be damaged by ESD. Texas Instruments recommends that all integrated circuits be handled with appropriate precautions. Failure to observe proper handling and installation procedures can cause damage.

ESD damage can range from subtle performance degradation to complete device failure. Precision integrated circuits may be more susceptible to damage because very small parametric changes could cause the device not to meet its published specifications.

ORDERING INFORMATION

T_A	WCSP-20 PACKAGE⁽¹⁾
–40°C to +85°C	TLV5610IYZ

(1) For the most current package and ordering information, see the Package Option Addendum at the end of this document, or see the TI web site at www.ti.com.

ABSOLUTE MAXIMUM RATINGS

Over operating free-air temperature range (unless otherwise noted)⁽¹⁾

	TLV5610IYZ	UNIT
Supply voltage (AV_{DD} , DV_{DD} to GND)	7	V
Reference input voltage range	– 0.3 to $AV_{DD} + 0.3$	V
Digital input voltage range	– 0.3 to $DV_{DD} + 0.3$	V
Operating free-air temperature range, T_A	–40 to +85	°C

(1) Stresses beyond those listed under *absolute maximum ratings* may cause permanent damage to the device. These are stress ratings only and functional operation of the device at these or any other conditions beyond those indicated under *recommended operating conditions* is not implied. Exposure to absolute-maximum-rated conditions for extended periods may affect device reliability.

RECOMMENDED OPERATING CONDITIONS

		MIN	NOM	MAX	UNIT
Supply voltage, AV_{DD} , DV_{DD}	5V operation	4.5	5	5.5	V
	3V operation	2.7	3	3.3	V
High-level digital input, V_{IH}	$DV_{DD} = 2.7V$ to 5.5V	2			V
Low-level digital input, V_{IL}	$DV_{DD} = 2.7V$ to 5.5V			0.8	V
Reference voltage, V_{REF}	$AV_{DD} = 5V$	GND	4.096	AV_{DD}	V
	$AV_{DD} = 3V$	GND	2.048	AV_{DD}	V
Load resistance, R_L		2			k Ω
Load capacitance, C_L				100	pF
Clock frequency, f_{CLK}				30	MHz
Operating free-air temperature, T_A		–40		+85	°C

ELECTRICAL CHARACTERISTICS

Over operating free-air temperature range (unless otherwise noted)

PARAMETER		TEST CONDITIONS	MIN	TYP	MAX	UNIT
Power Supply						
I _{DD}	Power-supply current	Fast	No load, V _{REF} = 4.096V, all inputs = DV _{DD} or GND	16	21	mA
		Slow		6	8	mA
Power-down supply current				0.1		μA
POR	Power-on threshold			2		V
PSRR	Power-supply rejection ratio	Full-scale; see Note (1)		–60		dB
Static DAC Specifications						
Resolution				12		Bits
INL	Integral nonlinearity	Code 40 to 4095, V _{REF} = 2V, 4V		±2	±6	LSB
DNL	Differential nonlinearity	Code 40 to 4095, V _{REF} = 2V, 4V		±0.5	±1	LSB
E _{ZS}	Zero-scale error (offset error at zero-scale)				±30	mV
E _{ZS} TC	Zero-scale error temperature coefficient			30		μV/°C
E _G	Gain error				±0.6	% Full-Scale V
E _G TC	Gain error temperature coefficient			10		ppm/°C
Output Specifications						
V _O	Voltage output range	R _L = 10kΩ	0		AV _{DD} – 4	V
Output load regulation accuracy		R _L = 2kΩ vs 10kΩ			±0.3	% Full-Scale V
Reference Input						
V _I	Input voltage range		0		AV _{DD}	V
R _I	Input resistance			100		kΩ
C _I	Input capacitance			5		pF
	Reference input bandwidth	Fast	V _{REF} = 0.4V _{PP} + 2.048V _{DC} , input code = 0x800	2.2		MHz
		Slow		1.9		MHz
Reference feedthrough		V _{REF} = 2V _{PP} at 1kHz + 2.048V _{DC} (2)		–84		dB
Digital Inputs						
I _{IH}	High-level digital input current	V _I = DV _{DD}			1	μA
I _{IL}	Low-level digital input current	V _I = 0V	–1			μA
C _I	Input capacitance			8		pF
Digital Outputs						
V _{OH}	High-level digital output voltage	R _L = 10kΩ	2.6			V
V _{OL}	Low-level digital output voltage	R _L = 10kΩ			0.4	V
Output voltage rise time		R _L = 10kΩ, C _L = 20pF, incl. propagation delay		7	20	ns
Analog Output Dynamic Performance						
t _S (FS)	Output settling time(3), full-scale	Fast	R _L = 10kΩ, C _L = 1000pF	1	3	μs
		Slow		3	7	μs
t _S (CC)	Output settling time(4), code to code	Fast	R _L = 10kΩ, C _L = 1000pF	0.5	1	μs
		Slow		1	2	μs
SR	Slew rate(5)	Fast	R _L = 10kΩ, C _L = 1000pF	4	10	V/μs
		Slow		1	3	V/μs
Glitch energy		See Note (6)		4		nV-s
Channel crosstalk		10kHz sine, 4V _{PP}		–90		dB

(1) Power-supply rejection ratio at full-scale is measured by varying AV_{DD} and is given by the following equation:

$$PSRR = 20 \log[(EG(AV_{DDmax}) - EG(AV_{DDmin})) / V_{DDmax}]$$

(2) Reference feedthrough is measured at the DAC output with an input code = 0x000.

(3) Settling time is the time for the output signal to remain within ±0.5 LSB of the final measured value for a digital input code change of 0x80 to 0xFFF and 0xFFF to 0x080, respectively. Assured by design; not production tested.

(4) Settling time is the time for the output signal to remain within ±0.5 LSB of the final measured value for a digital input code change of one count. The max time applies to code changes near zero scale or full-scale. Assured by design; not production tested.

(5) Slew rate determines the time it takes for a change of the DAC output from 10% to 90% full-scale voltage.

(6) Code transition: 0x7FF to 0x800.

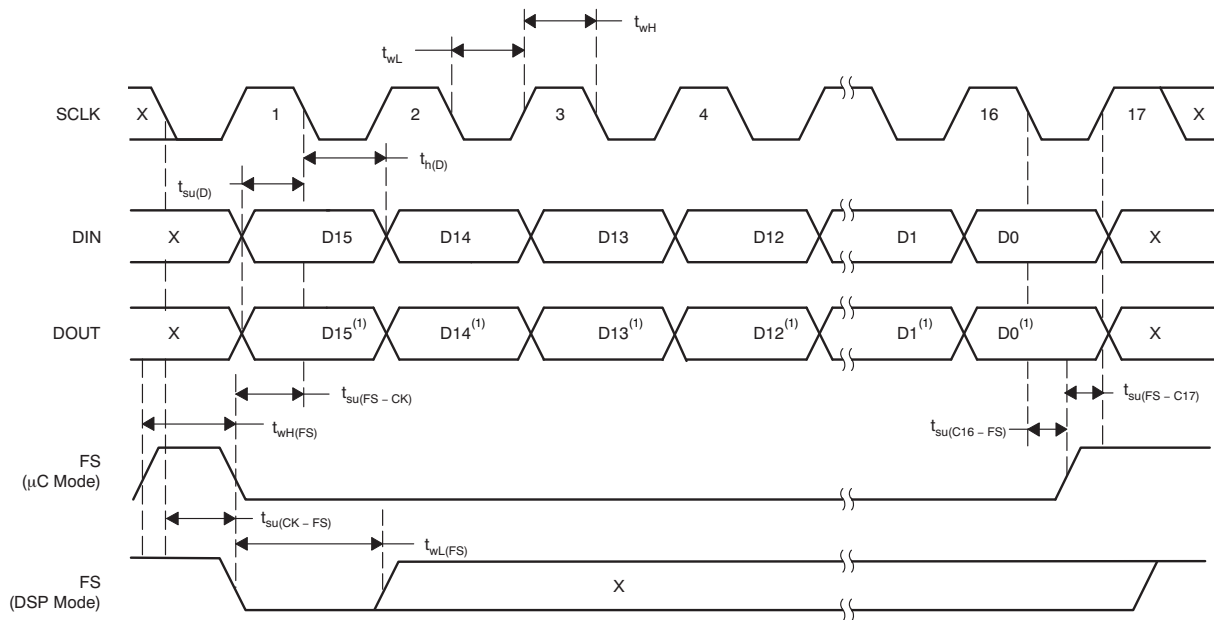

NOTE: (1) Previous input data.

Figure 1. Serial Interface Timing

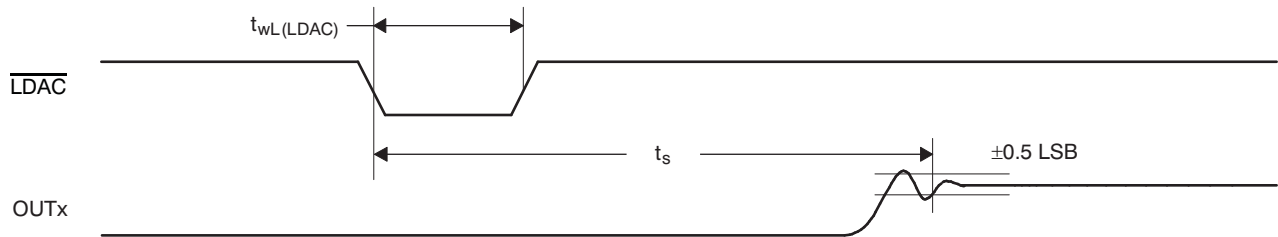
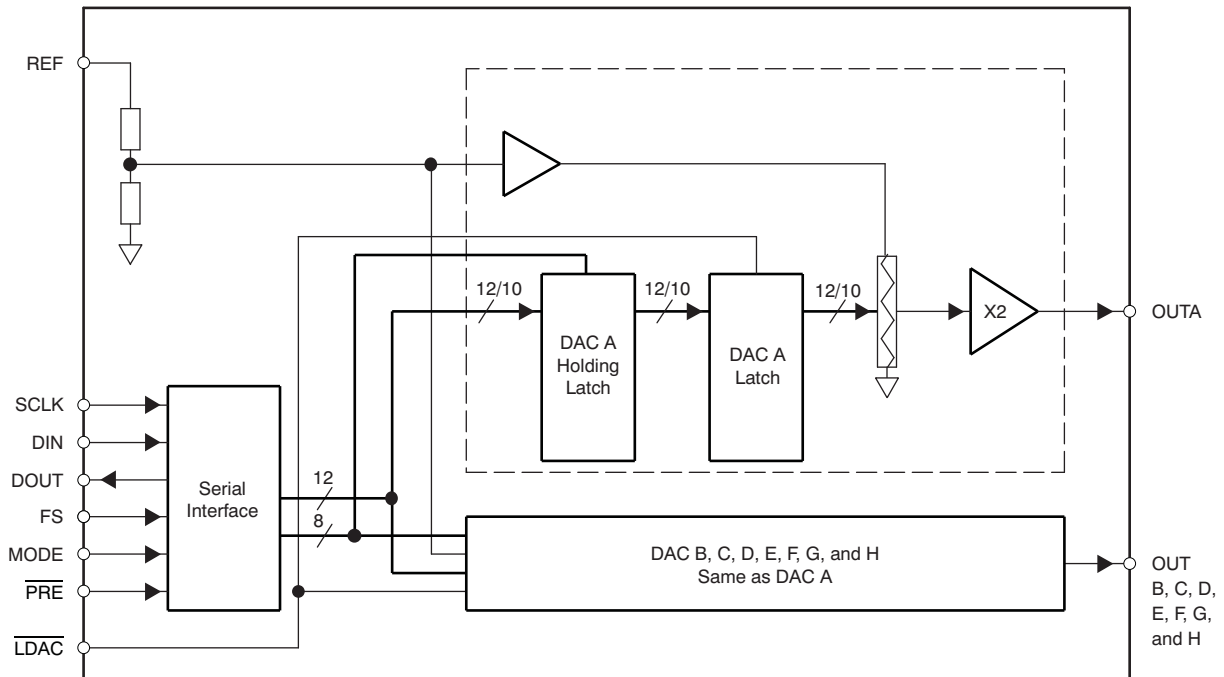

Figure 2. Output Timing

DIGITAL INPUT TIMING REQUIREMENTS

PARAMETER		MIN	TYP	MAX	UNIT
$t_{su}(FS-CK)$	Setup time, FS low before next negative SCLK edge	8			ns
$t_{su}(C16-FS)$	Setup time, 16th negative edge after FS low on which bit D0 is sampled before rising edge of FS. μ C mode only	10			ns
$t_{su}(FS-C17)$	μ C mode, setup time, FS high before 17th positive SCLK.	10			ns
$t_{su}(CK-FS)$	DSP mode, setup time, SLCK low before FS low.	5			ns
$t_{wL}(LDAC)$	LDAC duration low	10			ns
t_{wH}	SCLK pulse duration high	16			ns
t_{wL}	SCLK pulse duration low	16			ns
$t_{su}(D)$	Setup time, data ready before SCLK falling edge	8			ns
$t_{h}(D)$	Hold time, data held valid after SCLK falling edge	5			ns
$t_{wH}(FS)$	FS duration high	10			ns
$t_{wL}(FS)$	FS duration low	10			ns
t_s	Settling time	See Analog Output Dynamic Performance			

Functional Block Diagram



Terminal Functions

TERMINAL		I/O	DESCRIPTION
NAME	NO.		
AGND	10	P	Analog ground
AV _{DD}	11	P	Analog power supply
DGND	1	P	Digital ground
DIN	2	I	Digital serial data input
DOUT	19	O	Digital serial data output
DV _{DD}	20	P	Digital power supply
FS	4	I	Frame sync input
LDAC	18	I	Load DAC. The DAC outputs are only updated if this signal is low. It is an asynchronous input.
MODE	17	I	DSP/μC mode pin. High = μC mode; NC = DSP mode.
PRE	5	I	Preset input
REF	16	I	Voltage reference input
SCLK	3	I	Serial clock input
OUTA–OUTH	12–15, 6–9	O	DAC outputs A, B, C, D, E, F, G and H

TYPICAL CHARACTERISTICS

OUTPUT LOAD REGULATION

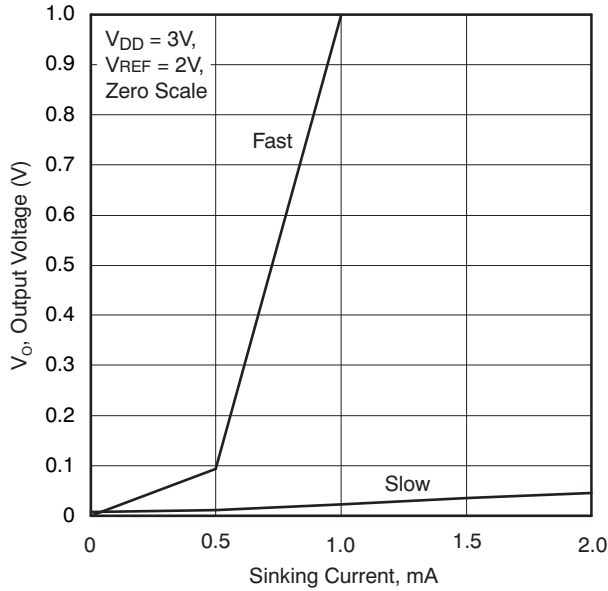

Figure 3.

OUTPUT LOAD REGULATION

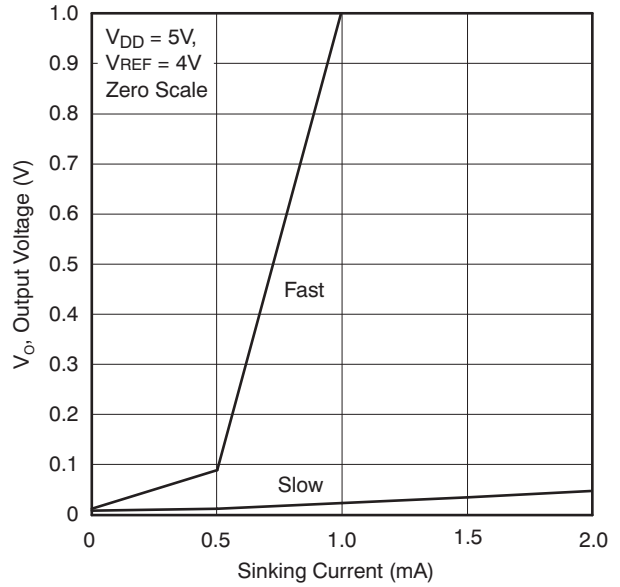

Figure 4.

OUTPUT LOAD REGULATION

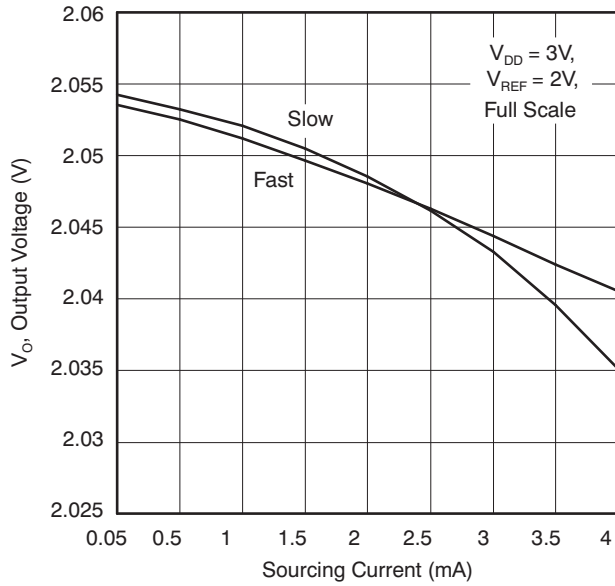

Figure 5.

OUTPUT LOAD REGULATION

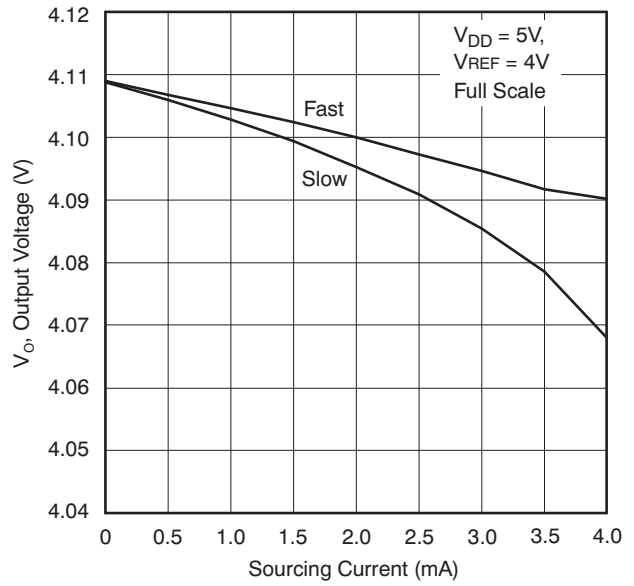

Figure 6.

TYPICAL CHARACTERISTICS (continued)

**INTEGRAL NONLINEARITY
vs CODE**

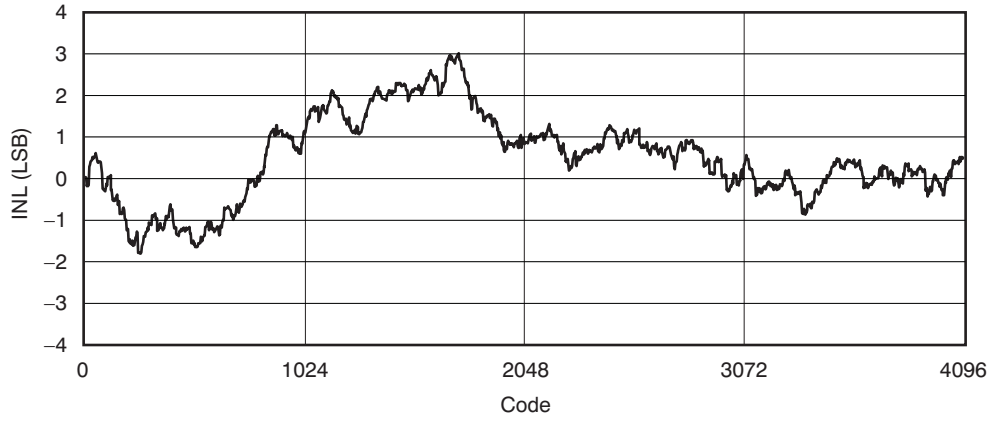

Figure 7.

**DIFFERENTIAL NONLINEARITY
vs CODE**

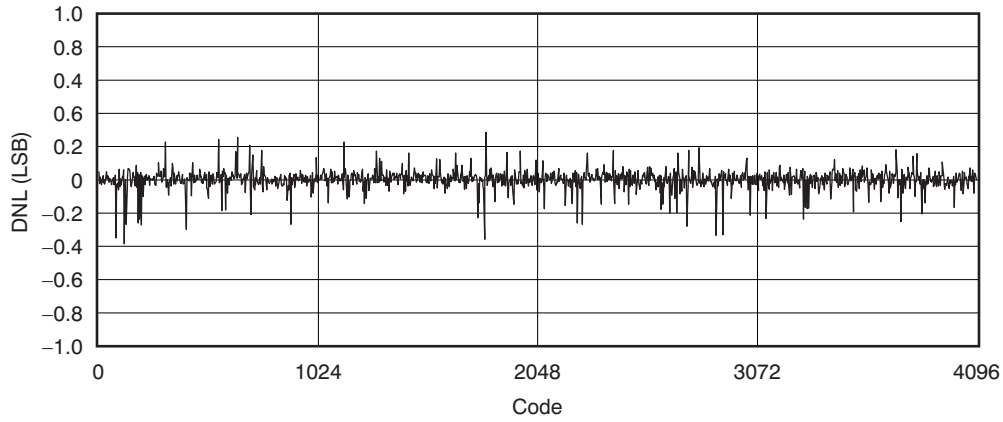

Figure 8.

APPLICATION INFORMATION

GENERAL FUNCTION

The TLV5610IYZ is an eight-channel, 12-bit, single-supply DAC, based on a resistor string architecture. The TLV5610IYZ, a green/PB-free device, is pin-compatible with the TLV5610IYE. The TLV5610IYZ consists of a serial interface, a speed and power-down control logic, a reference input buffer, a resistor string, and a rail-to-rail output buffer.

The output voltage (full-scale determined by external reference) for each channel is given by:

$$REF \frac{CODE}{0x1000} [V] \tag{1}$$

Where:

REF is the reference voltage.

CODE is the digital input value.

The input range is 0x000 to 0xFFFF.

A power on reset initially puts the internal latches to a defined state (all bits zero).

SERIAL INTERFACE

A falling edge of FS starts shifting the data on DIN, starting with the MSB to the internal register on the falling edges of SCLK. After 16 bits have been transferred, the content of the shift register is moved to one of the DAC holding registers, depending on the address bits within the data word. A logic '0' on the \overline{LDAC} pin is required to transfer the content of the DAC holding register to the DAC latch and to update the DAC outputs. \overline{LDAC} is an asynchronous input; it can be held low if a simultaneous update of all eight channels is not needed.

For daisy-chaining, DOUT provides the data sampled on DIN with a delay of 16 clock cycles.

DSP Mode:

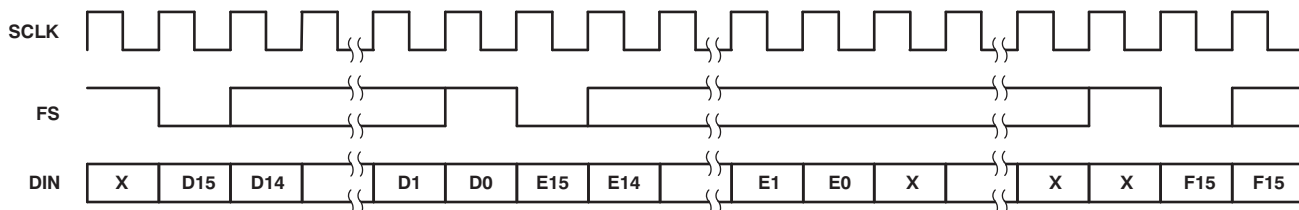

μC Mode:

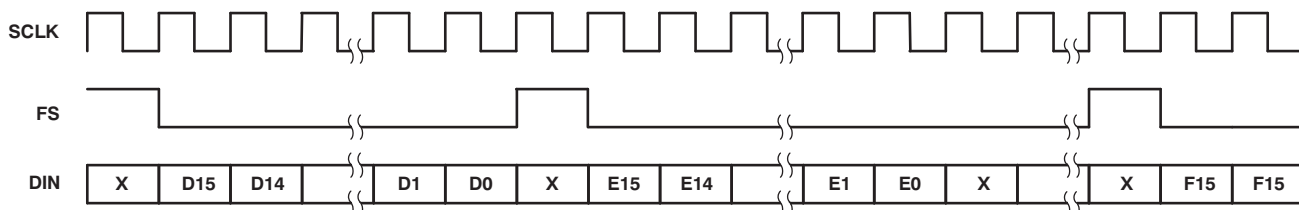

Figure 9. Timing Diagrams

The differences between DSP mode (MODE = NC or 0) and μC (MODE = 1) mode:

- In μC mode, FS must be held low until all 16 data bits have been transferred. If FS is driven high before the 16th falling clock edge, the data transfer is cancelled. The DAC is updated after a rising edge on FS.
- In DSP mode, FS must only stay low for 20ns and can go high before the 16th falling clock edge.

APPLICATION INFORMATION (continued)**SERIAL CLOCK FREQUENCY AND UPDATE RATE**

The maximum serial clock frequency is given by:

$$f_{\text{sclkmax}} = \frac{1}{t_{\text{whmin}} + t_{\text{wlmin}}} = 30\text{MHz} \quad (2)$$

The maximum update rate is given by:

$$f_{\text{updatemax}} = \frac{1}{16(t_{\text{whmin}} + t_{\text{wlmin}})} = 1.95\text{MHz} \quad (3)$$

Note that the maximum update rate is just a theoretical value for the serial interface because the settling time of the DAC must also be considered.

DATA FORMAT

The 16 bit data word consists of two parts:

1. Address bits (D15...D12)
2. Data bits (D11...D0)

Table 1. Data Format⁽¹⁾

D15	D14	D13	D12	D11	D10	D9	D8	D7	D6	D5	D4	D3	D2	D1	D0
A3	A2	A1	A0	Data											

(1) Ax: Address bits. See [Table 2](#).

REGISTER MAP**Table 2. Register Map**

A3	A2	A1	A0	FUNCTION
0	0	0	0	DAC A
0	0	0	1	DAC B
0	0	1	0	DAC C
0	0	1	1	DAC D
0	1	0	0	DAC E
0	1	0	1	DAC F
0	1	1	0	DAC G
0	1	1	1	DAC H
1	0	0	0	CTRL0
1	0	0	1	CTRL1
1	0	1	0	Preset
1	0	1	1	Reserved
1	1	0	0	DAC A and \bar{B}
1	1	0	1	DAC C and \bar{D}
1	1	1	0	DAC E and \bar{F}
1	1	1	1	DAC G and \bar{H}

DAC A-H AND TWO-CHANNEL REGISTERS

Writing to DAC A–H sets the output voltage of channel A–H. It is possible to automatically generate the complement of one channel by writing to one of the four, two-channel registers (DAC A and \bar{B} , etc.).

The TLV5610IYZ decodes all 12 data bits.

PRESET

The outputs of all DAC channels can be driven to a predefined value stored in the preset register by driving the $\overline{\text{PRE}}$ input low. The $\overline{\text{PRE}}$ input is asynchronous to the clock.

CTRL0

Table 3. CTRL0 Bit Register

D11	D10	D9	D8	D7	D6	D5	D4	D3	D2	D1	D0
X	X	X	X	X	X	X	PD	DO	X	X	IM

Bit Definitions:

PD Full Device Power Down.

0 = Normal

1 = Power Down

DO Digital Output Enable.

0 = Disable

1 = Enable

IM Input Mode.

0 = Straight Binary

1 = Twos Complement

X Reserved.

If DOUT is enabled, the data input on DIN is output on DOUT with a 16-cycle delay. This feature makes it possible to daisy-chain multiple DACs on one serial bus.

CTRL1

Table 4. CTRL1 Bit Register

D11	D10	D9	D8	D7	D6	D5	D4	D3	D2	D1	D0
X	X	X	X	X	X	X	PD	DO	X	X	IM

Bit Definitions:

P_{XY} Power Down DAC_{XY}. In power-down mode, the amplifiers of the selected DAC pair within the device are disabled and the total power consumption of the device is significantly reduced. Power-down mode of a specific DAC pair can be selected by setting the P_{XY} bit within the data word to '1'.

0 = Normal

1 = Power Down

S_{XY} DAC_{XY} Speed Mode. There are two settling time modes: fast and slow. Fast mode of a DAC pair is selected by setting S_{XY} to '1', and slow mode is selected by setting S_{XY} to '0'.

0 = Slow

1 = Fast

NOTE: XY refers to DAC pair AB, CD, EF, or GH.

USING THE TLV5610IYZ WAFER CHIP-SCALE PACKAGE (WCSP)

TLV5610 qualifications are done using a wire-bonded small outline (SO) package. The qualifications include: steady state life, thermal shock, ESD, latch-up, biased HAST, autoclave, and characterization. These qualified devices are orderable as TLV5610IDW.

NOTE: The wafer chip-scale package (WCSP) for the TLV5610IYZ uses the same **die** as TLV5610IDW, but is not qualified. WCSP qualification, including board level reliability (BLR), is the responsibility of the customer.

It is recommended that underfill be used for increased reliability. BLR is application-dependent, but may include tests such as: temperature cycling, drop test, key push, bend, vibration, and package shear.

For general guidelines on board assembly of the WCSP, the following documentation provides more details:

- Application Report [NanoStar™ & NanoFree™ 300µm Solder Bump WCSP Application—SBVA017](#)
- [Design Summary WCSP Little Logic—SCET007B](#)

NOTE: The use of underfill is **required** and greatly reduces the risk of thermal mismatch fails.

Underfill is an epoxy/adhesive that may be added during the board assembly process to improve board level/system level reliability. The process is to dispense the epoxy under the dice after die attach reflow. The epoxy adheres to the body of the device and to the printed-circuit board. It reduces stress placed upon the solder joints because of thermal coefficient of expansion (TCE) mismatch between the board and the component. Underfill material is highly filled with silica or other fillers to increase epoxy modulus, reduce creep sensitivity, and decrease material TCE.

NOTE: The recommendation for peak flow temperatures of +250°C to +260°C is based on general empirical results that indicate that this temperature range is needed to facilitate good wetting of the solder bump to the substrate or circuit board pad. Lower peak temperatures may cause nonwets (cold solder joints).

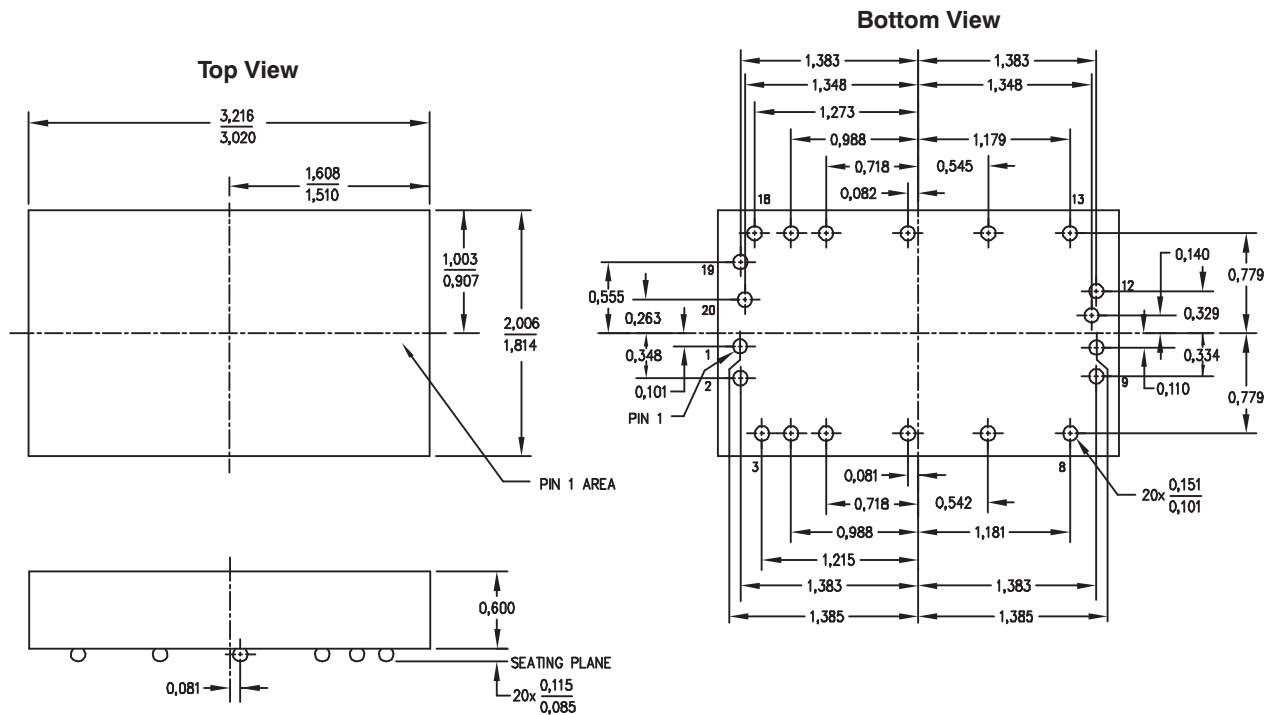

- A. All linear dimensions are in millimeters.
- B. This drawing is subject to change without notice.

Figure 10. TLV5610IYZ Wafer Chip-Scale Package

Revision History

NOTE: Page numbers for previous revisions may differ from page numbers in the current version.

Changes from Original (July 2006) to A Revision	Page
• Deleted separate INL and DNL specifications for Code 20 to 1023; not relevant to this device.....	3
• Replaced timing diagram	4
• Updated Digital Input Timing Requirements Table	4

PACKAGING INFORMATION

Orderable Device	Status (1)	Package Type	Package Drawing	Pins	Package Qty	Eco Plan (2)	Lead/Ball Finish	MSL Peak Temp (3)	Op Temp (°C)	Top-Side Markings (4)	Samples
TLV5610IYZR	ACTIVE	DSBGA	YZ	20	3000	Green (RoHS & no Sb/Br)	SNAGCU	Level-NC-NC-UNLIM	-40 to 85	TLV5610YZ	Samples
TLV5610IYZT	ACTIVE	DSBGA	YZ	20	250	Green (RoHS & no Sb/Br)	SNAGCU	Level-NC-NC-UNLIM	-40 to 85	TLV5610YZ	Samples

(1) The marketing status values are defined as follows:

ACTIVE: Product device recommended for new designs.

LIFEBUY: TI has announced that the device will be discontinued, and a lifetime-buy period is in effect.

NRND: Not recommended for new designs. Device is in production to support existing customers, but TI does not recommend using this part in a new design.

PREVIEW: Device has been announced but is not in production. Samples may or may not be available.

OBSELETE: TI has discontinued the production of the device.

(2) Eco Plan - The planned eco-friendly classification: Pb-Free (RoHS), Pb-Free (RoHS Exempt), or Green (RoHS & no Sb/Br) - please check <http://www.ti.com/productcontent> for the latest availability information and additional product content details.

TBD: The Pb-Free/Green conversion plan has not been defined.

Pb-Free (RoHS): TI's terms "Lead-Free" or "Pb-Free" mean semiconductor products that are compatible with the current RoHS requirements for all 6 substances, including the requirement that lead not exceed 0.1% by weight in homogeneous materials. Where designed to be soldered at high temperatures, TI Pb-Free products are suitable for use in specified lead-free processes.

Pb-Free (RoHS Exempt): This component has a RoHS exemption for either 1) lead-based flip-chip solder bumps used between the die and package, or 2) lead-based die adhesive used between the die and leadframe. The component is otherwise considered Pb-Free (RoHS compatible) as defined above.

Green (RoHS & no Sb/Br): TI defines "Green" to mean Pb-Free (RoHS compatible), and free of Bromine (Br) and Antimony (Sb) based flame retardants (Br or Sb do not exceed 0.1% by weight in homogeneous material)

(3) MSL, Peak Temp. -- The Moisture Sensitivity Level rating according to the JEDEC industry standard classifications, and peak solder temperature.

(4) Multiple Top-Side Markings will be inside parentheses. Only one Top-Side Marking contained in parentheses and separated by a "~" will appear on a device. If a line is indented then it is a continuation of the previous line and the two combined represent the entire Top-Side Marking for that device.

Important Information and Disclaimer:The information provided on this page represents TI's knowledge and belief as of the date that it is provided. TI bases its knowledge and belief on information provided by third parties, and makes no representation or warranty as to the accuracy of such information. Efforts are underway to better integrate information from third parties. TI has taken and continues to take reasonable steps to provide representative and accurate information but may not have conducted destructive testing or chemical analysis on incoming materials and chemicals. TI and TI suppliers consider certain information to be proprietary, and thus CAS numbers and other limited information may not be available for release.

In no event shall TI's liability arising out of such information exceed the total purchase price of the TI part(s) at issue in this document sold by TI to Customer on an annual basis.

TAPE AND REEL INFORMATION

QUADRANT ASSIGNMENTS FOR PIN 1 ORIENTATION IN TAPE

*All dimensions are nominal

Device	Package Type	Package Drawing	Pins	SPQ	Reel Diameter (mm)	Reel Width W1 (mm)	A0 (mm)	B0 (mm)	K0 (mm)	P1 (mm)	W (mm)	Pin1 Quadrant
TLV5610IYZR	DSBGA	YZ	20	3000	180.0	8.4	2.18	3.18	1.0	4.0	8.0	Q2
TLV5610IYZT	DSBGA	YZ	20	250	180.0	8.4	2.18	3.18	1.0	4.0	8.0	Q2

TAPE AND REEL BOX DIMENSIONS

*All dimensions are nominal

Device	Package Type	Package Drawing	Pins	SPQ	Length (mm)	Width (mm)	Height (mm)
TLV5610IYZR	DSBGA	YZ	20	3000	220.0	220.0	34.0
TLV5610IYZT	DSBGA	YZ	20	250	220.0	220.0	34.0

IMPORTANT NOTICE

Texas Instruments Incorporated and its subsidiaries (TI) reserve the right to make corrections, enhancements, improvements and other changes to its semiconductor products and services per JESD46, latest issue, and to discontinue any product or service per JESD48, latest issue. Buyers should obtain the latest relevant information before placing orders and should verify that such information is current and complete. All semiconductor products (also referred to herein as "components") are sold subject to TI's terms and conditions of sale supplied at the time of order acknowledgment.

TI warrants performance of its components to the specifications applicable at the time of sale, in accordance with the warranty in TI's terms and conditions of sale of semiconductor products. Testing and other quality control techniques are used to the extent TI deems necessary to support this warranty. Except where mandated by applicable law, testing of all parameters of each component is not necessarily performed.

TI assumes no liability for applications assistance or the design of Buyers' products. Buyers are responsible for their products and applications using TI components. To minimize the risks associated with Buyers' products and applications, Buyers should provide adequate design and operating safeguards.

TI does not warrant or represent that any license, either express or implied, is granted under any patent right, copyright, mask work right, or other intellectual property right relating to any combination, machine, or process in which TI components or services are used. Information published by TI regarding third-party products or services does not constitute a license to use such products or services or a warranty or endorsement thereof. Use of such information may require a license from a third party under the patents or other intellectual property of the third party, or a license from TI under the patents or other intellectual property of TI.

Reproduction of significant portions of TI information in TI data books or data sheets is permissible only if reproduction is without alteration and is accompanied by all associated warranties, conditions, limitations, and notices. TI is not responsible or liable for such altered documentation. Information of third parties may be subject to additional restrictions.

Resale of TI components or services with statements different from or beyond the parameters stated by TI for that component or service voids all express and any implied warranties for the associated TI component or service and is an unfair and deceptive business practice. TI is not responsible or liable for any such statements.

Buyer acknowledges and agrees that it is solely responsible for compliance with all legal, regulatory and safety-related requirements concerning its products, and any use of TI components in its applications, notwithstanding any applications-related information or support that may be provided by TI. Buyer represents and agrees that it has all the necessary expertise to create and implement safeguards which anticipate dangerous consequences of failures, monitor failures and their consequences, lessen the likelihood of failures that might cause harm and take appropriate remedial actions. Buyer will fully indemnify TI and its representatives against any damages arising out of the use of any TI components in safety-critical applications.

In some cases, TI components may be promoted specifically to facilitate safety-related applications. With such components, TI's goal is to help enable customers to design and create their own end-product solutions that meet applicable functional safety standards and requirements. Nonetheless, such components are subject to these terms.

No TI components are authorized for use in FDA Class III (or similar life-critical medical equipment) unless authorized officers of the parties have executed a special agreement specifically governing such use.

Only those TI components which TI has specifically designated as military grade or "enhanced plastic" are designed and intended for use in military/aerospace applications or environments. Buyer acknowledges and agrees that any military or aerospace use of TI components which have **not** been so designated is solely at the Buyer's risk, and that Buyer is solely responsible for compliance with all legal and regulatory requirements in connection with such use.

TI has specifically designated certain components as meeting ISO/TS16949 requirements, mainly for automotive use. In any case of use of non-designated products, TI will not be responsible for any failure to meet ISO/TS16949.

Products

Audio	www.ti.com/audio
Amplifiers	amplifier.ti.com
Data Converters	dataconverter.ti.com
DLP® Products	www.dlp.com
DSP	dsp.ti.com
Clocks and Timers	www.ti.com/clocks
Interface	interface.ti.com
Logic	logic.ti.com
Power Mgmt	power.ti.com
Microcontrollers	microcontroller.ti.com
RFID	www.ti-rfid.com
OMAP Applications Processors	www.ti.com/omap
Wireless Connectivity	www.ti.com/wirelessconnectivity

Applications

Automotive and Transportation	www.ti.com/automotive
Communications and Telecom	www.ti.com/communications
Computers and Peripherals	www.ti.com/computers
Consumer Electronics	www.ti.com/consumer-apps
Energy and Lighting	www.ti.com/energy
Industrial	www.ti.com/industrial
Medical	www.ti.com/medical
Security	www.ti.com/security
Space, Avionics and Defense	www.ti.com/space-avionics-defense
Video and Imaging	www.ti.com/video

TI E2E Community

e2e.ti.com