

DS90CP02 1.5 Gbps 2x2 LVDS Crosspoint Switch

Check for Samples: [DS90CP02](#)

FEATURES

- 1.5 Gbps per Channel
- Low Power: 70 mA in Dual Repeater Mode @1.5 Gbps
- Low Output Jitter
- Non-Blocking Architecture Allows 1:2 Splitter, 2:1 Mux, Crossover, and Dual Buffer Configurations
- Flow-Through Pinout
- LVDS/BLVDS/CML/LVPECL Inputs, LVDS Outputs
- Single 3.3V Supply
- Separate Control of Inputs and Outputs Allows for Power Savings
- Industrial -40 to +85°C Temperature Range
- 28-lead UQFN-28 Space Saving Package

DESCRIPTION

The DS90CP02 is a 1.5 Gbps 2 x 2 LVDS crosspoint switch optimized for high-speed signal routing and switching over lossy FR-4 printed circuit board backplanes and balanced cables. Fully differential signal paths ensure exceptional signal integrity and noise immunity. The non-blocking architecture allows connections of any input to any output or outputs.

Wide input common mode range allows the switch to accept signals with LVDS, CML and LVPECL levels; the output levels are LVDS. A very small package footprint requires a minimal space on the board while the flow-through pinout allows easy board layout. The 3.3V supply, CMOS process, and LVDS I/O ensure high performance at low power over the entire industrial -40 to +85°C temperature range.

Block Diagram

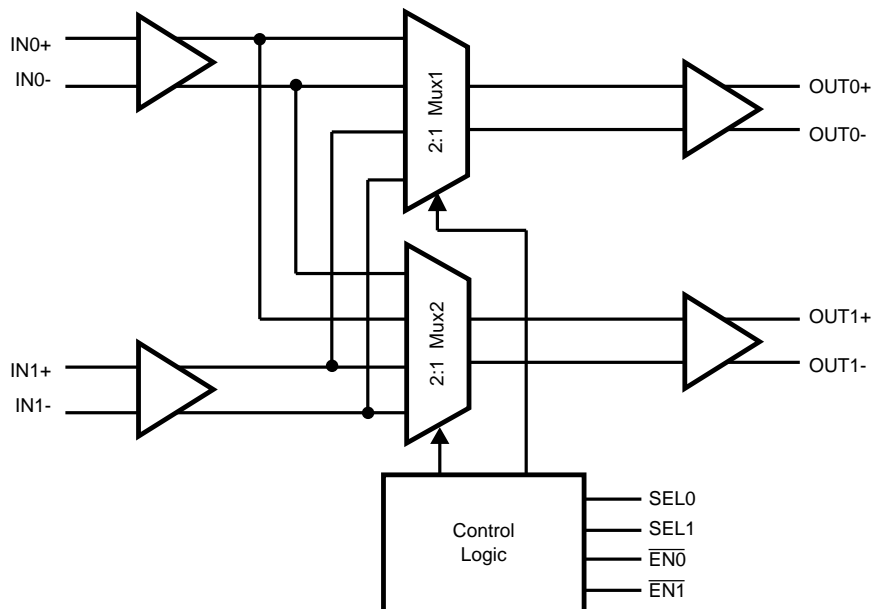

Figure 1. DS90CP02 Block Diagram



Please be aware that an important notice concerning availability, standard warranty, and use in critical applications of Texas Instruments semiconductor products and disclaimers thereto appears at the end of this data sheet.

All trademarks are the property of their respective owners.

Table 1. PIN DESCRIPTIONS

Pin Name	Pin Number	I/O, Type	Description
DIFFERENTIAL INPUTS COMMON TO ALL MUXES			
IN0+ IN0-	9 10	I, LVDS	Inverting and non-inverting differential inputs. LVDS, Bus LVDS, CML, or LVPECL compatible.
IN1+ IN1-	12 13	I, LVDS	Inverting and non-inverting differential inputs. LVDS, Bus LVDS, CML, or LVPECL compatible.
SWITCHED DIFFERENTIAL OUTPUTS			
OUT0+ OUT0-	27 26	O, LVDS	Inverting and non-inverting differential outputs. OUT0± can be connected to any one pair IN0±, or IN1±. LVDS compatible .
OUT1+ OUT1-	24 23	O, LVDS	Inverting and non-inverting differential outputs. OUT1± can be connected to any one pair IN0±, or IN1±. LVDS compatible .
DIGITAL CONTROL INTERFACE			
SEL0, SEL1	6 5	I, LVTTTL	Select Control Inputs
EN0, EN1	7 15	I, LVTTTL	Output Enable Inputs
N/C	8, 20, 28		Not Connected
POWER			
V _{DD}	11, 14, 16, 18, 19, 22, 25	I, Power	V _{DD} = 3.3V ±0.3V. At least 4 low ESR 0.01 µF bypass capacitors should be connected from V _{DD} to GND plane.
GND	DAP, 1, 2, 3, 4, 17, 21	I, Power	Ground reference to LVDS and CMOS circuitry. For the UQFN package, the DAP is used as the primary GND connection to the device. The DAP is the exposed metal contact at the bottom of the UQFN-28 package. It should be connected to the ground plane with at least 4 vias for optimal AC and thermal performance.

Connection Diagram

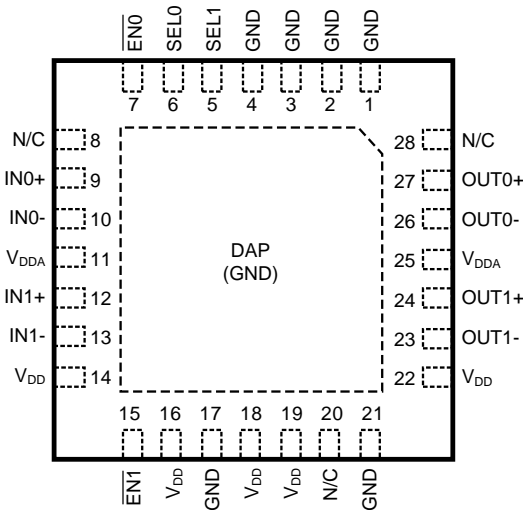

**Figure 2. UQFN Top View
DAP = GND
See Package Number NJD0028A**

Configuration Select Truth Table

SEL0	SEL1	$\overline{\text{EN0}}$	$\overline{\text{EN1}}$	OUT0	OUT1	Mode
0	0	0	0	IN0	IN0	1:2 Splitter (IN1 powered down)
0	1	0	0	IN0	IN1	Dual Channel Repeater
1	0	0	0	IN1	IN0	Dual Channel Switch
1	1	0	0	IN1	IN1	1:2 Splitter (IN0 powered down)
0	1	0	1	IN0	PD	Single Channel Repeater (Channel 1 powered down)
1	1	0	1	IN1	PD	Single Channel Switch (IN0 and OUT1 powered down)
0	0	1	0	PD	IN0	Single Channel Switch (IN1 and OUT0 powered down)
0	1	1	0	PD	IN1	Single Channel Repeater (Channel 0 powered down)
X	X	1	1	PD	PD	Both Channels in Power Down Mode
0	0	0	1			Invalid State*
1	0	0	1			Invalid State*
1	0	1	0			Invalid State*
1	1	1	0			Invalid State*

APPLICATION INFORMATION

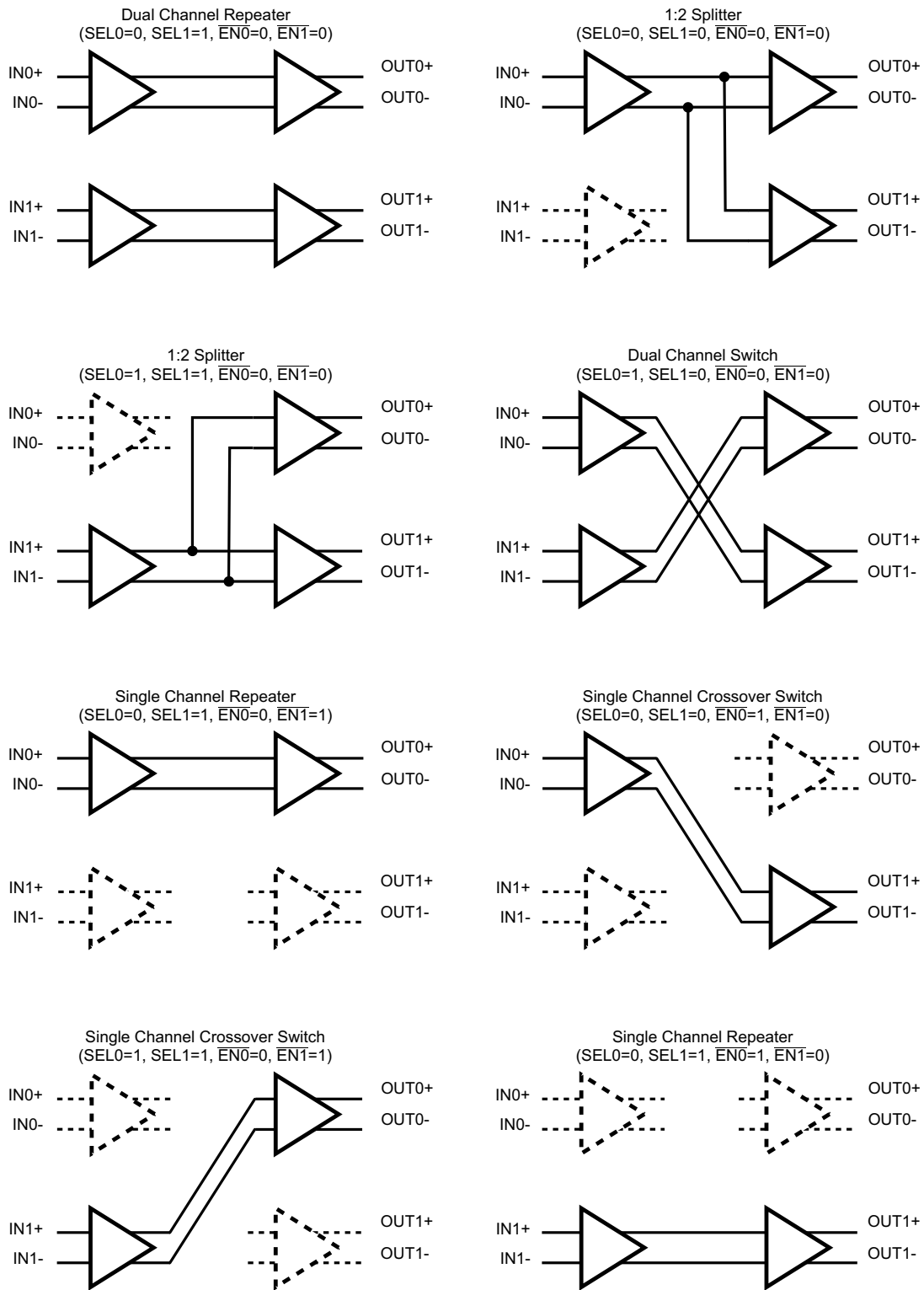

Figure 3. DS90CP02 Configuration Select Decode



These devices have limited built-in ESD protection. The leads should be shorted together or the device placed in conductive foam during storage or handling to prevent electrostatic damage to the MOS gates.

Absolute Maximum Ratings ⁽¹⁾⁽²⁾

Supply Voltage (V_{DD})	-0.3V to +4.0V
CMOS Input Voltage	-0.3V to ($V_{DD} + 0.3V$)
LVDS Receiver Input Voltage	-0.3V to +3.6V
LVDS Driver Output Voltage	-0.3V to +3.6V
LVDS Output Short Circuit Current	40mA
Junction Temperature	+150°C
Storage Temperature	-65°C to +150°C
Lead Temperature (Soldering, 4sec.)	+260°C
Maximum Package Power Dissipation at 25°C	
UQFN-28	4.31 W
Derating above 25°C	
UQFN-28	34.5 mW/°C
Thermal Resistance, θ_{JA}	
UQFN-28	29°C/W
ESD Rating	
HBM, 1.5 k Ω , 100 pF	6.5 kV
EIAJ, 0 Ω , 200 pF	>250V

- (1) "Absolute Maximum Ratings" are the ratings beyond which the safety of the device cannot be guaranteed. They are not meant to imply that the device should be operated at these limits.
- (2) If Military/Aerospace specified devices are required, please contact the Texas Instruments Sales Office/Distributors for availability and specifications.

Recommended Operating Conditions

	Min	Typ	Max	Unit
Supply Voltage ($V_{DD} - GND$)	3.0	3.3	3.6	V
Receiver Input Voltage	0		3.6	V
Operating Free Air Temperature	-40	25	85	°C
Junction Temperature			150	°C

Electrical Characteristics

Over recommended operating supply and temperature ranges unless other specified.

Symbol	Parameter	Conditions	Min	Typ (1)	Max	Units
LVTTL DC SPECIFICATIONS (SEL0, SEL1, EN1, EN2)						
V _{IH}	High Level Input Voltage		2.0		V _{DD}	V
V _{IL}	Low Level Input Voltage		GND		0.8	V
I _{IH}	High Level Input Current	V _{IN} = V _{DD} = V _{DDMAX}	-10		+10	μA
I _{IL}	Low Level Input Current	V _{IN} = V _{SS} , V _{DD} = V _{DDMAX}	-10		+10	μA
C _{IN1}	Input Capacitance	Any Digital Input Pin to V _{SS}		3.5		pF
V _{CL}	Input Clamp Voltage	I _{CL} = -18 mA	-1.5	-0.8		V
LVDS INPUT DC SPECIFICATIONS (IN0±, IN1±)						
V _{TH}	Differential Input High Threshold ⁽²⁾	V _{CM} = 0.8V or 1.2V or 3.55V, V _{DD} = 3.6V		0	100	mV
V _{TL}	Differential Input Low Threshold	V _{CM} = 0.8V or 1.2V or 3.55V, V _{DD} = 3.6V	-100	0		mV
V _{ID}	Differential Input Voltage	V _{CM} = 0.8V to 3.55V, V _{DD} = 3.6V	100			mV
V _{CMR}	Common Mode Voltage Range	V _{ID} = 150 mV, V _{DD} = 3.6V	0.05		3.55	V
C _{IN2}	Input Capacitance	IN+ or IN- to V _{SS}		3.5		pF
I _{IN}	Input Current	V _{IN} = 3.6V, V _{DD} = V _{DDMAX} or 0V	-10		+10	μA
		V _{IN} = 0V, V _{DD} = V _{DDMAX} or 0V	-10		+10	μA
LVDS OUTPUT DC SPECIFICATIONS (OUT0±, OUT1±)						
V _{OD}	Differential Output Voltage, 0% Pre-emphasis ⁽²⁾	R _L = 100Ω between OUT+ and OUT-	250	400	575	mV
ΔV _{OD}	Change in V _{OD} between Complementary States		-35		35	mV
V _{OS}	Offset Voltage ⁽³⁾		1.09	1.25	1.475	V
ΔV _{OS}	Change in V _{OS} between Complementary States		-35		35	mV
I _{OS}	Output Short Circuit Current, One Complementary Output	OUT+ or OUT- Short to GND		-60	-90	mA
C _{OUT}	Output Capacitance	OUT+ or OUT- to GND when TRI-STATE		5.5		pF
SUPPLY CURRENT (Static)						
I _{CC0}	Supply Current	All inputs and outputs enabled and active, terminated with differential load of 100Ω between OUT+ and OUT-.		42	60	mA
I _{CC1}	Supply Current - one channel powered down	Single channel crossover switch or single channel repeater modes (1 channel active, one channel in power down mode)		22	30	mA
I _{CC2}	Supply Current - one input powered down	Splitter mode (One input powered down, both outputs active)		30	40	mA
I _{CCZ}	TRI-STATE Supply Current	Both input/output Channels in Power Down Mode		1.4	2.5	mA
SWITCHING CHARACTERISTICS—LVDS OUTPUTS (Figure 4, Figure 5)						
t _{LHT}	Differential Low to High Transition Time	Use an alternating 1 and 0 pattern at 200 Mb/s, measure between 20% and 80% of V _{OD} .	70	150	215	ps
t _{HLT}	Differential High to Low Transition Time		50	135	180	ps
t _{PLHD}	Differential Low to High Propagation Delay	Use an alternating 1 and 0 pattern at 200 Mb/s, measure at 50% V _{OD} between input to output.	0.5	2.4	3.5	ns
t _{PHLD}	Differential High to Low Propagation Delay		0.5	2.4	3.5	ns
t _{SKD1}	Pulse Skew	t _{PLHD} - t _{PHLD}		55	120	ps

(1) Typical parameters are measured at V_{DD} = 3.3V, T_A = 25°C. They are for reference purposes, and are not production-tested.

(2) Differential output voltage V_{OD} is defined as ABS(OUT+ - OUT-). Differential input voltage V_{ID} is defined as ABS(IN+ - IN-).

(3) Output offset voltage V_{OS} is defined as the average of the LVDS single-ended output voltages at logic high and logic low states.

Electrical Characteristics (continued)

Over recommended operating supply and temperature ranges unless other specified.

Symbol	Parameter	Conditions	Min	Typ (1)	Max	Units
t_{SKCC}	Output Channel to Channel Skew	Difference in propagation delay (t_{PLHD} or t_{PHLD}) among all output channels in Splitter mode (any one input to all outputs).	0	130	315	ps
t_{JIT}	Jitter (4)	RJ - Clock Pattern 750 MHz (5)		1.4	2.5	psrms
		DJ - K28.5 Pattern 1.5 Gbps (6)		42	75	psp-p
		TJ - PRBS $2^{23}-1$ Pattern 1.5 Gbps (7)		93	126	psp-p
t_{ON}	LVDS Output Enable Time	Time from \overline{ENx} to OUT_{\pm} change from TRI-STATE to active.	50	110	150	ns
t_{OFF}	LVDS Output Disable Time	Time from \overline{ENx} to OUT_{\pm} change from active to TRI-STATE.		5	12	ns
t_{SW}	LVDS Switching Time SELx to OUT_{\pm}	Time from configuration select (SELx) to new switch configuration effective for OUT_{\pm} .		110	150	ns

(4) Jitter is not production tested, but guaranteed through characterization on a sample basis.

(5) Random Jitter, or RJ, is measured RMS with a histogram including 1500 histogram window hits. The input voltage = $V_{ID} = 500mV$, 50% duty cycle at 750MHz, $t_r = t_f = 50ps$ (20% to 80%).

(6) Deterministic Jitter, or DJ, is measured to a histogram mean with a sample size of 350 hits. The input voltage = $V_{ID} = 500mV$, K28.5 pattern at 1.5 Gbps, $t_r = t_f = 50ps$ (20% to 80%). The K28.5 pattern is repeating bit streams of (0011111010 1100000101).

(7) Total Jitter, or TJ, is measured peak to peak with a histogram including 3500 window hits. Stimulus and fixture jitter has been subtracted. The input voltage = $V_{ID} = 500mV$, $2^{23}-1$ PRBS pattern at 1.5 Gbps, $t_r = t_f = 50ps$ (20% to 80%).

Timing Diagrams

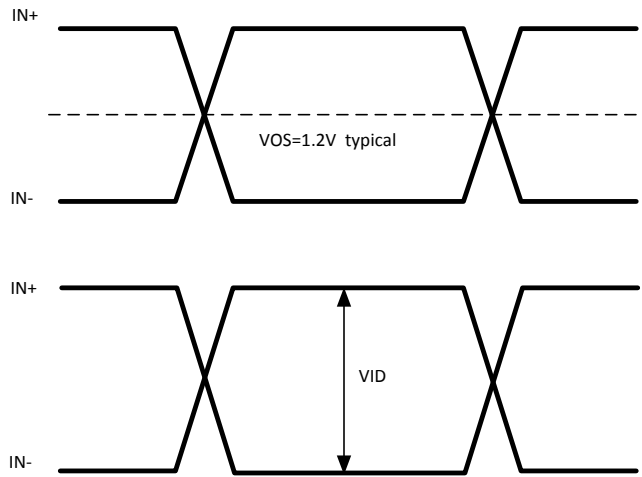

Figure 4. LVDS Signals

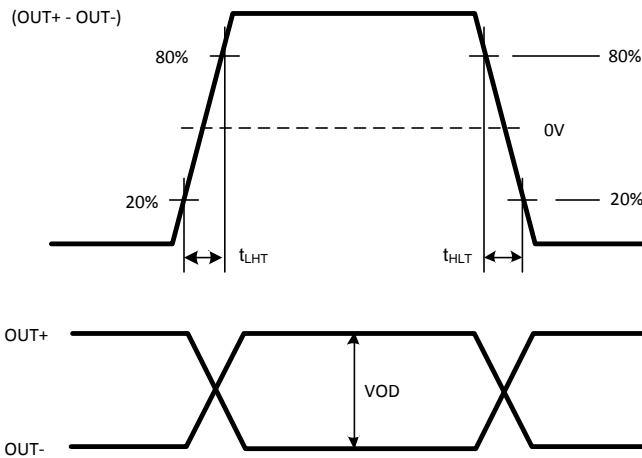

Figure 5. LVDS Output Transition Time

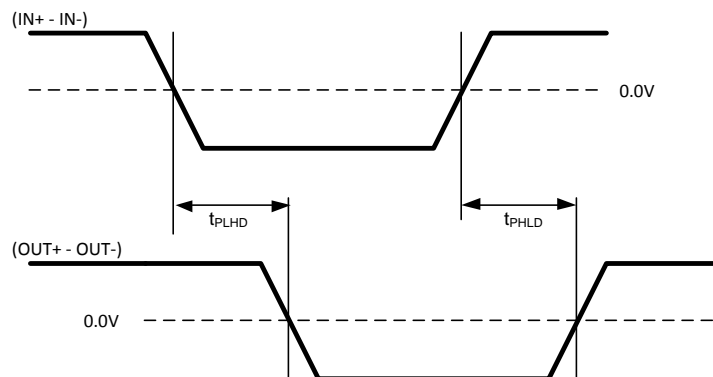

Figure 6. LVDS Output Propagation Delay

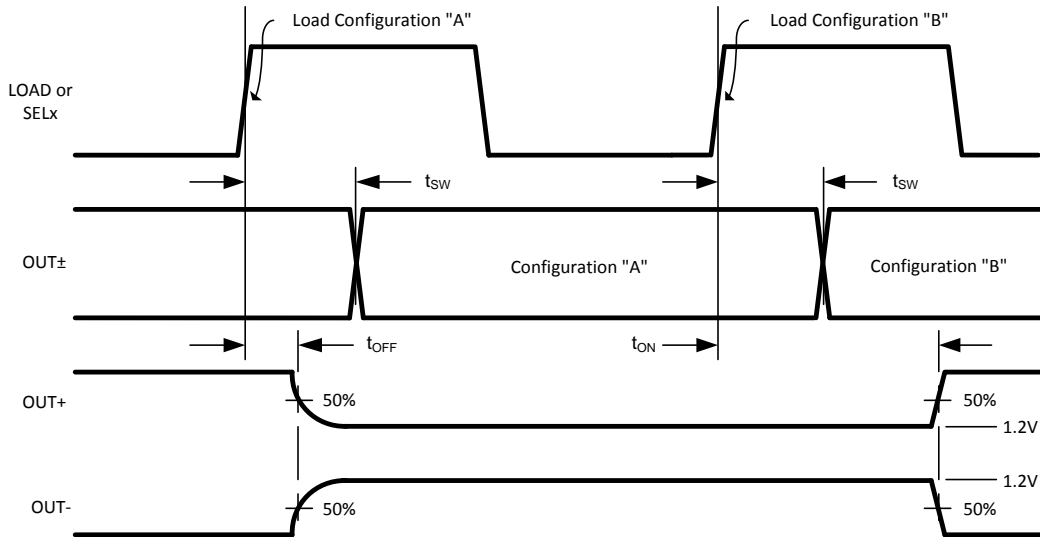
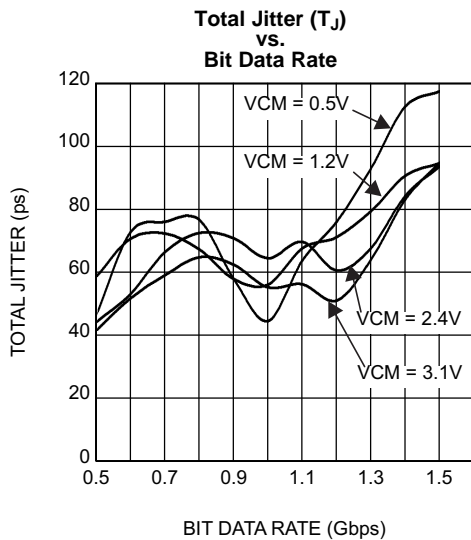

Figure 7. Configuration and Output Enable/Disable Timing

Typical Performance



Total Jitter measured at 0V differential while running a PRBS 2²³-1 pattern in single channel repeater mode. V_{CC} = 3.3V, T_A = +25°C, V_{ID} = 0.5V

Figure 8.

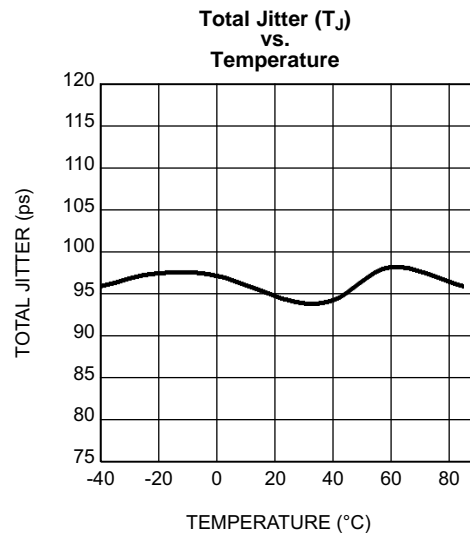

Total Jitter measured at 0V differential while running a PRBS 2²³-1 pattern in dual channel repeater mode. V_{CC} = 3.3V, V_{ID} = 0.5V, V_{CM} = 1.2V, 1.5 Gbps data rate

Figure 9.

REVISION HISTORY

Changes from Original (March 2013) to Revision A	Page
• Changed layout of National Data Sheet to TI format	9

PACKAGING INFORMATION

Orderable Device	Status (1)	Package Type	Package Drawing	Pins	Package Qty	Eco Plan (2)	Lead/Ball Finish (6)	MSL Peak Temp (3)	Op Temp (°C)	Device Marking (4/5)	Samples
DS90CP02SP/NOPB	ACTIVE	UQFN	NJD	28	1000	Green (RoHS & no Sb/Br)	CU SN	Level-3-260C-168 HR	-40 to 85	CP02SP	Samples

(1) The marketing status values are defined as follows:

ACTIVE: Product device recommended for new designs.

LIFEBUY: TI has announced that the device will be discontinued, and a lifetime-buy period is in effect.

NRND: Not recommended for new designs. Device is in production to support existing customers, but TI does not recommend using this part in a new design.

PREVIEW: Device has been announced but is not in production. Samples may or may not be available.

OBSOLETE: TI has discontinued the production of the device.

(2) Eco Plan - The planned eco-friendly classification: Pb-Free (RoHS), Pb-Free (RoHS Exempt), or Green (RoHS & no Sb/Br) - please check <http://www.ti.com/productcontent> for the latest availability information and additional product content details.

TBD: The Pb-Free/Green conversion plan has not been defined.

Pb-Free (RoHS): TI's terms "Lead-Free" or "Pb-Free" mean semiconductor products that are compatible with the current RoHS requirements for all 6 substances, including the requirement that lead not exceed 0.1% by weight in homogeneous materials. Where designed to be soldered at high temperatures, TI Pb-Free products are suitable for use in specified lead-free processes.

Pb-Free (RoHS Exempt): This component has a RoHS exemption for either 1) lead-based flip-chip solder bumps used between the die and package, or 2) lead-based die adhesive used between the die and leadframe. The component is otherwise considered Pb-Free (RoHS compatible) as defined above.

Green (RoHS & no Sb/Br): TI defines "Green" to mean Pb-Free (RoHS compatible), and free of Bromine (Br) and Antimony (Sb) based flame retardants (Br or Sb do not exceed 0.1% by weight in homogeneous material)

(3) MSL, Peak Temp. - The Moisture Sensitivity Level rating according to the JEDEC industry standard classifications, and peak solder temperature.

(4) There may be additional marking, which relates to the logo, the lot trace code information, or the environmental category on the device.

(5) Multiple Device Markings will be inside parentheses. Only one Device Marking contained in parentheses and separated by a "~" will appear on a device. If a line is indented then it is a continuation of the previous line and the two combined represent the entire Device Marking for that device.

(6) Lead/Ball Finish - Orderable Devices may have multiple material finish options. Finish options are separated by a vertical ruled line. Lead/Ball Finish values may wrap to two lines if the finish value exceeds the maximum column width.

Important Information and Disclaimer: The information provided on this page represents TI's knowledge and belief as of the date that it is provided. TI bases its knowledge and belief on information provided by third parties, and makes no representation or warranty as to the accuracy of such information. Efforts are underway to better integrate information from third parties. TI has taken and continues to take reasonable steps to provide representative and accurate information but may not have conducted destructive testing or chemical analysis on incoming materials and chemicals. TI and TI suppliers consider certain information to be proprietary, and thus CAS numbers and other limited information may not be available for release.

In no event shall TI's liability arising out of such information exceed the total purchase price of the TI part(s) at issue in this document sold by TI to Customer on an annual basis.

TAPE AND REEL INFORMATION



QUADRANT ASSIGNMENTS FOR PIN 1 ORIENTATION IN TAPE



*All dimensions are nominal

Device	Package Type	Package Drawing	Pins	SPQ	Reel Diameter (mm)	Reel Width W1 (mm)	A0 (mm)	B0 (mm)	K0 (mm)	P1 (mm)	W (mm)	Pin1 Quadrant
DS90CP02SP/NOPB	UQFN	NJD	28	1000	178.0	12.4	5.3	5.3	1.3	8.0	12.0	Q1

TAPE AND REEL BOX DIMENSIONS



*All dimensions are nominal

Device	Package Type	Package Drawing	Pins	SPQ	Length (mm)	Width (mm)	Height (mm)
DS90CP02SP/NOPB	UQFN	NJD	28	1000	210.0	185.0	35.0

NJD0028A

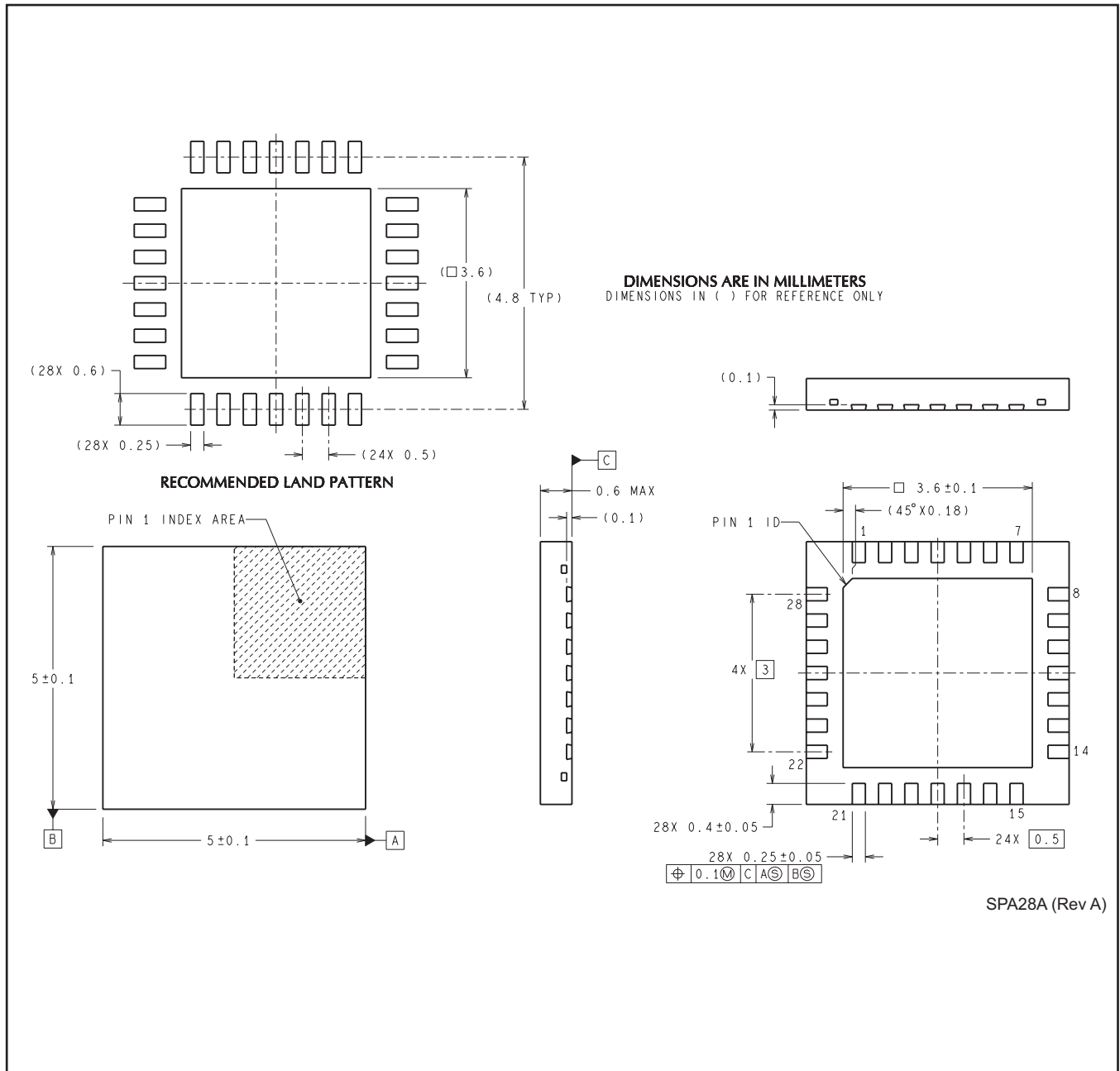

IMPORTANT NOTICE

Texas Instruments Incorporated and its subsidiaries (TI) reserve the right to make corrections, enhancements, improvements and other changes to its semiconductor products and services per JESD46, latest issue, and to discontinue any product or service per JESD48, latest issue. Buyers should obtain the latest relevant information before placing orders and should verify that such information is current and complete. All semiconductor products (also referred to herein as "components") are sold subject to TI's terms and conditions of sale supplied at the time of order acknowledgment.

TI warrants performance of its components to the specifications applicable at the time of sale, in accordance with the warranty in TI's terms and conditions of sale of semiconductor products. Testing and other quality control techniques are used to the extent TI deems necessary to support this warranty. Except where mandated by applicable law, testing of all parameters of each component is not necessarily performed.

TI assumes no liability for applications assistance or the design of Buyers' products. Buyers are responsible for their products and applications using TI components. To minimize the risks associated with Buyers' products and applications, Buyers should provide adequate design and operating safeguards.

TI does not warrant or represent that any license, either express or implied, is granted under any patent right, copyright, mask work right, or other intellectual property right relating to any combination, machine, or process in which TI components or services are used. Information published by TI regarding third-party products or services does not constitute a license to use such products or services or a warranty or endorsement thereof. Use of such information may require a license from a third party under the patents or other intellectual property of the third party, or a license from TI under the patents or other intellectual property of TI.

Reproduction of significant portions of TI information in TI data books or data sheets is permissible only if reproduction is without alteration and is accompanied by all associated warranties, conditions, limitations, and notices. TI is not responsible or liable for such altered documentation. Information of third parties may be subject to additional restrictions.

Resale of TI components or services with statements different from or beyond the parameters stated by TI for that component or service voids all express and any implied warranties for the associated TI component or service and is an unfair and deceptive business practice. TI is not responsible or liable for any such statements.

Buyer acknowledges and agrees that it is solely responsible for compliance with all legal, regulatory and safety-related requirements concerning its products, and any use of TI components in its applications, notwithstanding any applications-related information or support that may be provided by TI. Buyer represents and agrees that it has all the necessary expertise to create and implement safeguards which anticipate dangerous consequences of failures, monitor failures and their consequences, lessen the likelihood of failures that might cause harm and take appropriate remedial actions. Buyer will fully indemnify TI and its representatives against any damages arising out of the use of any TI components in safety-critical applications.

In some cases, TI components may be promoted specifically to facilitate safety-related applications. With such components, TI's goal is to help enable customers to design and create their own end-product solutions that meet applicable functional safety standards and requirements. Nonetheless, such components are subject to these terms.

No TI components are authorized for use in FDA Class III (or similar life-critical medical equipment) unless authorized officers of the parties have executed a special agreement specifically governing such use.

Only those TI components which TI has specifically designated as military grade or "enhanced plastic" are designed and intended for use in military/aerospace applications or environments. Buyer acknowledges and agrees that any military or aerospace use of TI components which have **not** been so designated is solely at the Buyer's risk, and that Buyer is solely responsible for compliance with all legal and regulatory requirements in connection with such use.

TI has specifically designated certain components as meeting ISO/TS16949 requirements, mainly for automotive use. In any case of use of non-designated products, TI will not be responsible for any failure to meet ISO/TS16949.

Products

Audio	www.ti.com/audio
Amplifiers	amplifier.ti.com
Data Converters	dataconverter.ti.com
DLP® Products	www.dlp.com
DSP	dsp.ti.com
Clocks and Timers	www.ti.com/clocks
Interface	interface.ti.com
Logic	logic.ti.com
Power Mgmt	power.ti.com
Microcontrollers	microcontroller.ti.com
RFID	www.ti-rfid.com
OMAP Applications Processors	www.ti.com/omap
Wireless Connectivity	www.ti.com/wirelessconnectivity

Applications

Automotive and Transportation	www.ti.com/automotive
Communications and Telecom	www.ti.com/communications
Computers and Peripherals	www.ti.com/computers
Consumer Electronics	www.ti.com/consumer-apps
Energy and Lighting	www.ti.com/energy
Industrial	www.ti.com/industrial
Medical	www.ti.com/medical
Security	www.ti.com/security
Space, Avionics and Defense	www.ti.com/space-avionics-defense
Video and Imaging	www.ti.com/video

TI E2E Community

e2e.ti.com