

- **Wide Range of Supply Voltages; Single Supply . . . 3 V to 36 V, or Dual Supplies**
- **Class AB Output Stage**
- **High-Impedance N-Channel-JFET Input Stage . . .  $10^{12} \Omega$  Typ**
- **Internal Frequency Compensation**
- **Short-Circuit Protection**
- **Input Common Mode Includes  $V_{CC-}$**
- **Low Input Offset Current . . . 50 pA**
- **Low Input Bias Current . . . 200 pA Typ**

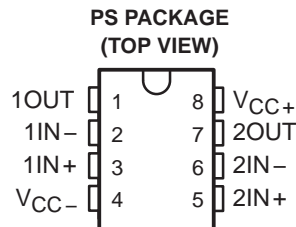

## description

The TL092 JFET-input operational amplifier is similar in performance to the MC3403 family, but with much higher input impedance derived from a FET input stage. The N-channel-JFET input stage allows a common-mode input voltage range that includes the negative supply voltage and offers a typical input impedance of  $10^{12} \Omega$ , a typical input offset current of 50 pA, and a typical input bias current of 200 pA. This device is designed to operate from a single supply over a range of 3 V to 36 V. Operation from split supplies also is possible, provided the difference between the two supplies is 3 V to 36 V. Output voltage range is from  $V_{CC-}$  to  $V_{CC+} - 1.3$  V, with a load resistor to  $V_{CC-}$ .

The TL092 is characterized for operation from 0°C to 70°C.

### AVAILABLE OPTIONS

$T_A$	PACKAGED DEVICE
	PLASTIC SMALL OUTLINE (PS)
0°C to 70°C	TL092CPSR

The PS package is only available taped and reeled. Add the suffix R to device type for ordering (e.g., TL092CPSR).

## symbol

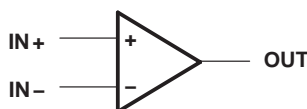

Please be aware that an important notice concerning availability, standard warranty, and use in critical applications of Texas Instruments semiconductor products and disclaimers thereto appears at the end of this data sheet.

PRODUCTION DATA information is current as of publication date. Products conform to specifications per the terms of Texas Instruments standard warranty. Production processing does not necessarily include testing of all parameters.

**TEXAS  
INSTRUMENTS**

POST OFFICE BOX 655303 • DALLAS, TEXAS 75265

Copyright © 2001, Texas Instruments Incorporated

# TL092 DUAL JFET-INPUT OPERATIONAL AMPLIFIER

SLOS372 – JUNE 2001

## schematic

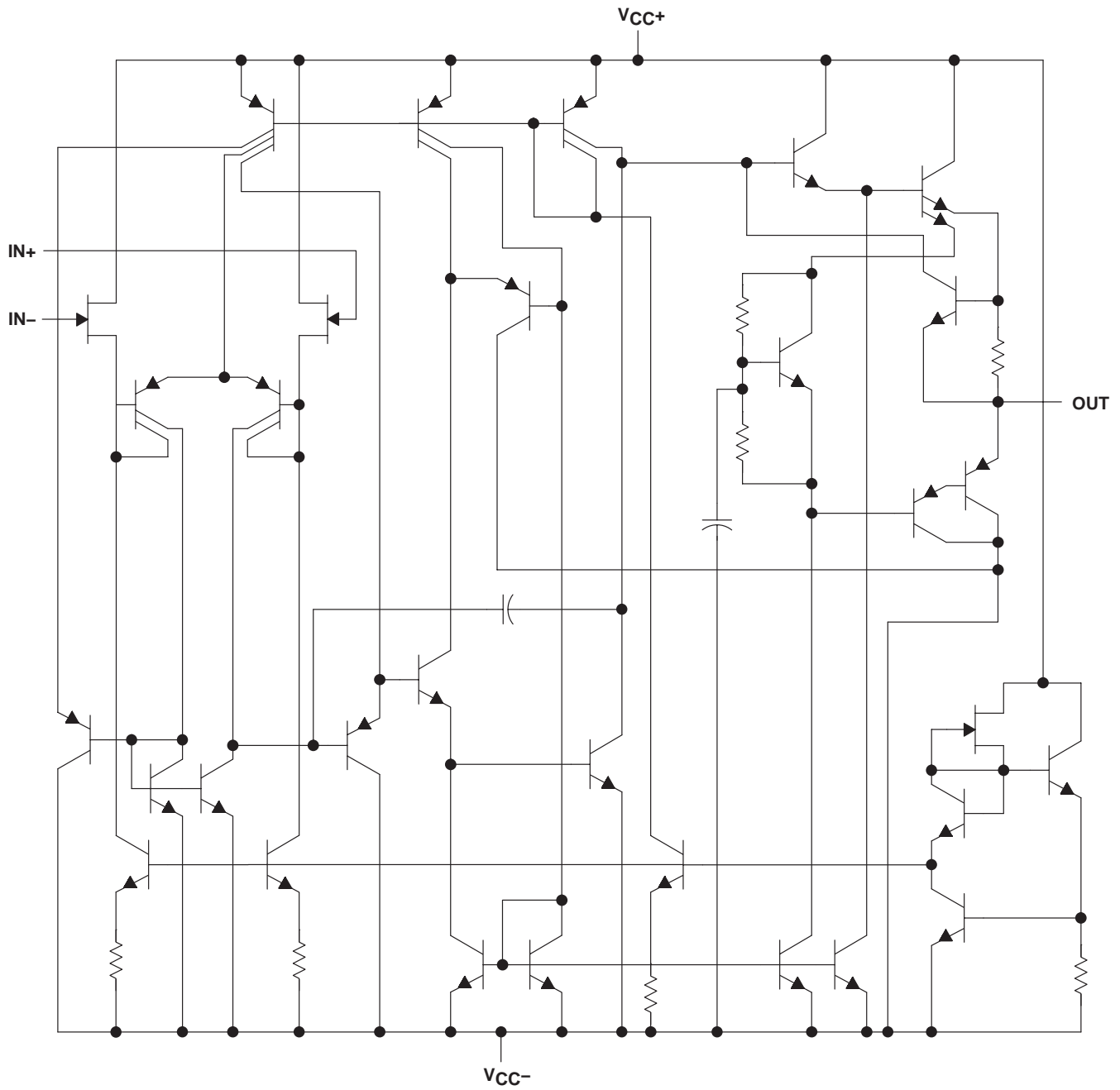

**absolute maximum ratings over operating free-air temperature range (unless otherwise noted)†**

Supply voltage: $V_{CC+}$ (see Note 1) .....	18 V
$V_{CC-}$ (see Note 1) .....	–18 V
$V_{CC+}$ with respect to $V_{CC-}$ .....	36 V
Differential input voltage, $V_{ID}$ (see Note 2) .....	±36 V
Input voltage, $V_I$ (see Notes 1 and 3) .....	±18 V
Package thermal impedance, $\theta_{JA}$ (see Notes 4 and 5) .....	95°C/W
Lead temperature 1.6 mm (1/16 inch) from case for 10 seconds .....	260°C
Storage temperature range, $T_{stg}$ .....	–65°C to 150°C

† Stresses beyond those listed under “absolute maximum ratings” may cause permanent damage to the device. These are stress ratings only, and functional operation of the device at these or any other conditions beyond those indicated under “recommended operating conditions” is not implied. Exposure to absolute-maximum-rated conditions for extended periods may affect device reliability.

- NOTES:
1. All voltage values, except differential voltages, are with respect to the midpoint between  $V_{CC+}$  and  $V_{CC-}$ .
  2. Differential voltages are at the noninverting input with respect to the inverting input.
  3. Neither input must ever be more positive than  $V_{CC+}$  or more negative than  $V_{CC-} - 0.3$  V.
  4. Maximum power dissipation is a function of  $T_J(\text{max})$ ,  $\theta_{JA}$ , and  $T_A$ . The maximum allowable power dissipation at any allowable ambient temperature is  $P_D = (T_J(\text{max}) - T_A)/\theta_{JA}$ . Operating at the absolute maximum  $T_J$  of 150°C can impact reliability.
  5. The package thermal impedance is calculated in accordance with JESD 51-7.

**recommended operating conditions**

		MIN	MAX	UNIT
$V_{CC\pm}$	Supply voltage	3	36	V
$T_A$	Operating free-air temperature range	0	70	°C

# TL092

## DUAL JFET-INPUT OPERATIONAL AMPLIFIER

SLOS372 – JUNE 2001

**electrical characteristics at specified free-air temperature,  $V_{CC\pm} = \pm 15\text{ V}$   
(all characteristics are specified under open-loop conditions, unless otherwise noted)**

PARAMETER		TEST CONDITIONS		$T_A$	MIN	TYP†	MAX	UNIT
$V_{IO}$	Input offset voltage	$R_S = 50\ \Omega$		25°C		5	15	mV
				Full range			20	
$\alpha_{V_{IO}}$	Temperature coefficient of input offset voltage			25°C		10		$\mu\text{V}/^\circ\text{C}$
$I_{IO}\ddagger$	Input offset current			25°C		50	200	pA
				Full range			5	nA
$I_{IB}\ddagger$	Input bias current			25°C		200	400	pA
				Full range			10	nA
$V_{ICR}$	Common-mode input voltage range			25°C	$V_{CC-}$ to 12	$V_{CC-}$ to 13		V
$V_{O(PP)}$	Peak output voltage swing			25°C	$R_L = 2\ \text{k}\Omega$	$\pm 10$	$\pm 13$	V
				25°C	$R_L = 10\ \text{k}\Omega$	$\pm 12$	$\pm 13.5$	
				Full range	$R_L = 2\ \text{k}\Omega$	$\pm 10$		
$A_{VD}$	Large-signal differential voltage amplification	$R_L = 2\ \text{k}\Omega$	$V_O = \pm 10\ \text{V}$	25°C		20	200	V/mV
				Full range		15		
$B_{OM}$	Maximum output swing bandwidth	$R_L = 2\ \text{k}\Omega$	$V_{O(PP)} = 20\ \text{V}$ , THD < 5%	25°C		9		kHz
$B_1$	Unity gain bandwidth	$R_L = 10\ \text{k}\Omega$	$V_O = 50\ \text{mV}$	25°C		1		MHz
$\phi_m$	Phase margin	$R_L = 2\ \text{k}\Omega$	$C_L = 200\ \text{pF}$	25°C		60°		
$r_i$	Input resistance	$f = 20\ \text{Hz}$		25°C		$10^{12}$		$\Omega$
$r_o$	Output resistance	$f = 20\ \text{Hz}$		25°C		75		$\Omega$
CMRR	Common-mode rejection ratio	$R_S = 50\ \Omega$	$V_{IC} = V_{ICR}$	25°C		70	90	dB
$k_{SVR}$	Supply-voltage rejection ratio ( $\Delta V_{CC}/\Delta V_{IO}$ )	$R_S = 50\ \Omega$	$V_{CC\pm} = \pm 3\ \text{V}$ to $\pm 15\ \text{V}$	25°C		75	90	dB
$I_{OS}$	Short-circuit output current			25°C		40		mA
$I_{CC}$	Supply current (per amplifier)	$V_O = 0$	No load	25°C		1.5	2.5	mA

† All typical values are at  $T_A = 25^\circ\text{C}$ .

‡ Input bias currents of a FET-input operational amplifier are normal junction reverse currents, which are temperature sensitive. Pulse techniques that maintain the junction temperature as close to the ambient temperature as possible must be used.

**electrical characteristics at specified free-air temperature,  $V_{CC+} = 5\ \text{V}$ ,  $V_{CC-} = 0\ \text{V}$ ,  $T_A = 25^\circ\text{C}$   
(unless otherwise noted)**

PARAMETER		TEST CONDITIONS		MIN	TYP†	MAX	UNIT
$V_{IO}$	Input offset voltage	$R_S = 50\ \Omega$	$V_O = 2.5\ \text{V}$		5	15	mV
$I_{IO}$	Input offset current		$V_O = 2.5\ \text{V}$		50	200	pA
$I_{IB}$	Input bias current		$V_O = 2.5\ \text{V}$		200	400	pA
$V_{O(PP)}$	Peak output voltage swing	$R_L = 10\ \text{k}\Omega$		3.3	3.5		V
		$R_L = 10\ \text{k}\Omega$	$V_{CC+} = 5\ \text{V}$ to $30\ \text{V}$	$V_{CC+} - 1.7$			V
$A_{VD}$	Large-signal differential voltage amplification	$R_L = 2\ \text{k}\Omega$	$\Delta V_O = 1.6\ \text{V}$	20	200		V/mV
$k_{SVR}$	Supply-voltage rejection ratio ( $\Delta V_{CC}/\Delta V_{IO}$ )	$R_S = 50\ \Omega$	$V_{CC\pm} = \pm 3\ \text{V}$ to $\pm 15\ \text{V}$	75			dB
$I_{CC}$	Supply current (per amplifier)	$V_O = 2.5\ \text{V}$	No load		1.5	2.5	mA
$V_{O1}/V_{O2}$	Channel separation		$f = 1\ \text{kHz}$ to $20\ \text{kHz}$		120		dB

† All typical values are at  $T_A = 25^\circ\text{C}$ .



operating characteristics,  $V_{CC\pm} = \pm 15\text{ V}$ ,  $T_A = 25^\circ\text{C}$

PARAMETER	TEST CONDITIONS	MIN	TYP	MAX	UNIT
SR	Slew rate at unity gain $V_I = \pm 10\text{ V}$ (see Figure 1), $C_L = 100\text{ pF}$ , $R_L = 2\text{ k}\Omega$		0.6		$\text{V}/\mu\text{s}$
$t_r$	Rise time $\Delta V_O = 50\text{ mV}$ (see Figure 1), $C_L = 100\text{ pF}$ , $R_L = 2\text{ k}\Omega$		0.2		$\mu\text{s}$
$t_f$	Fall time $\Delta V_O = 50\text{ mV}$ (see Figure 1), $C_L = 100\text{ pF}$ , $R_L = 2\text{ k}\Omega$		0.2		$\mu\text{s}$
	Overshoot factor $\Delta V_O = 50\text{ mV}$ (see Figure 1), $C_L = 100\text{ pF}$ , $R_L = 2\text{ k}\Omega$		20%		
	Crossover distortion $V_{I\text{PP}} = 30\text{ mV}$ , $V_{O(\text{PP})} = 2\text{ V}$ , $f = 10\text{ kHz}$		1%		
$V_n$	Equivalent input noise voltage $R_S = 100\ \Omega$ , $f = 1\text{ kHz}$		34		$\text{nV}/\sqrt{\text{Hz}}$

### PARAMETER MEASUREMENT INFORMATION

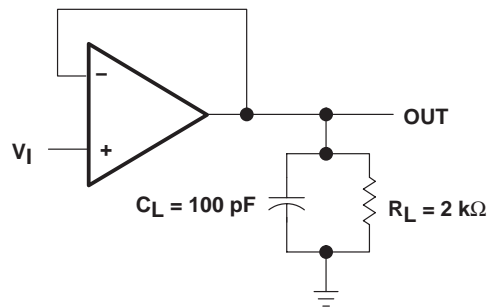

Figure 1. Unity-Gain Amplifier

**PACKAGING INFORMATION**

Orderable Device	Status <sup>(1)</sup>	Package Type	Package Drawing	Pins	Package Qty	Eco Plan <sup>(2)</sup>	Lead/Ball Finish	MSL Peak Temp <sup>(3)</sup>
TL092CPSR	ACTIVE	SO	PS	8	2000	Green (RoHS & no Sb/Br)	CU NIPDAU	Level-1-260C-UNLIM
TL092CPSRE4	ACTIVE	SO	PS	8	2000	Green (RoHS & no Sb/Br)	CU NIPDAU	Level-1-260C-UNLIM
TL092CPSRG4	ACTIVE	SO	PS	8	2000	Green (RoHS & no Sb/Br)	CU NIPDAU	Level-1-260C-UNLIM

<sup>(1)</sup> The marketing status values are defined as follows:

**ACTIVE:** Product device recommended for new designs.

**LIFEBUY:** TI has announced that the device will be discontinued, and a lifetime-buy period is in effect.

**NRND:** Not recommended for new designs. Device is in production to support existing customers, but TI does not recommend using this part in a new design.

**PREVIEW:** Device has been announced but is not in production. Samples may or may not be available.

**OBsolete:** TI has discontinued the production of the device.

<sup>(2)</sup> Eco Plan - The planned eco-friendly classification: Pb-Free (RoHS), Pb-Free (RoHS Exempt), or Green (RoHS & no Sb/Br) - please check <http://www.ti.com/productcontent> for the latest availability information and additional product content details.

**TBD:** The Pb-Free/Green conversion plan has not been defined.

**Pb-Free (RoHS):** TI's terms "Lead-Free" or "Pb-Free" mean semiconductor products that are compatible with the current RoHS requirements for all 6 substances, including the requirement that lead not exceed 0.1% by weight in homogeneous materials. Where designed to be soldered at high temperatures, TI Pb-Free products are suitable for use in specified lead-free processes.

**Pb-Free (RoHS Exempt):** This component has a RoHS exemption for either 1) lead-based flip-chip solder bumps used between the die and package, or 2) lead-based die adhesive used between the die and leadframe. The component is otherwise considered Pb-Free (RoHS compatible) as defined above.

**Green (RoHS & no Sb/Br):** TI defines "Green" to mean Pb-Free (RoHS compatible), and free of Bromine (Br) and Antimony (Sb) based flame retardants (Br or Sb do not exceed 0.1% by weight in homogeneous material)

<sup>(3)</sup> MSL, Peak Temp. -- The Moisture Sensitivity Level rating according to the JEDEC industry standard classifications, and peak solder temperature.

**Important Information and Disclaimer:**The information provided on this page represents TI's knowledge and belief as of the date that it is provided. TI bases its knowledge and belief on information provided by third parties, and makes no representation or warranty as to the accuracy of such information. Efforts are underway to better integrate information from third parties. TI has taken and continues to take reasonable steps to provide representative and accurate information but may not have conducted destructive testing or chemical analysis on incoming materials and chemicals. TI and TI suppliers consider certain information to be proprietary, and thus CAS numbers and other limited information may not be available for release.

In no event shall TI's liability arising out of such information exceed the total purchase price of the TI part(s) at issue in this document sold by TI to Customer on an annual basis.

**TAPE AND REEL INFORMATION**



**QUADRANT ASSIGNMENTS FOR PIN 1 ORIENTATION IN TAPE**



\*All dimensions are nominal

Device	Package Type	Package Drawing	Pins	SPQ	Reel Diameter (mm)	Reel Width W1 (mm)	A0 (mm)	B0 (mm)	K0 (mm)	P1 (mm)	W (mm)	Pin1 Quadrant
TL092CPSR	SO	PS	8	2000	330.0	16.4	8.2	6.6	2.5	12.0	16.0	Q1

**TAPE AND REEL BOX DIMENSIONS**



\*All dimensions are nominal

Device	Package Type	Package Drawing	Pins	SPQ	Length (mm)	Width (mm)	Height (mm)
TL092CPSR	SO	PS	8	2000	346.0	346.0	33.0



## MECHANICAL DATA

PS (R-PDSO-G8)

PLASTIC SMALL-OUTLINE PACKAGE



- NOTES:
- A. All linear dimensions are in millimeters.
  - B. This drawing is subject to change without notice.
  - C. Body dimensions do not include mold flash or protrusion, not to exceed 0,15.

## IMPORTANT NOTICE

Texas Instruments Incorporated and its subsidiaries (TI) reserve the right to make corrections, modifications, enhancements, improvements, and other changes to its products and services at any time and to discontinue any product or service without notice. Customers should obtain the latest relevant information before placing orders and should verify that such information is current and complete. All products are sold subject to TI's terms and conditions of sale supplied at the time of order acknowledgment.

TI warrants performance of its hardware products to the specifications applicable at the time of sale in accordance with TI's standard warranty. Testing and other quality control techniques are used to the extent TI deems necessary to support this warranty. Except where mandated by government requirements, testing of all parameters of each product is not necessarily performed.

TI assumes no liability for applications assistance or customer product design. Customers are responsible for their products and applications using TI components. To minimize the risks associated with customer products and applications, customers should provide adequate design and operating safeguards.

TI does not warrant or represent that any license, either express or implied, is granted under any TI patent right, copyright, mask work right, or other TI intellectual property right relating to any combination, machine, or process in which TI products or services are used. Information published by TI regarding third-party products or services does not constitute a license from TI to use such products or services or a warranty or endorsement thereof. Use of such information may require a license from a third party under the patents or other intellectual property of the third party, or a license from TI under the patents or other intellectual property of TI.

Reproduction of TI information in TI data books or data sheets is permissible only if reproduction is without alteration and is accompanied by all associated warranties, conditions, limitations, and notices. Reproduction of this information with alteration is an unfair and deceptive business practice. TI is not responsible or liable for such altered documentation. Information of third parties may be subject to additional restrictions.

Resale of TI products or services with statements different from or beyond the parameters stated by TI for that product or service voids all express and any implied warranties for the associated TI product or service and is an unfair and deceptive business practice. TI is not responsible or liable for any such statements.

TI products are not authorized for use in safety-critical applications (such as life support) where a failure of the TI product would reasonably be expected to cause severe personal injury or death, unless officers of the parties have executed an agreement specifically governing such use. Buyers represent that they have all necessary expertise in the safety and regulatory ramifications of their applications, and acknowledge and agree that they are solely responsible for all legal, regulatory and safety-related requirements concerning their products and any use of TI products in such safety-critical applications, notwithstanding any applications-related information or support that may be provided by TI. Further, Buyers must fully indemnify TI and its representatives against any damages arising out of the use of TI products in such safety-critical applications.

TI products are neither designed nor intended for use in military/aerospace applications or environments unless the TI products are specifically designated by TI as military-grade or "enhanced plastic." Only products designated by TI as military-grade meet military specifications. Buyers acknowledge and agree that any such use of TI products which TI has not designated as military-grade is solely at the Buyer's risk, and that they are solely responsible for compliance with all legal and regulatory requirements in connection with such use.

TI products are neither designed nor intended for use in automotive applications or environments unless the specific TI products are designated by TI as compliant with ISO/TS 16949 requirements. Buyers acknowledge and agree that, if they use any non-designated products in automotive applications, TI will not be responsible for any failure to meet such requirements.

Following are URLs where you can obtain information on other Texas Instruments products and application solutions:

### Products

Amplifiers	<a href="http://amplifier.ti.com">amplifier.ti.com</a>
Data Converters	<a href="http://dataconverter.ti.com">dataconverter.ti.com</a>
DSP	<a href="http://dsp.ti.com">dsp.ti.com</a>
Clocks and Timers	<a href="http://www.ti.com/clocks">www.ti.com/clocks</a>
Interface	<a href="http://interface.ti.com">interface.ti.com</a>
Logic	<a href="http://logic.ti.com">logic.ti.com</a>
Power Mgmt	<a href="http://power.ti.com">power.ti.com</a>
Microcontrollers	<a href="http://microcontroller.ti.com">microcontroller.ti.com</a>
RFID	<a href="http://www.ti-rfid.com">www.ti-rfid.com</a>
RF/IF and ZigBee® Solutions	<a href="http://www.ti.com/lprf">www.ti.com/lprf</a>

### Applications

Audio	<a href="http://www.ti.com/audio">www.ti.com/audio</a>
Automotive	<a href="http://www.ti.com/automotive">www.ti.com/automotive</a>
Broadband	<a href="http://www.ti.com/broadband">www.ti.com/broadband</a>
Digital Control	<a href="http://www.ti.com/digitalcontrol">www.ti.com/digitalcontrol</a>
Medical	<a href="http://www.ti.com/medical">www.ti.com/medical</a>
Military	<a href="http://www.ti.com/military">www.ti.com/military</a>
Optical Networking	<a href="http://www.ti.com/opticalnetwork">www.ti.com/opticalnetwork</a>
Security	<a href="http://www.ti.com/security">www.ti.com/security</a>
Telephony	<a href="http://www.ti.com/telephony">www.ti.com/telephony</a>
Video & Imaging	<a href="http://www.ti.com/video">www.ti.com/video</a>
Wireless	<a href="http://www.ti.com/wireless">www.ti.com/wireless</a>

Mailing Address: Texas Instruments, Post Office Box 655303, Dallas, Texas 75265  
Copyright © 2008, Texas Instruments Incorporated