

LM3402/HV 0.5-A Constant Current Buck Regulator for Driving High Power LEDs

1 Features

- Integrated 0.5-A N-channel MOSFET
- V_{IN} Range from 6 V to 42 V (LM3402)
- V_{IN} Range from 6 V to 75 V (LM3402HV)
- 500 mA Output Current Over Temperature
- Cycle-by-Cycle Current Limit
- No Control Loop Compensation Required
- Separate PWM Dimming and Low Power Shutdown
- Supports All Ceramic-Output Capacitors and Capacitor-Less Outputs
- Thermal Shutdown Protection
- VSSOP, SO PowerPAD™ Packages

2 Applications

- LED Drivers
- Constant Current Source
- Automotive Lighting
- General Illumination
- Industrial Lighting

3 Description

The LM3402/HV are monolithic switching regulators designed to deliver constant currents to high power LEDs. Ideal for automotive, industrial, and general lighting applications, they contain a high-side N-channel MOSFET switch with a current limit of 735 mA (typical) for step-down (Buck) regulators. Hysteretic control with controlled ON-time coupled with an external resistor allow the converter output voltage to adjust as needed to deliver a constant current to series and series - parallel connected arrays of LEDs of varying number and type, LED dimming by pulse width modulation (PWM), broken/open LED protection, low-power shutdown and thermal shutdown complete the feature set.

Device Information⁽¹⁾

PART NUMBER	PACKAGE	BODY SIZE (NOM)
LM3402/HV	VSSOP (8)	3.00 mm × 3.00 mm
	HSOP (8)	4.89 mm × 3.90 mm

(1) For all available packages, see the orderable addendum at the end of the data sheet.

Typical Application Diagram

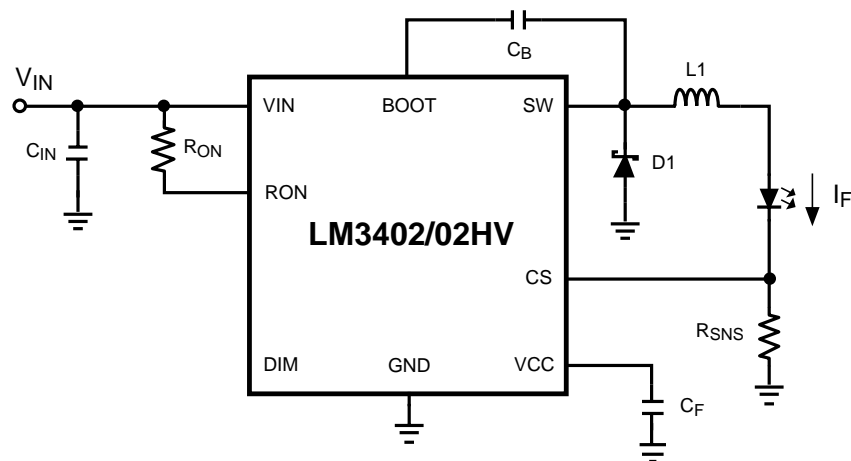

Table of Contents

1 Features 1 2 Applications 1 3 Description 1 4 Revision History 2 5 Pin Configuration and Functions 3 6 Specifications 4 6.1 Absolute Maximum Ratings 4 6.2 ESD Ratings 4 6.3 Recommended Operating Conditions 4 6.4 Thermal Information 5 6.5 Electrical Characteristics 5 6.6 Timing Requirements 6 6.7 Typical Characteristics 7 7 Detailed Description 10 7.1 Overview 10 7.2 Functional Block Diagram 10 7.3 Feature Description 10	7.4 Device Functional Modes 13 8 Application and Implementation 15 8.1 Application Information 15 8.2 Typical Application 23 9 Power Supply Recommendations 29 10 Layout 29 10.1 Layout Guidelines 29 10.2 Layout Example 30 11 Device and Documentation Support 31 11.1 Device Support 31 11.2 Related Links 31 11.3 Community Resources 31 11.4 Trademarks 31 11.5 Electrostatic Discharge Caution 31 11.6 Glossary 31 12 Mechanical, Packaging, and Orderable Information 31
--	---

4 Revision History

NOTE: Page numbers for previous revisions may differ from page numbers in the current version.

Changes from Revision E (April 2013) to Revision F	Page
<ul style="list-style-type: none"> • Added <i>ESD Ratings</i> and <i>Timing Requirements</i> tables, <i>Feature Description</i> section, <i>Device Functional Modes</i>, <i>Application and Implementation</i> section, <i>Power Supply Recommendations</i> section, <i>Layout</i> section, <i>Device and Documentation Support</i> section, and <i>Mechanical, Packaging, and Orderable Information</i> section 1 	1

Changes from Revision D (May 2013) to Revision E	Page
<ul style="list-style-type: none"> • Changed layout of National Data Sheet to TI format 1 	1

5 Pin Configuration and Functions



Pin Functions

PIN		I/O	DESCRIPTION
NO.	NAME		
1	SW	O	Switch pin. Connect this pin to the output inductor and Schottky diode.
2	BOOT	O	MOSFET drive bootstrap pin. Connect a 10-nF ceramic capacitor from this pin to SW.
3	DIM	I	Input for PWM dimming. Connect a logic-level PWM signal to this pin to enable and disable the power MOSFET and reduce the average light output of the LED array.
4	GND	—	Ground pin. Connect this pin to system ground.
5	CS	I	Current sense feedback pin. Set the current through the LED array by connecting a resistor from this pin to ground.
6	RON	I	ON-time control pin. A resistor connected from this pin to VIN sets the regulator controlled ON-time.
7	VCC	O	Output of the internal 7-V linear regulator. Bypass this pin to ground with a minimum 0.1- μ F ceramic capacitor with X5R or X7R dielectric.
8	VIN	I	Input voltage pin. Nominal operating input range for this pin is 6 V to 42 V (LM3402) or 6 V to 75 V (LM3402HV).
DAP		—	Thermal Pad. Connect to ground. Place 4-6 vias from DAP to bottom layer ground plane.

6 Specifications

6.1 Absolute Maximum Ratings

 over operating free-air temperature range (unless otherwise noted)⁽¹⁾⁽²⁾

		MIN	MAX	UNIT
VIN to GND	LM3402	-0.3	45	V
	LM3402HV	-0.3	76	
BOOT to GND	LM3402	-0.3	59	V
	LM3402HV	-0.3	90	
SW to GND	LM3402		-1.5	V
	LM3402HV	-1.5		
BOOT to VCC	LM3402	-0.3	45	V
	LM3402HV	-0.3	76	
BOOT to SW		-0.3	14	V
VCC to GND		-0.3	14	V
DIM to GND		-0.3	7	V
CS to GND		-0.3	7	V
RON to GND		-0.3	7	V
Soldering information	Lead temperature (soldering, 10 s)		260	°C
	Infrared/convection reflow (15 s)		235	°C
Junction temperature			150	°C
Storage temperature		-65	125	°C

- (1) Stresses beyond those listed under *Absolute Maximum Ratings* may cause permanent damage to the device. These are stress ratings only, which do not imply functional operation of the device at these or any other conditions beyond those indicated under *Recommended Operating Conditions*. Exposure to absolute-maximum-rated conditions for extended periods may affect device reliability.
- (2) If Military/Aerospace specified devices are required, contact the Texas Instruments Sales Office/ Distributors for availability and specifications.

6.2 ESD Ratings

			VALUE	UNIT
LM3402				
V _(ESD) Electrostatic discharge	Human-body model (HBM), per ANSI/ESDA/JEDEC JS-001 ⁽¹⁾		±2000	V
	Charged-device model (CDM), per JEDEC specification JESD22-C101 ⁽²⁾		±1000	
LM3402HV				
V _(ESD) Electrostatic discharge	Human-body model (HBM), per ANSI/ESDA/JEDEC JS-001 ⁽¹⁾		±2000	V
	Charged-device model (CDM), per JEDEC specification JESD22-C101 ⁽²⁾		±1000	

- (1) JEDEC document JEP155 states that 500-V HBM allows safe manufacturing with a standard ESD control process.
- (2) JEDEC document JEP157 states that 250-V CDM allows safe manufacturing with a standard ESD control process.

6.3 Recommended Operating Conditions

over operating free-air temperature range (unless otherwise noted)

		MIN	MAX	UNIT
V _{IN}	LM3402	6	42	V
	LM3402HV	6	75	
Junction temperature		-40	125	°C

6.4 Thermal Information

THERMAL METRIC ⁽¹⁾		LM3402, LM3402HV		UNIT
		DDA (HSOP)	DGK (VSSOP)	
		8 PINS	8 PINS	
R _{θJA}	Junction-to-ambient thermal resistance	45.6	154.4	°C/W
R _{θJC(top)}	Junction-to-case (top) thermal resistance	53.1	48.2	°C/W
R _{θJB}	Junction-to-board thermal resistance	25.8	74.2	°C/W
ψ _{JT}	Junction-to-top characterization parameter	7.6	4.3	°C/W
ψ _{JB}	Junction-to-board characterization parameter	25.7	72.9	°C/W
R _{θJC(bot)}	Junction-to-case (bottom) thermal resistance	3.2	N/A	°C/W

(1) For more information about traditional and new thermal metrics, see the *Semiconductor and IC Package Thermal Metrics* application report, [SPRA953](#).

6.5 Electrical Characteristics

V_{IN} = 24 V unless otherwise indicated. Typical values apply over –40°C ≤ T_J ≤ 125°C; minimum and maximum values apply over the full operating temperature range⁽¹⁾

PARAMETER	TEST CONDITIONS	MIN	TYP	MAX	UNIT	
REGULATION AND OVERVOLTAGE COMPARATORS						
V _{REF-REG}	CS Regulation Threshold	CS Decreasing, SW turns on	194	200	206	mV
V _{REF-OV}	CS Overvoltage Threshold	CS Increasing, SW turns off		300		mV
I _{CS}	CS Bias Current	CS = 0 V		0.1		μA
SHUTDOWN						
V _{SD-TH}	Shutdown Threshold	R _{ON} / SD Increasing	0.3	0.7	1.05	V
V _{SD-HYS}	Shutdown Hysteresis	R _{ON} / SD Decreasing		40		mV
OFF TIMER						
t _{OFF-MIN}	Minimum OFF-time	CS = 0 V		300		ns
INTERNAL REGULATOR						
V _{CC-REG}	V _{CC} Regulated Output		6.6	7	7.4	V
V _{IN-DO}	V _{IN} - V _{CC} Dropout	I _{CC} = 5 mA, 6 V < V _{IN} < 8 V		300		mV
V _{CC-BP-TH}	V _{CC} Bypass Threshold	V _{IN} Increasing		8.8		V
V _{CC-BP-HYS}	V _{CC} Bypass Hysteresis	V _{IN} Decreasing		225		mV
V _{CC-Z-6}	V _{CC} Output Impedance (0 mA < I _{CC} < 5 mA)	V _{IN} = 6 V		55		Ω
V _{CC-Z-8}		V _{IN} = 8 V		50		
V _{CC-Z-24}		V _{IN} = 24 V		0.4		
V _{CC-LIM}	V _{CC} Current Limit ⁽²⁾	V _{IN} = 24 V, V _{CC} = 0 V		16		mA
V _{CC-UV-TH}	V _{CC} Undervoltage Lock-out Threshold	V _{CC} Increasing		5.25		V
V _{CC-UV-HYS}	V _{CC} Undervoltage Lock-out Hysteresis	V _{CC} Decreasing		150		mV
V _{CC-UV-DLY}	V _{CC} Undervoltage Lock-out Filter Delay	100-mV Overdrive		3		μs
I _{IN-OP}	I _{IN} Operating Current	Non-switching, CS = 0 V		600	900	μA
I _{IN-SD}	I _{IN} Shutdown Current	R _{ON} / SD = 0 V		90	180	μA
CURRENT LIMIT						
I _{LIM}	Current Limit Threshold		530	735	940	mA
DIM COMPARATOR						
V _{IH}	Logic High	DIM Increasing	2.2			V
V _{IL}	Logic Low	DIM Decreasing			0.8	V
I _{DIM-PU}	DIM Pullup Current	DIM = 1.5 V		75		μA

(1) Typical specifications represent the most likely parametric norm at 25°C operation.

(2) V_{CC} provides self bias for the internal gate drive and control circuits. Device thermal limitations limit external loading.

Electrical Characteristics (continued)

$V_{IN} = 24\text{ V}$ unless otherwise indicated. Typical values apply over $-40^{\circ}\text{C} \leq T_J \leq 125^{\circ}\text{C}$; minimum and maximum values apply over the full operating temperature range ⁽¹⁾

PARAMETER		TEST CONDITIONS	MIN	TYP	MAX	UNIT
N-MOSFET AND DRIVER						
R_{DS-ON}	Buck Switch ON Resistance	$I_{SW} = 200\text{ mA}$, BOOT-SW = 6.3 V		0.7	1.5	Ω
$V_{DR-UVLO}$	BOOT Undervoltage Lockout Threshold	BOOT-SW Increasing	1.7	3	4	V
V_{DR-HYS}	BOOT Undervoltage Lockout Hysteresis	BOOT-SW Decreasing		400		mV
THERMAL SHUTDOWN						
T_{SD}	Thermal Shutdown Threshold			165		$^{\circ}\text{C}$
T_{SD-HYS}	Thermal Shutdown Hysteresis			25		$^{\circ}\text{C}$

6.6 Timing Requirements

			MIN	NOM	MAX	UNIT
t_{ON-1}	ON-time 1, $V_{IN} = 10\text{ V}$, $R_{ON} = 200\text{ k}\Omega$		2.1	2.75	3.4	μs
t_{ON-2}	ON-time 2, $V_{IN} = 40\text{ V}$, $R_{ON} = 200\text{ k}\Omega$	LM3402	490	650	810	ns
	ON-time 2, $V_{IN} = 70\text{ V}$, $R_{ON} = 200\text{ k}\Omega$	LM3402HV	290	380	470	

6.7 Typical Characteristics

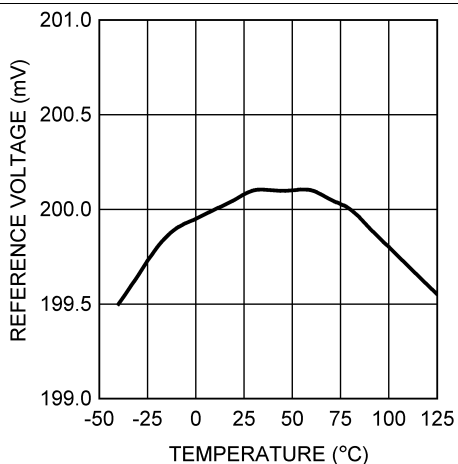

Figure 1. V_{REF} vs Temperature ($V_{IN} = 24$ V)

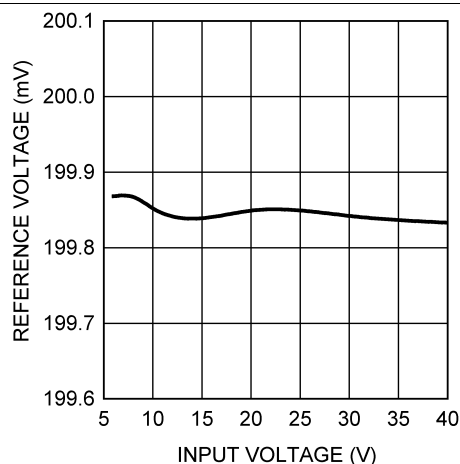

Figure 2. V_{REF} vs V_{IN} , LM3402 ($T_A = 25^\circ\text{C}$)

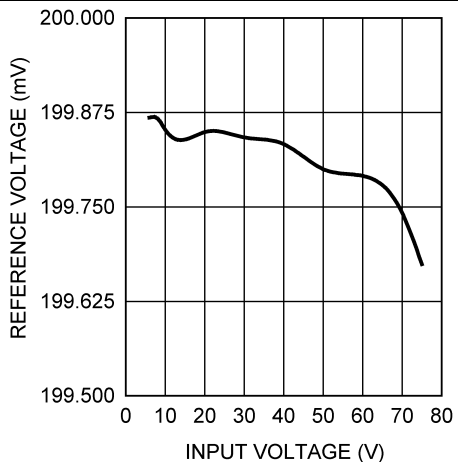

Figure 3. V_{REF} vs V_{IN} , LM3402HV ($T_A = 25^\circ\text{C}$)

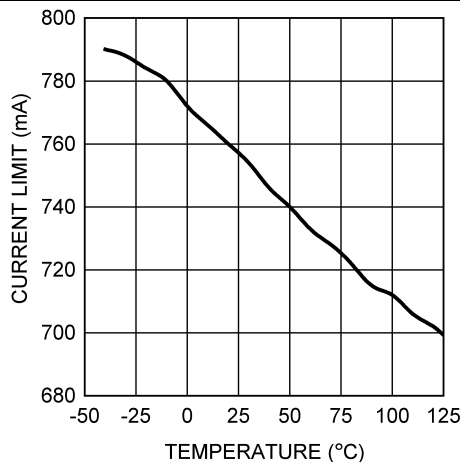

Figure 4. Current Limit vs Temperature ($V_{IN} = 24$ V)

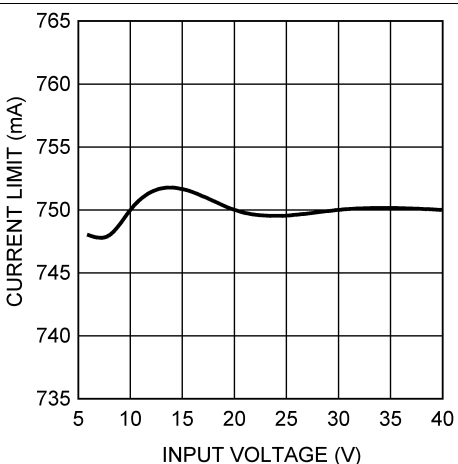

Figure 5. Current Limit vs V_{IN} , LM3402 ($T_A = 25^\circ\text{C}$)

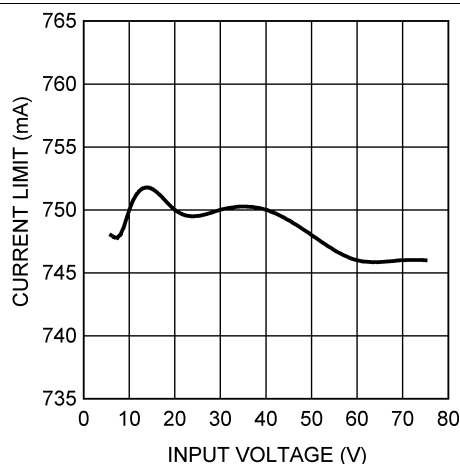

Figure 6. Current Limit vs V_{IN} , LM3402HV ($T_A = 25^\circ\text{C}$)

Typical Characteristics (continued)

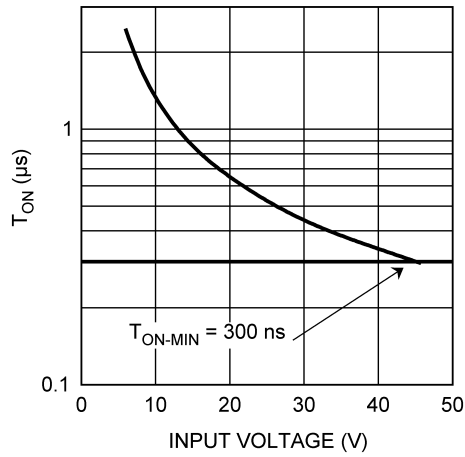

Figure 7. T_{ON} vs V_{IN} , $R_{ON} = 100\text{ k}\Omega$ ($T_A = 25^\circ\text{C}$)

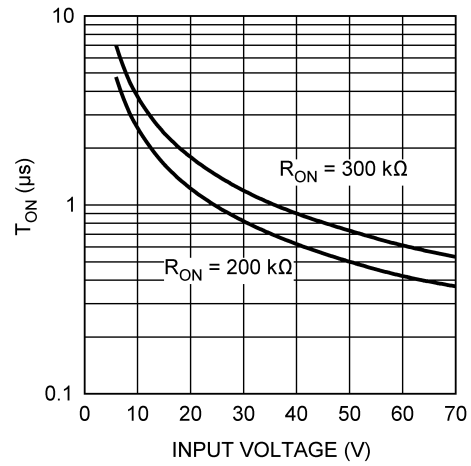

Figure 8. T_{ON} vs V_{IN} ($T_A = 25^\circ\text{C}$)

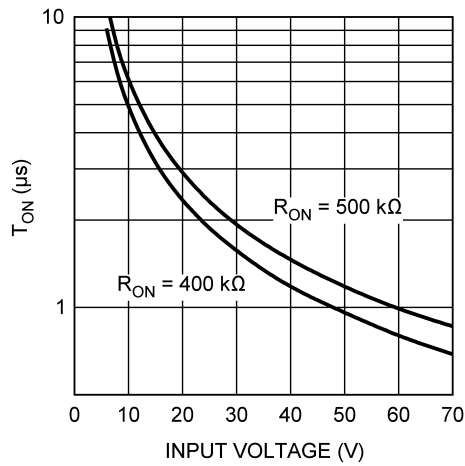

Figure 9. T_{ON} vs V_{IN} , ($T_A = 25^\circ\text{C}$)

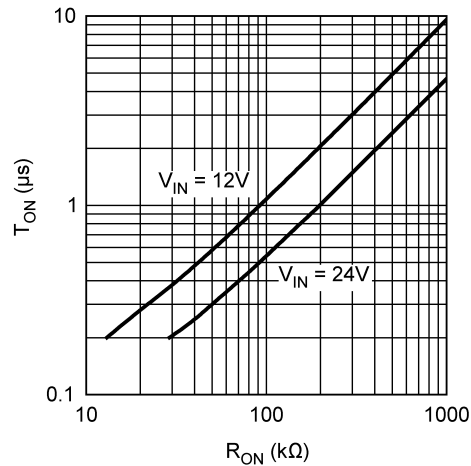

Figure 10. T_{ON} vs R_{ON} , LM3402 ($T_A = 25^\circ\text{C}$)

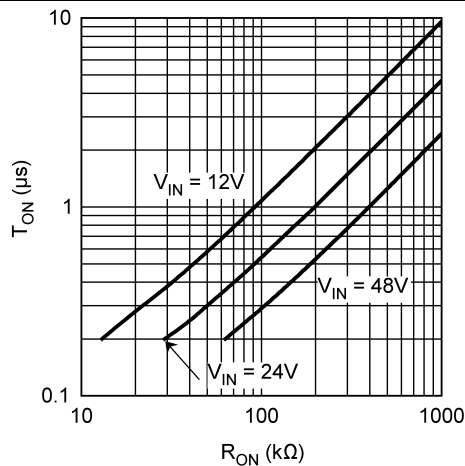

Figure 11. T_{ON} vs R_{ON} , LM3402HV ($T_A = 25^\circ\text{C}$)

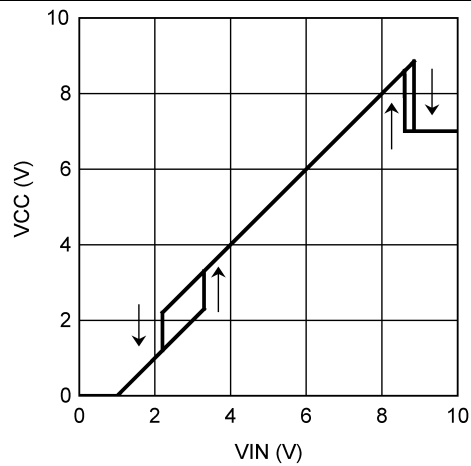

Figure 12. V_{CC} vs V_{IN} ($T_A = 25^\circ\text{C}$)

Typical Characteristics (continued)

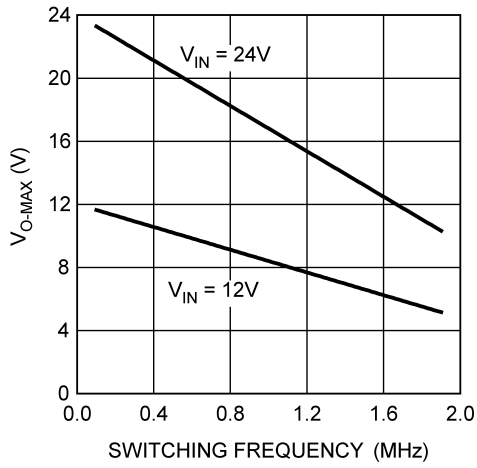

Figure 13. V_{O-MAX} vs f_{SW}, LM3402 (T_A = 25°C)

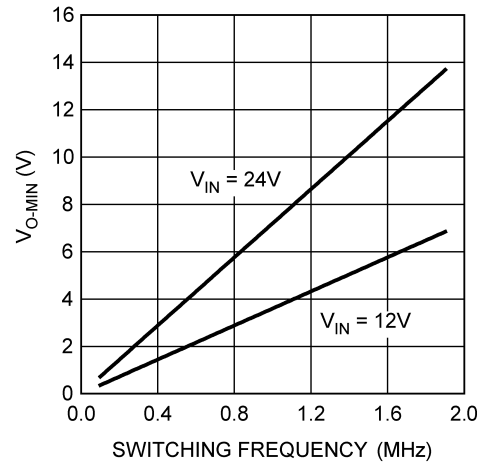

Figure 14. V_{O-MIN} vs f_{SW}, LM3402 (T_A = 25°C)

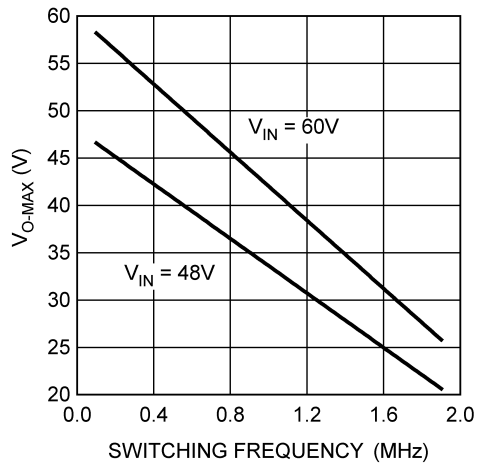

Figure 15. V_{O-MAX} vs f_{SW}, LM3402HV (T_A = 25°C)

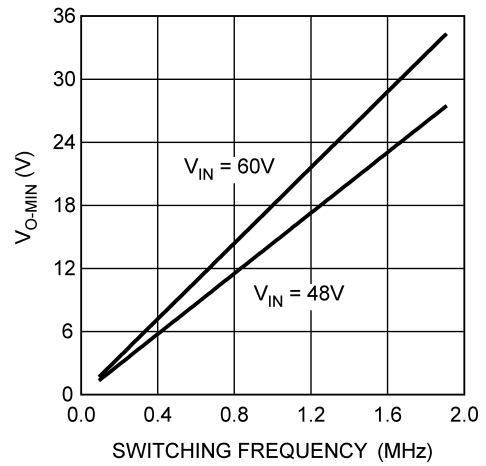

Figure 16. V_{O-MIN} vs f_{SW}, LM3402HV (T_A = 25°C)

7 Detailed Description

7.1 Overview

The LM3402 and LM3402HV are buck regulators with a wide input voltage range, low voltage reference, and a fast output enable/disable function. These features combine to make them ideal for use as a constant current source for LEDs with forward currents as high as 500 mA. The controlled ON-time (COT) architecture is a combination of hysteretic mode control and a one-shot ON-timer that varies inversely with input voltage. Hysteretic operation eliminates the need for small-signal control loop compensation. When the converter runs in continuous conduction mode (CCM) the controlled ON-time maintains a constant switching frequency over the range of input voltage. Fast transient response, PWM dimming, a low power shutdown mode, and simple output overvoltage protection round out the functions of the LM3402/HV.

7.2 Functional Block Diagram

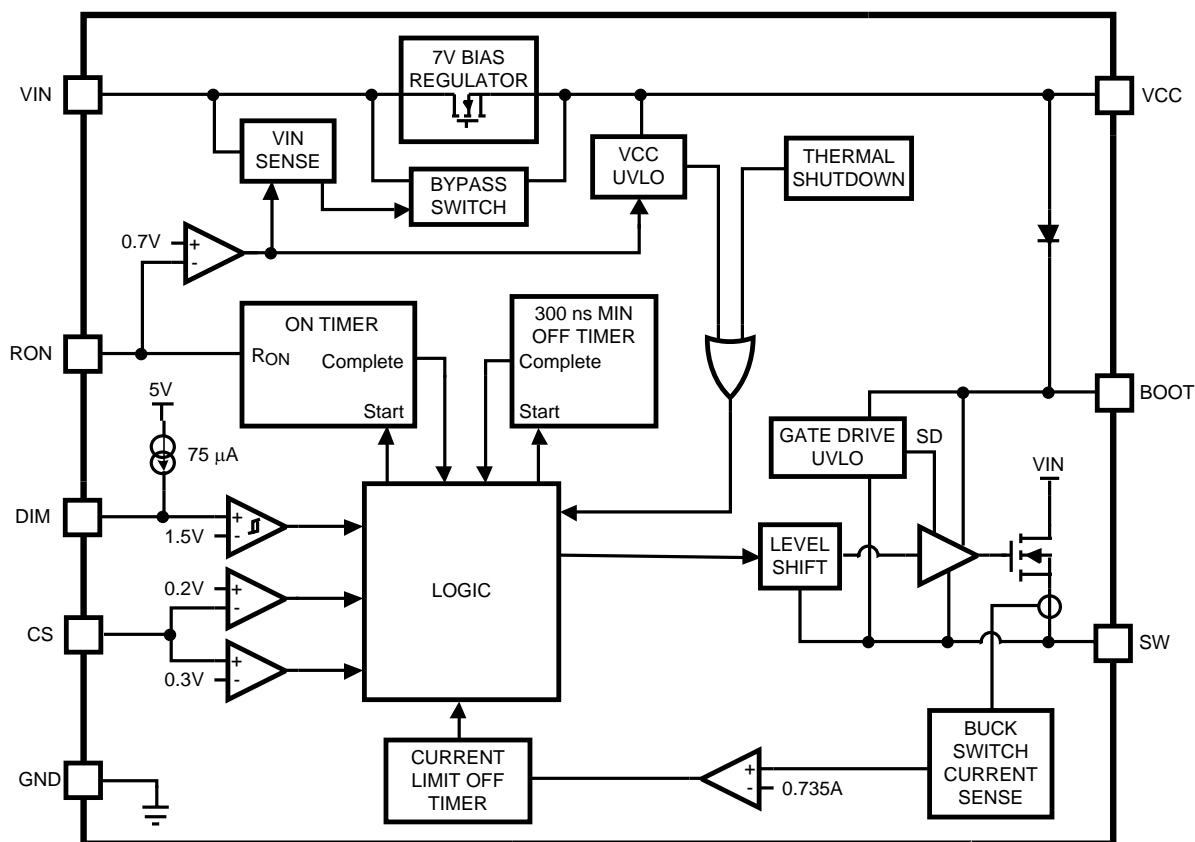

7.3 Feature Description

7.3.1 Controlled ON-time Overview

Figure 17 shows the feedback system used to control the current through an array of LEDs. A voltage signal, V_{SNS} , is created as the LED current flows through the current setting resistor, R_{SNS} , to ground. V_{SNS} is fed back to the CS pin, where it is compared against a 200-mV reference, V_{REF} . The ON-comparator turns on the power MOSFET when V_{SNS} falls below V_{REF} . The power MOSFET conducts for a controlled ON-time, t_{ON} , set by an external resistor, R_{ON} , and by the input voltage, V_{IN} . ON-time is governed using Equation 1.

$$t_{ON} = 1.34 \times 10^{-10} \times \frac{R_{ON}}{V_{IN}} \quad (1)$$

Feature Description (continued)

At the conclusion of t_{ON} the power MOSFET turns off for a minimum OFF-time, $t_{OFF-MIN}$, of 300 ns. Once $t_{OFF-MIN}$ is complete the CS comparator compares V_{SNS} and V_{REF} again, waiting to begin the next cycle.

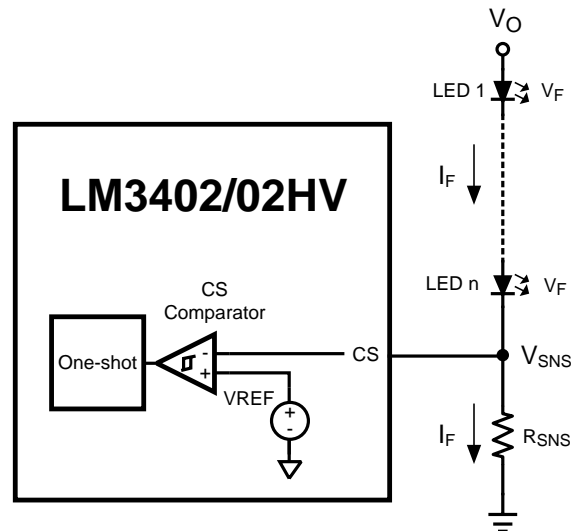

Figure 17. Comparator and One-Shot

The LM3402/HV regulators should be operated in continuous conduction mode (CCM), where inductor current stays positive throughout the switching cycle. During steady-state operation in the CCM, the converter maintains a constant switching frequency, which can be selected using [Equation 2](#).

$$f_{SW} = \frac{V_O}{1.34 \times 10^{-10} \times R_{ON}}$$

$$V_O = n \times V_F + 200 \text{ mV} \quad (2)$$

$$V_F = \text{forward voltage of each LED, } n = \text{number of LEDs in series} \quad (3)$$

7.3.2 Average LED Current Accuracy

The COT architecture regulates the valley of ΔV_{SNS} , the AC portion of V_{SNS} . To determine the average LED current (which is also the average inductor current) the valley inductor current is calculated using [Equation 4](#).

$$I_{L-MIN} = \frac{0.2}{R_{SNS}} - \frac{V_O \times t_{SNS}}{L} \quad (4)$$

In [Equation 4](#) t_{SNS} represents the propagation delay of the CS comparator, and is approximately 220 ns. The average inductor/LED current is equal to I_{L-MIN} plus one-half of the inductor current ripple, Δi_L :

$$I_F = I_L = I_{L-MIN} + \Delta i_L / 2 \quad (5)$$

Detailed information for the calculation of Δi_L is given in the [Application and Implementation](#) section.

7.3.3 Maximum Output Voltage

The 300 ns minimum off-time limits on the maximum duty cycle of the converter, D_{MAX} , and in turn, the maximum output voltage $V_{O(MAX)}$ is determined by [Equation 6](#):

$$D_{MAX} = \frac{t_{ON}}{t_{ON} + t_{OFF-MIN}}$$

$$V_{O(max)} = D_{MAX} \times V_{IN} \quad (6)$$

Feature Description (continued)

The maximum number of LEDs, n_{MAX} , that can be placed in a single series string is governed by $V_{O(MAX)}$ and the maximum forward voltage of the LEDs used, $V_{F(MAX)}$, using the expression:

$$n_{MAX} = \frac{V_{O(max)} - 200 \text{ mV}}{V_{F(MAX)}} \quad (7)$$

At low switching frequency the maximum duty cycle and output voltage are higher, allowing the LM3402/HV to regulate output voltages that are nearly equal to input voltage. The following equation relates switching frequency to maximum output voltage.

$$V_{O(MAX)} = V_{IN} \times \frac{T_{SW} - 300 \text{ ns}}{T_{SW}}$$

$$T_{SW} = 1/f_{SW} \quad (8)$$

7.3.4 Minimum Output Voltage

The minimum recommended ON-time for the LM3402/HV is 300 ns. This lower limit for t_{ON} determines the minimum duty cycle and output voltage that can be regulated based on input voltage and switching frequency. The relationship is determined by the following equation:

$$V_{O(MIN)} = V_{IN} \times \frac{300 \text{ ns}}{T_{SW}} \quad (9)$$

7.3.5 High Voltage Bias Regulator

The LM3402/HV contains an internal linear regulator with a 7-V output, connected between the VIN and the VCC pins. The VCC pin should be bypassed to the GND pin with a 0.1- μ F ceramic capacitor connected as close as possible to the pins of the device. VCC tracks VIN until VIN reaches 8.8 V (typical) and then regulates at 7 V as VIN increases. Operation begins when VCC crosses 5.25 V.

7.3.6 Internal MOSFET and Driver

The LM3402/HV features an internal power MOSFET as well as a floating driver connected from the SW pin to the BOOT pin. Both rise time and fall time are 20 ns each (typical) and the approximate gate charge is 3 nC. The high-side rail for the driver circuitry uses a bootstrap circuit consisting of an internal high-voltage diode and an external 10 nF capacitor, C_B . V_{CC} charges C_B through the internal diode while the power MOSFET is off. When the MOSFET turns on, the internal diode reverse biases. This creates a floating supply equal to the V_{CC} voltage minus the diode drop to drive the MOSFET when its source voltage is equal to V_{IN} .

7.3.7 Fast Shutdown for PWM Dimming

The DIM pin of the LM3402/HV is a TTL logic compatible input for low-frequency PWM dimming of the LED. A logic low (less than 0.8V) at DIM will disable the internal MOSFET and shut off the current flow to the LED array. While the DIM pin is in a logic low state the support circuitry (driver, bandgap, VCC) remains active to minimize the time needed to turn the LED array back on when the DIM pin sees a logic high (above 2.2 V). A 75 μ A (typical) pullup current ensures that the LM3402/HV is on when DIM pin is open circuited, eliminating the need for a pullup resistor. Dimming frequency, f_{DIM} , and duty cycle, D_{DIM} , are limited by the LED current rise time and fall time and the delay from activation of the DIM pin to the response of the internal power MOSFET. In general, f_{DIM} should be at least one order of magnitude lower than the steady state switching frequency to prevent aliasing.

7.3.8 Peak Current Limit

The current limit comparator of the LM3402/HV will engage whenever the power MOSFET current (equal to the inductor current while the MOSFET is on) exceeds 735 mA (typical). The power MOSFET is disabled for a cool-down time that is 10x the steady-state ON-time. At the conclusion of this cool-down time the system re-starts. If the current limit condition persists the cycle of cool-down time and restarting will continue, creating a low-power hiccup mode, minimizing thermal stress on the LM3402/HV and the external circuit components.

Feature Description (continued)

7.3.9 Overvoltage and Overcurrent Comparator

The CS pin includes an output overvoltage/overcurrent comparator that will disable the power MOSFET whenever V_{SNS} exceeds 300 mV. This threshold provides a hard limit for the output current. Output current overshoot is limited to $300 \text{ mV} / R_{SNS}$ by this comparator during transients.

The OVP/OCP comparator can also be used to prevent the output voltage from rising to $V_{O(MAX)}$ in the event of an output open-circuit. This is the most common failure mode for LEDs, due to breaking of the bond wires. In a current regulator an output open circuit causes V_{SNS} to fall to zero, commanding maximum duty cycle. [Figure 18](#) shows a method using a Zener diode, Z1, and Zener limiting resistor, R_Z , to limit output voltage to the reverse breakdown voltage of Z1 plus 200 mV. The Zener diode reverse breakdown voltage, V_Z , must be greater than the maximum combined V_F of all LEDs in the array. The maximum recommended value for R_Z is 1 k Ω .

As discussed in the Maximum Output Voltage section, there is a limit to how high V_O can rise during an output open-circuit that is always less than V_{IN} . If no output capacitor is used, the output stage of the LM3402/HV is capable of withstanding $V_{O(MAX)}$ indefinitely, however the voltage at the output end of the inductor will oscillate and can go above V_{IN} or less than 0 V. A small (typically 10 nF) capacitor across the LED array dampens this oscillation. For circuits that use an output capacitor, the system can still withstand $V_{O(MAX)}$ indefinitely as long as C_O is rated to handle V_{IN} . The high current paths are blocked in output open-circuit and the risk of thermal stress is minimal, hence the user may opt to allow the output voltage to rise in the case of an open-circuit LED failure.

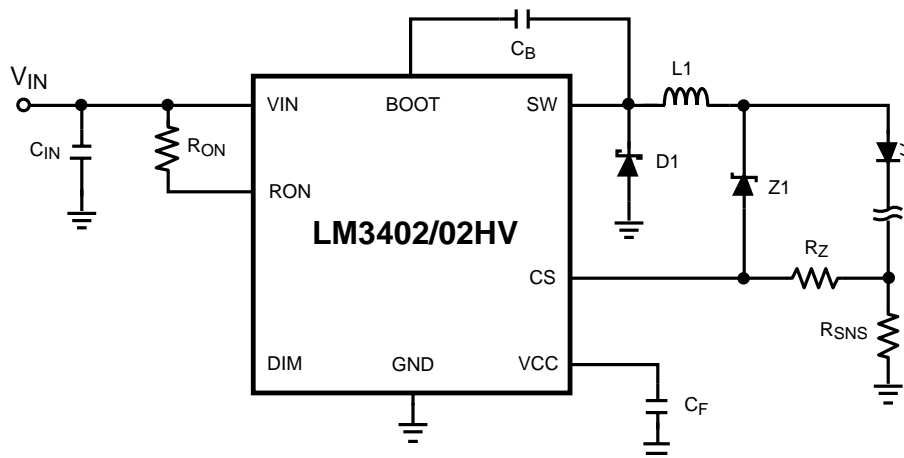
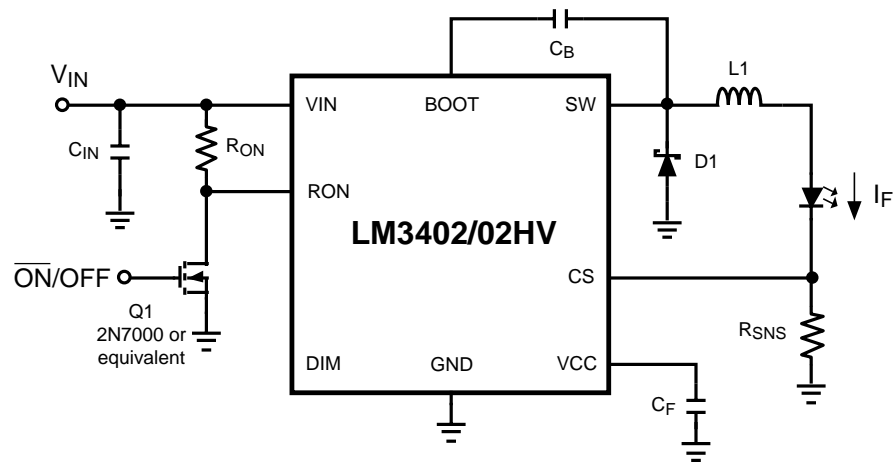

Figure 18. Output Open Circuit Protection

7.4 Device Functional Modes

7.4.1 Low Power Shutdown

The LM3402/HV can be switched to a low power state ($I_{IN-SD} = 90 \mu\text{A}$) by grounding the RON pin with a signal-level MOSFET as shown in [Figure 19](#). Low power MOSFETs like the 2N7000, 2N3904, or equivalent are recommended devices for putting the LM3402/HV into low power shutdown. Logic gates can also be used to shut down the LM3402/HV as long as the logic low voltage is below the over temperature minimum threshold of 0.3V. Noise filter circuitry on the RON pin can cause a few pulses with a longer ON-time than normal after RON is grounded or released. In these cases the OVP/OCP comparator will ensure that the peak inductor or LED current does not exceed $300 \text{ mV} / R_{SNS}$.

Device Functional Modes (continued)

Figure 19. Low Power Shutdown
7.4.2 Thermal Shutdown

Internal thermal shutdown circuitry is provided to protect the device in the event that the maximum junction temperature is exceeded. The threshold for thermal shutdown is 165°C with a 25°C hysteresis (both values typical). During thermal shutdown the MOSFET and driver are disabled.

8 Application and Implementation

NOTE

Information in the following applications sections is not part of the TI component specification, and TI does not warrant its accuracy or completeness. TI's customers are responsible for determining suitability of components for their purposes. Customers should validate and test their design implementation to confirm system functionality.

8.1 Application Information

8.1.1 Switching Frequency

Switching frequency is selected based on the tradeoffs between efficiency (better at low frequency), solution size/cost (smaller at high frequency), and the range of output voltage that can be regulated (wider at lower frequency.) Many applications place limits on switching frequency due to EMI sensitivity. The ON-time of the LM3402/HV can be programmed for switching frequencies ranging from the 10's of kHz to over 1 MHz. The maximum switching frequency is limited only by the minimum ON-time requirement.

8.1.2 LED Ripple Current

Selection of the ripple current, Δi_F , through the LED array is analogous to the selection of output ripple voltage in a standard voltage regulator. Where the output ripple in a voltage regulator is commonly $\pm 1\%$ to $\pm 5\%$ of the DC output voltage, LED manufacturers generally recommend values for Δi_F ranging from $\pm 5\%$ to $\pm 20\%$ of I_F . Higher LED ripple current allows the use of smaller inductors, smaller output capacitors, or no output capacitors at all. The advantages of higher ripple current are reduction in the solution size and cost. Lower ripple current requires more output inductance, higher switching frequency, or additional output capacitance. The advantages of lower ripple current are a reduction in heating in the LED itself and greater range of the average LED current before the current limit of the LED or the driving circuitry is reached.

8.1.3 Buck Converters Without Output Capacitors

The buck converter is unique among non-isolated topologies because of the direct connection of the inductor to the load during the entire switching cycle. By definition an inductor will control the rate of change of current that flows through it, and this control overcurrent ripple forms the basis for component selection in both voltage regulators and current regulators. A current regulator such as the LED driver for which the LM3402/HV was designed focuses on the control of the current through the load, not the voltage across it. A constant current regulator is free of load current transients, and has no need of output capacitance to supply the load and maintain output voltage. Referring to the [Typical Application Diagram](#), the inductor and LED can form a single series chain, sharing the same current. When no output capacitor is used, the same equations that govern inductor ripple current, Δi_L , also apply to the LED ripple current, Δi_F . For a controlled ON-time converter such as LM3402/HV the ripple current is described by the following expression:

$$\Delta i_L = \Delta i_F = \frac{V_{IN} - V_O}{L} t_{ON} \quad (10)$$

A minimum ripple voltage of 25 mV is recommended at the CS pin to provide good signal-to-noise ratio (SNR). The CS pin ripple voltage, ΔV_{SNS} , is described by the following:

$$\Delta V_{SNS} = \Delta i_F \times R_{SNS} \quad (11)$$

8.1.4 Buck Converters With Output Capacitors

A capacitor placed in parallel with the LED or array of LEDs can be used to reduce the LED current ripple while keeping the same average current through both the inductor and the LED array. This technique is demonstrated in [Typical Application](#). With this topology the output inductance can be lowered, making the magnetics smaller and less expensive. Alternatively, the circuit could be run at lower frequency but keep the same inductor value, improving the efficiency and expanding the range of output voltage that can be regulated. Both the peak current limit and the OVP/OCP comparator still monitor peak inductor current, placing a limit on how large Δi_L can be even if Δi_F is made very small. A parallel output capacitor is also useful in applications where the inductor or input voltage tolerance is poor. Adding a capacitor that reduces Δi_F to well below the target provides headroom for changes in inductance or V_{IN} that might otherwise push the peak LED ripple current too high.

Application Information (continued)

Figure 20 shows the equivalent impedances presented to the inductor current ripple when an output capacitor, C_O , and its equivalent series resistance (ESR) are placed in parallel with the LED array. The entire inductor ripple current flows through R_{SNS} to provide the required 25 mV of ripple voltage for proper operation of the CS comparator.

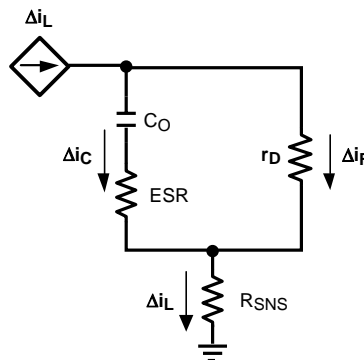

Figure 20. LED and C_O Ripple Current

To calculate the respective ripple currents the LED array is represented as a dynamic resistance, r_D . LED dynamic resistance is not always specified on the manufacturer's data sheet, but it can be calculated as the inverse slope of the LED's V_F vs. I_F curve. Dividing V_F by I_F will give an incorrect value that is 5x to 10x too high. Total dynamic resistance for a string of n LEDs connected in series can be calculated as the r_D of one device multiplied by n . Inductor ripple current is still calculated with the expression from Buck Regulators without Output Capacitors. The following equations can then be used to estimate Δi_F when using a parallel capacitor:

$$\Delta i_F = \frac{\Delta i_L}{1 + \frac{r_D}{Z_C}}$$

$$Z_C = ESR + \frac{1}{2\pi \times f_{SW} \times C_O}$$
(12)

The calculation for Z_C assumes that the shape of the inductor ripple current is approximately sinusoidal.

Small values of C_O that do not significantly reduce Δi_F can also be used to control EMI generated by the switching action of the LM3402/HV. EMI reduction becomes more important as the length of the connections between the LED and the rest of the circuit increase.

8.1.5 Input Capacitors

Input capacitors at the VIN pin of the LM3402/HV are selected using requirements for minimum capacitance and rms ripple current. The input capacitors supply pulses of current approximately equal to I_F while the power MOSFET is on, and are charged up by the input voltage while the power MOSFET is off. Switching converters such as the LM3402/HV have a negative input impedance due to the decrease in input current as input voltage increases. This inverse proportionality of input current to input voltage can cause oscillations (sometimes called 'power supply interaction') if the magnitude of the negative input impedance is greater than the input filter impedance. Minimum capacitance can be selected by comparing the input impedance to the converter's negative resistance; however this requires accurate calculation of the input voltage source inductance and resistance, quantities which can be difficult to determine. An alternative method to select the minimum input capacitance, $C_{IN(MIN)}$, is to select the maximum voltage ripple which can be tolerated. This value, $\Delta V_{IN(MAX)}$, is equal to the change in voltage across C_{IN} during the converter ON-time, when C_{IN} supplies the load current. $C_{IN(MIN)}$ can be selected with the following:

$$C_{IN(MIN)} = \frac{I_F \times t_{ON}}{\Delta V_{IN(MAX)}}$$
(13)

Application Information (continued)

A good starting point for selection of C_{IN} is to use an input voltage ripple of 5% to 10% of V_{IN} . A minimum input capacitance of $2 \times$ the $C_{IN(MIN)}$ value is recommended for all LM3402/HV circuits. To determine the rms current rating, the following formula can be used:

$$I_{IN(rms)} = I_F \times \sqrt{D(1 - D)} \quad (14)$$

Ceramic capacitors are the best choice for the input to the LM3402/HV due to their high ripple current rating, low ESR, low cost, and small size compared to other types. When selecting a ceramic capacitor, special attention must be paid to the operating conditions of the application. Ceramic capacitors can lose one-half or more of their capacitance at their rated DC voltage bias and also lose capacitance with extremes in temperature. A DC voltage rating equal to twice the expected maximum input voltage is recommended. In addition, the minimum quality dielectric which is suitable for switching power supply inputs is X5R, while X7R or better is preferred.

8.1.6 Recirculating Diode

The LM3402/HV is a non-synchronous buck regulator that requires a recirculating diode D1 (see the Typical Application circuit) to carrying the inductor current during the MOSFET off-time. The most efficient choice for D1 is a Schottky diode due to low forward drop and near-zero reverse recovery time. D1 must be rated to handle the maximum input voltage plus any switching node ringing when the MOSFET is on. In practice all switching converters have some ringing at the switching node due to the diode parasitic capacitance and the lead inductance. D1 must also be rated to handle the average current, I_D , calculated as:

$$I_D = (1 - D) \times I_F \quad (15)$$

This calculation should be done at the maximum expected input voltage. The overall converter efficiency becomes more dependent on the selection of D1 at low duty cycles, where the recirculating diode carries the load current for an increasing percentage of the time. This power dissipation can be calculated by checking the typical diode forward voltage, V_D , from the I-V curve on the product data sheet and then multiplying it by I_D . Diode data sheets will also provide a typical junction-to-ambient thermal resistance, θ_{JA} , which can be used to estimate the operating die temperature of the Schottky. Multiplying the power dissipation ($P_D = I_D \times V_D$) by θ_{JA} gives the temperature rise. The diode case size can then be selected to maintain the Schottky diode temperature below the operational maximum.

8.1.7 LED Current During DIM Mode

The LM3402 contains high speed MOSFET gate drive circuitry that switches the main internal power MOSFET between ON and OFF states. This circuitry uses current derived from the VCC regulator to charge the MOSFET during turnon, then dumps current from the MOSFET gate to the source (the SW pin) during turnoff. As shown in the block diagram, the MOSFET drive circuitry contains a gate drive undervoltage lockout (UVLO) circuit that ensures the MOSFET remains off when there is inadequate VCC voltage for proper operation of the driver. This watchdog circuitry is always running including during DIM and shutdown modes, and supplies a small amount of current from VCC to SW. Because the SW pin is connected directly to the LEDs through the buck inductor, this current returns to ground through the LEDs. The amount of current sourced is a function of the SW voltage, as shown in [Figure 21](#).

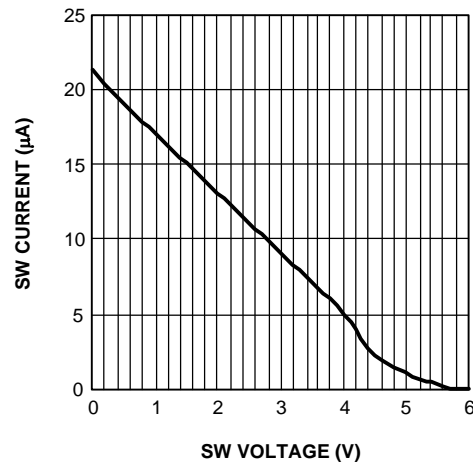
Application Information (continued)

Figure 21. LED Current From SW Pin

Though most power LEDs are designed to run at several hundred milliamps, some can be seen to glow with a faint light at extremely low current levels, as low as a couple microamps in some instances. In lab testing, the forward voltage was found to be approximately 2 V for LEDs that exhibited visible light at these low current levels. For LEDs that did not show light emission at very low current levels, the forward voltage was found to be around 900 mV. It is important to remember that the forward voltage is also temperature dependent, decreasing at higher temperatures. Consequently, with a maximum V_{CC} voltage of 7.4 V, current will be observed in the LEDs if the total stack voltage is less than about 6 V at a forward current of several microamps. No current is observed if the stack voltage is above 6 V, as shown in [Figure 21](#). The need for absolute darkness during DIM mode is also application dependent. It will not affect regular PWM dimming operation.

The fix for this issue is extremely simple. Place a resistor from the SW pin to ground according to [Table 1](#).

Table 1. LED Resistor Values

NUMBER OF LEDs	RESISTOR VALUE (kΩ)
1	20
2	50
3	90
4	150
5	200
>5	300

The luminaire designer should ensure that the suggested resistor is effective in eliminating the off-state light output. A combination of calculations based on LED manufacturer data and lab measurements over temperature will ensure the best design.

8.1.8 Transient Protection Considerations

Considerations must be made when external sources, loads or connections are made to the switching converter circuit due to the possibility of Electrostatic Discharge (ESD) or Electric Over Stress (EOS) events occurring and damaging the integrated circuit (IC) device. All IC device pins contain Zener based clamping structures that are meant to clamp ESD. ESD events are very low energy events, typically less than 5 μJ (microjoules). Any event that transfers more energy than this may damage the ESD structure. Damage is typically represented as a short from the pin to ground as the extreme localized heat of the ESD / EOS event causes the aluminum metal on the chip to melt, causing the short. This situation is common to all integrated circuits and not just unique to the LM340X device.

8.1.8.1 CS Pin Protection

When hot swapping in a load (for example, test points, load boards, LED stack), any residual charge on the load will be immediately transferred through the output capacitor to the CS pin, which is then damaged as shown in Figure 22 below. The EOS event due to the residual charge from the load is represented as $V_{\text{TRANSIENT}}$.

From measurements, we know that the 8V ESD structure on the CS pin can typically withstand 25mA of direct current (DC). Adding a 1-kΩ resistor in series with the CS pin, shown in Figure 23, results in the majority of the transient energy to pass through the discrete sense resistor rather than the device. The series resistor limits the peak current that can flow during a transient event, thus protecting the CS pin. With the 1-kΩ resistor shown, a 33-V, 49-A transient on the LED return connector terminal could be absorbed as calculated by:

$$V = 25 \text{ mA} \times 1 \text{ k}\Omega + 8 \text{ V} = 33 \text{ V} \tag{16}$$

$$I = 33 \text{ V} / 0.67 \Omega = 49 \text{ A} \tag{17}$$

This is an extremely high energy event, so the protection measures previously described should be adequate to solve this issue.

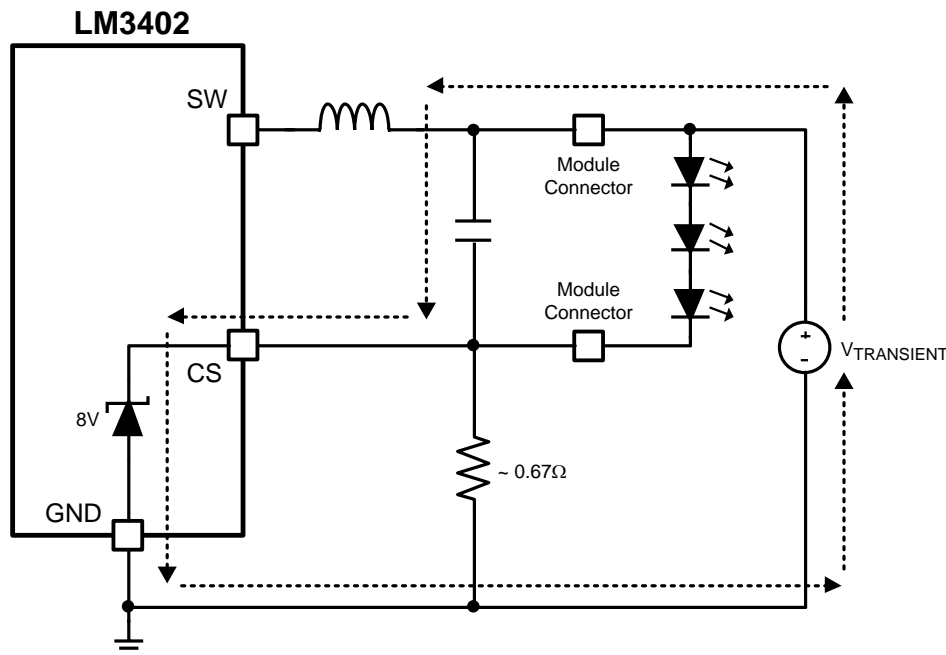

Figure 22. CS Pin, Transient Path

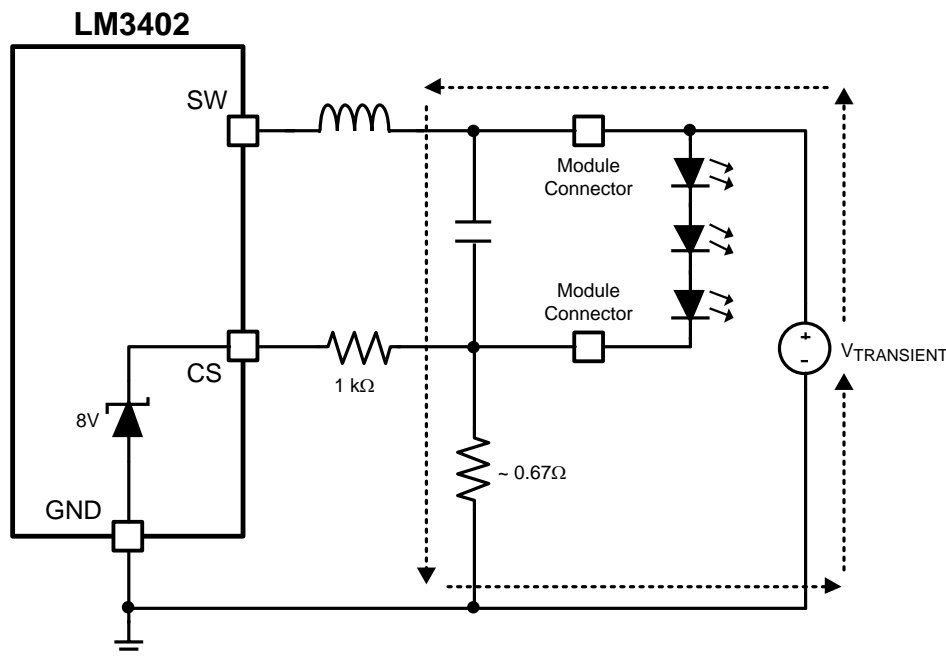

Figure 23. CS Pin, Transient Path With Protection

Adding a resistor in series with the CS pin causes the observed output LED current to shift very slightly. The reason for this is twofold: (1) the CS pin has about 20 pF of inherent capacitance inside it which causes a slight delay (20 ns for a 1-k Ω series resistor), and (2) the comparator that is watching the voltage at the CS pin uses a pnp bipolar transistor at its input. The base current of this pnp transistor is approximately 100 nA, which will cause a 0.1-mV change in the 200-mV threshold. These are both very minor changes and are well understood. The shift in current can either be neglected or taken into consideration by changing the current sense resistance slightly.

8.1.8.2 CS Pin Protection With OVP

When designing output overvoltage protection into the switching converter circuit using a Zener diode, transient protection on the CS pin requires additional consideration. As shown in [Figure 24](#), adding a Zener diode from the output to the CS pin (with the series resistor) for output overvoltage protection will now again allow the transient energy to be passed through the CS pin's ESD structure thereby damaging it.

Adding an additional series resistor to the CS pin as shown in [Figure 25](#) will result in the majority of the transient energy to pass through the sense resistor, thereby protecting the LM340X device.

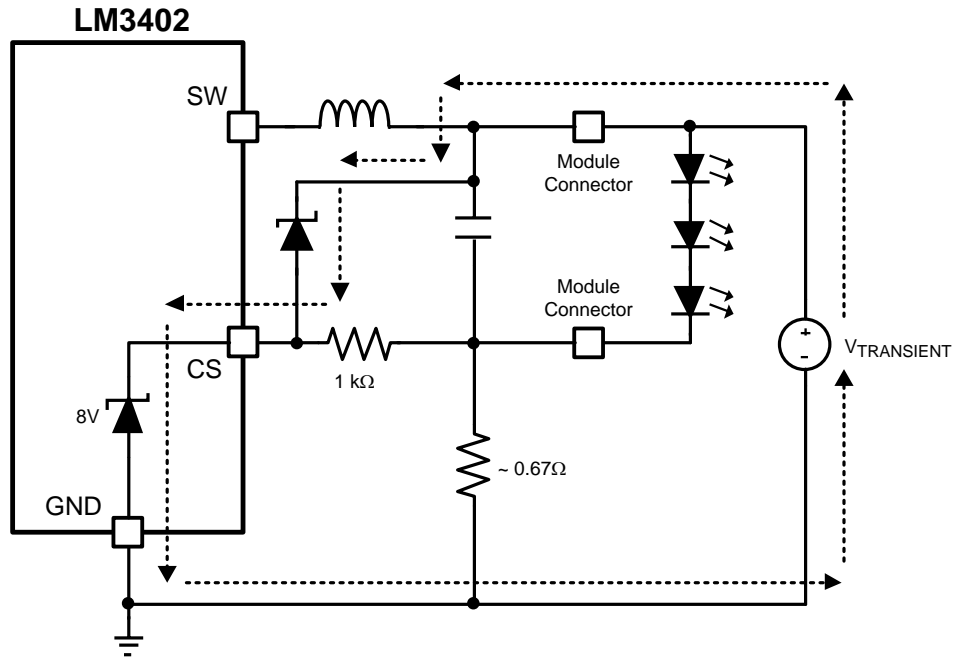

Figure 24. CS Pin With OVP, Transient Path

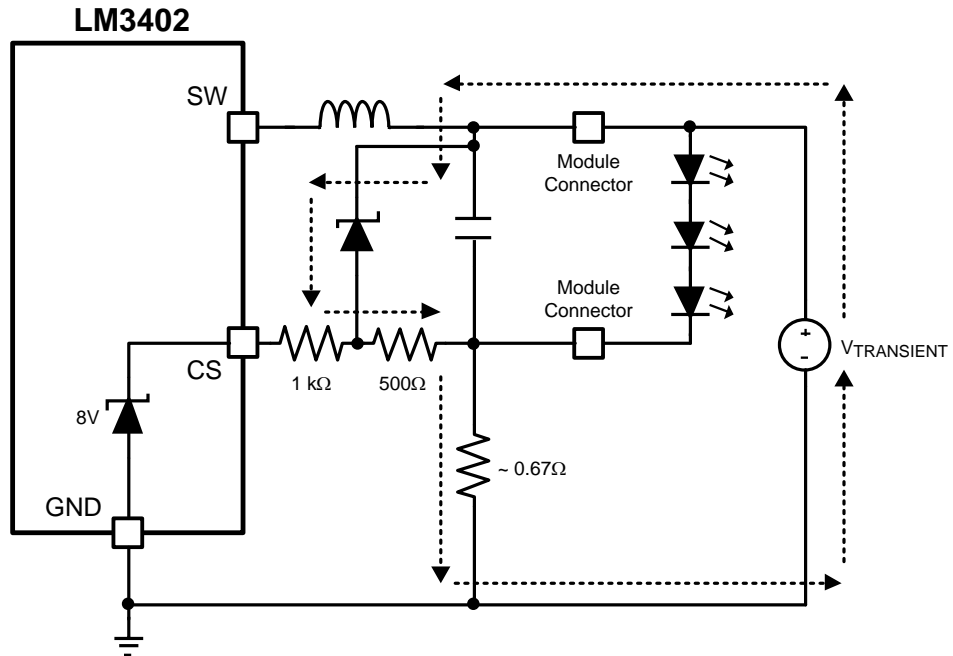

Figure 25. CS Pin With OVP, Transient Path with Protection

8.1.8.3 VIN Pin Protection

The VIN pin also has an ESD structure from the pin to GND with a breakdown voltage of approximately 80 V. Any transient that exceeds this voltage may damage the device. Although transient absorption is usually present at the front end of a switching converter circuit, damage to the VIN pin can still occur.

When V_{IN} is hot swapped in, the current that rushes in to charge C_{IN} up to the V_{IN} value also charges (energizes) the circuit board trace inductance as shown in Figure 26. The excited trace inductance then resonates with the input capacitance (similar to an under-damped LC tank circuit) and causes voltages at the V_{IN} pin to rise well in excess of both V_{IN} and the voltage at the module input connector as clamped by the input TVS. If the resonating voltage at the V_{IN} pin exceeds the 80-V breakdown voltage of the ESD structure, the ESD structure will activate and then snap-back to a lower voltage due to its inherent design. If this lower snap-back voltage is less than the applied nominal V_{IN} voltage, then significant current will flow through the ESD structure resulting in the device being damaged.

An additional TVS or small Zener diode should be placed as close as possible to the V_{IN} pins of each device on the board, in parallel with the input capacitor as shown in Figure 27. A minor amount of series resistance in the input line would also help, but would lower overall conversion efficiency. For this reason, NTC resistors are often used as inrush limiters instead.

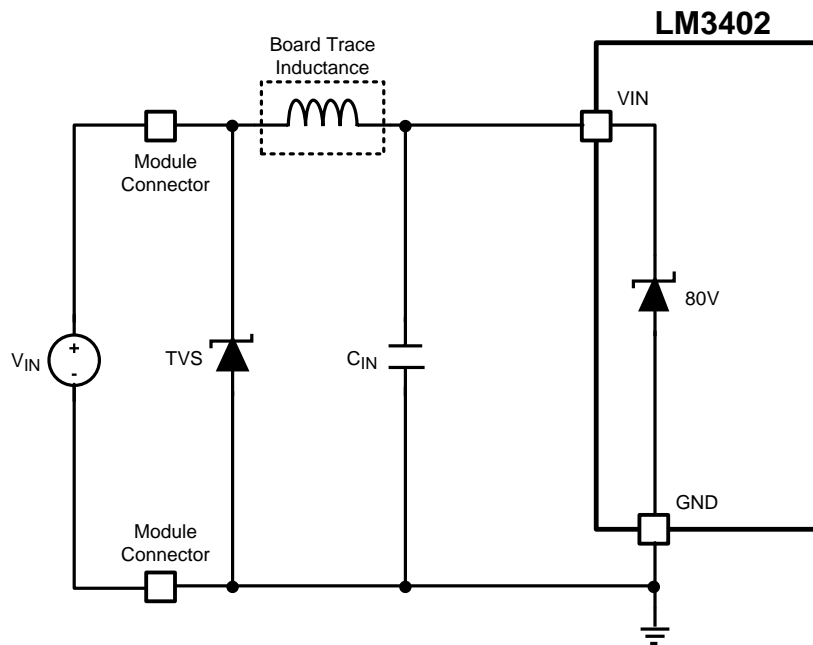

Figure 26. V_{IN} Pin With Typical Input Protection

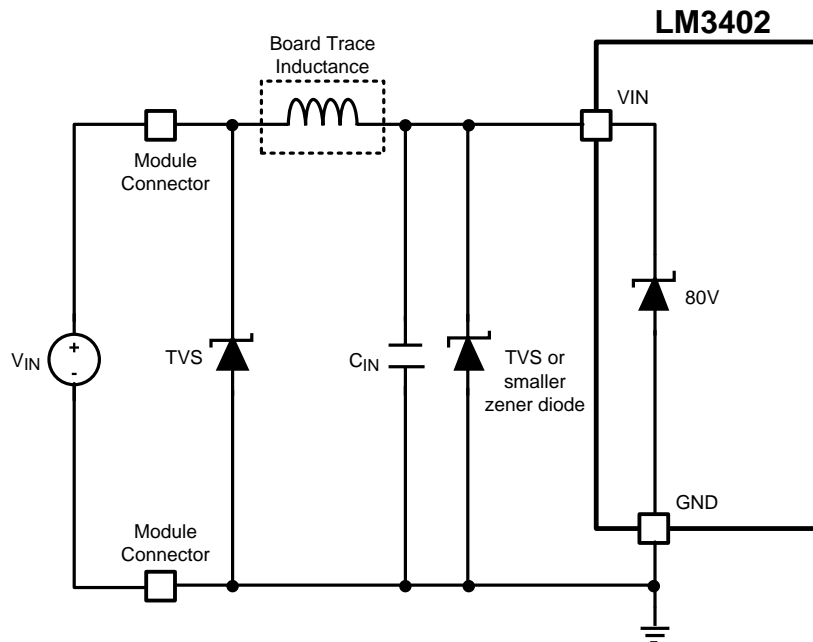

Figure 27. VIN Pin With Additional Input Protection

8.1.8.4 General Comments Regarding Other Pins

Any pin that goes off-board through a connector should have series resistance of at least 1 k Ω to 10 k Ω in series with it to protect it from ESD or other transients. These series resistors limit the peak current that can flow (or cause a voltage drop) during a transient event, thus protecting the pin and the device. Pins that are not used should **not** be left floating. They should instead be tied to GND or to an appropriate voltage through resistance.

8.2 Typical Application

The first example circuit will guide the user through component selection for an architectural accent lighting application. A regulated DC voltage input of 24 V \pm 10% will power a single 1-W white LED at a forward current of 350 mA \pm 5%. The typical forward voltage of a 1-W InGaN LED is 3.5 V, hence the estimated average output voltage will be 3.7 V. The objective of this application is to place the complete current regulator and LED in the compact space formerly occupied by an MR16 halogen light bulb. (The LED will be on a separate metal-core PCB.) Switching frequency will be as fast as the 300-ns t_{ON} limit allows, with the emphasis on space savings over efficiency. Efficiency cannot be ignored, however, because the confined space with little air-flow requires a maximum temperature rise of 40°C in each circuit component. A complete bill of materials can be found in [Table 2](#).

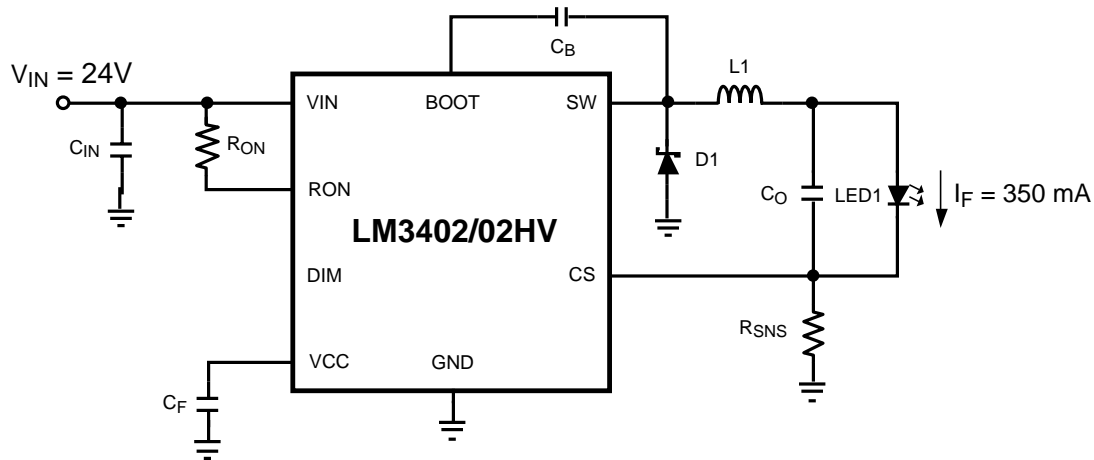
Typical Application (continued)

Figure 28. Schematic for Design Example 1
8.2.1 Design Requirements

Use the following parameters for this design example:

1. $V_{IN} = 24\text{ V} \pm 10\%$
2. $I_{LED} = 350\text{ mA}$
3. $V_{LED} = 3.5\text{ V}$, 1 LED

8.2.2 Detailed Design Procedure

Table 2 shows the body of materials for this design example.

Table 2. BOM for Design Example 1

ID	PART NUMBER	TYPE	SIZE	PARAMETERS	QTY	VENDOR
U1	LM3402	LED Driver	VSSOP-8	40 V, 0.5 A	1	NSC
L1	SLF7045T-330MR82	Inductor	7 × 7 × 4.5 mm	33 μH, 0.82 A, 96 mΩ	1	TDK
D1	CMHSH5-4	Schottky Diode	SOD-123	40 V, 0.5 A	1	Central Semi
Cf	VJ0805Y104KXXAT	Capacitor	0805	100 nF 10%	1	Vishay
Cb	VJ0805Y103KXXAT	Capacitor	0805	10n F 10%	1	Vishay
Cin	C3216X7R1H105M	Capacitor	1206	1 μF 50 V	1	TDK
Co	C2012X7R1A225M	Capacitor	0805	2.2 μF 10 V	1	TDK
Rsns	ERJ6BQFR75V	Resistor	0805	0.75 Ω 1%	1	Panasonic
Ron	CRCW08055902F	Resistor	0805	59 kΩ 1%	1	Vishay

8.2.2.1 R_{ON} and t_{ON}

 To select R_{ON} the expression relating t_{ON} to input voltage from the Controlled ON-time Overview section can be rewritten as Equation 18

$$R_{ON} = \frac{t_{ON} \times V_{IN}}{1.34 \times 10^{-10}} \quad (18)$$

 Minimum ON-time occurs at the maximum V_{IN} , which is $24\text{ V} \times 110\% = 26.4\text{ V}$. R_{ON} is therefore calculated using Equation 19.

$$R_{ON} = (300 \times 10^{-9} \times 26.4) / 1.34 \times 10^{-10} = 59105\ \Omega \quad (19)$$

The closest 1% tolerance resistor is 59 kΩ. The switching frequency of the circuit can then be found using the equation relating R_{ON} to f_{SW} :

$$f_{SW} = 3.7 / (59000 \times 1.34 \times 10^{-10}) = 468 \text{ kHz} \quad (20)$$

8.2.2.2 Using an Output Capacitor

The inductor will be the largest component used in this design. Because the application does not require any PWM dimming, an output capacitor can be used to greatly reduce the inductance needed without worry of slowing the potential PWM dimming frequency. The total solution size is reduced by using an output capacitor and small inductor as opposed to one large inductor.

8.2.2.3 Output Inductor

Knowing that an output capacitor will be used, the inductor can be selected for a larger current ripple. The desired maximum value for Δi_L is $\pm 30\%$, or $0.6 \times 350 \text{ mA} = 210 \text{ mA}_{P-P}$. Minimum inductance is selected at the maximum input voltage. Re-arranging the equation for current ripple selection yields the following:

$$L_{MIN} = \frac{V_{IN(MAX)} - V_O}{\Delta i_L} \times t_{ON} \quad (21)$$

$$L_{MIN} = [(26.4 - 3.7) \times 300 \times 10^{-9}] / (0.6 \times 0.35) = 32.4 \text{ } \mu\text{H} \quad (22)$$

The closest standard inductor value is 33 μH . Off-the-shelf inductors rated at 33 μH are available from many magnetics manufacturers.

Inductor data sheets should contain three specifications that are used to select the inductor. The first of these is the average current rating, which for a buck regulator is equal to the average load current, or I_F . The average current rating is given by a specified temperature rise in the inductor, normally 40°C. For this example, the average current rating should be greater than 350 mA to ensure that heat from the inductor does not reduce the lifetime of the LED or cause the LM3402 to enter thermal shutdown.

The second specification is the tolerance of the inductance itself, typically $\pm 10\%$ to $\pm 30\%$ of the rated inductance. In this example, designers use an inductor with a tolerance of $\pm 20\%$. With this tolerance the typical, minimum, and maximum inductor current ripples can be calculated using [Equation 23](#) to [Equation 25](#).

$$\Delta i_{L(TYP)} = [(26.4 - 3.7) \times 300 \times 10^{-9}] / 33 \times 10^{-6} = 206 \text{ mA}_{P-P} \quad (23)$$

$$\Delta i_{L(MIN)} = [(26.4 - 3.7) \times 300 \times 10^{-9}] / 39.6 \times 10^{-6} = 172 \text{ mA}_{P-P} \quad (24)$$

$$\Delta i_{L(MAX)} = [(26.4 - 3.7) \times 300 \times 10^{-9}] / 26.4 \times 10^{-6} = 258 \text{ mA}_{P-P} \quad (25)$$

The third specification for an inductor is the peak current rating, normally given as the point at which the inductance drops off by a given percentage due to saturation of the core. The worst-case peak current occurs at maximum input voltage and at minimum inductance, and can be determined with:

$$I_{L(PEAK)} = I_F + \frac{\Delta i_{L(MAX)}}{2} \quad (26)$$

$$I_{L(PEAK)} = 0.35 + 0.258 / 2 = 479 \text{ mA} \quad (27)$$

For this example the peak current rating of the inductor should be greater than 479 mA. In the case of a short circuit across the LED array, the LM3402 will continue to deliver rated current through the short but will reduce the output voltage to equal the CS pin voltage of 200 mV. Worst-case peak current in this condition is equal to:

$$\Delta i_{L(LED-SHORT)} = [(26.4 - 0.2) \times 300 \times 10^{-9}] / 26.4 \times 10^{-6} = 298 \text{ mA}_{P-P} \quad I_{L(PEAK)} = 0.35 + 0.149 = 499 \text{ mA} \quad (28)$$

In the case of a short at the switch node, the output, or from the CS pin to ground the short circuit current limit will engage at a typical peak current of 735 mA. To prevent inductor saturation during these short circuits the inductor's peak current rating must be above 735 mA. The device selected is an off-the-shelf inductor rated 33 $\mu\text{H} \pm 20\%$ with a DCR of 96 mΩ and a peak current rating of 0.82 A. The physical dimensions of this inductor are 7 × 7 × 4.5 mm.

8.2.2.3.1 R_{SNS}

The current sensing resistor value can be determined by re-arranging the expression for average LED current from the LED Current Accuracy section:

$$R_{\text{SNS}} = \frac{0.2 \times L}{I_{\text{F}} \times L + V_{\text{O}} \times t_{\text{SNS}} - \frac{V_{\text{IN}} - V_{\text{O}}}{2} \times t_{\text{ON}}} \quad (29)$$

$$R_{\text{SNS}} = 0.74\Omega, t_{\text{SNS}} = 220 \text{ ns} \quad (30)$$

Sub-1- Ω resistors are available in both 1% and 5% tolerance. A 1%, 0.75- Ω resistor will give the best accuracy of the average LED current. To determine the resistor size the power dissipation can be calculated using [Equation 31](#).

$$P_{\text{SNS}} = (I_{\text{F}})^2 \times R_{\text{SNS}} \quad P_{\text{SNS}} = 0.35^2 \times 0.75 = 92 \text{ mW} \quad (31)$$

Standard 0805 size resistors are rated to 125 mW and will be suitable for this application.

To select the proper output capacitor the equation from Buck Regulators with Output Capacitors is rearranged to yield the following:

$$Z_{\text{C}} = \frac{\Delta i_{\text{F}}}{\Delta i_{\text{L}} - \Delta i_{\text{F}}} \times r_{\text{D}} \quad (32)$$

The target tolerance for LED ripple current is $\pm 5\%$ or $10\%_{\text{P-P}} = 35 \text{ mA}_{\text{P-P}}$, and the LED data sheet gives a typical value for r_{D} of 1Ω at 350 mA. The required capacitor impedance to reduce the worst-case inductor ripple current of $258 \text{ mA}_{\text{P-P}}$ is therefore:

$$Z_{\text{C}} = [0.035 / (0.258 - 0.035)] \times 1 = 0.157 \Omega \quad (33)$$

A ceramic capacitor will be used and the required capacitance is selected based on the impedance at 468 kHz:

$$C_{\text{O}} = 1 / (2 \times \pi \times 0.157 \times 4.68 \times 10^5) = 2.18 \mu\text{F} \quad (34)$$

This calculation assumes that impedance due to the equivalent series resistance (ESR) and equivalent series inductance (ESL) of C_{O} is negligible. The closest 10% tolerance capacitor value is $2.2 \mu\text{F}$. The capacitor used should be rated to 10 V or more and have an X7R dielectric. Several manufacturers produce ceramic capacitors with these specifications in the 0805 case size. A typical value for ESR of $1 \text{ m}\Omega$ can be read from the curve of impedance vs frequency in the product data sheet.

8.2.2.4 Input Capacitor

Following the calculations from the Input Capacitor section, $\Delta V_{\text{IN(MAX)}}$ will be $1\%_{\text{P-P}} = 240 \text{ mV}$. The minimum required capacitance is:

$$C_{\text{IN(MIN)}} = (0.35 \times 300 \times 10^{-9}) / 0.24 = 438 \text{ nF} \quad (35)$$

In expectation that more capacitance will be needed to prevent power supply interaction a $1\text{-}\mu\text{F}$ ceramic capacitor rated to 50 V with X7R dielectric in a 1206 case size will be used. In this case, input rms current is:

$$I_{\text{IN-RMS}} = 0.35 \times \text{Sqrt}(0.154 \times 0.846) = 126 \text{ mA} \quad (36)$$

Ripple current ratings for 1206 size ceramic capacitors are typically higher than 1 A, more than enough for this design.

8.2.2.5 Recirculating Diode

The first parameter for D1 which must be determined is the reverse voltage rating. Schottky diodes are available at reverse ratings of 30 V and 40 V, often in the same package, with the same forward current rating. To account for ringing a 40-V Schottky will be used.

The next parameters to be determined are the forward current rating and case size. In this example the low duty cycle ($D = 3.7 / 24 = 15\%$) requires the recirculating diode D1 to carry the load current much longer than the internal power MOSFET of the LM3402. The estimated average diode current is:

$$I_{\text{D}} = 0.35 \times 0.85 = 298 \text{ mA} \quad (37)$$

Schottky diodes are available at forward current ratings of 0.5 A, however the current rating often assumes a 25°C ambient temperature and does not take into account the application restrictions on temperature rise. A diode rated for higher current may be needed to keep the temperature rise below 40°C. To determine the proper case size, the dissipation and temperature rise in D1 can be calculated as shown in the Design Considerations section. V_D for a small case size such as SOD-123 in a 40 V, 0.5-A Schottky diode at 350 mA is approximately 0.4 V and the θ_{JA} is 206°C/W. Power dissipation and temperature rise can be calculated as:

$$P_D = 0.298 \times 0.4 = 119 \text{ mW} \quad T_{RISE} = 0.119 \times 206 = 24.5^\circ\text{C} \quad (38)$$

According to these calculations the SOD-123 diode will meet the requirements. Heating and dissipation are among the factors most difficult to predict in converter design. If possible, a footprint should be used that is capable of accepting both SOD-123 and a larger case size, such as SMA. A larger diode with a higher forward current rating will generally have a lower forward voltage, reducing dissipation, as well as having a lower θ_{JA} , reducing temperature rise.

8.2.2.5.1 C_B and C_F

The bootstrap capacitor C_B should always be a 10 nF ceramic capacitor with X7R dielectric. A 25-V rating is appropriate for all application circuits. The linear regulator filter capacitor C_F should always be a 100-nF ceramic capacitor, also with X7R dielectric and a 25-V rating.

8.2.2.6 Efficiency

To estimate the electrical efficiency of this example the power dissipation in each current carrying element can be calculated and summed. This term should not be confused with the optical efficacy of the circuit, which depends upon the LEDs themselves.

Total output power, P_O , is calculated as:

$$P_O = I_F \times V_O = 0.35 \times 3.7 = 1.295 \text{ W} \quad (39)$$

Conduction loss, P_C , in the internal MOSFET:

$$P_C = (I_F^2 \times R_{DS(ON)}) \times D = (0.35^2 \times 1.5) \times 0.154 = 28 \text{ mW} \quad (40)$$

Gate charging and VCC loss, P_G , in the gate drive and linear regulator:

$$P_G = (I_{IN-OP} + f_{SW} \times Q_G) \times V_{IN} \quad P_G = (600 \times 10^{-6} + 468000 \times 3 \times 10^{-9}) \times 24 = 48 \text{ mW} \quad (41)$$

Switching loss, P_S , in the internal MOSFET:

$$P_S = 0.5 \times V_{IN} \times I_F \times (t_r + t_f) \times f_{SW} \quad P_S = 0.5 \times 24 \times 0.35 \times (40 \times 10^{-9}) \times 468000 = 78 \text{ mW} \quad (42)$$

AC rms current loss, P_{CIN} , in the input capacitor:

$$P_{CIN} = I_{IN(rms)}^2 \times ESR = (0.126)^2 \times 0.006 = 0.1 \text{ mW (negligible)} \quad (43)$$

DCR loss, P_L , in the inductor

$$P_L = I_F^2 \times DCR = 0.35^2 \times 0.096 = 11.8 \text{ mW} \quad (44)$$

Recirculating diode loss, $P_D = 119 \text{ mW}$

Current Sense Resistor Loss, $P_{SNS} = 92 \text{ mW}$

Electrical efficiency, $\eta = P_O / (P_O + \text{Sum of all loss terms}) = 1.295 / (1.295 + 0.377) = 77\%$

8.2.2.7 Die Temperature

$$T_{LM3402} = (P_C + P_G + P_S) \times \theta_{JA} \quad T_{LM3402} = (0.028 + 0.05 + 0.078) \times 200 = 31^\circ\text{C} \quad (45)$$

8.2.3 Application Curves

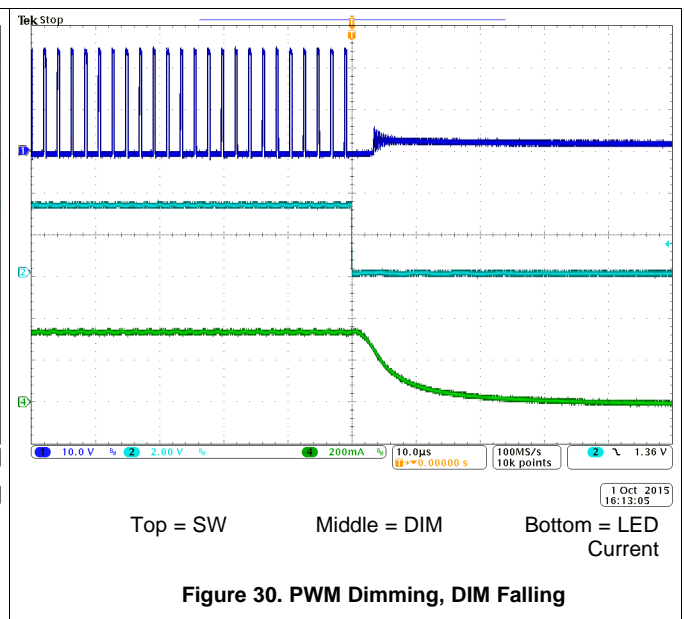
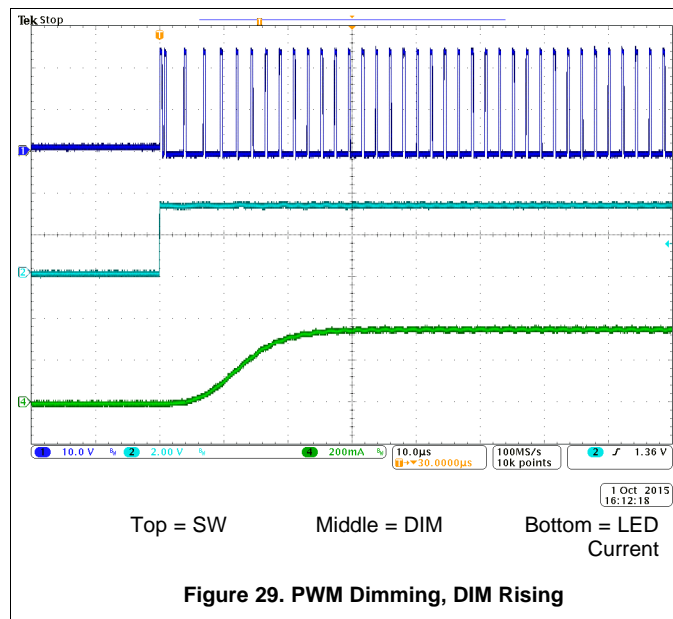

9 Power Supply Recommendations

Use any DC output power supply with a maximum voltage high enough for the application. The power supply should have a minimum current limit of at least 500 mA.

10 Layout

10.1 Layout Guidelines

The performance of any switching converter depends as much upon the layout of the PCB as the component selection. The following guidelines will help the user design a circuit with maximum rejection of outside EMI and minimum generation of unwanted EMI.

10.1.1 Compact Layout

Parasitic inductance can be reduced by keeping the power path components close together and keeping the area of the loops that high currents travel small. Short, thick traces or copper pours (shapes) are best. In particular, the switch node (where L1, D1, and the SW pin connect) should be just large enough to connect all three components without excessive heating from the current it carries. The LM3402/HV operates in two distinct cycles whose high current paths are shown in [Figure 22](#):

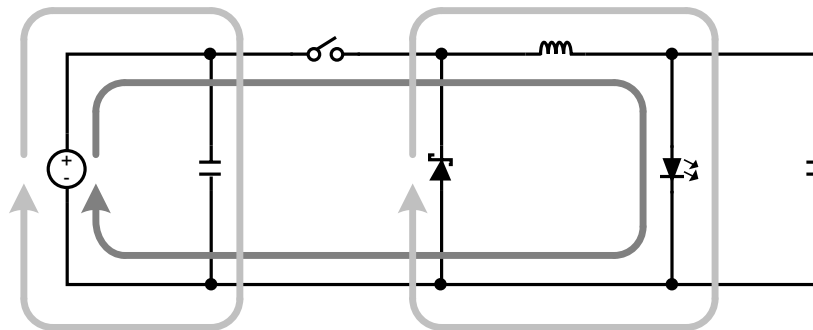

Figure 31. Buck Converter Current Loops

The dark grey, inner loop represents the high current path during the MOSFET ON-time. The light grey, outer loop represents the high current path during the off-time.

10.1.2 Ground Plane and Shape Routing

The diagram of [Figure 22](#) is also useful for analyzing the flow of continuous current vs the flow of pulsating currents. The circuit paths with current flow during both the ON-time and off-time are considered to be continuous current, while those that carry current during the ON-time or off-time only are pulsating currents. Preference in routing should be given to the pulsating current paths, as these are the portions of the circuit most likely to emit EMI. The ground plane of a PCB is a conductor and return path, and it is susceptible to noise injection just as any other circuit path. The continuous current paths on the ground net can be routed on the system ground plane with less risk of injecting noise into other circuits. The path between the input source and the input capacitor and the path between the recirculating diode and the LEDs/current sense resistor are examples of continuous current paths. In contrast, the path between the recirculating diode and the input capacitor carries a large pulsating current. This path should be routed with a short, thick shape, preferably on the component side of the PCB. Multiple vias in parallel should be used right at the pad of the input capacitor to connect the component side shapes to the ground plane. A second pulsating current loop that is often ignored is the gate drive loop formed by the SW and BOOT pins and capacitor CB. To minimize this loop at the EMI it generates, keep CB close to the SW and BOOT pins.

10.1.3 Current Sensing

The CS pin is a high-impedance input, and the loop created by R_{SNS} , R_Z (if used), the CS pin and ground should be made as small as possible to maximize noise rejection. R_{SNS} should therefore be placed as close as possible to the CS and GND pins of the IC.

Layout Guidelines (continued)

10.1.4 Remote LED Arrays

In some applications the LED or LED array can be far away (several inches or more) from the LM3402/HV, or on a separate PCB connected by a wiring harness. When an output capacitor is used and the LED array is large or separated from the rest of the converter, the output capacitor should be placed close to the LEDs to reduce the effects of parasitic inductance on the AC impedance of the capacitor. The current sense resistor should remain on the same PCB, close to the LM3402/HV.

10.2 Layout Example

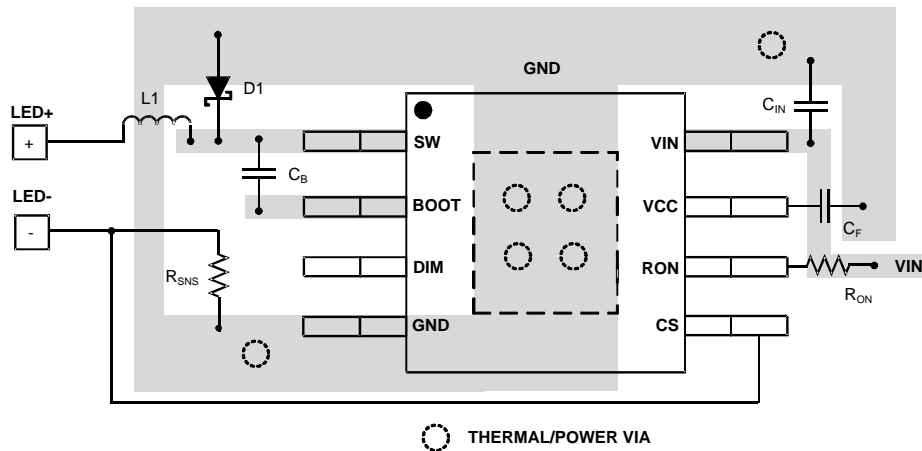

Figure 32. Layout Recommendation

11 Device and Documentation Support

11.1 Device Support

11.1.1 Third-Party Products Disclaimer

TI'S PUBLICATION OF INFORMATION REGARDING THIRD-PARTY PRODUCTS OR SERVICES DOES NOT CONSTITUTE AN ENDORSEMENT REGARDING THE SUITABILITY OF SUCH PRODUCTS OR SERVICES OR A WARRANTY, REPRESENTATION OR ENDORSEMENT OF SUCH PRODUCTS OR SERVICES, EITHER ALONE OR IN COMBINATION WITH ANY TI PRODUCT OR SERVICE.

11.2 Related Links

The table below lists quick access links. Categories include technical documents, support and community resources, tools and software, and quick access to sample or buy.

Table 3. Related Links

PARTS	PRODUCT FOLDER	SAMPLE & BUY	TECHNICAL DOCUMENTS	TOOLS & SOFTWARE	SUPPORT & COMMUNITY
LM3402	Click here	Click here	Click here	Click here	Click here
LM3402HV	Click here	Click here	Click here	Click here	Click here

11.3 Community Resources

The following links connect to TI community resources. Linked contents are provided "AS IS" by the respective contributors. They do not constitute TI specifications and do not necessarily reflect TI's views; see TI's [Terms of Use](#).

TI E2E™ Online Community *TI's Engineer-to-Engineer (E2E) Community*. Created to foster collaboration among engineers. At e2e.ti.com, you can ask questions, share knowledge, explore ideas and help solve problems with fellow engineers.

Design Support *TI's Design Support* Quickly find helpful E2E forums along with design support tools and contact information for technical support.

11.4 Trademarks

E2E is a trademark of Texas Instruments.
PowerPAD is a trademark of Texas Instruments .
All other trademarks are the property of their respective owners.

11.5 Electrostatic Discharge Caution



These devices have limited built-in ESD protection. The leads should be shorted together or the device placed in conductive foam during storage or handling to prevent electrostatic damage to the MOS gates.

11.6 Glossary

[SLYZ022](#) — *TI Glossary*.

This glossary lists and explains terms, acronyms, and definitions.

12 Mechanical, Packaging, and Orderable Information

The following pages include mechanical, packaging, and orderable information. This information is the most current data available for the designated devices. This data is subject to change without notice and revision of this document. For browser-based versions of this data sheet, refer to the left-hand navigation.

PACKAGING INFORMATION

Orderable Device	Status (1)	Package Type	Package Drawing	Pins	Package Qty	Eco Plan (2)	Lead/Ball Finish (6)	MSL Peak Temp (3)	Op Temp (°C)	Device Marking (4/5)	Samples
LM3402HVMM/NOPB	ACTIVE	VSSOP	DGK	8	1000	Green (RoHS & no Sb/Br)	CU SN	Level-1-260C-UNLIM	-40 to 125	SNFB	Samples
LM3402HVMMX/NOPB	ACTIVE	VSSOP	DGK	8	3500	Green (RoHS & no Sb/Br)	CU SN	Level-1-260C-UNLIM	-40 to 125	SNFB	Samples
LM3402HVMR/NOPB	ACTIVE	SO PowerPAD	DDA	8	95	Green (RoHS & no Sb/Br)	CU SN	Level-3-260C-168 HR		L3402 HVMR	Samples
LM3402HVMRX/NOPB	ACTIVE	SO PowerPAD	DDA	8	2500	Green (RoHS & no Sb/Br)	CU SN	Level-3-260C-168 HR		L3402 HVMR	Samples
LM3402MM	OBSOLETE	VSSOP	DGK	8		TBD	Call TI	Call TI	-40 to 125	SNEB	
LM3402MM/NOPB	ACTIVE	VSSOP	DGK	8	1000	Green (RoHS & no Sb/Br)	CU SN	Level-1-260C-UNLIM	-40 to 125	SNEB	Samples
LM3402MMX	OBSOLETE	VSSOP	DGK	8		TBD	Call TI	Call TI	-40 to 125	SNEB	
LM3402MMX/NOPB	ACTIVE	VSSOP	DGK	8	3500	Green (RoHS & no Sb/Br)	CU SN	Level-1-260C-UNLIM	-40 to 125	SNEB	Samples
LM3402MR/NOPB	ACTIVE	SO PowerPAD	DDA	8	95	Green (RoHS & no Sb/Br)	CU SN	Level-3-260C-168 HR		L3402 MR	Samples
LM3402MRX/NOPB	ACTIVE	SO PowerPAD	DDA	8	2500	Green (RoHS & no Sb/Br)	CU SN	Level-3-260C-168 HR		L3402 MR	Samples

(1) The marketing status values are defined as follows:

ACTIVE: Product device recommended for new designs.

LIFEBUY: TI has announced that the device will be discontinued, and a lifetime-buy period is in effect.

NRND: Not recommended for new designs. Device is in production to support existing customers, but TI does not recommend using this part in a new design.

PREVIEW: Device has been announced but is not in production. Samples may or may not be available.

OBSOLETE: TI has discontinued the production of the device.

(2) Eco Plan - The planned eco-friendly classification: Pb-Free (RoHS), Pb-Free (RoHS Exempt), or Green (RoHS & no Sb/Br) - please check <http://www.ti.com/productcontent> for the latest availability information and additional product content details.

TBD: The Pb-Free/Green conversion plan has not been defined.

Pb-Free (RoHS): TI's terms "Lead-Free" or "Pb-Free" mean semiconductor products that are compatible with the current RoHS requirements for all 6 substances, including the requirement that lead not exceed 0.1% by weight in homogeneous materials. Where designed to be soldered at high temperatures, TI Pb-Free products are suitable for use in specified lead-free processes.

Pb-Free (RoHS Exempt): This component has a RoHS exemption for either 1) lead-based flip-chip solder bumps used between the die and package, or 2) lead-based die adhesive used between the die and leadframe. The component is otherwise considered Pb-Free (RoHS compatible) as defined above.

Green (RoHS & no Sb/Br): TI defines "Green" to mean Pb-Free (RoHS compatible), and free of Bromine (Br) and Antimony (Sb) based flame retardants (Br or Sb do not exceed 0.1% by weight in homogeneous material)

- (3) MSL, Peak Temp. - The Moisture Sensitivity Level rating according to the JEDEC industry standard classifications, and peak solder temperature.
- (4) There may be additional marking, which relates to the logo, the lot trace code information, or the environmental category on the device.
- (5) Multiple Device Markings will be inside parentheses. Only one Device Marking contained in parentheses and separated by a "~" will appear on a device. If a line is indented then it is a continuation of the previous line and the two combined represent the entire Device Marking for that device.
- (6) Lead/Ball Finish - Orderable Devices may have multiple material finish options. Finish options are separated by a vertical ruled line. Lead/Ball Finish values may wrap to two lines if the finish value exceeds the maximum column width.

Important Information and Disclaimer:The information provided on this page represents TI's knowledge and belief as of the date that it is provided. TI bases its knowledge and belief on information provided by third parties, and makes no representation or warranty as to the accuracy of such information. Efforts are underway to better integrate information from third parties. TI has taken and continues to take reasonable steps to provide representative and accurate information but may not have conducted destructive testing or chemical analysis on incoming materials and chemicals. TI and TI suppliers consider certain information to be proprietary, and thus CAS numbers and other limited information may not be available for release.

In no event shall TI's liability arising out of such information exceed the total purchase price of the TI part(s) at issue in this document sold by TI to Customer on an annual basis.

TAPE AND REEL INFORMATION

QUADRANT ASSIGNMENTS FOR PIN 1 ORIENTATION IN TAPE

*All dimensions are nominal

Device	Package Type	Package Drawing	Pins	SPQ	Reel Diameter (mm)	Reel Width W1 (mm)	A0 (mm)	B0 (mm)	K0 (mm)	P1 (mm)	W (mm)	Pin1 Quadrant
LM3402HVMM/NOPB	VSSOP	DGK	8	1000	178.0	12.4	5.3	3.4	1.4	8.0	12.0	Q1
LM3402HVMMX/NOPB	VSSOP	DGK	8	3500	330.0	12.4	5.3	3.4	1.4	8.0	12.0	Q1
LM3402HVMRX/NOPB	SO Power PAD	DDA	8	2500	330.0	12.4	6.5	5.4	2.0	8.0	12.0	Q1
LM3402MM/NOPB	VSSOP	DGK	8	1000	178.0	12.4	5.3	3.4	1.4	8.0	12.0	Q1
LM3402MMX/NOPB	VSSOP	DGK	8	3500	330.0	12.4	5.3	3.4	1.4	8.0	12.0	Q1
LM3402MRX/NOPB	SO Power PAD	DDA	8	2500	330.0	12.4	6.5	5.4	2.0	8.0	12.0	Q1

TAPE AND REEL BOX DIMENSIONS

*All dimensions are nominal

Device	Package Type	Package Drawing	Pins	SPQ	Length (mm)	Width (mm)	Height (mm)
LM3402HVMM/NOPB	VSSOP	DGK	8	1000	210.0	185.0	35.0
LM3402HVMMX/NOPB	VSSOP	DGK	8	3500	367.0	367.0	35.0
LM3402HVMRX/NOPB	SO PowerPAD	DDA	8	2500	367.0	367.0	35.0
LM3402MM/NOPB	VSSOP	DGK	8	1000	210.0	185.0	35.0
LM3402MMX/NOPB	VSSOP	DGK	8	3500	367.0	367.0	35.0
LM3402MRX/NOPB	SO PowerPAD	DDA	8	2500	367.0	367.0	35.0

DGK (S-PDSO-G8)

PLASTIC SMALL-OUTLINE PACKAGE

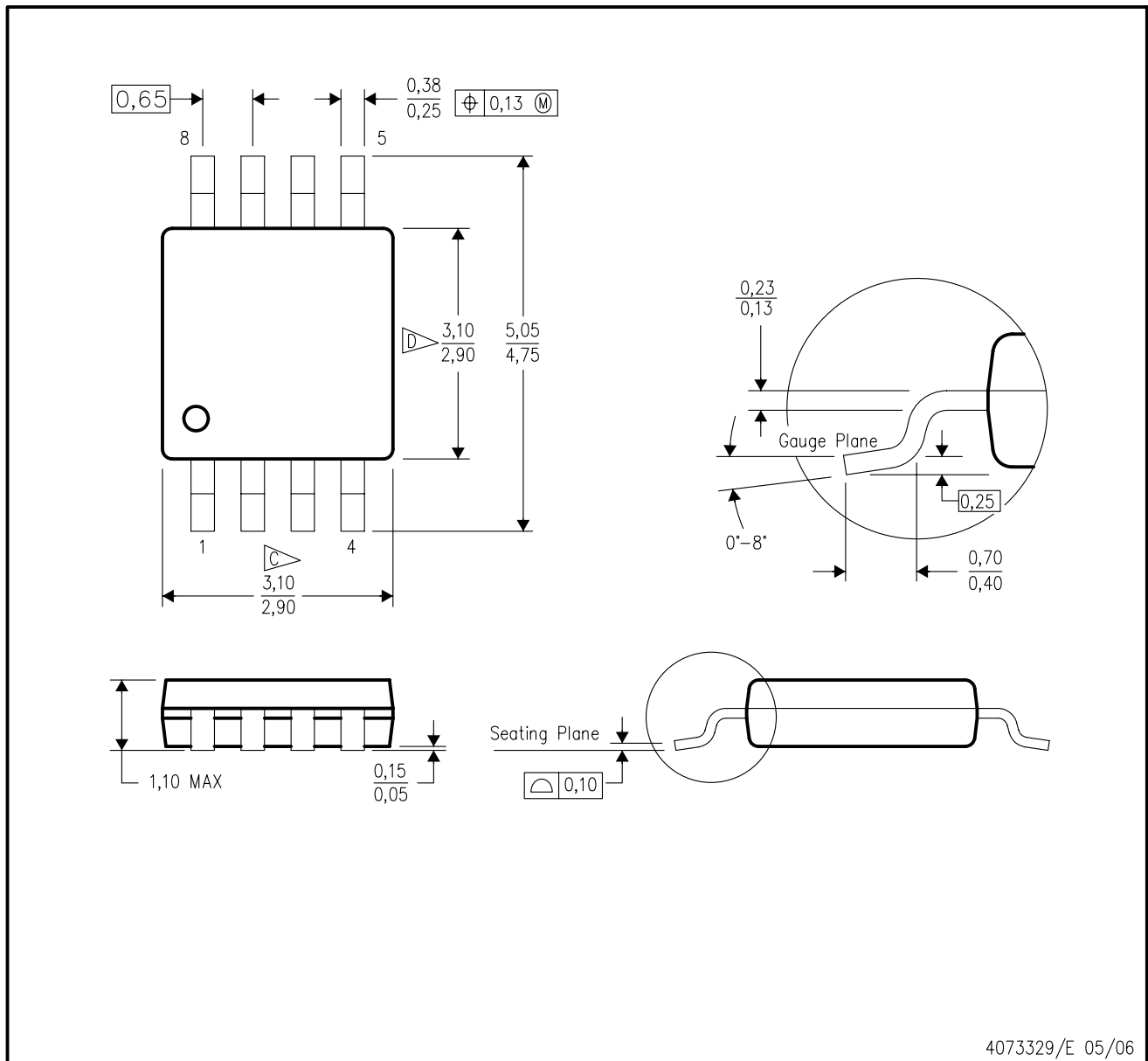

4073329/E 05/06

- NOTES:
- A. All linear dimensions are in millimeters.
 - B. This drawing is subject to change without notice.
 - C. Body length does not include mold flash, protrusions, or gate burrs. Mold flash, protrusions, or gate burrs shall not exceed 0.15 per end.
 - D. Body width does not include interlead flash. Interlead flash shall not exceed 0.50 per side.
 - E. Falls within JEDEC MO-187 variation AA, except interlead flash.



- NOTES:
- A. All linear dimensions are in millimeters.
 - B. This drawing is subject to change without notice.
 - C. Publication IPC-7351 is recommended for alternate designs.
 - D. Laser cutting apertures with trapezoidal walls and also rounding corners will offer better paste release. Customers should contact their board assembly site for stencil design recommendations. Refer to IPC-7525 for other stencil recommendations.
 - E. Customers should contact their board fabrication site for solder mask tolerances between and around signal pads.

DDA0008B

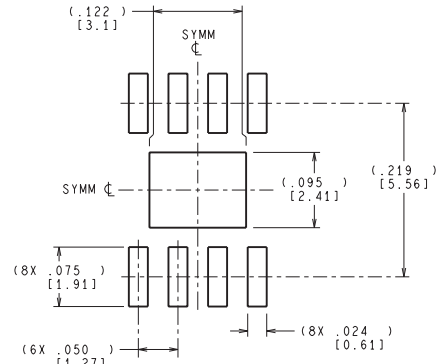
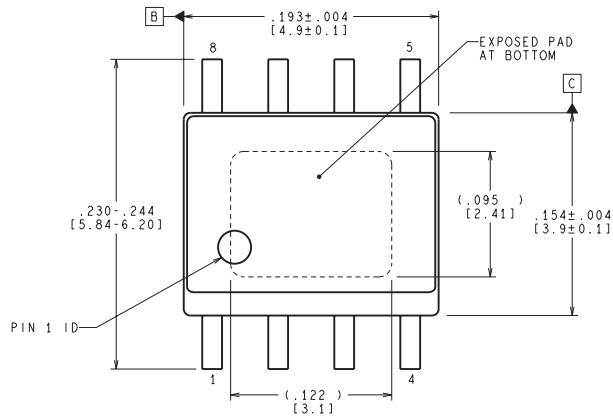

RECOMMENDED LAND PATTERN

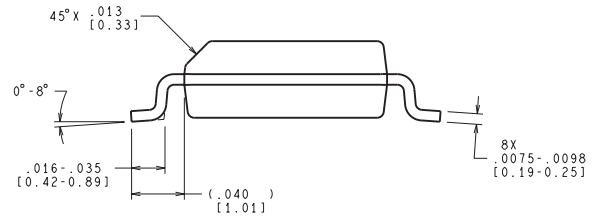
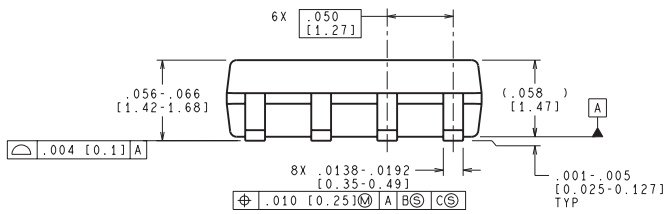

CONTROLLING DIMENSION IS INCH
VALUES IN [] ARE MILLIMETERS
DIMENSIONS IN () FOR REFERENCE ONLY

MRA08B (Rev B)

IMPORTANT NOTICE

Texas Instruments Incorporated and its subsidiaries (TI) reserve the right to make corrections, enhancements, improvements and other changes to its semiconductor products and services per JESD46, latest issue, and to discontinue any product or service per JESD48, latest issue. Buyers should obtain the latest relevant information before placing orders and should verify that such information is current and complete. All semiconductor products (also referred to herein as "components") are sold subject to TI's terms and conditions of sale supplied at the time of order acknowledgment.

TI warrants performance of its components to the specifications applicable at the time of sale, in accordance with the warranty in TI's terms and conditions of sale of semiconductor products. Testing and other quality control techniques are used to the extent TI deems necessary to support this warranty. Except where mandated by applicable law, testing of all parameters of each component is not necessarily performed.

TI assumes no liability for applications assistance or the design of Buyers' products. Buyers are responsible for their products and applications using TI components. To minimize the risks associated with Buyers' products and applications, Buyers should provide adequate design and operating safeguards.

TI does not warrant or represent that any license, either express or implied, is granted under any patent right, copyright, mask work right, or other intellectual property right relating to any combination, machine, or process in which TI components or services are used. Information published by TI regarding third-party products or services does not constitute a license to use such products or services or a warranty or endorsement thereof. Use of such information may require a license from a third party under the patents or other intellectual property of the third party, or a license from TI under the patents or other intellectual property of TI.

Reproduction of significant portions of TI information in TI data books or data sheets is permissible only if reproduction is without alteration and is accompanied by all associated warranties, conditions, limitations, and notices. TI is not responsible or liable for such altered documentation. Information of third parties may be subject to additional restrictions.

Resale of TI components or services with statements different from or beyond the parameters stated by TI for that component or service voids all express and any implied warranties for the associated TI component or service and is an unfair and deceptive business practice. TI is not responsible or liable for any such statements.

Buyer acknowledges and agrees that it is solely responsible for compliance with all legal, regulatory and safety-related requirements concerning its products, and any use of TI components in its applications, notwithstanding any applications-related information or support that may be provided by TI. Buyer represents and agrees that it has all the necessary expertise to create and implement safeguards which anticipate dangerous consequences of failures, monitor failures and their consequences, lessen the likelihood of failures that might cause harm and take appropriate remedial actions. Buyer will fully indemnify TI and its representatives against any damages arising out of the use of any TI components in safety-critical applications.

In some cases, TI components may be promoted specifically to facilitate safety-related applications. With such components, TI's goal is to help enable customers to design and create their own end-product solutions that meet applicable functional safety standards and requirements. Nonetheless, such components are subject to these terms.

No TI components are authorized for use in FDA Class III (or similar life-critical medical equipment) unless authorized officers of the parties have executed a special agreement specifically governing such use.

Only those TI components which TI has specifically designated as military grade or "enhanced plastic" are designed and intended for use in military/aerospace applications or environments. Buyer acknowledges and agrees that any military or aerospace use of TI components which have **not** been so designated is solely at the Buyer's risk, and that Buyer is solely responsible for compliance with all legal and regulatory requirements in connection with such use.

TI has specifically designated certain components as meeting ISO/TS16949 requirements, mainly for automotive use. In any case of use of non-designated products, TI will not be responsible for any failure to meet ISO/TS16949.

Products

Audio	www.ti.com/audio
Amplifiers	amplifier.ti.com
Data Converters	dataconverter.ti.com
DLP® Products	www.dlp.com
DSP	dsp.ti.com
Clocks and Timers	www.ti.com/clocks
Interface	interface.ti.com
Logic	logic.ti.com
Power Mgmt	power.ti.com
Microcontrollers	microcontroller.ti.com
RFID	www.ti-rfid.com
OMAP Applications Processors	www.ti.com/omap
Wireless Connectivity	www.ti.com/wirelessconnectivity

Applications

Automotive and Transportation	www.ti.com/automotive
Communications and Telecom	www.ti.com/communications
Computers and Peripherals	www.ti.com/computers
Consumer Electronics	www.ti.com/consumer-apps
Energy and Lighting	www.ti.com/energy
Industrial	www.ti.com/industrial
Medical	www.ti.com/medical
Security	www.ti.com/security
Space, Avionics and Defense	www.ti.com/space-avionics-defense
Video and Imaging	www.ti.com/video

TI E2E Community

e2e.ti.com