

## BACKUP-BATTERY SUPERVISORS FOR RAM RETENTION

Check for Samples: [TPS3619-33-EP](#), [TPS3619-50-EP](#), [TPS3620-33-EP](#), [TPS3620-50-EP](#)

### FEATURES

- Supply Current of 40  $\mu$ A (Max)
- Battery-Supply Current of 100 nA (Max)
- Precision Supply-Voltage Monitor 3.3 V, 5 V, and Other Options on Request
- Backup-Battery Voltage Can Exceed  $V_{DD}$
- Power-On Reset Generator with Fixed 100-ms Reset Delay Time
- Voltage Monitor for Power-Fail or Low-Battery Monitoring
- Battery Freshness Seal (TPS3619)
- Pin-to-Pin Compatible With MAX819, MAX703, and MAX704
- 8-Pin Mini Small-Outline Package (MSOP) Package

### SUPPORTS DEFENSE, AEROSPACE, AND MEDICAL APPLICATIONS

- Controlled Baseline
- One Assembly/Test Site
- One Fabrication Site
- Available in Military ( $-55^{\circ}\text{C}/125^{\circ}\text{C}$ ) Temperature Range<sup>(1)</sup>
- Extended Product Life Cycle
- Extended Product-Change Notification
- Product Traceability

(1) Additional temperature ranges available - contact factory

### APPLICATIONS

- Fax Machines
- Set-Top Boxes
- Advanced Voice-Mail Systems
- Portable Battery-Powered Equipment
- Computer Equipment
- Advanced Modems
- Automotive Systems
- Portable Long-Time Monitoring Equipment
- Point-of-Sale Equipment

### DESCRIPTION

The TPS3619 and TPS3620 families of supervisory circuits monitor and control processor activity by providing backup-battery switchover for data retention of CMOS RAM.

During power on,  $\overline{\text{RESET}}$  is asserted when the supply voltage ( $V_{DD}$  or  $V_{BAT}$ ) becomes higher than 1.1 V. Thereafter, the supply voltage supervisor monitors  $V_{DD}$  and keeps  $\overline{\text{RESET}}$  output active as long as  $V_{DD}$  remains below the threshold voltage ( $V_{IT}$ ). An internal timer delays the return of the output to the inactive state (high) to ensure proper system reset. The delay time starts after  $V_{DD}$  has risen above  $V_{IT}$ . When the supply voltage drops below  $V_{IT}$ , the output becomes active (low) again.

The product spectrum is designed for supply voltages of 3.3 V and 5 V. The TPS3619 and TPS3620 are available in an 8-pin MSOP package and are characterized for operation over a temperature range of  $-55^{\circ}\text{C}$  to  $125^{\circ}\text{C}$ .

DGK PACKAGE  
(TOP VIEW)

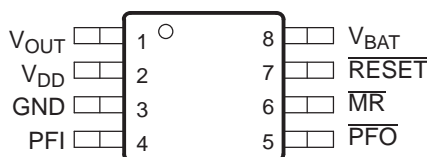

**ACTUAL SIZE**  
3,05 mm x 4,98 mm



Please be aware that an important notice concerning availability, standard warranty, and use in critical applications of Texas Instruments semiconductor products and disclaimers thereto appears at the end of this data sheet.



This integrated circuit can be damaged by ESD. Texas Instruments recommends that all integrated circuits be handled with appropriate precautions. Failure to observe proper handling and installation procedures can cause damage.

ESD damage can range from subtle performance degradation to complete device failure. Precision integrated circuits may be more susceptible to damage because very small parametric changes could cause the device not to meet its published specifications.

### TYPICAL OPERATING CIRCUIT

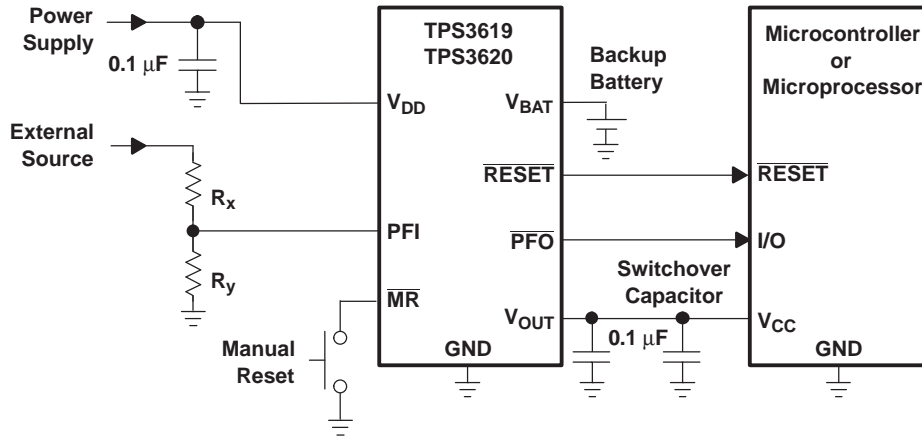

### PACKAGE INFORMATION<sup>(1)</sup>

T <sub>A</sub>	PRODUCT	PACKAGE MARKING	ORDERABLE PART NUMBER	TRANSPORT MEDIA, QUANTITY
-55°C to 125°C	TPS3619-33	BZP	TPS3619-33MDGKEP <sup>(2)</sup>	Tube, 80
			TPS3619-33MDGKREP	Tape and reel, 2500
	TPS3619-50	TBD	TPS3619-50MDGK <sup>(2)</sup>	Tube, 80
			TPS3619-50MDGKREP <sup>(2)</sup>	Tape and reel, 2500
	TPS3620-33	BTY	TPS3620-33MDGKTPEP	Tape and reel, 250
			TPS3620-33MDGKREP	Tape and reel, 2500
	TPS3620-50	TBD	TPS3620-50MDGKTPEP <sup>(2)</sup>	Tape and reel, 250
			TPS3620-50MDGKREP <sup>(2)</sup>	Tape and reel, 2500

(1) For the most current specifications and package information, see the Package Option Addendum located at the end of this data sheet or see the TI web site at [www.ti.com](http://www.ti.com).

(2) Product Preview. Parameters in electrical characteristics are subject to change.

### Standard and Application-Specific Versions

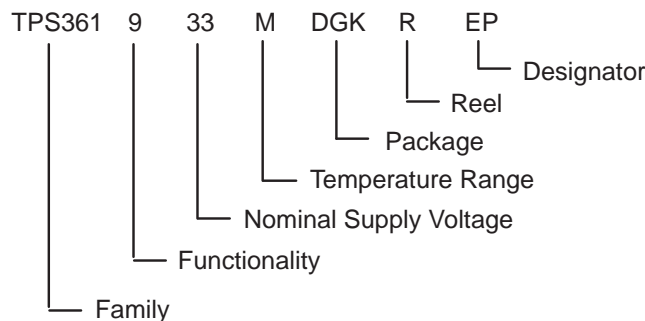

DEVICE NAME	NOMINAL VOLTAGE <sup>(1)</sup> , V <sub>NOM</sub>
TPS3619-33 DGK	3.3 V
TPS3619-50 DGK	5 V
TPS3620-33 DGK	3.3 V
TPS3620-50 DGK	5 V

(1) For other threshold voltage versions, contact the local TI sales office for availability and lead time.

## Absolute Maximum Ratings

over operating free-air temperature (unless otherwise noted)<sup>(1)</sup>

		UNIT
Supply voltage	$V_{DD}$ <sup>(2)</sup>	7 V
	$\overline{MR}$ and PFI pins <sup>(2)</sup>	-0.3 V to ( $V_{DD} + 0.3$ V)
Continuous output current, $I_O$	$V_{OUT}$	400 mA
	All other pins <sup>(2)</sup>	±10 mA
Continuous total power dissipation		See Dissipation Ratings Table
Operating free-air temperature range, $T_A$		-55°C to 125°C
Storage temperature range, $T_{stg}$		-65°C to 150°C
Lead temperature soldering 1,6 mm (1/16 in) from case for 10 s		260°C

- (1) Stresses beyond those listed under *absolute maximum ratings* may cause permanent damage to the device. These are stress ratings only, and functional operation of the device at these or any other conditions beyond those indicated under recommended operating conditions is not implied. Exposure to absolute-maximum-rated conditions for extended periods may affect device reliability.
- (2) All voltage values are with respect to GND. For reliable operation, the device must not be continuously operated at 7 V for more than  $t = 1000$  h.

## Dissipation Ratings

PACKAGE	$T_A < 25^\circ\text{C}$ POWER RATING	DERATING FACTOR ABOVE $T_A = 25^\circ\text{C}$	$T_A = 70^\circ\text{C}$ POWER RATING	$T_A = 85^\circ\text{C}$ POWER RATING	$T_A = 125^\circ\text{C}$ POWER RATING
DGK	470 mW	3.76 mW/°C	301 mW	241 mW	93.98 mW

## Recommended Operating Conditions

at specified temperature range

		MIN	MAX	UNIT
$V_{DD}$	Supply voltage	1.65	5.5	V
$V_{BAT}$	Battery supply voltage	1.5	5.5	V
$V_I$	Input voltage	0	$V_{DD} + 0.3$	V
$V_{IH}$	High-level input voltage	$0.7 \times V_{DD}$		V
$V_{IL}$	Low-level input voltage		$0.3 \times V_{DD}$	V
$I_O$	Continuous output current at $V_{OUT}$		300	mA
	Input transition rise and fall rate at $\overline{MR}$		100	ns/V
$\Delta t/\Delta V$	Slew rate at $V_{DD}$ or $V_{BAT}$		1	V/ $\mu$ s
$T_A$	Operating free-air temperature	-55	125	°C

## Electrical Characteristics

over recommended operating conditions (unless otherwise noted)

PARAMETER		TEST CONDITIONS		MIN	TYP	MAX	UNIT
V <sub>OH</sub>	High-level output voltage	$\overline{\text{RESET}}$	V <sub>DD</sub> = 3.3 V, I <sub>OH</sub> = -2 mA	V <sub>DD</sub> - 0.4			V
			V <sub>DD</sub> = 5 V, I <sub>OH</sub> = -3 mA	V <sub>DD</sub> - 0.4			
		$\overline{\text{PFO}}$	V <sub>DD</sub> = 1.8 V, I <sub>OH</sub> = -20 μA	V <sub>DD</sub> - 0.3			
			V <sub>DD</sub> = 3.3 V, I <sub>OH</sub> = -80 μA	V <sub>DD</sub> - 0.4			
V <sub>OL</sub>	Low-level output voltage	$\overline{\text{RESET}}, \overline{\text{PFO}}$	V <sub>DD</sub> = 1.8 V, I <sub>OL</sub> = -400 μA	0.2			V
			V <sub>DD</sub> = 3.3 V, I <sub>OL</sub> = 2 mA	0.4			
			V <sub>DD</sub> = 5 V, I <sub>OL</sub> = 3 mA	0.4			
V <sub>res</sub>	Power-up reset voltage <sup>(1)</sup>		I <sub>OL</sub> = 20 μA, V <sub>BAT</sub> > 1.1 V or V <sub>DD</sub> > 1.1 V	0.4			V
V <sub>OUT</sub>	Normal mode		I <sub>OUT</sub> = 8.5 mA, V <sub>BAT</sub> = 0 V, V <sub>DD</sub> = 1.8 V	V <sub>DD</sub> - 50			mV
			I <sub>OUT</sub> = 125 mA, V <sub>BAT</sub> = 0 V, V <sub>DD</sub> = 3.3 V	V <sub>DD</sub> - 150			
			I <sub>OUT</sub> = 190 mA, V <sub>BAT</sub> = 0 V, V <sub>DD</sub> = 5 V	V <sub>DD</sub> - 200			
	Battery-backup mode	I <sub>OUT</sub> = 0.5 mA, V <sub>BAT</sub> = 1.5 V, V <sub>DD</sub> = 0 V	V <sub>BAT</sub> - 50				
I <sub>OUT</sub> = 7.5 mA, V <sub>BAT</sub> = 3.3 V		V <sub>BAT</sub> - 150					
r <sub>DS(on)</sub>	V <sub>DD</sub> to V <sub>OUT</sub> on resistance		V <sub>DD</sub> = 5 V	0.6	1		Ω
	V <sub>BAT</sub> to V <sub>OUT</sub> on resistance		V <sub>DD</sub> = 3.3 V	8	20		
V <sub>IT-</sub>	Negative-going input threshold voltage <sup>(2)</sup>	TPS36XX-33	T <sub>A</sub> = -55°C to 125°C	2.88	2.93	3.05	V
		TPS36XX-50		4.46	4.55	4.64	
V <sub>PFI</sub>			T <sub>A</sub> = -55°C to 125°C	1.13	1.15	1.185	V
V <sub>hys</sub>	Hysteresis	V <sub>IT</sub>	1.65 V < V <sub>IT</sub> < 2.5 V	20			mV
			2.5 V < V <sub>IT</sub> < 3.5 V	40			
			3.5 V < V <sub>IT</sub> < 5.5 V	60			
		PFI	12				
		VBSW <sup>(3)</sup>	V <sub>DD</sub> = 1.8 V	55			
I <sub>IH</sub>	High-level input current	$\overline{\text{MR}}$	$\overline{\text{MR}} = 0.7 \times V_{DD}$ , V <sub>DD</sub> = 5 V	-30	-76		μA
I <sub>IL</sub>	Low-level input current	$\overline{\text{MR}}$	$\overline{\text{MR}} = 0$ V, V <sub>DD</sub> = 5 V	-110	-255		μA
I <sub>I</sub>	Input current	PFI		-25	25		nA
I <sub>OS</sub>	Short-circuit current	$\overline{\text{PFO}}$	$\overline{\text{PFO}} = 0$ V	V <sub>DD</sub> = 1.8 V	-0.3		mA
				V <sub>DD</sub> = 3.3 V	-1.1		
				V <sub>DD</sub> = 5 V	-2.4		
I <sub>DD</sub>	V <sub>DD</sub> supply current		V <sub>OUT</sub> = V <sub>DD</sub>	40			μA
			V <sub>OUT</sub> = V <sub>BAT</sub>	40			
I <sub>(BAT)</sub>	V <sub>BAT</sub> supply current		V <sub>OUT</sub> = V <sub>DD</sub>	-0.1	0.1		μA
			V <sub>OUT</sub> = V <sub>BAT</sub>	0.5			
C <sub>I</sub>	Input capacitance		V <sub>I</sub> = 0 V to 5 V	5			pF

(1) The lowest supply voltage at which  $\overline{\text{RESET}}$  becomes active. t<sub>r,VDD</sub> ≥ 15 μs/V.

(2) To ensure the best stability of the threshold voltage, a bypass capacitor (ceramic, 0.1 μF) should be placed near the supply terminals.

(3) For V<sub>DD</sub> < 1.6 V, V<sub>OUT</sub> switches to V<sub>BAT</sub>, regardless of V<sub>BAT</sub>.

## Timing Requirements

 at  $R_L = 1\text{ M}\Omega$ ,  $C_L = 50\text{ pF}$ ,  $T_A = 25^\circ\text{C}$ 

PARAMETER		TEST CONDITIONS	MIN	MAX	UNIT
$t_w$	Pulse width	at $V_{DD}$	$V_{IH} = V_{IT} + 0.2\text{ V}$ , $V_{IL} = V_{IT} - 0.2\text{ V}$		$\mu\text{s}$
		at $\overline{\text{MR}}$	$V_{DD} = V_{IT} + 0.2\text{ V}$ , $V_{IL} = 0.3 \times V_{DD}$ , $V_{IH} = 0.7 \times V_{DD}$		ns

## Switching Characteristics

 at  $R_L = 1\text{ M}\Omega$ ,  $C_L = 50\text{ pF}$ ,  $T_A = -55^\circ\text{C}$  to  $125^\circ\text{C}$ 

PARAMETER		TEST CONDITIONS	MIN	TYP	MAX	UNIT
$t_d$	Delay time	$V_{DD} \geq V_{IT} + 0.2\text{ V}$ , $\overline{\text{MR}} \geq 0.7 \times V_{DD}$ , See timing diagram	60	100	140	ms
$t_{PHL}$	Propagation (delay) time, high-to-low-level output	$V_{DD}$ to $\overline{\text{RESET}}$	$V_{IL} = V_{IT} - 0.4\text{ V}$ , $V_{IH} = V_{IT} + 0.4\text{ V}$		2	5
		PFI to $\overline{\text{PFO}}$ delay	$V_{IL} = V_{PFI} - 0.35\text{ V}$ , $V_{IH} = V_{PFI} + 0.35\text{ V}$		3	5
		$\overline{\text{MR}}$ to $\overline{\text{RESET}}$	$V_{DD} \geq V_{IT} + 0.2\text{ V}$ , $V_{IL} = 0.3 \times V_{DD}$ , $V_{IH} = 0.7 \times V_{DD}$		0.1	1

### Timing Diagram

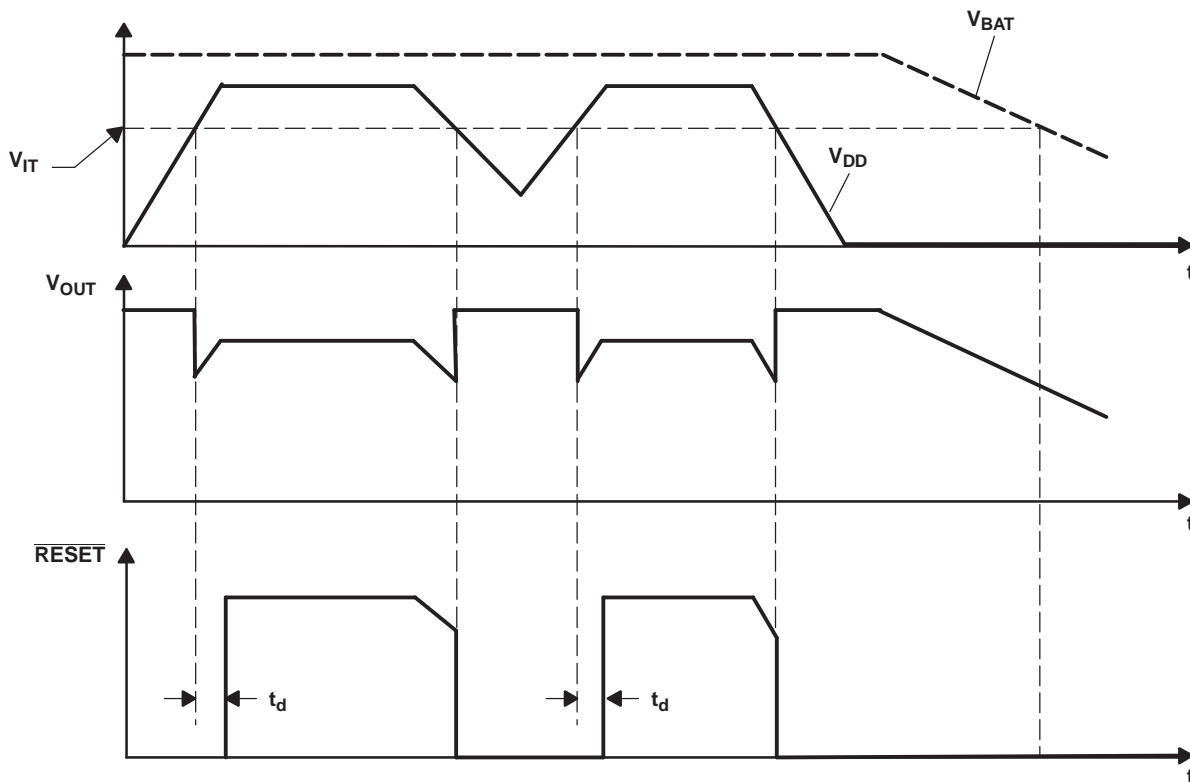

**Table 1. FUNCTION TABLE**

$V_{DD} > V_{IT}$	$V_{DD} > V_{BAT}$	$\overline{MR}$	$V_{OUT}$	$\overline{RESET}$
0	0	L	$V_{BAT}$	L
0	0	H	$V_{BAT}$	L
0	1	L	$V_{DD}$	L
0	1	H	$V_{DD}$	L
1	0	L	$V_{DD}$	L
1	0	H	$V_{DD}$	H
1	1	L	$V_{DD}$	L
1	1	H	$V_{DD}$	H

$PFI > V_{PFI}$	$\overline{PFO}$
0	L
1	H
CONDITION: $V_{DD} > V_{DD(MIN)}$	

**TERMINAL FUNCTIONS**

TERMINAL		I/O	DESCRIPTION
NAME	NO.		
GND	3	I	Ground
$\overline{MR}$	6	I	Manual reset
PFI	4	I	Power-fail comparator input
$\overline{PFO}$	5	O	Power-fail comparator output
$\overline{RESET}$	7	O	Active-low reset
$V_{BAT}$	8	I	Backup battery
$V_{DD}$	2	I	Supply input voltage
$V_{OUT}$	1	O	Supply output voltage

FUNCTIONAL BLOCK DIAGRAM

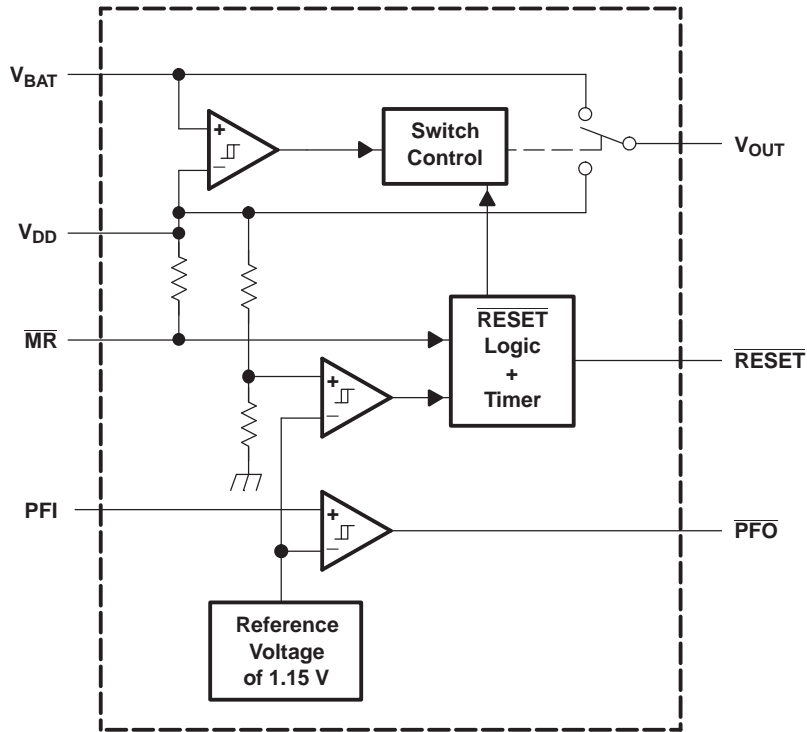

**TYPICAL CHARACTERISTICS**

**STATIC DRAIN-SOURCE ON-STATE RESISTANCE**  
 ( $V_{DD}$  to  $V_{OUT}$ )  
 vs  
**OUTPUT CURRENT**

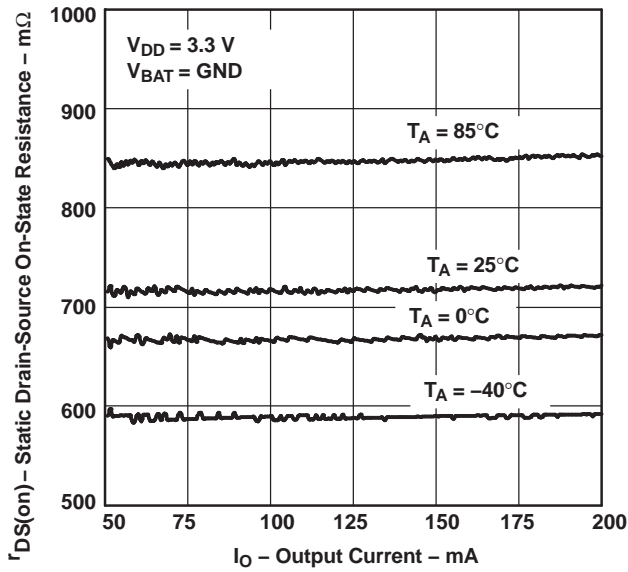

Figure 1.

**STATIC DRAIN-SOURCE ON-STATE RESISTANCE**  
 ( $V_{BAT}$  to  $V_{OUT}$ )  
 vs  
**OUTPUT CURRENT**

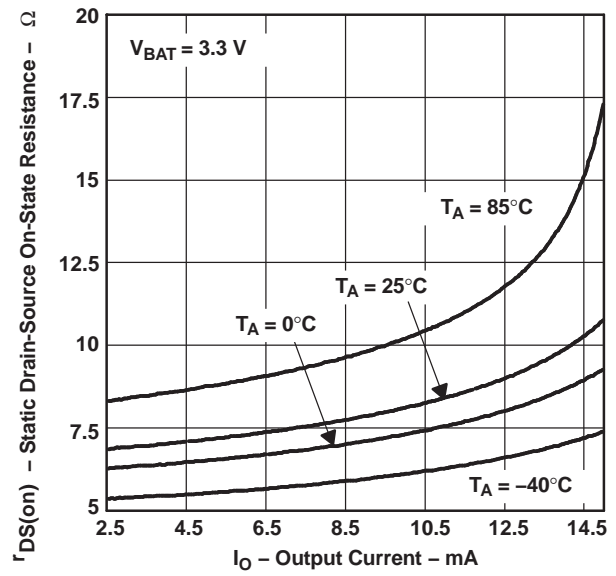

Figure 2.

**SUPPLY CURRENT**  
 vs  
**SUPPLY VOLTAGE**

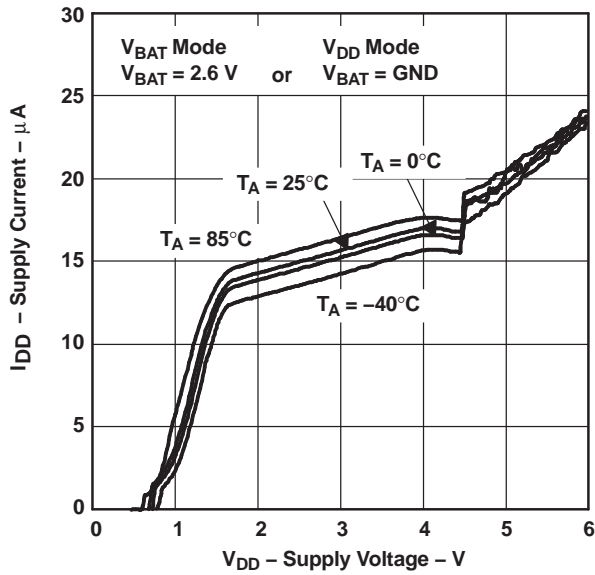

Figure 3.

**NORMALIZED THRESHOLD AT RESET**  
 vs  
**FREE-AIR TEMPERATURE**

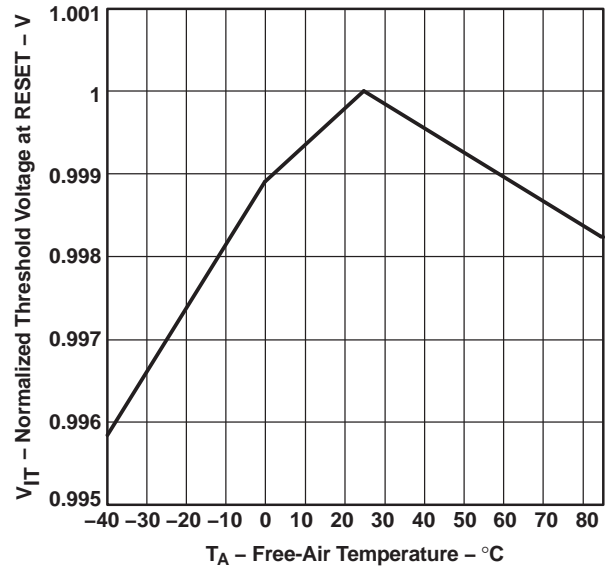

Figure 4.



TYPICAL CHARACTERISTICS (continued)

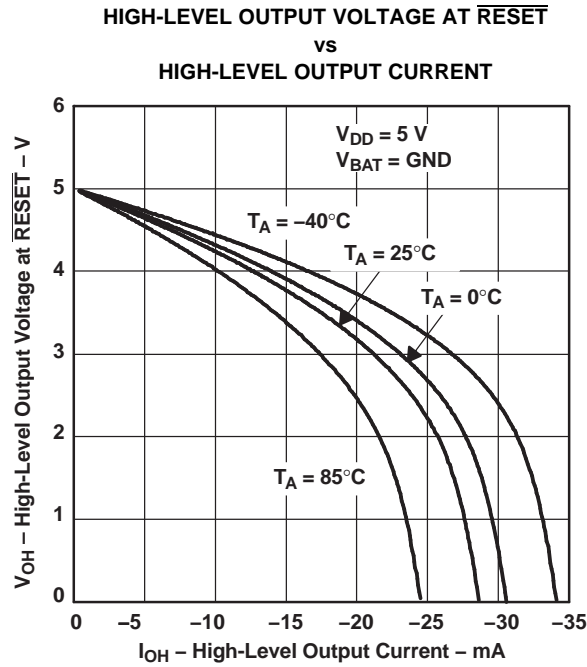

Figure 5.

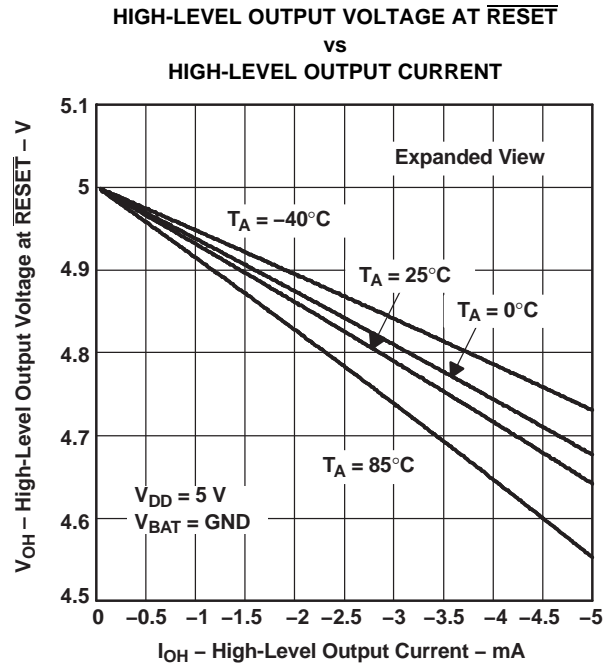

Figure 6.

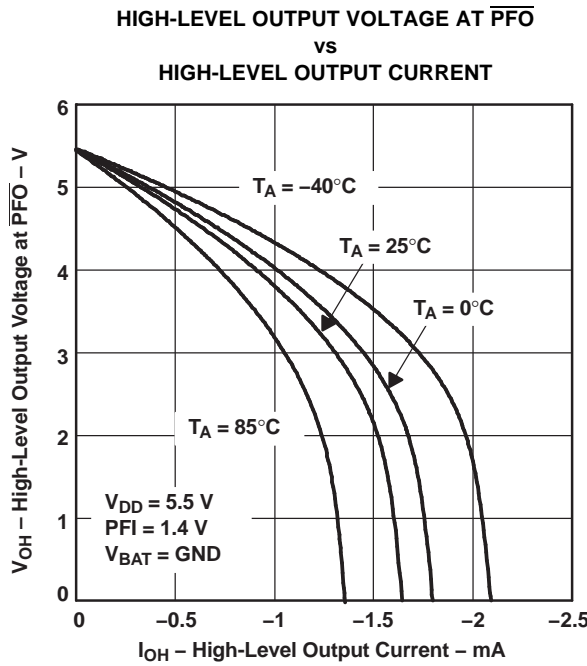

Figure 7.

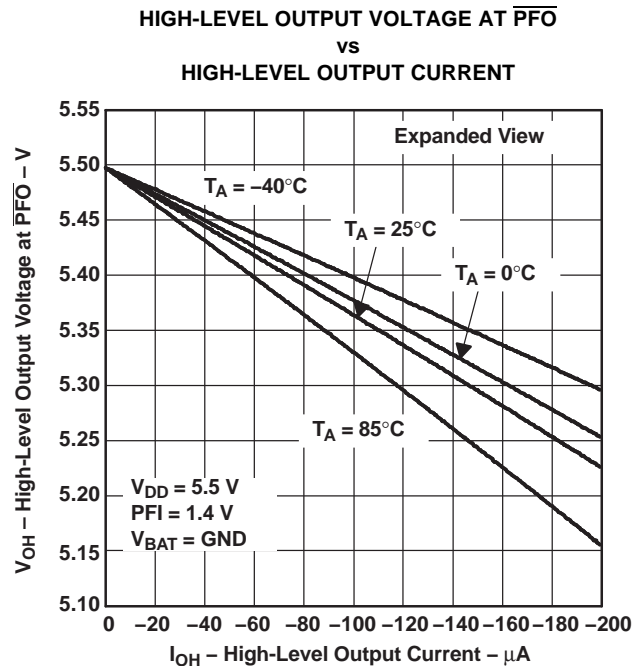

Figure 8.

**TYPICAL CHARACTERISTICS (continued)**

**LOW-LEVEL OUTPUT VOLTAGE AT  $\overline{\text{RESET}}$**   
 vs  
**LOW-LEVEL OUTPUT CURRENT**

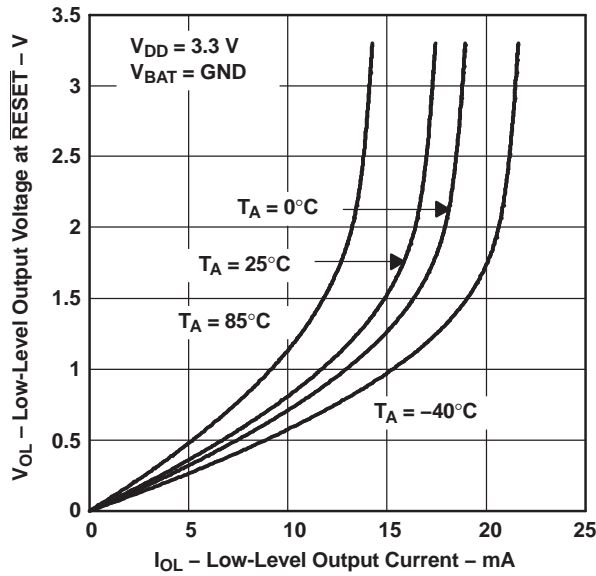

Figure 9.

**LOW-LEVEL OUTPUT VOLTAGE AT  $\overline{\text{RESET}}$**   
 vs  
**LOW-LEVEL OUTPUT CURRENT**

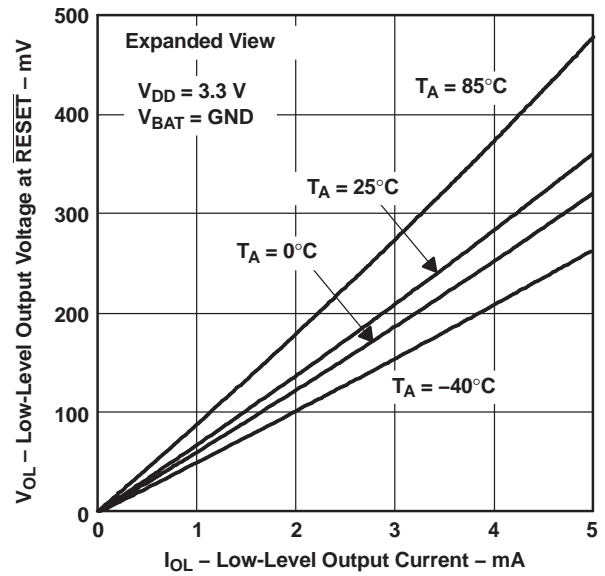

Figure 10.

**MINIMUM PULSE DURATION AT V<sub>DD</sub>**  
 vs  
**THRESHOLD OVERDRIVE AT V<sub>DD</sub>**

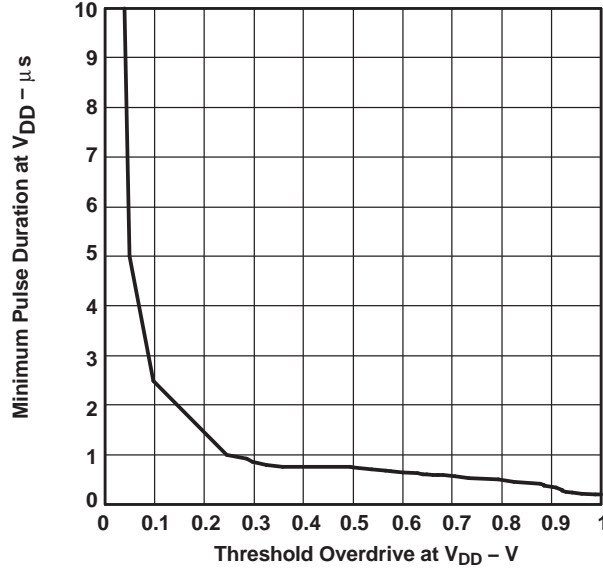

Figure 11.

**MINIMUM PULSE DURATION AT PFI**  
 vs  
**THRESHOLD OVERDRIVE AT PFI**

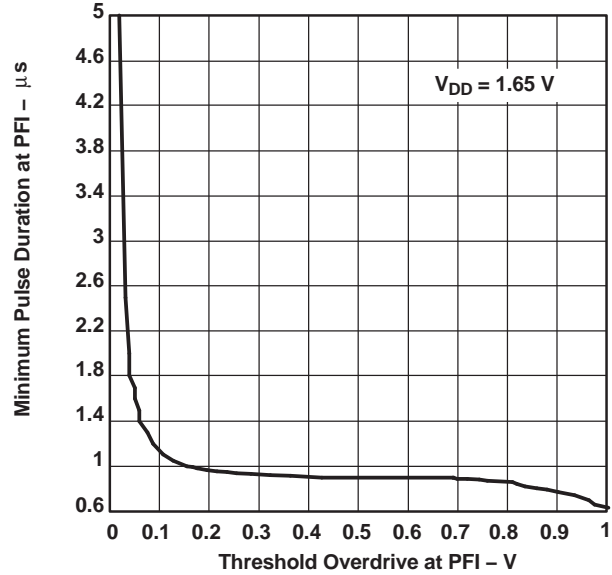

Figure 12.

## DETAILED DESCRIPTION

### Battery Freshness Seal (TPS3619)

The battery freshness seal of the TPS3619 family disconnects the backup battery from internal circuitry until it is needed. This function prevents the backup battery from being discharged until the final product is put to use. The following steps explain how to enable the freshness seal mode.

1. Connect  $V_{BAT}$  ( $V_{BAT} > V_{BAT\ min}$ )
2. Ground  $\overline{PFO}$
3. Connect PFI to  $V_{DD}$  ( $PFI = V_{DD}$ )
4. Connect  $V_{DD}$  to power supply ( $V_{DD} > V_{IT}$ ) and retain for  $5\ ms < t < 35\ ms$

The battery freshness seal mode is removed automatically by the positive-going edge of  $\overline{RESET}$  when  $V_{DD}$  is applied.

### Power-Fail Input/Output Comparator (PFI and $\overline{PFO}$ )

An additional comparator is provided to monitor voltages other than the nominal supply voltage. The PFI is compared with an internal voltage reference of 1.15 V. If the input voltage falls below the power-fail threshold ( $V_{IT(PFI)}$ ) of 1.15 V (typ), the  $\overline{PFO}$  goes low. If  $V_{IT(PFI)}$  goes above  $V_{(PFI)}$  plus about 12-mV hysteresis, the output returns to high. By connecting two external resistors, it is possible to supervise any voltages above  $V_{(PFI)}$ . The sum of both resistors should be about 1 M $\Omega$ , to minimize power consumption and also to ensure that the current in the PFI pin can be ignored, compared with the current through the resistor network. The tolerance of the external resistors should be not more than 1%, to ensure minimal variation of sensed voltage. If the power-fail comparator is unused, PFI should be connected to ground and  $\overline{PFO}$  left unconnected.

### Backup-Battery Switchover

In case of a brownout or power failure, it may be necessary to preserve the contents of RAM. If a backup battery is installed at  $V_{BAT}$ , the device automatically switches the connected RAM to backup power when  $V_{DD}$  fails. In order to allow the backup battery (e.g., a 3.6-V lithium cell) to have a higher voltage than  $V_{DD}$ , these supervisors do not connect  $V_{BAT}$  to  $V_{OUT}$  when  $V_{BAT}$  is greater than  $V_{DD}$ .  $V_{BAT}$  only connects to  $V_{OUT}$  (through a 15- $\Omega$  switch) when  $V_{DD}$  falls below the  $V_{IT}$  and  $V_{BAT}$  is greater than  $V_{DD}$ . When  $V_{DD}$  recovers, switchover is deferred, either until  $V_{DD}$  crosses  $V_{BAT}$  or until  $V_{DD}$  rises above  $V_{IT}$ .  $V_{OUT}$  connects to  $V_{DD}$  through a 1- $\Omega$  (max) PMOS switch when  $V_{DD}$  crosses the reset threshold.

**Table 2. FUNCTION TABLE**

$V_{DD} > V_{BAT}$	$V_{DD} > V_{IT}$	$V_{OUT}$
1	1	$V_{DD}$
1	0	$V_{DD}$
0	1	$V_{DD}$
0	0	$V_{BAT}$

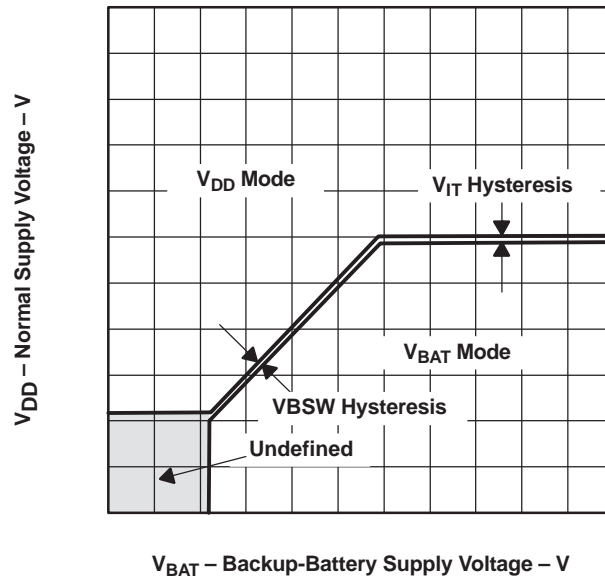

Figure 13. Normal Supply Voltage vs Backup-Battery Supply Voltage

**PACKAGING INFORMATION**

Orderable Device	Status (1)	Package Type	Package Drawing	Pins	Package Qty	Eco Plan (2)	Lead/Ball Finish (6)	MSL Peak Temp (3)	Op Temp (°C)	Device Marking (4/5)	Samples
TPS3619-33MDGKREP	ACTIVE	VSSOP	DGK	8	2500	Green (RoHS & no Sb/Br)	CU NIPDAU	Level-1-260C-UNLIM	-55 to 125	BZP	<a href="#">Samples</a>
TPS3620-33MDGKREP	ACTIVE	VSSOP	DGK	8	2500	Green (RoHS & no Sb/Br)	CU NIPDAU	Level-1-260C-UNLIM	-55 to 125	BTY	<a href="#">Samples</a>
TPS3620-33MDGKTEP	ACTIVE	VSSOP	DGK	8	250	Green (RoHS & no Sb/Br)	CU NIPDAU	Level-1-260C-UNLIM	-55 to 125	BTY	<a href="#">Samples</a>
V62/06670-01XE	ACTIVE	VSSOP	DGK	8	2500	Green (RoHS & no Sb/Br)	CU NIPDAU	Level-1-260C-UNLIM	-55 to 125	BZP	<a href="#">Samples</a>
V62/06670-03XE	ACTIVE	VSSOP	DGK	8	2500	Green (RoHS & no Sb/Br)	CU NIPDAU	Level-1-260C-UNLIM	-55 to 125	BTY	<a href="#">Samples</a>

(1) The marketing status values are defined as follows:

**ACTIVE:** Product device recommended for new designs.

**LIFEBUY:** TI has announced that the device will be discontinued, and a lifetime-buy period is in effect.

**NRND:** Not recommended for new designs. Device is in production to support existing customers, but TI does not recommend using this part in a new design.

**PREVIEW:** Device has been announced but is not in production. Samples may or may not be available.

**OBSOLETE:** TI has discontinued the production of the device.

(2) Eco Plan - The planned eco-friendly classification: Pb-Free (RoHS), Pb-Free (RoHS Exempt), or Green (RoHS & no Sb/Br) - please check <http://www.ti.com/productcontent> for the latest availability information and additional product content details.

**TBD:** The Pb-Free/Green conversion plan has not been defined.

**Pb-Free (RoHS):** TI's terms "Lead-Free" or "Pb-Free" mean semiconductor products that are compatible with the current RoHS requirements for all 6 substances, including the requirement that lead not exceed 0.1% by weight in homogeneous materials. Where designed to be soldered at high temperatures, TI Pb-Free products are suitable for use in specified lead-free processes.

**Pb-Free (RoHS Exempt):** This component has a RoHS exemption for either 1) lead-based flip-chip solder bumps used between the die and package, or 2) lead-based die adhesive used between the die and leadframe. The component is otherwise considered Pb-Free (RoHS compatible) as defined above.

**Green (RoHS & no Sb/Br):** TI defines "Green" to mean Pb-Free (RoHS compatible), and free of Bromine (Br) and Antimony (Sb) based flame retardants (Br or Sb do not exceed 0.1% by weight in homogeneous material)

(3) MSL, Peak Temp. - The Moisture Sensitivity Level rating according to the JEDEC industry standard classifications, and peak solder temperature.

(4) There may be additional marking, which relates to the logo, the lot trace code information, or the environmental category on the device.

(5) Multiple Device Markings will be inside parentheses. Only one Device Marking contained in parentheses and separated by a "~" will appear on a device. If a line is indented then it is a continuation of the previous line and the two combined represent the entire Device Marking for that device.

<sup>(6)</sup> Lead/Ball Finish - Orderable Devices may have multiple material finish options. Finish options are separated by a vertical ruled line. Lead/Ball Finish values may wrap to two lines if the finish value exceeds the maximum column width.

**Important Information and Disclaimer:**The information provided on this page represents TI's knowledge and belief as of the date that it is provided. TI bases its knowledge and belief on information provided by third parties, and makes no representation or warranty as to the accuracy of such information. Efforts are underway to better integrate information from third parties. TI has taken and continues to take reasonable steps to provide representative and accurate information but may not have conducted destructive testing or chemical analysis on incoming materials and chemicals. TI and TI suppliers consider certain information to be proprietary, and thus CAS numbers and other limited information may not be available for release.

In no event shall TI's liability arising out of such information exceed the total purchase price of the TI part(s) at issue in this document sold by TI to Customer on an annual basis.

**OTHER QUALIFIED VERSIONS OF TPS3619-33-EP, TPS3620-33-EP :**

- Catalog: [TPS3619-33](#), [TPS3620-33](#)

NOTE: Qualified Version Definitions:

- Catalog - TI's standard catalog product

**TAPE AND REEL INFORMATION**
**REEL DIMENSIONS**

**TAPE DIMENSIONS**

A0	Dimension designed to accommodate the component width
B0	Dimension designed to accommodate the component length
K0	Dimension designed to accommodate the component thickness
W	Overall width of the carrier tape
P1	Pitch between successive cavity centers

**TAPE AND REEL INFORMATION**

\*All dimensions are nominal

Device	Package Type	Package Drawing	Pins	SPQ	Reel Diameter (mm)	Reel Width W1 (mm)	A0 (mm)	B0 (mm)	K0 (mm)	P1 (mm)	W (mm)	Pin1 Quadrant
TPS3619-33MDGKREP	VSSOP	DGK	8	2500	330.0	12.4	5.3	3.4	1.4	8.0	12.0	Q1
TPS3620-33MDGKREP	VSSOP	DGK	8	2500	330.0	12.4	5.3	3.4	1.4	8.0	12.0	Q1
TPS3620-33MDGKTEP	VSSOP	DGK	8	250	177.8	12.4	5.3	3.4	1.4	8.0	12.0	Q1

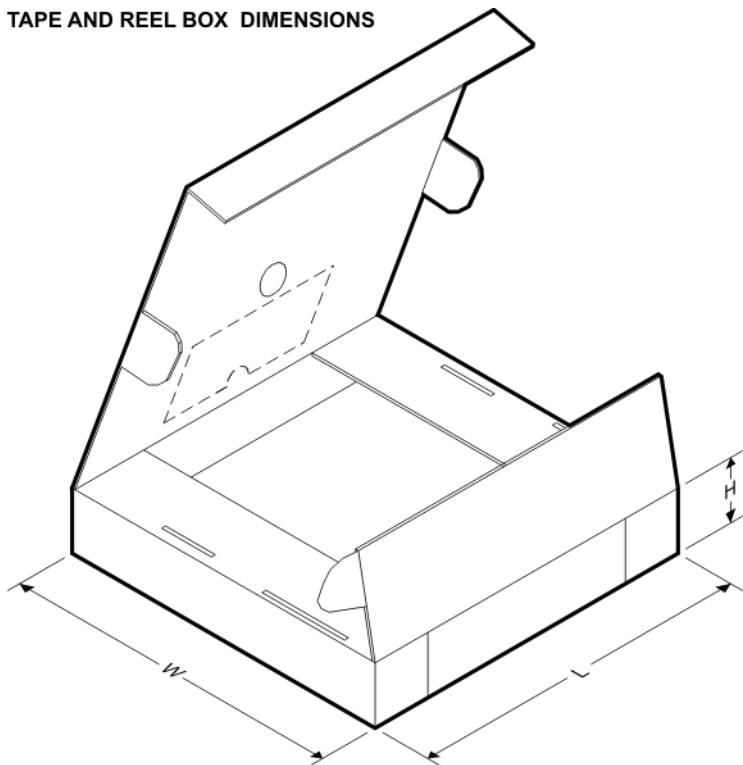
**TAPE AND REEL BOX DIMENSIONS**

\*All dimensions are nominal

Device	Package Type	Package Drawing	Pins	SPQ	Length (mm)	Width (mm)	Height (mm)
TPS3619-33MDGKREP	VSSOP	DGK	8	2500	358.0	335.0	35.0
TPS3620-33MDGKREP	VSSOP	DGK	8	2500	358.0	335.0	35.0
TPS3620-33MDGKTPEP	VSSOP	DGK	8	250	202.0	201.0	28.0



DGK (S-PDSO-G8)

PLASTIC SMALL-OUTLINE PACKAGE



- NOTES:
- A. All linear dimensions are in millimeters.
  - B. This drawing is subject to change without notice.
  - C. Body length does not include mold flash, protrusions, or gate burrs. Mold flash, protrusions, or gate burrs shall not exceed 0.15 per end.
  - D. Body width does not include interlead flash. Interlead flash shall not exceed 0.50 per side.
  - E. Falls within JEDEC MO-187 variation AA, except interlead flash.

## IMPORTANT NOTICE

Texas Instruments Incorporated and its subsidiaries (TI) reserve the right to make corrections, enhancements, improvements and other changes to its semiconductor products and services per JESD46, latest issue, and to discontinue any product or service per JESD48, latest issue. Buyers should obtain the latest relevant information before placing orders and should verify that such information is current and complete. All semiconductor products (also referred to herein as "components") are sold subject to TI's terms and conditions of sale supplied at the time of order acknowledgment.

TI warrants performance of its components to the specifications applicable at the time of sale, in accordance with the warranty in TI's terms and conditions of sale of semiconductor products. Testing and other quality control techniques are used to the extent TI deems necessary to support this warranty. Except where mandated by applicable law, testing of all parameters of each component is not necessarily performed.

TI assumes no liability for applications assistance or the design of Buyers' products. Buyers are responsible for their products and applications using TI components. To minimize the risks associated with Buyers' products and applications, Buyers should provide adequate design and operating safeguards.

TI does not warrant or represent that any license, either express or implied, is granted under any patent right, copyright, mask work right, or other intellectual property right relating to any combination, machine, or process in which TI components or services are used. Information published by TI regarding third-party products or services does not constitute a license to use such products or services or a warranty or endorsement thereof. Use of such information may require a license from a third party under the patents or other intellectual property of the third party, or a license from TI under the patents or other intellectual property of TI.

Reproduction of significant portions of TI information in TI data books or data sheets is permissible only if reproduction is without alteration and is accompanied by all associated warranties, conditions, limitations, and notices. TI is not responsible or liable for such altered documentation. Information of third parties may be subject to additional restrictions.

Resale of TI components or services with statements different from or beyond the parameters stated by TI for that component or service voids all express and any implied warranties for the associated TI component or service and is an unfair and deceptive business practice. TI is not responsible or liable for any such statements.

Buyer acknowledges and agrees that it is solely responsible for compliance with all legal, regulatory and safety-related requirements concerning its products, and any use of TI components in its applications, notwithstanding any applications-related information or support that may be provided by TI. Buyer represents and agrees that it has all the necessary expertise to create and implement safeguards which anticipate dangerous consequences of failures, monitor failures and their consequences, lessen the likelihood of failures that might cause harm and take appropriate remedial actions. Buyer will fully indemnify TI and its representatives against any damages arising out of the use of any TI components in safety-critical applications.

In some cases, TI components may be promoted specifically to facilitate safety-related applications. With such components, TI's goal is to help enable customers to design and create their own end-product solutions that meet applicable functional safety standards and requirements. Nonetheless, such components are subject to these terms.

No TI components are authorized for use in FDA Class III (or similar life-critical medical equipment) unless authorized officers of the parties have executed a special agreement specifically governing such use.

Only those TI components which TI has specifically designated as military grade or "enhanced plastic" are designed and intended for use in military/aerospace applications or environments. Buyer acknowledges and agrees that any military or aerospace use of TI components which have **not** been so designated is solely at the Buyer's risk, and that Buyer is solely responsible for compliance with all legal and regulatory requirements in connection with such use.

TI has specifically designated certain components as meeting ISO/TS16949 requirements, mainly for automotive use. In any case of use of non-designated products, TI will not be responsible for any failure to meet ISO/TS16949.

### Products

Audio	<a href="http://www.ti.com/audio">www.ti.com/audio</a>
Amplifiers	<a href="http://amplifier.ti.com">amplifier.ti.com</a>
Data Converters	<a href="http://dataconverter.ti.com">dataconverter.ti.com</a>
DLP® Products	<a href="http://www.dlp.com">www.dlp.com</a>
DSP	<a href="http://dsp.ti.com">dsp.ti.com</a>
Clocks and Timers	<a href="http://www.ti.com/clocks">www.ti.com/clocks</a>
Interface	<a href="http://interface.ti.com">interface.ti.com</a>
Logic	<a href="http://logic.ti.com">logic.ti.com</a>
Power Mgmt	<a href="http://power.ti.com">power.ti.com</a>
Microcontrollers	<a href="http://microcontroller.ti.com">microcontroller.ti.com</a>
RFID	<a href="http://www.ti-rfid.com">www.ti-rfid.com</a>
OMAP Applications Processors	<a href="http://www.ti.com/omap">www.ti.com/omap</a>
Wireless Connectivity	<a href="http://www.ti.com/wirelessconnectivity">www.ti.com/wirelessconnectivity</a>

### Applications

Automotive and Transportation	<a href="http://www.ti.com/automotive">www.ti.com/automotive</a>
Communications and Telecom	<a href="http://www.ti.com/communications">www.ti.com/communications</a>
Computers and Peripherals	<a href="http://www.ti.com/computers">www.ti.com/computers</a>
Consumer Electronics	<a href="http://www.ti.com/consumer-apps">www.ti.com/consumer-apps</a>
Energy and Lighting	<a href="http://www.ti.com/energy">www.ti.com/energy</a>
Industrial	<a href="http://www.ti.com/industrial">www.ti.com/industrial</a>
Medical	<a href="http://www.ti.com/medical">www.ti.com/medical</a>
Security	<a href="http://www.ti.com/security">www.ti.com/security</a>
Space, Avionics and Defense	<a href="http://www.ti.com/space-avionics-defense">www.ti.com/space-avionics-defense</a>
Video and Imaging	<a href="http://www.ti.com/video">www.ti.com/video</a>

### TI E2E Community

[e2e.ti.com](http://e2e.ti.com)