

Ceramic Disc Capacitors Class 2, Low Loss (0.2 %), 500 V_{DC}, 1 kV_{DC}, 2 kV_{DC} and 3 kV_{DC}

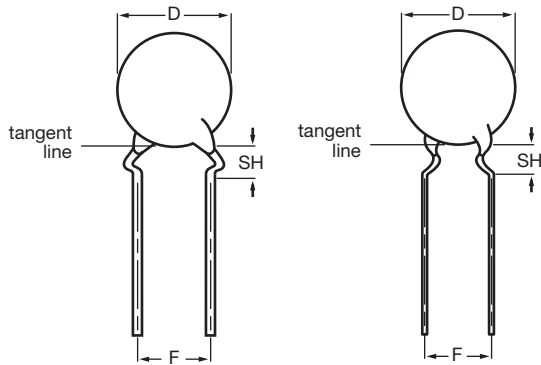

Capacitors with outside and inside kink lead spacing

QUICK REFERENCE DATA	
DESCRIPTION	CLASS 2 (Y5R)
Voltage (V _{DC})	500, 1000, 2000, 3000
Min. Capacitance (pF)	100
Max. Capacitance (pF)	4700
Mounting	Through hole

MARKING

Marking indicates capacitance value and tolerance in accordance with “EIA 198” and voltage marks.

OPERATING TEMPERATURE RANGE

- 30 °C to + 125 °C

TEMPERATURE COEFFICIENT Y5R (2C4)

- 30 °C TO + 85 °C

± 15 %

SECTIONAL SPECIFICATIONS

IEC 60384-9, EIA 198

EXAMPLES OF MARKING CODE

Disc size (D _{max.}) ≤ 6.5 mm:	Disc size (D _{max.}) ≥ 7.5 mm:
	BC
RP = low loss with T.C. Y5P	RP
101K	102K
2 kV	3 kV

Note

The capacitors meet the essential requirements of “IEC 60384-9 and EIA 198”. Unless stated otherwise all electrical values apply at an ambient temperature of 25 °C ± 3 °C, at normal atmospheric conditions

FEATURES

- High reliability
- Low losses
- High capacitance in small size
- Kinked leads
- Compliant to RoHS directive 2002/95/EC



RoHS
COMPLIANT

APPLICATIONS

In electronic circuits where low losses and high capacitance per volume are essential, for example:

- SMPS
- HF ballast
- Snubber and high voltage circuits

DESIGN

The capacitors consist of a ceramic disc both sides of which are silver-plated. Connection leads are made of tinned copper having a diameter of 0.6 mm or 0.8 mm.

The capacitors are supplied with kinked leads and lead spacings of 5 mm or 7.5 mm and 10 mm. Encapsulation is made of epoxy-resin, flammable resistant in accordance with “UL 94 V-0”

CAPACITANCE RANGE

100 pF to 4700 pF

RATED DC VOLTAGE

500 V; 1 kV; 2 kV; 3 kV

DIELECTRIC STRENGTH

200 % of rated voltage

INSULATION RESISTANCE AT 500 V_{DC}

≥ 10 000 MΩ min.

TOLERANCE ON CAPACITANCE

± 10 %; ± 20 %

DISSIPATION FACTOR

0.2 % max.

AGING

typical 0.5 % per time decade



Ceramic Disc Capacitors Class 2, Vishay BCcomponents
 Low Loss (0.2 %), 500 V_{DC}, 1 kV_{DC},
 2 kV_{DC} and 3 kV_{DC}

ORDERING INFORMATION							
C (pF)	TOL. (%)	D _{MAX.} (mm)	LEAD SPACING (mm)	SH ⁽¹⁾ (mm)	CLEAR TEXT CODE		
					13 TH DIGIT: T = REEL; U = AMMO; 3 = BULK 16 TH DIGIT: R = RoHS COMPLIANT		
500 V							
100	± 10	5.0	5.0	4.0	F101K20Y5RL6.J5.		
120					F121K20Y5RL6.J5.		
150					F151K20Y5RL6.J5.		
180					F181K20Y5RL6.J5.		
220					F221K20Y5RL6.J5.		
270					F271K20Y5RL6.J5.		
330					F331K20Y5RL6.J5.		
390		6.5	5.0		4.0	F391K25Y5RL6.J5.	
470						F471K25Y5RL6.J5.	
560						F561K25Y5RL6.J5.	
680						F681K25Y5RL6.J5.	
820						F821K29Y5RL6.J5.	
1000						F102K29Y5RL6.J5.	
500 V							
1200	± 10	8.5	5.0	4.0	F122K33Y5RL6.J5.		
1500		F152K33Y5RL6.J5.					
1800		F182K39Y5RL6.J5.					
2200		10.0	7.5		F222K39Y5RL6.J5.		
2700					F272K47Y5RL63J7.		
1 kV							
100	± 10	6.5	5.0	4.0	F101K25Y5RN6.J5.		
120					F121K25Y5RN6.J5.		
150					F151K25Y5RN6.J5.		
180					F181K25Y5RN6.J5.		
220					F221K25Y5RN6.J5.		
270		F271K29Y5RN6.J5.					
330		7.5			5.0	4.0	F331K29Y5RN6.J5.
390							F391K29Y5RN6.J5.
470							F471K29Y5RN6.J5.
560							F561K33Y5RN6.J5.
680			F681K33Y5RN6.J5.				
820		10.0	5.0		4.0	F821K39Y5RN6.J5.	
1000						F102K39Y5RN6.J5.	
1200						F122K43Y5RN6.J5.	
1500						F152K43Y5RN6.J5.	
1800						F182K47Y5RN63J7.	
2200		13.5	7.5		4.0	F222K53Y5RN63J7.	
2700						F272K53Y5RN63J7.	
3300						F332K69Y5RN63J7.	
3900						F392K69Y5RN63J7.	
4700	F472K75Y5RN83J0.						
2 kV							
100	± 10	6.5	5.0	4.0	F101K25Y5RP6.K5.		
120					F121K25Y5RP6.K5.		
150					F151K25Y5RP6.K5.		
180					F181K29Y5RP6.K5.		
220					F221K29Y5RP6.K5.		
270		7.5			5.0	4.0	F271K29Y5RP6.K5.
330							F331K29Y5RP6.K5.
390							F391K33Y5RP6.K5.
470							F471K33Y5RP6.K5.
560							F561K39Y5RP6.K5.

F Series



Vishay BCcomponents Ceramic Disc Capacitors Class 2,
Low Loss (0.2 %), 500 V_{DC}, 1 kV_{DC},
2 kV_{DC} and 3 kV_{DC}

ORDERING INFORMATION					
C (pF)	TOL. (%)	D _{MAX.} (mm)	LEAD SPACING (mm)	SH ⁽¹⁾ (mm)	CLEAR TEXT CODE
					13 TH DIGIT: T = REEL; U = AMMO; 3 = BULK 16 TH DIGIT: R = RoHS COMPLIANT
2 kV					
680	± 10	10.0	5.0	4.0	F681K39Y5RP6.K5.
820		11.0			F821K43Y5RP6.K5.
1000		12.0			F102K43Y5RP6.K5.
1200		7.5	13.5	4.8	F122K47Y5RP63K7.
1500					F152K53Y5RP63K7.
1800					F182K53Y5RP63K7.
2200					F222K69Y5RP63K7.
2700		17.5	10.0	F272K75Y5RP83K0.	
3300		19.0		F332K75Y5RP83K0.	
3900		24.5		F392K75Y5RP83K0.	
4700				F472K96Y5RP83K0.	
3 kV					
100	± 10	8.5	7.5	4.0	F101K33Y5RR6.K7.
120					F121K33Y5RR6.K7.
150					F151K33Y5RR6.K7.
180					F181K33Y5RR6.K7.
220					F221K33Y5RR6.K7.
270					F271K33Y5RR6.K7.
330					F331K33Y5RR6.K7.
390					F391K39Y5RR6.K7.
470					F471K39Y5RR6.K7.
560					10
680		11	F681K43Y5RR6.K7.		
820		13.5	F821K53Y5RR63K7.		
1000		15	F102K53Y5RR63K7.		
1200			F122K59Y5RR63K7.		
1500			F152K59Y5RR63K7.		
1800			F182K75Y5RR83K0.		
2200		19	10.0	F222K75Y5RR83K0.	
2700		21		F272K84Y5RR83K0.	

Notes

⁽¹⁾ SH = seated height

- Maximum thickness: 500 V = 3.5 mm; 1 kV = 4.5 mm; 2 kV = 5.0 mm; 3 kV = 6.0 mm

PACKAGING					
PACKAGING TYPE	SIZE CODE	LEAD SPACE (mm)	VOLTAGE (V _{DC})	SPQ	BOX DIMENSIONS L x W x H
Bulk (long lead L ≥ 25.4 mm)	20 to 25	all	all	1000	245 x 120 x 65
	29 to 39			1000	
	43 to 47			1000	
	53 to 75			500	
	84 to 96			250	
Tape and reel	≤ 47	≤ 6.4	< 500	2500	370 x 370 x 60
			500 ≤ WV ≤ 2000	2000	
			3000	1000	
	≥ 7.5	all	1000		
	≥ 53	all	all	1000	
Ammopack	≤ 47	≤ 6.4	< 500	2000	335 x 240 x 50
			500 ≤ WV < 2000	2000	335 x 290 x 50
			2000 and 3000	1500	
	≥ 53	all	all	1500	360 x 330 x 55
			all	1500	335 x 290 x 50

Note

- The capacitors are supplied in bulk packaging (cardboard boxes), in tape on reel or in ammpack

Ceramic Disc Capacitors Class 2, Vishay BCcomponents
 Low Loss (0.2 %), 500 V_{DC}, 1 kV_{DC},
 2 kV_{DC} and 3 kV_{DC}

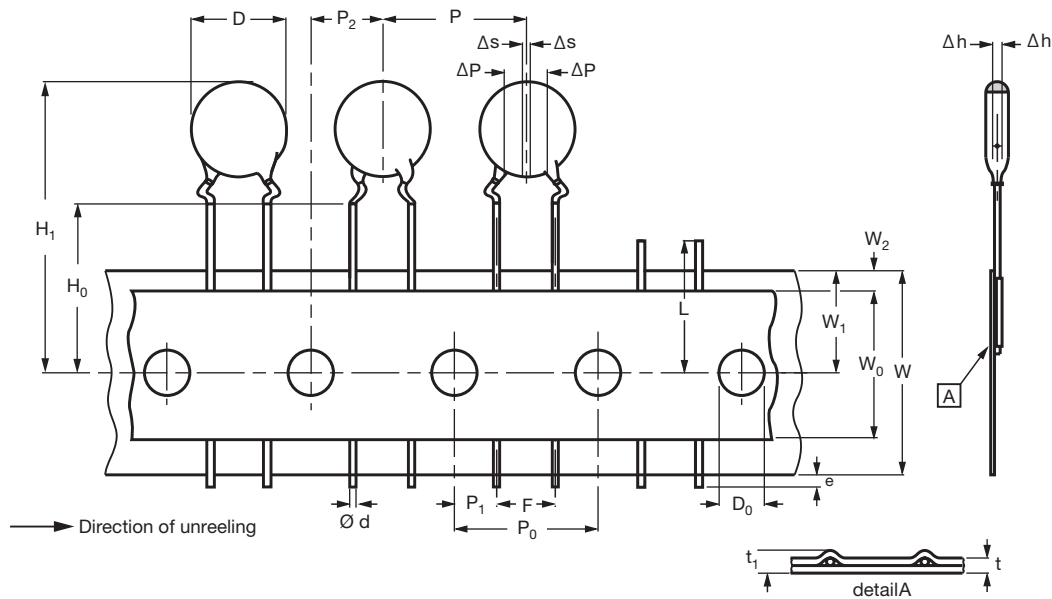

Kinked capacitors on tape, lead spacing 5.0 mm (0.2") or 7.5 mm (0.3")

DIMENSIONS OF TAPE			
SYMBOL	PARAMETER	DIMENSIONS (mm)	
		FEED-HOLE PITCH $P_0 = 12.7$	FEED-HOLE PITCH $P_0 = 15.0$
D	Body diameter	11.0 max.	14.0 max.
d	Lead diameter	0.6 ± 0.05	0.6 ± 0.05
P ⁽¹⁾	Pitch between capacitors	12.7 ± 1.0	15.0 ± 1.0
P ₀	Feed-hole pitch	12.7 ± 0.3	15.0 ± 0.3
ΔP	Plane deviation	1.0 max.	1.0 max.
P ₁ ⁽²⁾	Feed-hole center to lead center	3.85 ± 0.7	3.75 ± 0.7
P ₂ ⁽²⁾	Feed-hole center to component center	6.35 ± 1.3	7.5 ± 1.5
F	Lead spacing	$5.0 + 0.6/- 0.4$	$7.5 + 0.6/- 0.4$
Δh	Component alignment	0 ± 1.0	0 ± 1.0
W	Tape width	$18.0 + 1.0/- 0.5$	$18.0 + 1.0/- 0.5$
W ₀	Hold-down tape width	5.0 min.	5.0 min.
W ₁	Hole position	$9.0 + 0.75/- 0.5$	$9.0 + 0.75/- 0.5$
W ₂	Hold-down tape margin	3.0 max.	3.0 max.
H ₀	Height to seating plane	16.0 ± 0.5	16.0 ± 0.5
H ₁	Maximum component height	32.0	40.0
e	Lead end protrusion	1.0 max.	1.0 max.
L	Maximum length of snipped lead	11.0	11.0
D ₀	Feed-hole diameter	4.0 ± 0.2	4.0 ± 0.2
t	Total tape thickness	0.9 max.	0.9 max.
t ₁	Maximum thickness of tape and wires	1.5 max.	1.5 max.

Notes

⁽¹⁾ Cumulative pitch error: $\pm \leq 1 \text{ mm}/20 \text{ pitches}$

⁽²⁾ Obliquity maximum 3°

F Series



Vishay BCcomponents Ceramic Disc Capacitors Class 2,
 Low Loss (0.2 %), 500 V_{DC}, 1 kV_{DC},
 2 kV_{DC} and 3 kV_{DC}

REEL AND TAPE DATA in millimeters

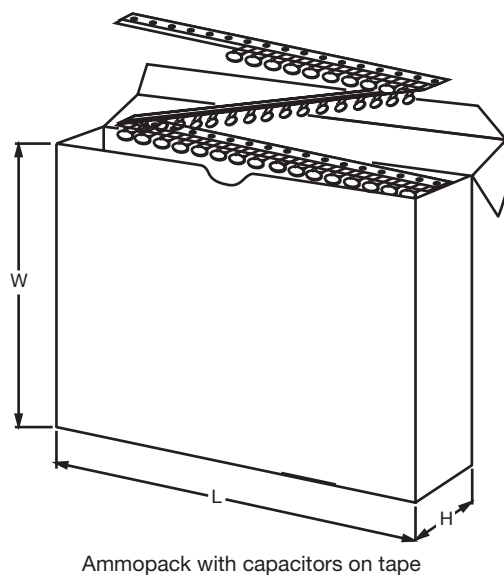
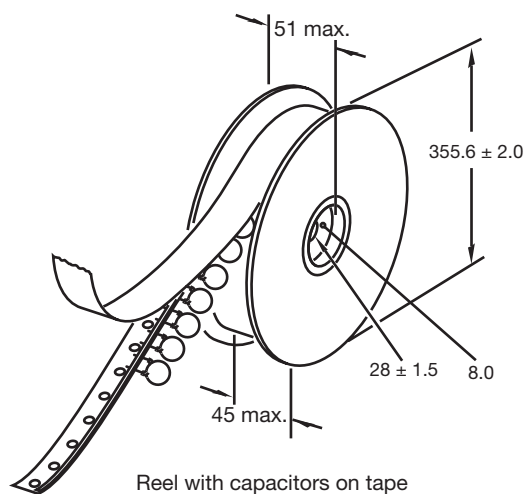

DIMENSIONS OF AMMOPACK			
PARAMETER	DISC SIZE (D _{MAX.})		UNIT
	6.5 mm to 11.0 mm	12.0 mm to 13.5 mm	
Taping pitch	12.7	15.0	mm
L	335	360	mm
W	290	330	mm
H	50	55	mm



Ceramic Disc Capacitors Class 2, Vishay BCcomponents
Low Loss (0.2 %), 500 V_{DC}, 1 kV_{DC},
2 kV_{DC} and 3 kV_{DC}

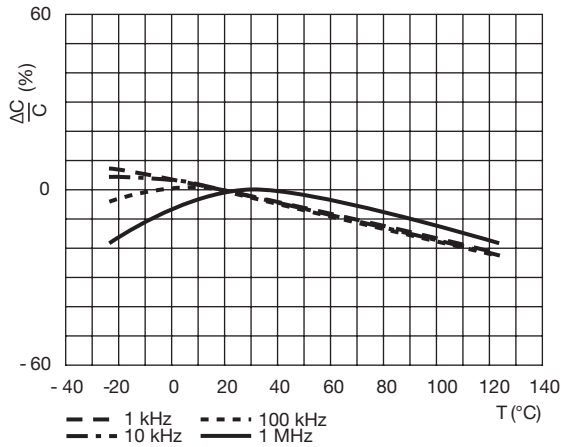

Typical capacitance change as a function of temperature and frequency

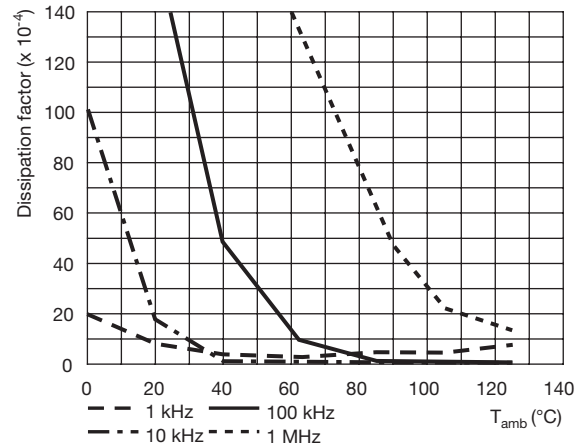

Typical dissipation factor as a function of temperature and frequency

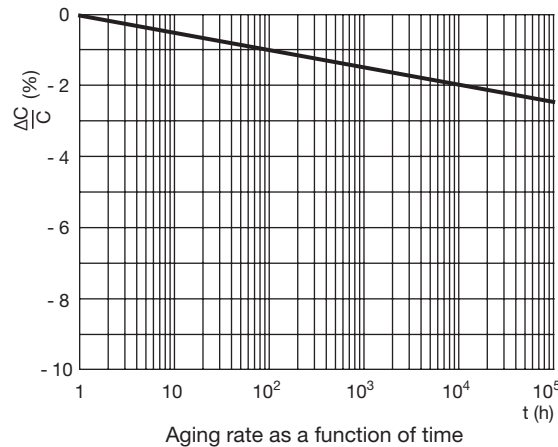

Aging rate as a function of time



Disclaimer

ALL PRODUCT, PRODUCT SPECIFICATIONS AND DATA ARE SUBJECT TO CHANGE WITHOUT NOTICE TO IMPROVE RELIABILITY, FUNCTION OR DESIGN OR OTHERWISE.

Vishay Intertechnology, Inc., its affiliates, agents, and employees, and all persons acting on its or their behalf (collectively, "Vishay"), disclaim any and all liability for any errors, inaccuracies or incompleteness contained in any datasheet or in any other disclosure relating to any product.

Vishay makes no warranty, representation or guarantee regarding the suitability of the products for any particular purpose or the continuing production of any product. To the maximum extent permitted by applicable law, Vishay disclaims (i) any and all liability arising out of the application or use of any product, (ii) any and all liability, including without limitation special, consequential or incidental damages, and (iii) any and all implied warranties, including warranties of fitness for particular purpose, non-infringement and merchantability.

Statements regarding the suitability of products for certain types of applications are based on Vishay's knowledge of typical requirements that are often placed on Vishay products in generic applications. Such statements are not binding statements about the suitability of products for a particular application. It is the customer's responsibility to validate that a particular product with the properties described in the product specification is suitable for use in a particular application. Parameters provided in datasheets and / or specifications may vary in different applications and performance may vary over time. All operating parameters, including typical parameters, must be validated for each customer application by the customer's technical experts. Product specifications do not expand or otherwise modify Vishay's terms and conditions of purchase, including but not limited to the warranty expressed therein.

Except as expressly indicated in writing, Vishay products are not designed for use in medical, life-saving, or life-sustaining applications or for any other application in which the failure of the Vishay product could result in personal injury or death. Customers using or selling Vishay products not expressly indicated for use in such applications do so at their own risk. Please contact authorized Vishay personnel to obtain written terms and conditions regarding products designed for such applications.

No license, express or implied, by estoppel or otherwise, to any intellectual property rights is granted by this document or by any conduct of Vishay. Product names and markings noted herein may be trademarks of their respective owners.