

HIP9011EVAL1Z Evaluation Board

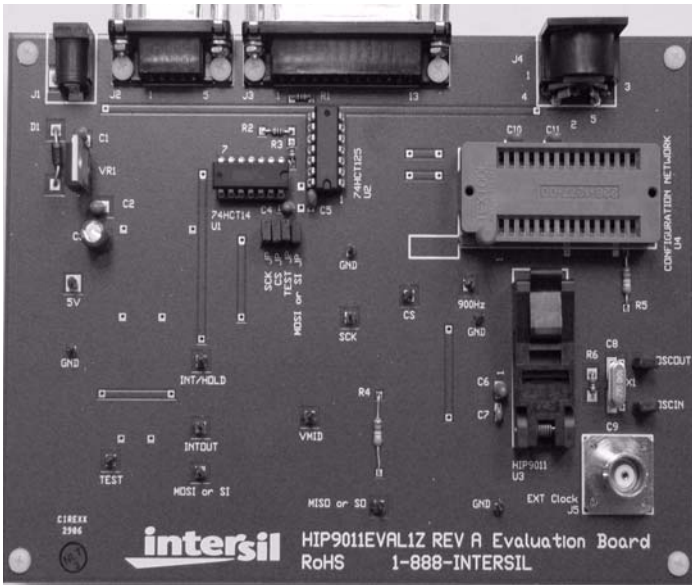

There continues a driving effort by the Government and the automotive industry to make cars more efficient with lower emissions. Tighter and more extensive control of automobile engines by microcontrollers has resulted in significant strides towards these goals.

One of the factors contributing to these improvements is engine ignition control. The HIP9011 helps in the ongoing battle to enhance engine performance by providing more detailed information to the engine microcontroller.

An important point to remember - automotive engines operate most efficiently when the engine is placed in the ignition timing condition just prior to ping or pre-ignition. The closer an engine can operate to this condition, the higher the performance. This is analogous to an operational amplifier, where the higher the gain, the lower the distortion. In the case of the knock signal processing IC, it provides a means of detecting engine knock or ping at levels that were previously unrealizable by amplification and filter means. Figure 1 shows the HIP9011 in a typical engine application.

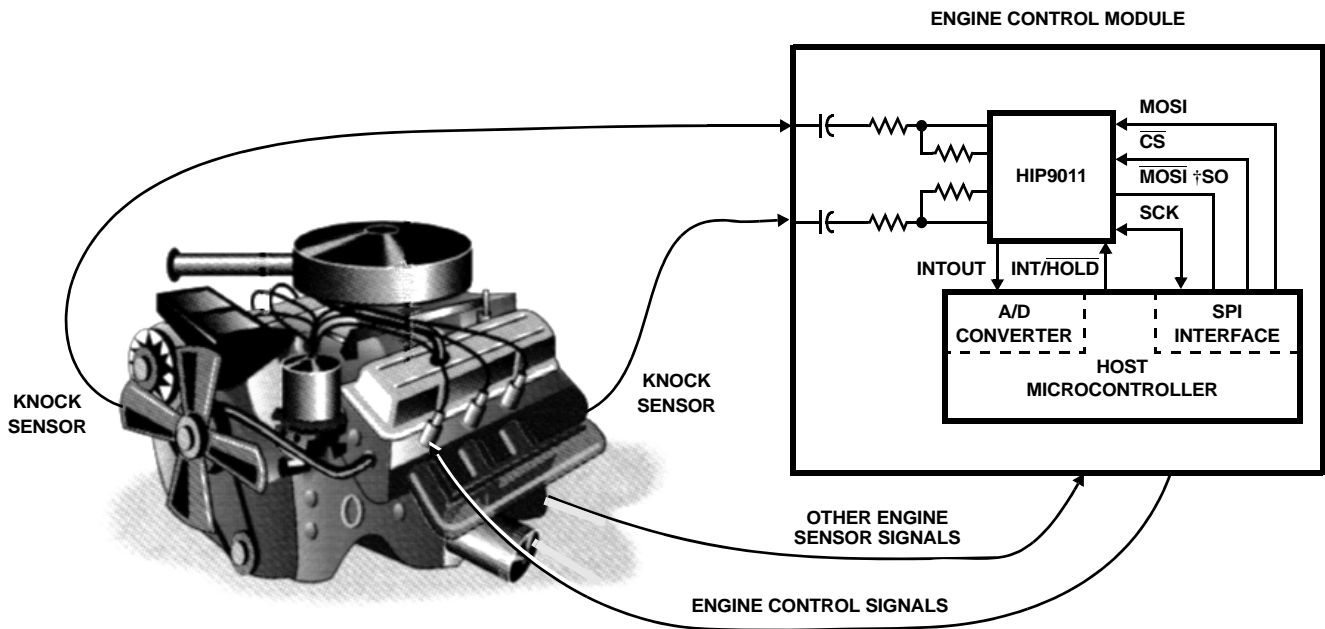

FIGURE 1. HIP9011 IN A TYPICAL ENGINE CONTROL APPLICATION

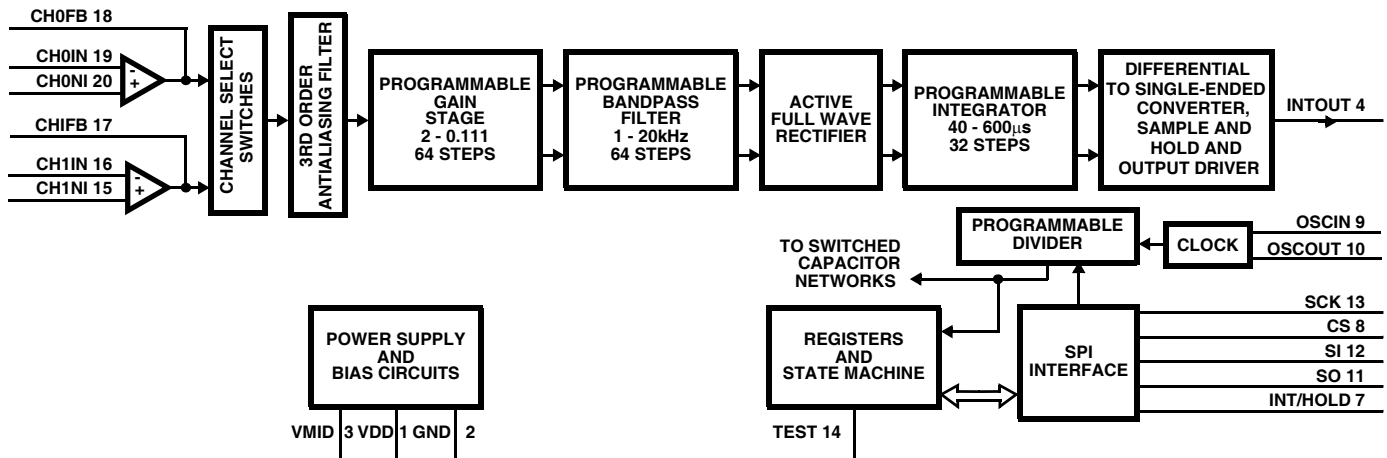

FIGURE 2. SIMPLIFIED BLOCK DIAGRAM OF THE HIP9011, SINGLE CHANNEL KNOCK SIGNAL PROCESSING IC

Operation of the Signal Processing IC

Inputs from one or two piezoelectric sensors mounted on the engine block are capacitively coupled to the inputs of the operational amplifiers within the HIP9011. Two sensors are shown in the examples in this application note, one for each side of a “V” type of engine configuration. Engines configured in-line may use sensors placed on either end of the engine block. Often only one sensor is used by strategically locating a point where optimum signal output is available. The ability of this IC to have programmable gain changes at each ignition pulse can help with these configurations. In some high end applications two HIP9011 are used.

The input coupling capacitor and series input resistors to the inverting input of the operational amplifiers within the HIP9011 serve as a high pass filter to reduce low frequency components from the transducer. AC coupling also has the advantage of reducing the possibility of driving the output of the input amplifier towards the positive supply with increased leakage resistance of the transducer or environment with time. Leakage resistance to ground will pull the inverting input of the operational amplifier to ground, thus forcing its output high. The non-inverting input of the HIP9011 is not committed, but in most applications, it is usually returned to the mid supply voltage, available as an output terminal of the device.

A signal from the engine’s microcontroller determines which transducer input signal will be processed by the HIP9011 operational amplifier for each ignition pulse by toggling the transmission gate on the output of these amplifiers. From here the signal is applied to an anti aliasing filter within the HIP9011. This filter excludes input signals above 20kHz from passing on to the following switched capacitor filter and gain stages. Signals above 20kHz could cause problems with the 200kHz clocking frequency of the switched capacitor filters and amplifiers. A filter channel is provided in the HIP9011, with a tuning range from 1.22kHz to 19.98kHz, in 64 steps. Serial control signals are sent via the SPI bus to the HIP9011 by the microcontroller. These control signals set the filter frequencies within these ICs.

The output of the Filter Stage in the HIP9011 is applied to a full wave rectifier and then to an integrator. The integrator operation is initiated by the INT/HOLD signal from the microcontroller. It is only during the rising edge of the INT/HOLD signal that the integrator starts from its initial reset condition of 0.125V. Integration is towards the positive supply when a knock signal is present. Severity of the knock signal and the integrators programmable time constant determines the final level. The integrator time constant is programmable in 32 steps from 40µs to 600µs. This time constant can be viewed as an output signal attenuator. Again, the value of the time constant is set by the SPI control signals from the microcontroller.

Immediately after the INT/HOLD signal goes low, the integrators output signal, INTOUT is held in the HIP9011’s output sample and hold circuit for the microcontroller’s A/D converter to process. Figure 2 shows the block diagram of the HIP9011. Figure 3 shows the waveforms for the integrator, INTOUT on the top trace. The center trace shows the input signal from a simulated pressure transducer mounted on the cylinder. An expanded waveform of the simulated engine input signal during the integration period is shown in the circled display of Figure 3. The bottom trace shows the INT/HOLD signal.

From this discussion we see that we have an IC that can detect low levels of engine knock or ping by using bandpass filters, rectification and an integration process. The gated integrator allows the IC to only monitor engine noise during the time that engine knock is expected to occur, thus, vastly reducing the influence of background noise.

Integrator Operation

Observation of the integrator output signal, INTOUT, is important to the setup and understanding of the operation of this signal processing IC. This observation can be distorted by instrumentation used to view the INTOUT signal. In Figure 5, the upper waveform shows what looks like inaccuracies in the INTOUT signal. This is due to aliasing of the oscilloscope sampling system with only 500 samples. Not shown in this

display is the 200kHz clock signal that only appears during the integration portion of the sample cycle. This signal causes aliasing or a “low frequency beat” in the oscilloscope display between the 500 samples and the 200kHz pulses appearing on the ramp only during the integration interval. Once the signal is acquired, the INTOUT signal during the hold period remains constant and free of the 200kHz pulses until the next integration period. The sample and hold circuit within the HIP9011 is timed so that it only samples during a non pulse period, thus preventing it from acquiring either peaks or valleys.

The lower trace of Figure 5 more accurately depicts the INTOUT waveform. Note the 200kHz clock signal on the integrator ramp. One million samples were used for this display. Also note that INTOUT is constant between integration cycles and shows no 200kHz pulses.

For observation purposes only, or when working with a digital oscilloscope with limited samples, an external anti aliasing filter may be assembled with a series 51k resistor and a 510pF capacitor to ground. The filter attenuates the internal 200kHz clock signal during integration. For operation with a sampling A/D converter that is strobed and samples after the integration cycle, no filter is needed.

Laboratory Setup

It is desirable to get a “feeling” for the operation of the HIP9011 before proceeding to an evaluation with an engine, Figure 6 shows a bench test setup where this can be easily accomplished.

One generator is used to provide the INT/HOLD signal to the Evaluation Board. In the actual application this signal would be supplied by the engine controller. The width of this signal may vary from several hundred microseconds to several milliseconds depending upon the engine rpm and engine type. Generally, there is a large signal at high engine rpms and lower signals at low rpms. At the lower rpm, the integration period may be extended to gain more samples and effectively produce high sensitivity to obtain more output.

The second generator provides the signal that serves as a knock signal. It is interesting to note the variation of the integrator output, INTOUT, as the IC filter frequency or oscillator frequency is varied from 200Hz to 100kHz. Figure 4 shows the IC’s filter response as a sweep frequency signal is applied to only the filter circuit for five selected filter frequencies from 1.22kHz to 19.98kHz. These curves were taken only of the filters to show their response and comparatively constant output through out the entire filter frequency range.

Figure 7 shows the HIP9011 connected to an engine. The microcontroller with inputs from the engine, provides the INT/HOLD signal to initiate operation of the integrator within the knock signal processing IC.

Evaluation Board

Figure 8 shows the schematic diagram of the evaluation board. A 4MHz crystal is supplied with the board. 4MHz ceramic resonators such as the TDK FRC4.0MCS have been successfully used in the board. Three pins are provided on the board to accept resonators to replace the crystal.

A prewired input amplifier configuration board is provided as shown in Figure 9. This board is connected for single ended operation.

Figure 10 shows the schematic diagram for a differential input board that may be wired for the HIP9011. This may be fabricated with the one generic blank board supplied with the evaluation board.

Figure 11 is a top view of the evaluation board.

Software Displays

Figure 12 shows the display for the HIP9011 appearing on the computer when using the Evaluation Board in a Microsoft® Windows® setup. In some Windows setups the text displayed may override the boxes and be difficult to read due to computer settings. This can be corrected by changing the font size on the computer. This is described in the “Installing Knock Signal Processor Software” section of this application note.

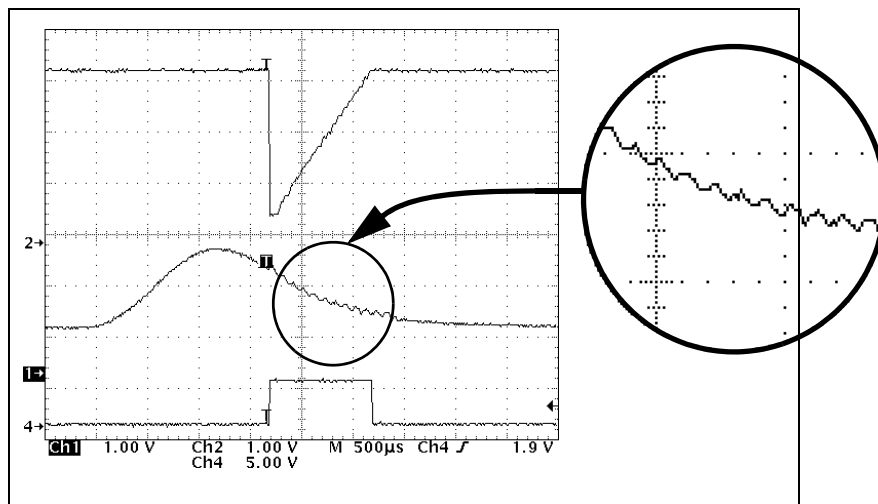

FIGURE 3. WAVEFORMS ASSOCIATED WITH THE HIP9011

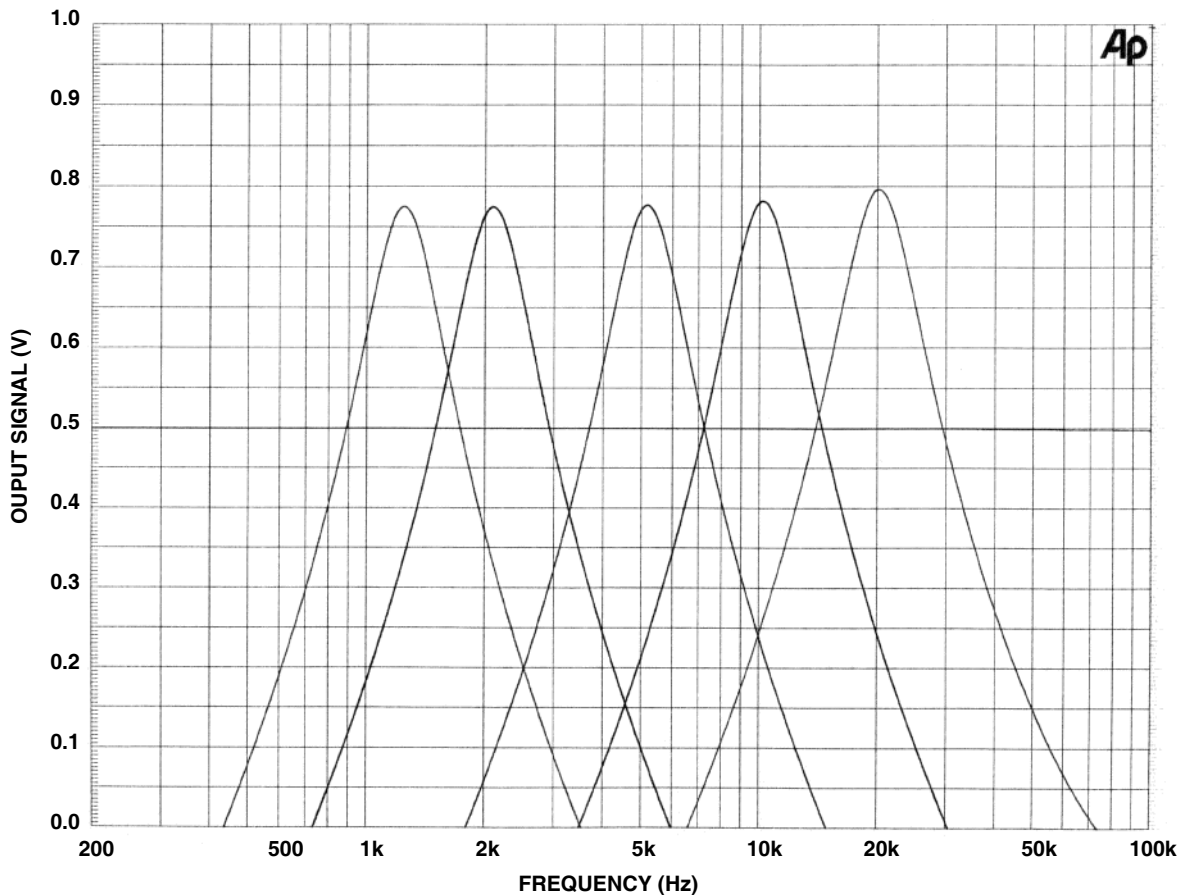

FIGURE 4. RESPONSE OF ONLY THE FILTERS WITHIN THE HIP9011

The codes written by the computer for each function are displayed on the lower right side of the display. Multiple settings may easily be obtained by opening more windows with different settings and clicking with the mouse on the desired window, to activate the desired setting.

Figure 13 through Figure 17 shows the writing sequence to the knock processing IC by the computer for various settings of the knock signal processing ICs.

Open Knock Sensor Detection

One means to detect an open sensor is to couple a low level, low frequency AC signal to the amplifier input. If the coupling capacitor value carrying this signal is small compared to the capacitance of the piezoelectric transducer, the coupled signal will be attenuated. To a first order, this would be the capacitance ratio $C_{coupling}/C_{sensor}$. Moreover, if the low level signal's frequency is below the normal spectrum of engine signals it will be further attenuated by the bandpass filters. To accomplish this function on the Evaluation Board, two terminals are provided. One is marked 900Hz, while the other is the ground return for that signal. When the piezoelectric transducer is removed from the input circuit, the previously attenuated 900Hz signal will become large and drive the IC's input operational amplifier to full output, which will produce higher frequency components that will

look like a severe knock signal that can not be handled by the control system. Software would then retard the timing to a minimum that would allow the engine to function, but at a lower efficiency level. Service would be required to restore normal engine operation.

Another Open Knock Sensor Approach with a Software Algorithm

The main focus of this method to detect sensor disconnect is based on exploiting the re-programmability of the gain stage within the IC. If a user reprograms the gain stage, for example, at every 5th engine revolution for an open sensor condition, the response time and accuracy of the feedback knock sensor control should not impair the engine performance over most of the entire engine speed range.

The approach is to adjust the GAIN stage prior to supplying the knock signal to the Band Pass Filter stage. To determine the sensor disconnect threshold value for the knock sensor system, the gain would be reduced to the lowest programmable level. This would then provide a signal level/reference value closest to that produced by a sensor that was disconnected.

Then with the GAIN stage programmed to a more normal/frequent operating value, should a sensor become disconnected, the INTOUT signal level would drop to a level

near the level/value that was determined when the GAIN stage was set at the lowest value of gain. From this higher gain value/operating condition, the system could then determine that the sensor has been disconnected.

Another approach that has been suggested is to, at engine start up, advance the engine timing to the knock level and observe the INTOUT signal. If knock cannot be detected, the sensor is assumed open.

Application Tips

Here are several important points about the application of the HIP9011 that will enhance the performance of a system using this IC. First, as mentioned previously, it is suggested that a coupling capacitor be placed in series with the transducer. This minimizes the possibility of pulling the inverting input of the operational amplifiers within the IC to ground. Grounding the inverting input forces the amplifier output high, thus limiting the signal handling ability of the amplifiers.

Another important point is to insure that the input amplifier and following stages operate at near their maximum peak to peak signal level without overload under the maximum expected input. Doing this allows the integrator stage to be set to lower gain settings, larger time constants, and thus reduces sensitivity in the output stage. This is analogous to a public address amplifier where the master gain control, analogous to the integrator stage, is set to full gain and the input gain control set to minimum gain. Under these conditions the public system will be noisy.

As a goal keep the output of the input operational amplifiers within half of the maximum expected output swing. This will insure that the following analog initializing filter has sufficient dynamic range. The switched capacitor gain stage can be used to either attenuate or amplify the signal. By observing these conditions, the signal going into the integrator stage will usually require a large time constant to keep the integrator from saturating. Also, remember that the effective system gain can be increased by increasing the integration window when higher gain is needed, usually, at lower engine speeds.

Other Applications

Because of the extremely unique design of this signal processing IC with over 130,000 programming combinations, the user is afforded maximum flexibility of signal detection and processing. Other applications are possible such as security systems with acoustical spectrum analysis with the aid of the filter within this device. Room, area or system profiles can be stored and compared with current values.

Analysis of heavy transmissions or other machinery with sensors used to detect bearing wear and other acoustical qualities is possible. Here preventive maintenance would be one of the key qualities.

Application Note 9770

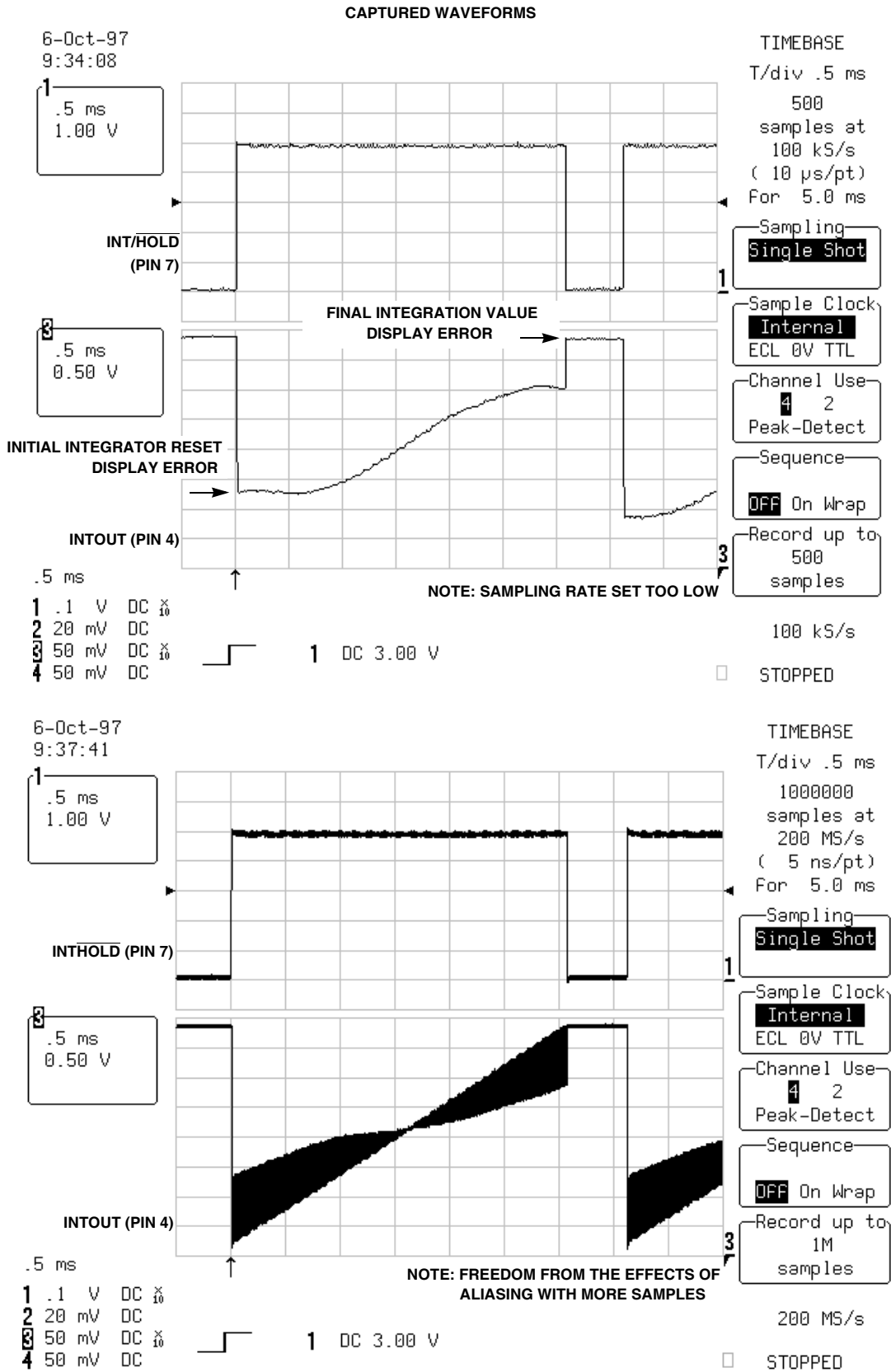

FIGURE 5. INTOUT (PIN 4) OUTPUT WAVEFORM DISPLAY INACCURACIES DUE TO DIGITAL SAMPLING SCOPE SETTINGS

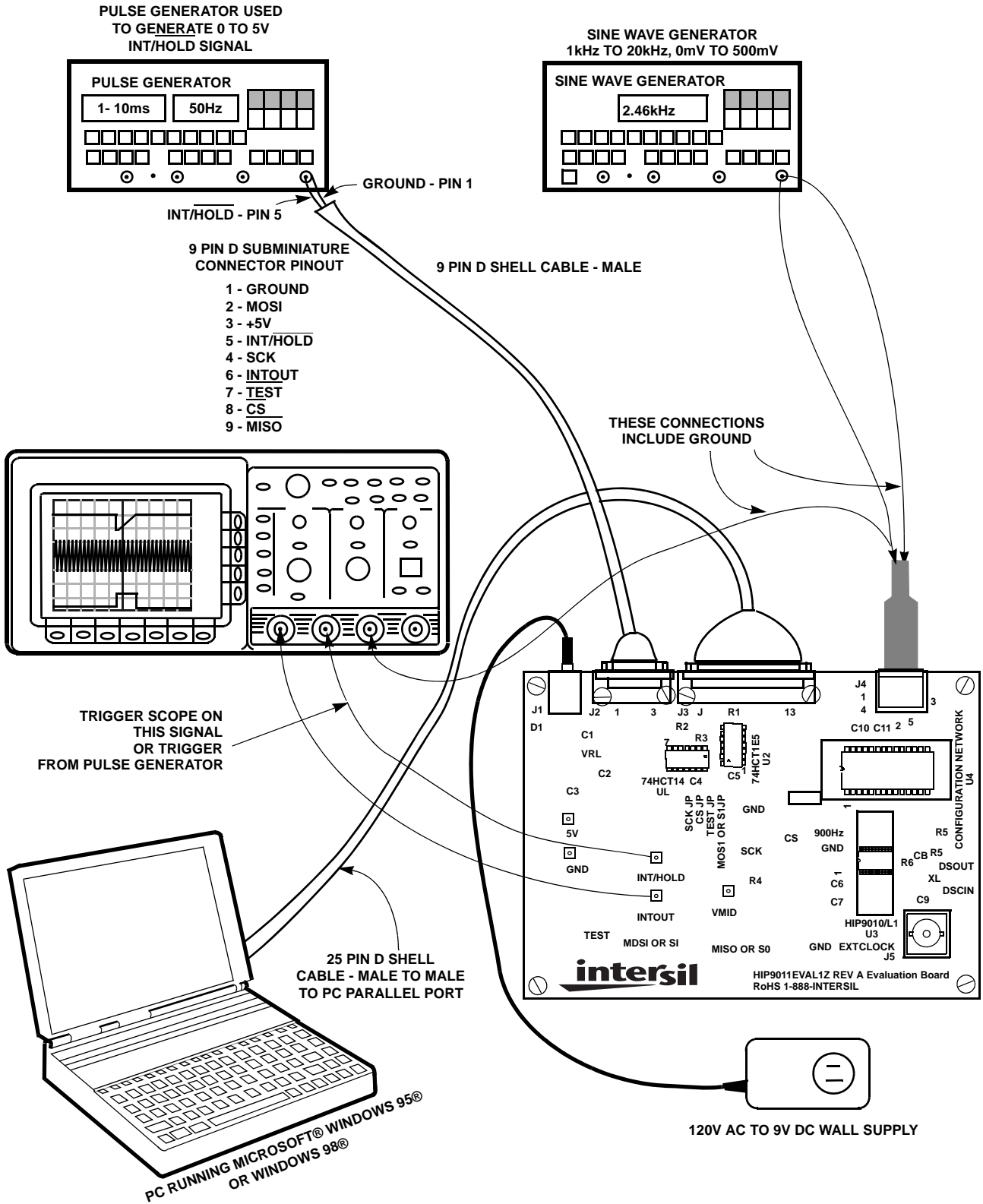

FIGURE 6. KNOCK SENSOR IC EVALUATION BOARD CONNECTIONS FOR BENCH TESTING

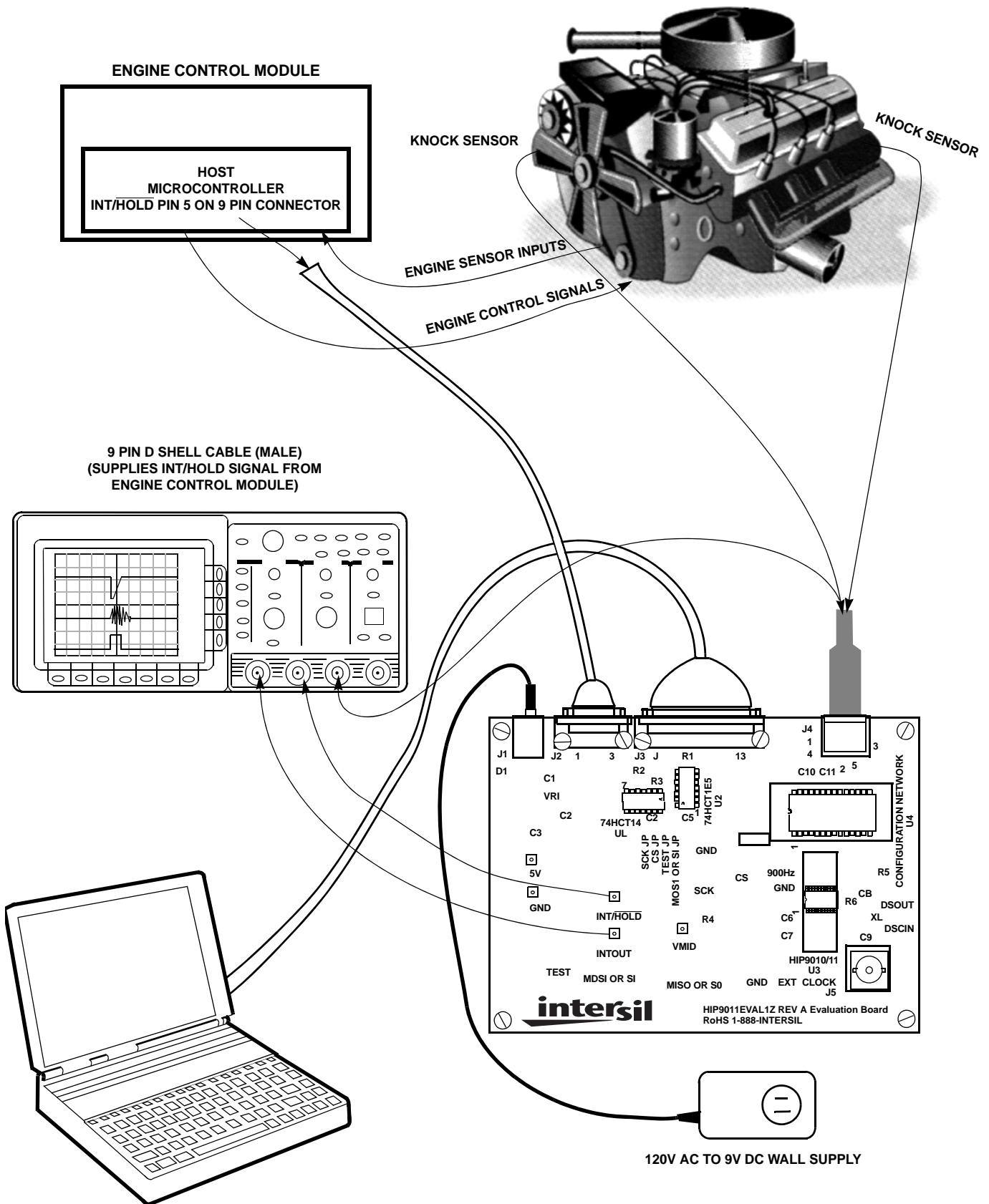

FIGURE 7. KNOCK SENSOR IC EVALUATION BOARD CONNECTIONS FOR TESTING WITH AN ENGINE

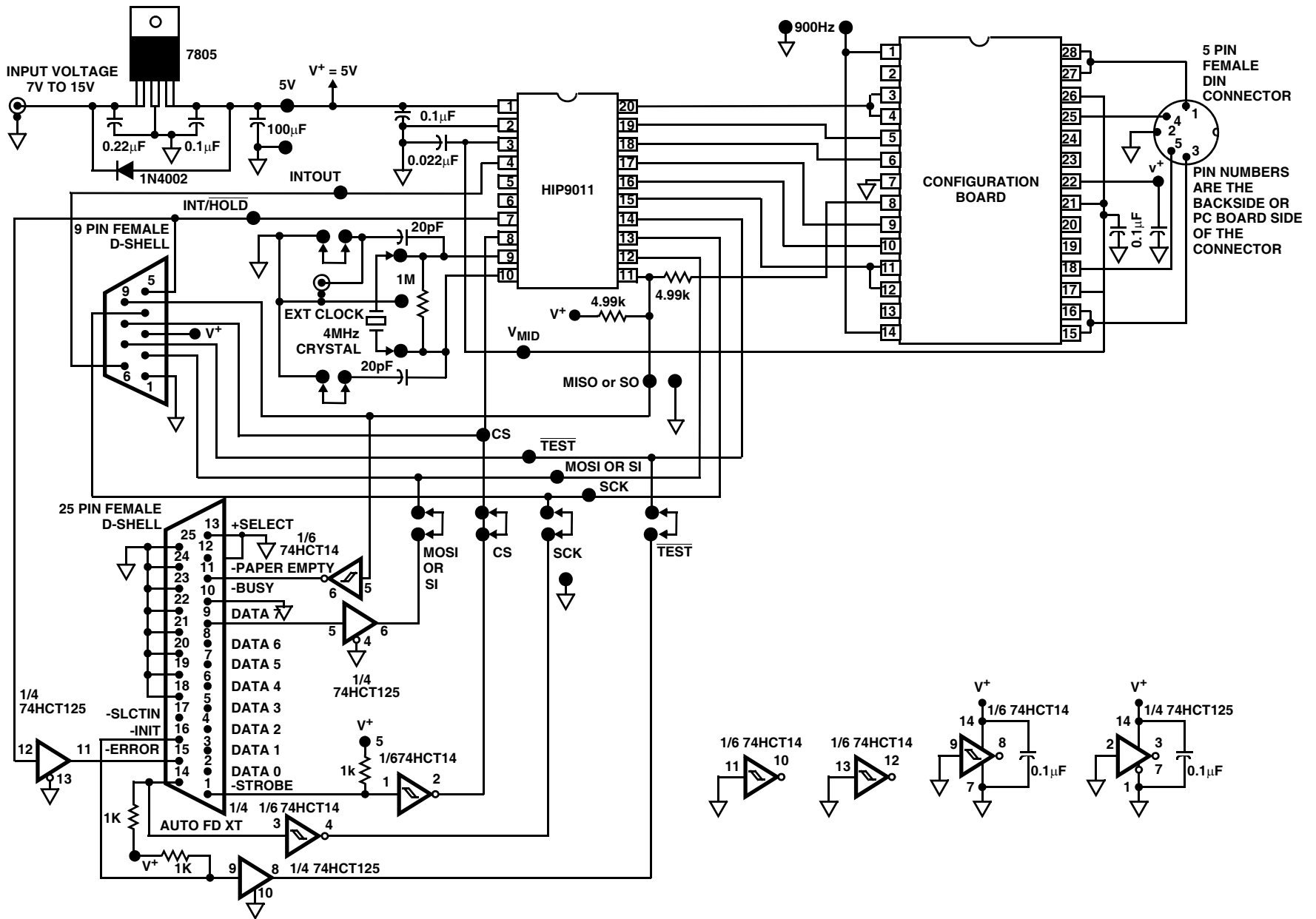

FIGURE 8. HIP9011 EVALUATION BOARD SCHEMATIC DIAGRAM

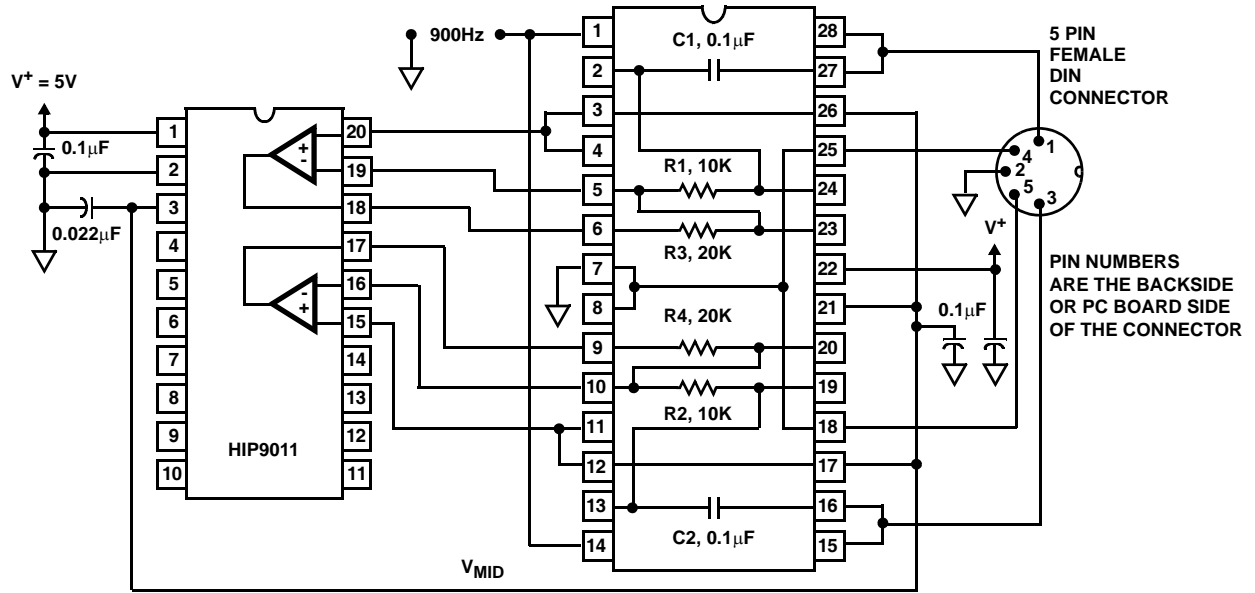
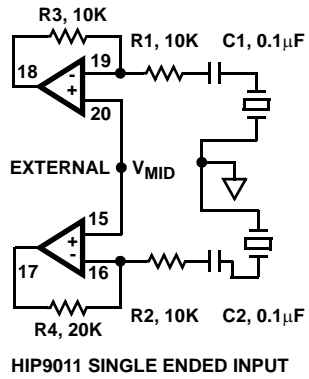
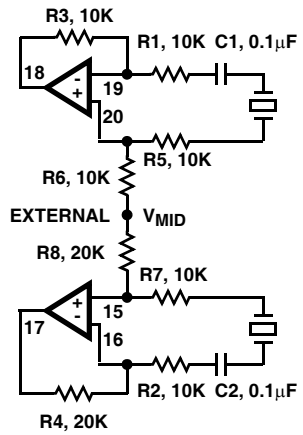
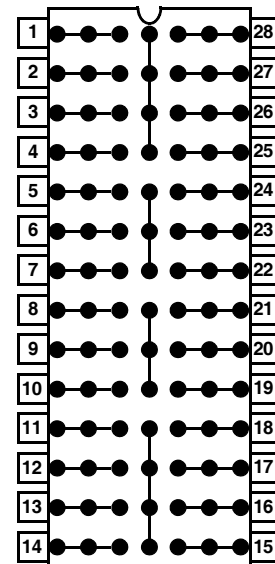
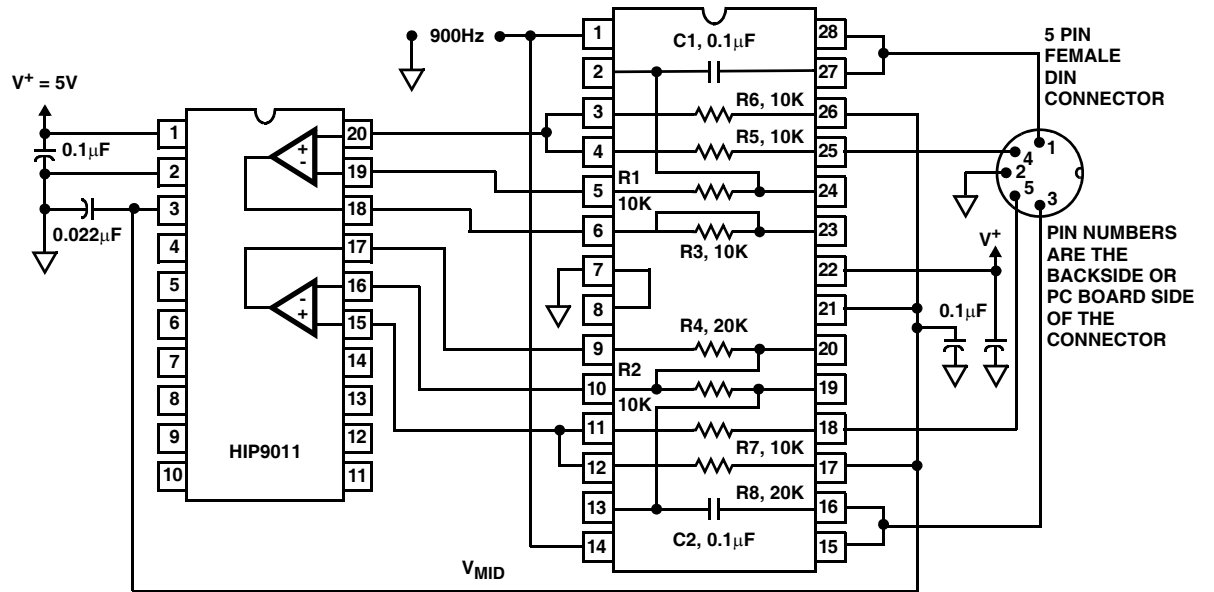

FIGURE 9. SCHEMATIC AND FUNCTIONAL DIAGRAMS OF THE HIP9011 SINGLE-ENDED CONFIGURATION BOARD (HIP9011CONFIG1Z)



HIP9011 DIFFERENTIAL INPUT

†HIP9011 DIFFERENTIAL BOARD NOT SUPPLIED



HIP9011 GENERIC CONFIGURATION BOARD (HIP9011_28DIP1Z)

NOTE: Generic configuration board for end-users custom differential input amplifier designs.

FIGURE 10. SCHEMATIC AND FUNCTIONAL DIAGRAMS OF THE HIP9011 GENERIC CONFIGURATION BOARD (HIP9011_28DIP1Z)

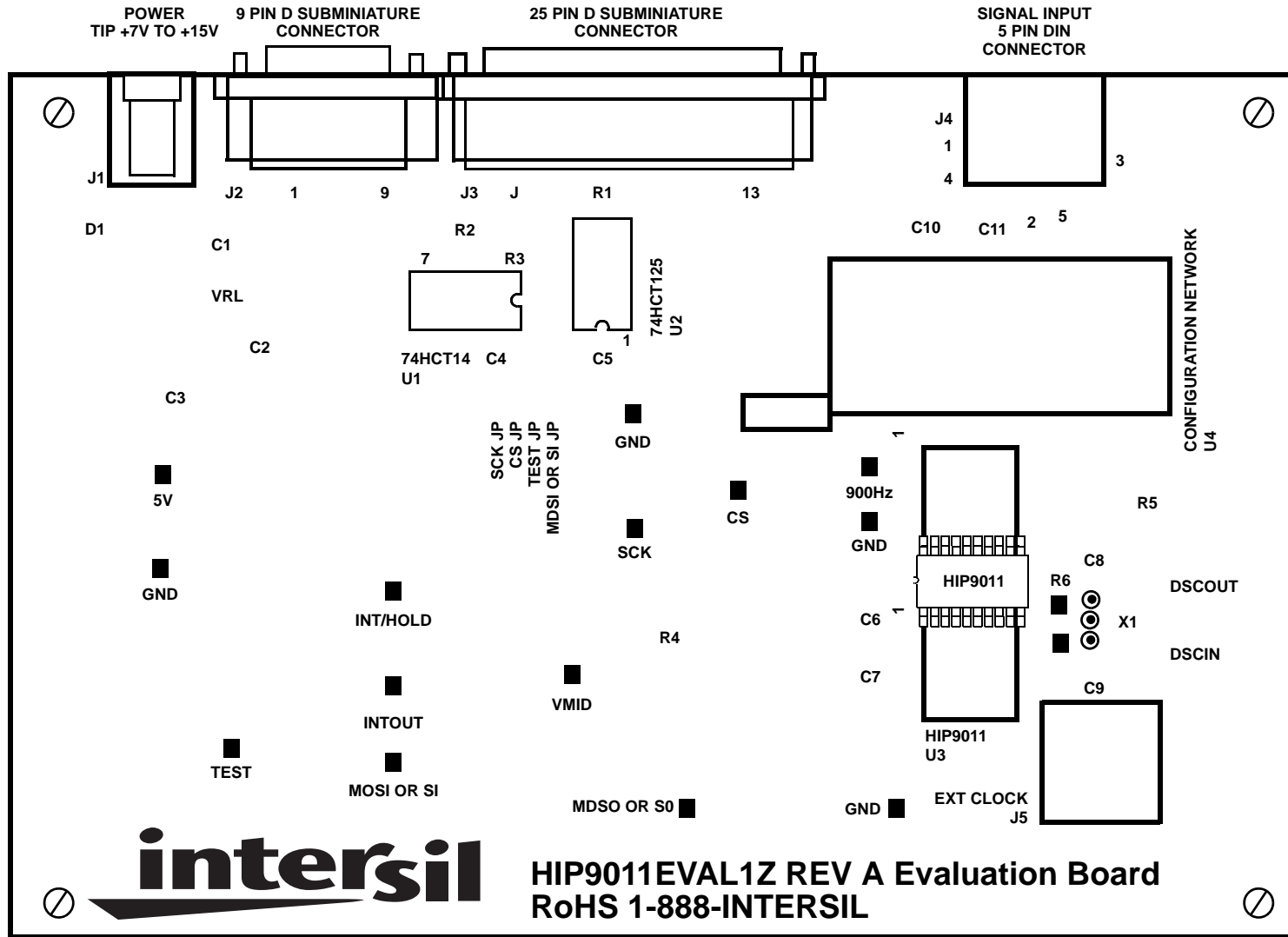

FIGURE 11. HIP9011 EVALUATION BOARD (HIP9011EVAL1Z)

Installing Knock Signal Processor Software in Microsoft® Windows 95® and Windows 98®

1. Download the HIP9011EVAL1Z evaluation board software (HIP9011.exe) from the Intersil website to your computer desktop.
2. To run the software, double-click the HIP9011.exe program icon. Multiple programs can be displayed with different conditions. Double-clicking on the desired program will activate those conditions.

WARNING: Set system font to small. Large fonts will cause the program to be unreadable.

If the INT/ $\overline{\text{HOLD}}$ signal from either the pulse generator or the engine is not applied to the Parallel Port of the PC, the PC

will lock up when you click on the blocks within the block diagram.

When the system is operating, the computer < > keys will step through each item in the selected window on the block diagram. The function is selected or activated by clicking the left mouse button when the spark plug pointer is on that desired function box. The End and Home keys will take the function to either extreme. Clicking with the pointer on the dots of the channel selection switch will activate that channel. Channel 0 is set to a gain of one and Channel 1 is set to a gain of two, so you can see the INTOUT signal increase when switching from Channel 0 to Channel 1.

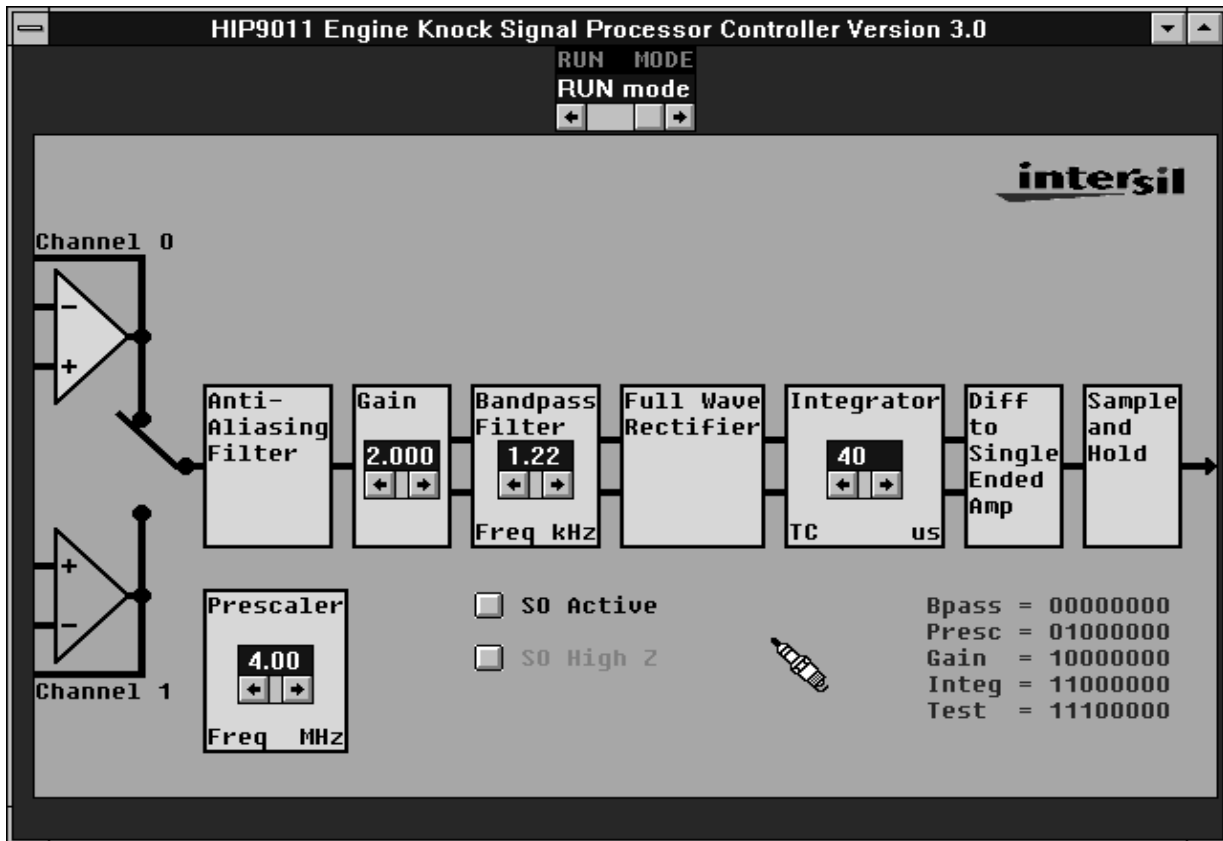
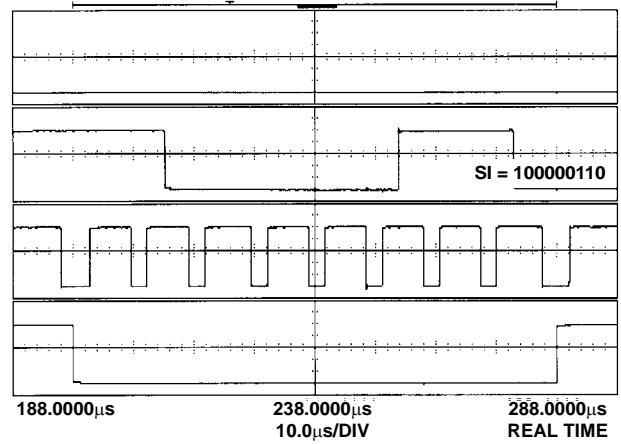
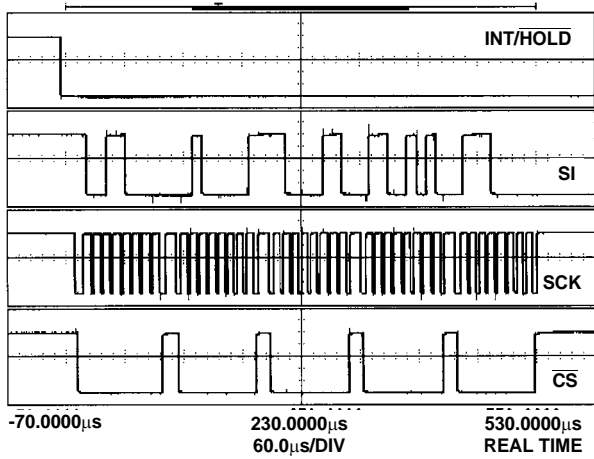

FIGURE 12. HIP9011 DISPLAY ON PC - DISPLAY IS IN COLOR

Intersil Corporation reserves the right to make changes in circuit design, software and/or specifications at any time without notice. Accordingly, the reader is cautioned to verify that the Application Note or Technical Brief is current before proceeding.



NOTE: Above display shows all five words written to the HIP9011 by the PC. The following displays show in more detail each of four words for Gain, Filter Frequency, Integrator TC and Prescaler.

FIGURE 13. DATA WRITING SEQUENCE TO THE HIP9011 VIA THE SPI BUS

FIGURE 14. WRITING THE GAIN BYTE TO THE HIP9011

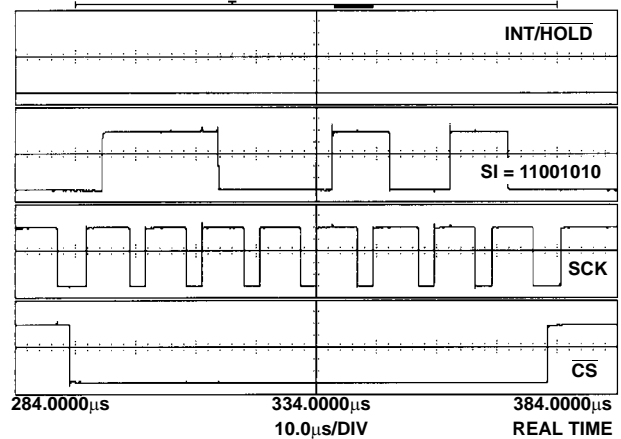
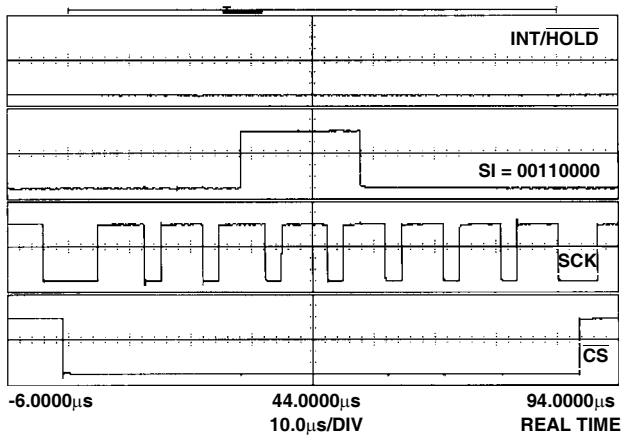

FIGURE 15. WRITING THE BANDPASS BYTE TO THE HIP9011

FIGURE 16. WRITING THE INTEGRATOR BYTE TO THE HIP9011

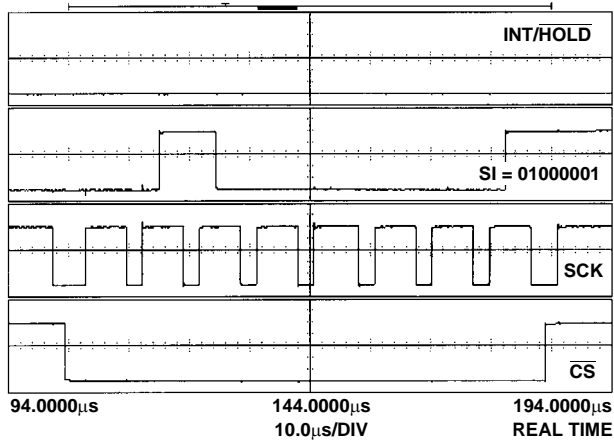

FIGURE 17. WRITING THE PRESCALER BYTE TO THE HIP9011