

## Photomicrosensor (Reflective) EE-SY1200

**⚠ Be sure to read *Precautions* on page 24.**

### ■ Dimensions

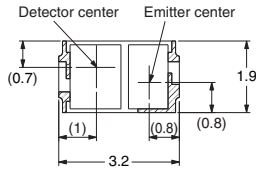

**Note:**  
Unless otherwise specified tolerances are  $\pm 0.15$ .  
No burrs dimensions are included in outline dimensions.  
The burrs dimensions are 0.15 MAX.  
Diagonal line indicate the region is part Au plating area.

#### Recommended Soldering Pattern

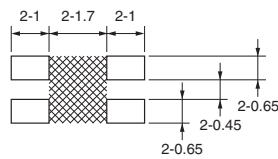

**Note:1.** The shaded portion in the above figure may cause shorting. Do not wire in this portion.  
**2.** The dimensional tolerance for the recommended soldering pattern is  $\pm 0.1$  mm.

#### Internal Circuit

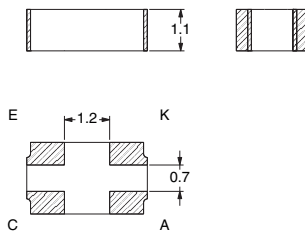
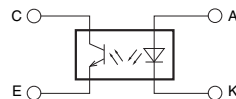

Terminal No.	Name
A	Anode
K	Cathode
C	Collector
E	Emitter

### ■ Features

- Ultra-compact model.
- PCB surface mounting type.
- High S/N ratio (High light current / Low leakage current)
- Recommended sensing distance = 1.0 to 4.0 mm

### ■ Absolute Maximum Ratings (Ta=25°C)

Item	Symbol	Rated value	Unit
Emitter	Forward current	$I_F$	$50^{*1}$ mA
	Pulse forward current	$I_{FP}$	$500^{*2}$ mA
	Reverse voltage	$V_R$	4 V
Detector	Collector-Emitter voltage	$V_{CEO}$	30 V
	Emitter-Collector voltage	$V_{ECO}$	5 V
	Collector current	$I_C$	20 mA
	Collector dissipation	$P_C$	$50^{*1}$ mW
Operating temperature	$T_{opr}$	-25 to +85	°C
Storage temperature	$T_{stg}$	-40 to +100	°C
Reflow soldering temperature	$T_{sol}$	$240^{*3}$	°C

\*1 Refer to the temperature rating chart if the ambient temperature exceeds 25°C.

\*2 The pulse width is 10  $\mu$ s maximum with a frequency of 100 Hz.

\*3 Complete soldering within 10 seconds for reflow soldering.

### ■ Electrical and Optical Characteristics (Ta=25°C)

Item	Symbol	Value			Unit	Condition	
		MIN.	TYP.	MAX.			
Emitter	Forward voltage	$V_F$	---	1.2	1.4	V	$I_F = 20$ mA
	Reverse current	$I_R$	---	---	10	$\mu$ A	$V_R = 4$ V
	Peak emission wavelength	$\lambda_P$	---	940	---	nm	---
Detector	Light current 1	$I_{L1}$	200	---	1000	$\mu$ A	$I_F = 10$ mA, $V_{CE} = 2$ V, Aluminum-deposited surface, $d = 4$ mm <sup>*1</sup>
	Light current 2	$I_{L2}$	150	---	---	$\mu$ A	$I_F = 4$ mA, $V_{CE} = 2$ V, Aluminum-deposited surface, $d = 1$ mm <sup>*1</sup>
	Dark current	$I_D$	---	2	200	nA	$V_{CE} = 10$ V, 0 lx
	Leakage current 1	$I_{LEAK1}$	---	---	500	nA	$I_F = 10$ mA, $V_{CE} = 2$ V, with no reflection <sup>*2</sup>
	Leakage current 2	$I_{LEAK2}$	---	---	200	nA	$I_F = 4$ mA, $V_{CE} = 2$ V, with no reflection <sup>*2</sup>
	Collector-Emitter saturated voltage	$V_{CE(sat)}$	---	---	---	V	---
	Peak spectral sensitivity wavelength	$\lambda_P$	---	850	---	nm	---
Rising time	$t_r$	---	30	---	$\mu$ s	$V_{CC} = 2$ V, $R_L = 1$ k $\Omega$ , $I_L = 100$ $\mu$ A, $d = 1$ mm <sup>*1</sup>	
Falling time	$t_f$	---	30	---	$\mu$ s	$V_{CC} = 2$ V, $R_L = 1$ k $\Omega$ , $I_L = 100$ $\mu$ A, $d = 1$ mm <sup>*1</sup>	

\*1. The letter "d" indicates the distance between the top surface of the sensor and the sensing object.

\*2. Depends on the installed condition of the Photomicrosensor, the detector may receive the sensor's LED light and/or the external light which is reflected from surroundings of the Photomicrosensor and/or the background object.

Please confirm the condition of the Photomicrosensor by actual intended application prior to the mass production use.

**Engineering Data**

**Forward Current vs. Collector Dissipation Temperature Rating**

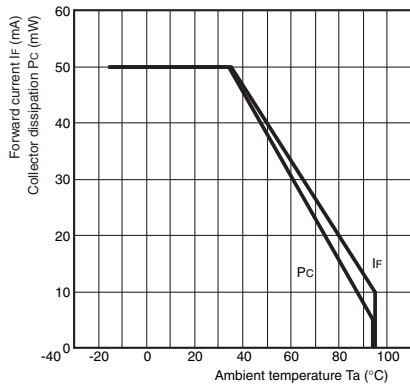

**Forward Current vs. Forward Voltage Characteristics (Typical)**

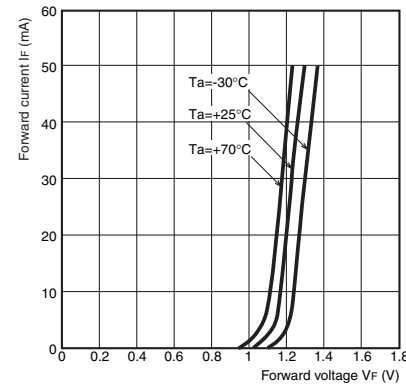

**Light Current vs. Forward Current Characteristics (Typical)**

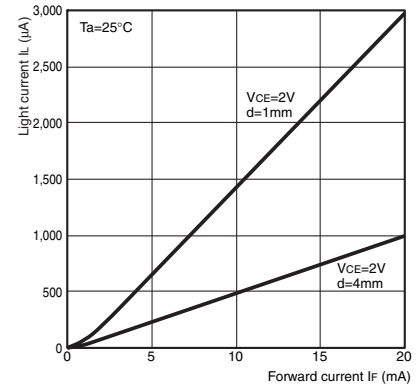

**Light Current vs. Collector-Emitter Voltage Characteristics (Typical)**

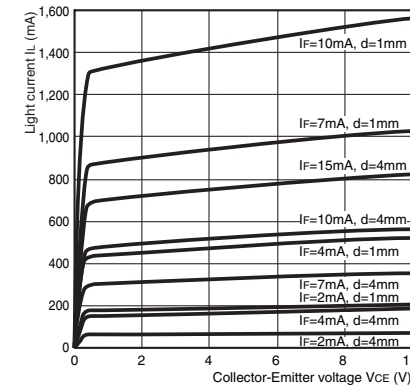

**Relative Light Current vs. Ambient Temperature Characteristics (Typical)**

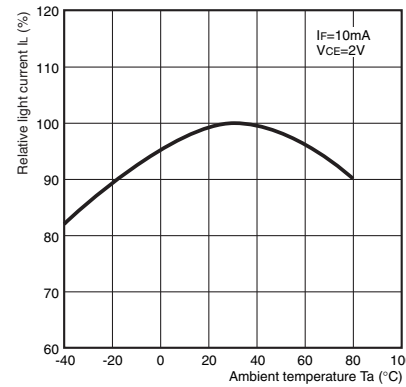

**Dark Current vs. Ambient Temperature Characteristics (Typical)**

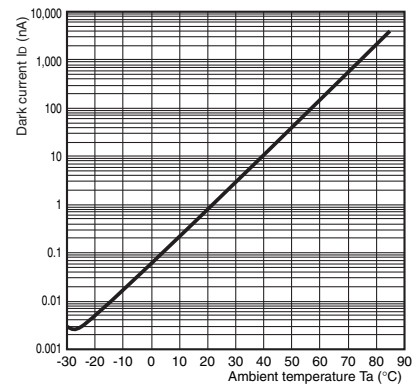

**Response Time vs. Load Resistance Characteristics (Typical)**

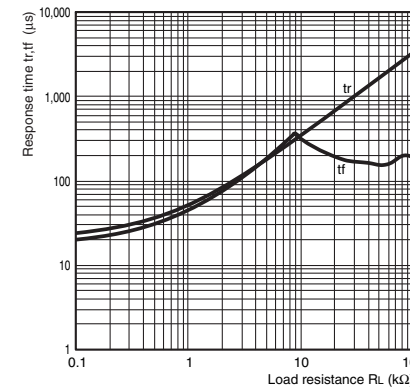

**Sensing Distance Characteristics (Typical)**

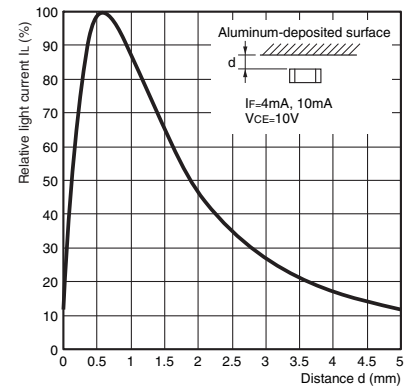

**Sensing Position Characteristics (Typical)**

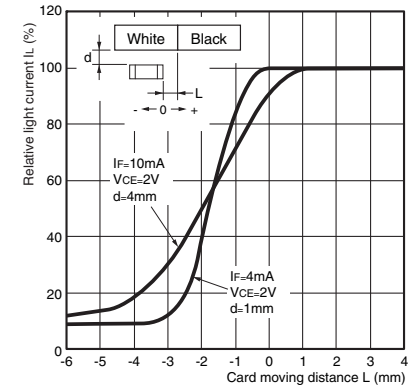

**Sensing Position Characteristics (Typical)**

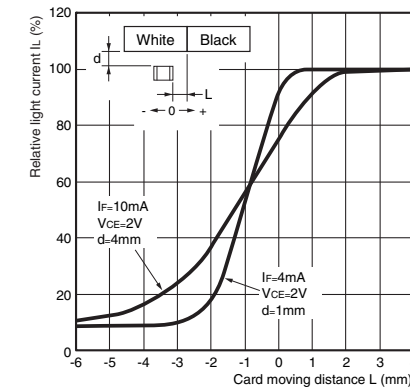

**Response Time Measurement Circuit**

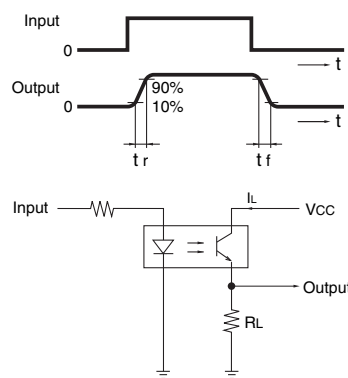

**Light Current Measurement Setup Diagram**

