

LMR12010 SIMPLE SWITCHER® 20Vin, 1A Step-Down Voltage Regulator in SOT-23

Check for Samples: [LMR12010](#)

FEATURES

- Input Voltage Range of 3V to 20V
- Output Voltage Range of 0.8V to 17V
- Output Current Up to 1A
- 1.6MHz (LMR12010X) and 3 MHz (LMR12010Y) Switching Frequencies
- Low Shutdown Iq, 30 nA Typical
- Internal Soft-start
- Internally Compensated
- Current-Mode PWM Operation
- Thermal Shutdown
- Thin SOT-23-6 Package (2.97 x 1.65 x 1mm)
- Fully Enabled for WEBENCH® Power Designer

APPLICATIONS

- Point-of-Load Conversions from 3.3V, 5V, and 12V Rails
- Space Constrained Applications
- Battery Powered Equipment
- Industrial Distributed Power Applications
- Power Meters
- Portable Hand-Held Instruments

PERFORMANCE BENEFITS

- Extremely Easy to Use
- Tiny Overall Solution Reduces System Cost

DESCRIPTION

The LMR12010 regulator is a monolithic, high frequency, PWM step-down DC/DC converter in a 6-pin Thin SOT-23 package. It provides all the active functions to provide local DC/DC conversion with fast transient response and accurate regulation in the smallest possible PCB area.

With a minimum of external components and online design support through WEBENCH, the LMR12010 is easy to use. The ability to drive 1A loads with an internal 300mΩ NMOS switch using state-of-the-art 0.5μm BiCMOS technology results in the best power density available. The world class control circuitry allows for on-times as low as 13ns, thus supporting exceptionally high frequency conversion over the entire 3V to 20V input operating range down to the minimum output voltage of 0.8V. Switching frequency is internally set to 1.6 MHz (LMR12010X) or 3 MHz (LMR12010Y), allowing the use of extremely small surface mount inductors and chip capacitors. Even though the operating frequencies are very high, efficiencies up to 90% are easy to achieve. External shutdown is included, featuring an ultra-low stand-by current of 30nA. The LMR12010 utilizes current-mode control and internal compensation to provide high-performance regulation over a wide range of operating conditions. Additional features include internal soft-start circuitry to reduce inrush current, pulse-by-pulse current limit, thermal shutdown, and output over-voltage protection.

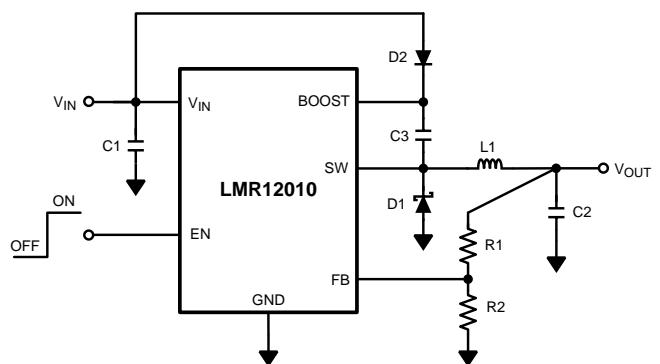

Please be aware that an important notice concerning availability, standard warranty, and use in critical applications of Texas Instruments semiconductor products and disclaimers thereto appears at the end of this data sheet.

SIMPLE SWITCHER, WEBENCH are registered trademarks of Texas Instruments.
All other trademarks are the property of their respective owners.

System Performance

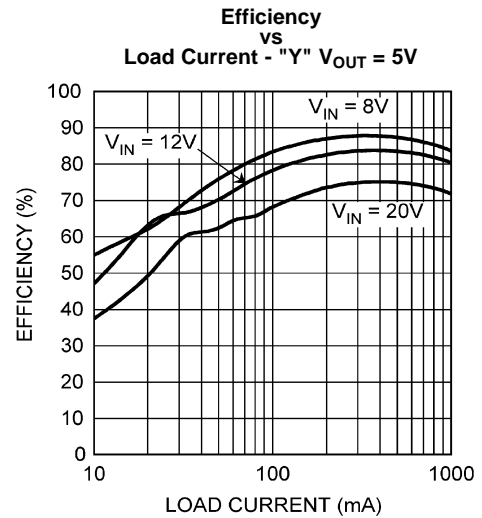
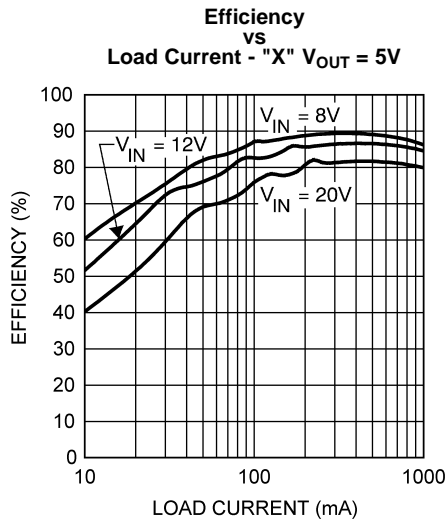

Connection Diagram

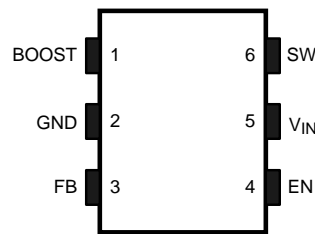

Figure 1. 6-Lead SOT Package Number DDC0006A

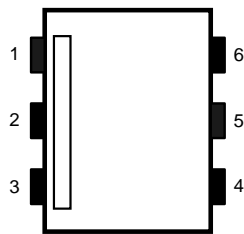

Figure 2. Pin 1 Identification

PIN DESCRIPTIONS

Pin	Name	Function
1	BOOST	Boost voltage that drives the internal NMOS control switch. A bootstrap capacitor is connected between the BOOST and SW pins.
2	GND	Signal and Power ground pin. Place the bottom resistor of the feedback network as close as possible to this pin for accurate regulation.
3	FB	Feedback pin. Connect FB to the external resistor divider to set output voltage.
4	EN	Enable control input. Logic high enables operation. Do not allow this pin to float or be greater than $V_{IN} + 0.3V$.
5	V_{IN}	Input supply voltage. Connect a bypass capacitor to this pin.
6	SW	Output switch. Connects to the inductor, catch diode, and bootstrap capacitor.



These devices have limited built-in ESD protection. The leads should be shorted together or the device placed in conductive foam during storage or handling to prevent electrostatic damage to the MOS gates.

ABSOLUTE MAXIMUM RATINGS⁽¹⁾⁽²⁾

V _{IN}	-0.5V to 24V
SW Voltage	-0.5V to 24V
Boost Voltage	-0.5V to 30V
Boost to SW Voltage	-0.5V to 6.0V
FB Voltage	-0.5V to 3.0V
EN Voltage	-0.5V to (V _{IN} + 0.3V)
Junction Temperature	150°C
ESD Susceptibility ⁽³⁾	2kV
Storage Temp. Range	-65°C to 150°C
For soldering specifications: see product folder at www.ti.com and literature number SNOA549	

- (1) Absolute Maximum Ratings indicate limits beyond which damage to the device may occur. Operating Ratings indicate conditions for which the device is intended to be functional, but specific performance is not ensured. For ensured specifications and the test conditions, see Electrical Characteristics.
- (2) If Military/Aerospace specified devices are required, please contact the Texas Instruments Sales Office/Distributors for availability and specifications.
- (3) Human body model, 1.5kΩ in series with 100pF.

OPERATING RATINGS⁽¹⁾

V _{IN}	3V to 20V
SW Voltage	-0.5V to 20V
Boost Voltage	-0.5V to 25V
Boost to SW Voltage	1.6V to 5.5V
Junction Temperature Range	-40°C to +125°C
Thermal Resistance θ _{JA} ⁽²⁾	118°C/W

- (1) Absolute Maximum Ratings indicate limits beyond which damage to the device may occur. Operating Ratings indicate conditions for which the device is intended to be functional, but specific performance is not ensured. For ensured specifications and the test conditions, see Electrical Characteristics.
- (2) Thermal shutdown will occur if the junction temperature exceeds 165°C. The maximum power dissipation is a function of T_{J(MAX)}, θ_{JA} and T_A. The maximum allowable power dissipation at any ambient temperature is P_D = (T_{J(MAX)} - T_A)/θ_{JA}. All numbers apply for packages soldered directly onto a 3" x 3" PC board with 2oz. copper on 4 layers in still air. For a 2 layer board using 1 oz. copper in still air, θ_{JA} = 204°C/W.

ELECTRICAL CHARACTERISTICS

Specifications with standard typeface are for T_J = 25°C, and those in **boldface type** apply over the full **Operating Temperature Range** (T_J = -40°C to 125°C). V_{IN} = 5V, V_{BOOST} - V_{SW} = 5V unless otherwise specified. Datasheet min/max specification limits are specified by design, test, or statistical analysis.

Symbol	Parameter	Conditions	Min ⁽¹⁾	Typ ⁽²⁾	Max ⁽¹⁾	Units
V _{FB}	Feedback Voltage		0.784	0.800	0.816	V
ΔV _{FB} /ΔV _{IN}	Feedback Voltage Line Regulation	V _{IN} = 3V to 20V		0.01		% / V
I _{FB}	Feedback Input Bias Current	Sink/Source		10	250	nA
UVLO	Undervoltage Lockout	V _{IN} Rising		2.74	2.90	V
	Undervoltage Lockout	V _{IN} Falling	2.0	2.3		
	UVLO Hysteresis		0.30	0.44	0.62	
F _{SW}	Switching Frequency	LMR12010X	1.2	1.6	1.9	MHz
		LMR12010Y	2.2	3.0	3.6	
D _{MAX}	Maximum Duty Cycle	LMR12010X	85	92		%
		LMR12010Y	78	85		

- (1) Specified to TI's Average Outgoing Quality Level (AOQL).
- (2) Typical values represent the most likely parametric norm.

ELECTRICAL CHARACTERISTICS (continued)

Specifications with standard typeface are for $T_J = 25^\circ\text{C}$, and those in **boldface type** apply over the full **Operating Temperature Range** ($T_J = -40^\circ\text{C}$ to 125°C). $V_{IN} = 5\text{V}$, $V_{BOOST} - V_{SW} = 5\text{V}$ unless otherwise specified. Datasheet min/max specification limits are specified by design, test, or statistical analysis.

Symbol	Parameter	Conditions	Min (1)	Typ (2)	Max (1)	Units
D_{MIN}	Minimum Duty Cycle	LMR12010X		2		%
		LMR12010Y		8		
$R_{DS(ON)}$	Switch ON Resistance	$V_{BOOST} - V_{SW} = 3\text{V}$		300	600	m Ω
I_{CL}	Switch Current Limit	$V_{BOOST} - V_{SW} = 3\text{V}$	1.2	1.7	2.5	A
I_Q	Quiescent Current	Switching		1.5	2.5	mA
	Quiescent Current (shutdown)	$V_{EN} = 0\text{V}$		30		nA
I_{BOOST}	Boost Pin Current	LMR12010X (50% Duty Cycle)		2.5	3.5	mA
		LMR12010Y (50% Duty Cycle)		4.25	6.0	
V_{EN_TH}	Shutdown Threshold Voltage	V_{EN} Falling			0.4	V
	Enable Threshold Voltage	V_{EN} Rising	1.8			
I_{EN}	Enable Pin Current	Sink/Source		10		nA
I_{SW}	Switch Leakage			40		nA

TYPICAL PERFORMANCE CHARACTERISTICS

All curves taken at $V_{IN} = 5V$, $V_{BOOST} - V_{SW} = 5V$, $L1 = 4.7 \mu H$ ("X"), $L1 = 2.2 \mu H$ ("Y") and $T_A = 25^\circ C$, unless specified otherwise.

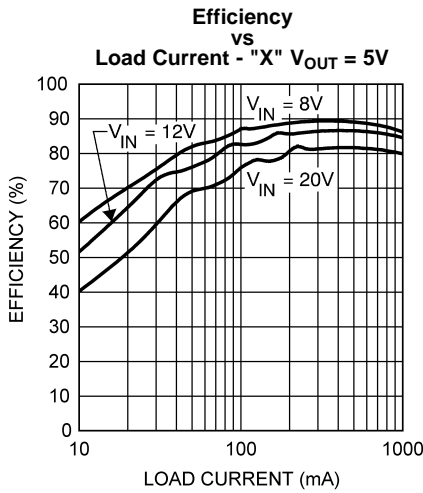

Figure 3.

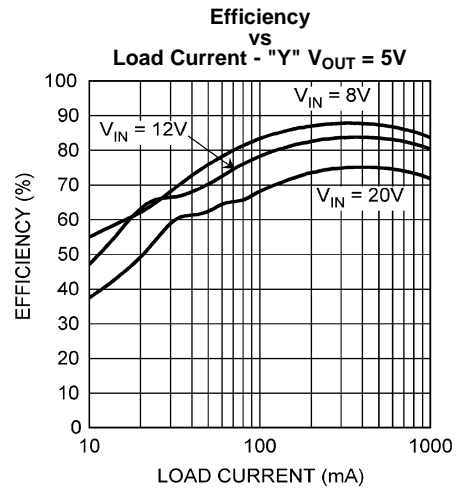

Figure 4.

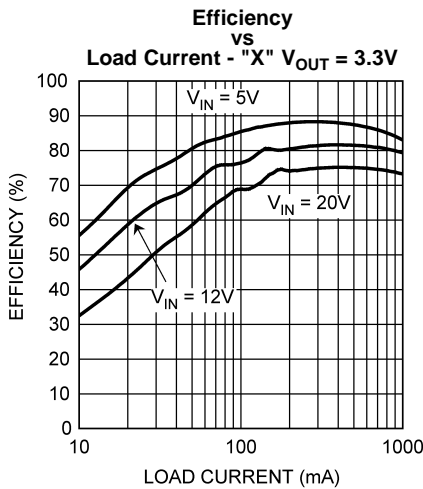

Figure 5.

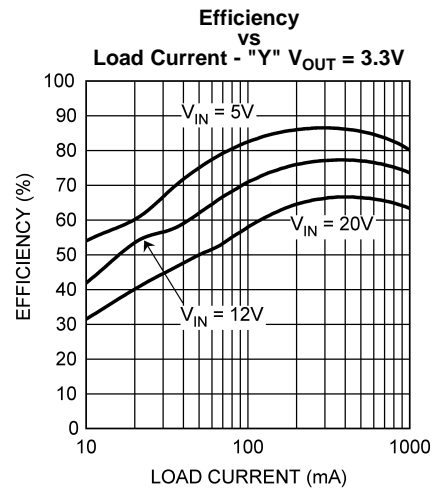

Figure 6.

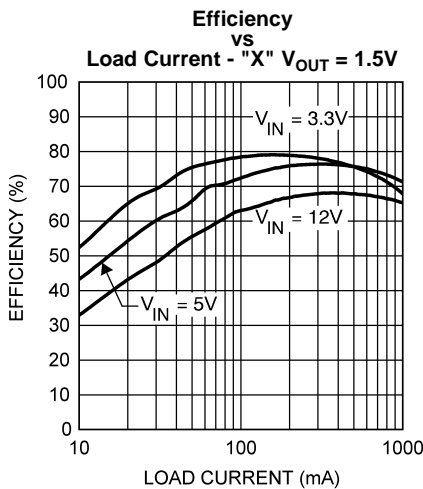

Figure 7.

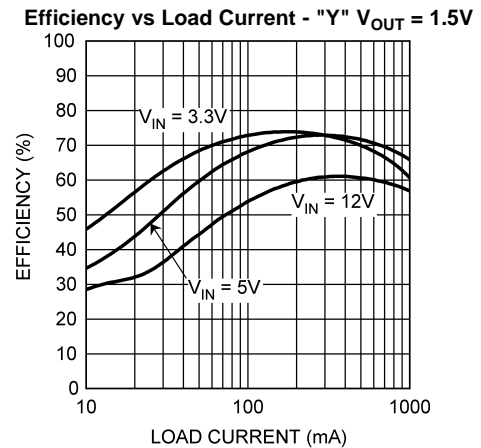

Figure 8.

TYPICAL PERFORMANCE CHARACTERISTICS (continued)

All curves taken at $V_{IN} = 5V$, $V_{BOOST} - V_{SW} = 5V$, $L1 = 4.7 \mu H$ ("X"), $L1 = 2.2 \mu H$ ("Y") and $T_A = 25^\circ C$, unless specified otherwise.

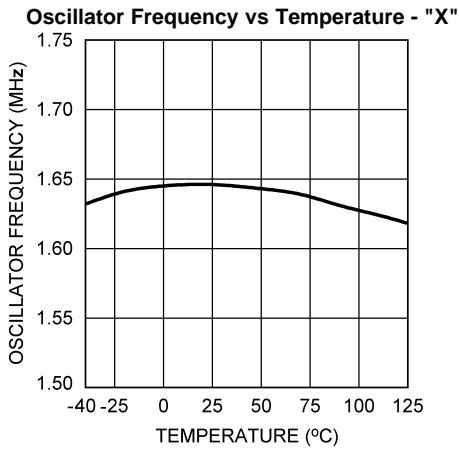

Figure 9.

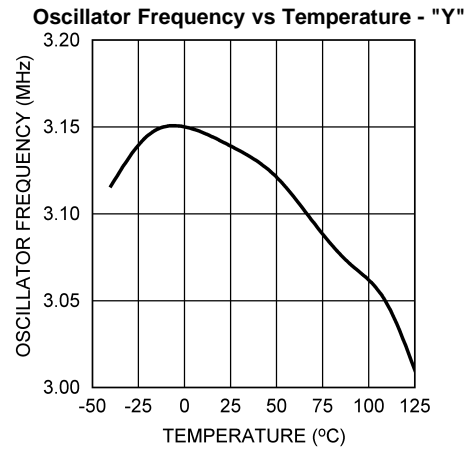

Figure 10.

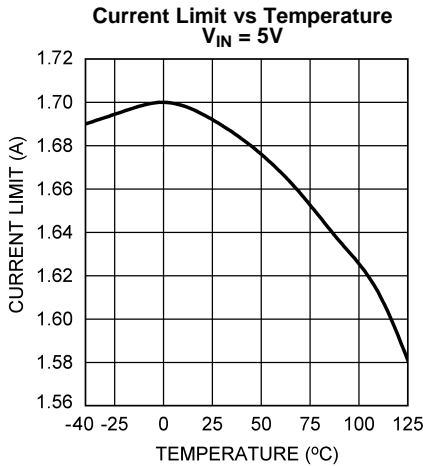

Figure 11.

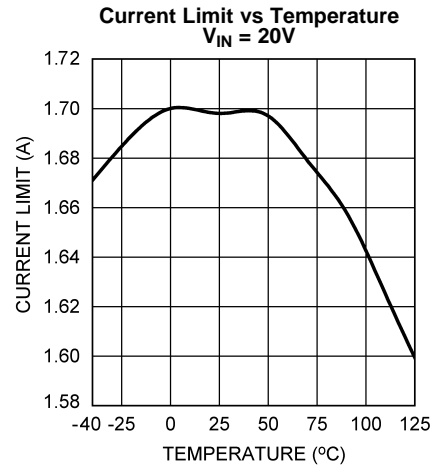

Figure 12.

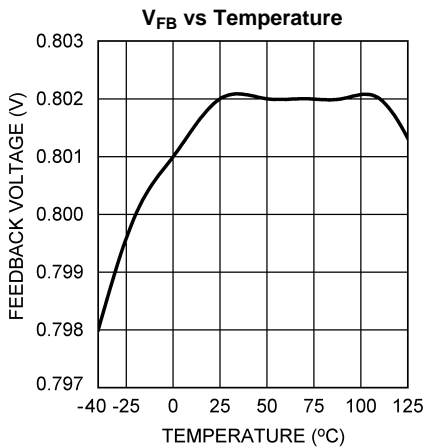

Figure 13.

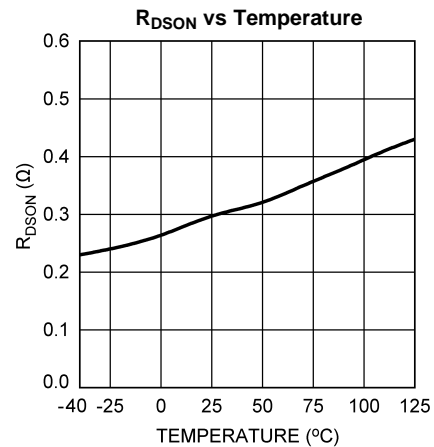

Figure 14.

TYPICAL PERFORMANCE CHARACTERISTICS (continued)

All curves taken at $V_{IN} = 5V$, $V_{BOOST} - V_{SW} = 5V$, $L1 = 4.7 \mu H$ ("X"), $L1 = 2.2 \mu H$ ("Y") and $T_A = 25^\circ C$, unless specified otherwise.

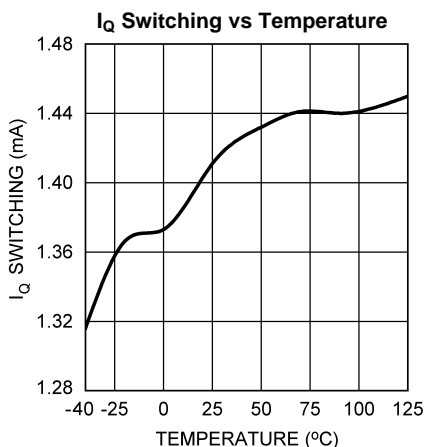

Figure 15.

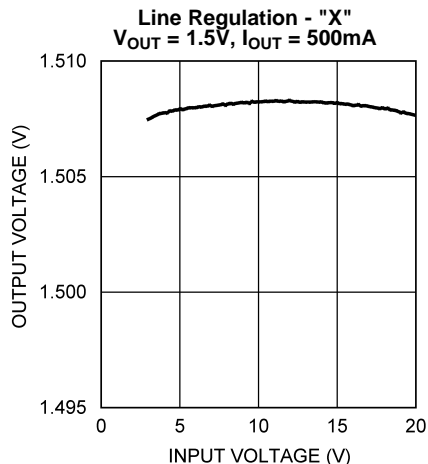

Figure 16.

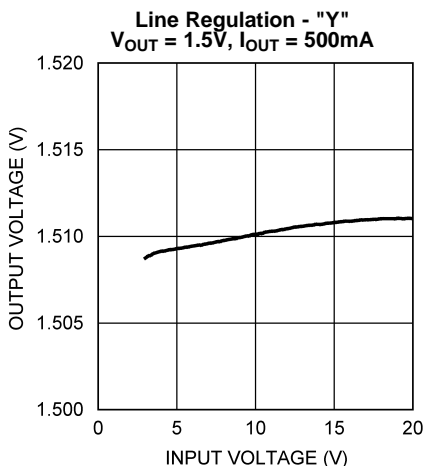

Figure 17.

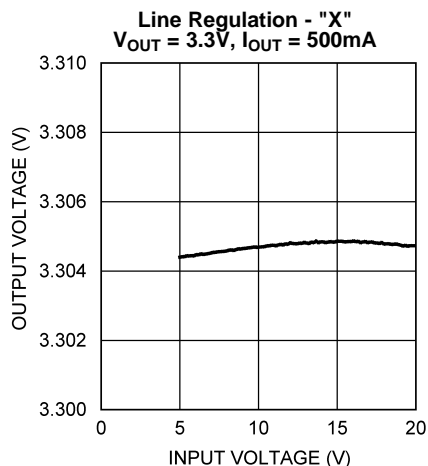

Figure 18.

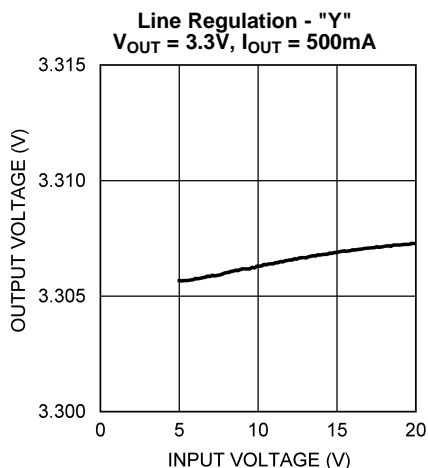

Figure 19.

BLOCK DIAGRAM

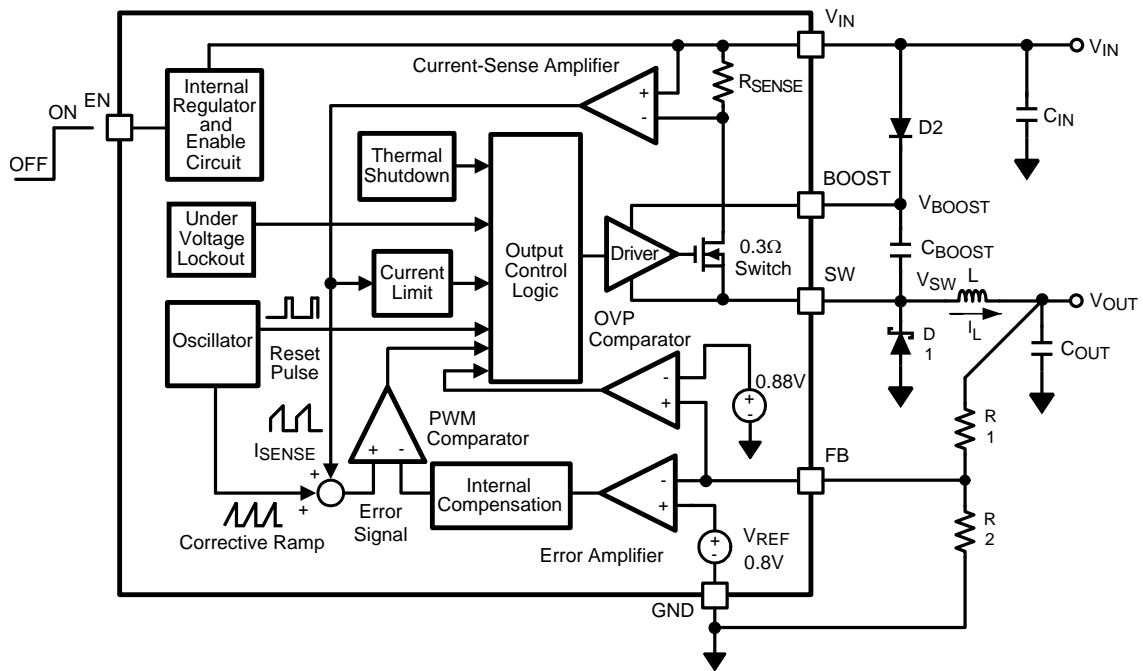

Figure 20.

APPLICATION INFORMATION

Theory of Operation

The LMR12010 is a constant frequency PWM buck regulator IC that delivers a 1A load current. The regulator has a preset switching frequency of either 3 MHz (LMR12010Y) or 1.6MHz (LMR12010X). These high frequencies allow the LMR12010 to operate with small surface mount capacitors and inductors, resulting in DC/DC converters that require a minimum amount of board space. The LMR12010 is internally compensated, so it is simple to use, and requires few external components. The LMR12010 uses current-mode control to regulate the output voltage.

The following operating description of the LMR12010 will refer to the Simplified Block Diagram (Figure 20) and to the waveforms in Figure 21. The LMR12010 supplies a regulated output voltage by switching the internal NMOS control switch at constant frequency and variable duty cycle. A switching cycle begins at the falling edge of the reset pulse generated by the internal oscillator. When this pulse goes low, the output control logic turns on the internal NMOS control switch. During this on-time, the SW pin voltage (V_{SW}) swings up to approximately V_{IN} , and the inductor current (I_L) increases with a linear slope. I_L is measured by the current-sense amplifier, which generates an output proportional to the switch current. The sense signal is summed with the regulator's corrective ramp and compared to the error amplifier's output, which is proportional to the difference between the feedback voltage and V_{REF} . When the PWM comparator output goes high, the output switch turns off until the next switching cycle begins. During the switch off-time, inductor current discharges through Schottky diode D1, which forces the SW pin to swing below ground by the forward voltage (V_D) of the catch diode. The regulator loop adjusts the duty cycle (D) to maintain a constant output voltage.

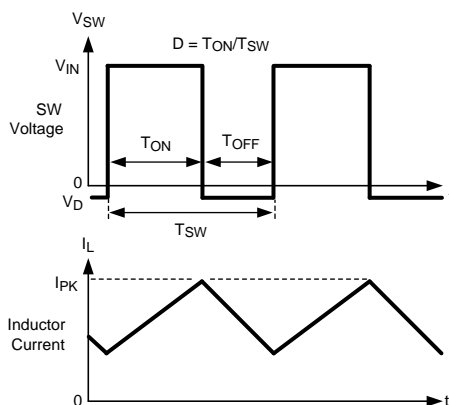

Figure 21. LMR12010 Waveforms of SW Pin Voltage and Inductor Current

BOOST Function

Capacitor C_{BOOST} and diode D2 in Figure 22 are used to generate a voltage V_{BOOST} . $V_{BOOST} - V_{SW}$ is the gate drive voltage to the internal NMOS control switch. To properly drive the internal NMOS switch during its on-time, V_{BOOST} needs to be at least 1.6V greater than V_{SW} . Although the LMR12010 will operate with this minimum voltage, it may not have sufficient gate drive to supply large values of output current. Therefore, it is recommended that V_{BOOST} be greater than 2.5V above V_{SW} for best efficiency. $V_{BOOST} - V_{SW}$ should not exceed the maximum operating limit of 5.5V.

$5.5V > V_{BOOST} - V_{SW} > 2.5V$ for best performance.

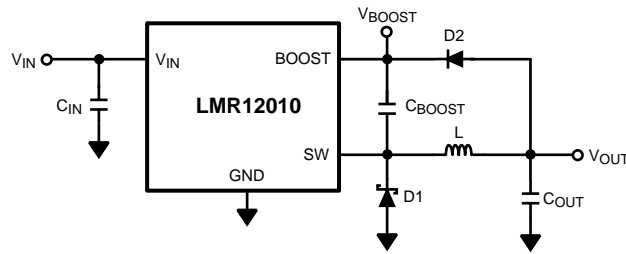

Figure 22. V_{OUT} Charges C_{BOOST}

When the LMR12010 starts up, internal circuitry from the BOOST pin supplies a maximum of 20mA to C_{BOOST} . This current charges C_{BOOST} to a voltage sufficient to turn the switch on. The BOOST pin will continue to source current to C_{BOOST} until the voltage at the feedback pin is greater than 0.76V.

There are various methods to derive V_{BOOST} :

1. From the input voltage (V_{IN})
2. From the output voltage (V_{OUT})
3. From an external distributed voltage rail (V_{EXT})
4. From a shunt or series zener diode

In the Simplified Block Diagram of Figure 20, capacitor C_{BOOST} and diode D2 supply the gate-drive current for the NMOS switch. Capacitor C_{BOOST} is charged via diode D2 by V_{IN} . During a normal switching cycle, when the internal NMOS control switch is off (T_{OFF}) (refer to Figure 21), V_{BOOST} equals V_{IN} minus the forward voltage of D2 (V_{FD2}), during which the current in the inductor (L) forward biases the Schottky diode D1 (V_{FD1}). Therefore the voltage stored across C_{BOOST} is

$$V_{BOOST} - V_{SW} = V_{IN} - V_{FD2} + V_{FD1} \quad (1)$$

When the NMOS switch turns on (T_{ON}), the switch pin rises to

$$V_{SW} = V_{IN} - (R_{DS(on)} \times I_L), \quad (2)$$

forcing V_{BOOST} to rise thus reverse biasing D2. The voltage at V_{BOOST} is then

$$V_{BOOST} = 2V_{IN} - (R_{DS(on)} \times I_L) - V_{FD2} + V_{FD1} \quad (3)$$

which is approximately

$$2V_{IN} - 0.4V \quad (4)$$

for many applications. Thus the gate-drive voltage of the NMOS switch is approximately

$$V_{IN} - 0.2V \quad (5)$$

An alternate method for charging C_{BOOST} is to connect D2 to the output as shown in Figure 22. The output voltage should be between 2.5V and 5.5V, so that proper gate voltage will be applied to the internal switch. In this circuit, C_{BOOST} provides a gate drive voltage that is slightly less than V_{OUT} .

In applications where both V_{IN} and V_{OUT} are greater than 5.5V, or less than 3V, C_{BOOST} cannot be charged directly from these voltages. If V_{IN} and V_{OUT} are greater than 5.5V, C_{BOOST} can be charged from V_{IN} or V_{OUT} minus a zener voltage by placing a zener diode D3 in series with D2, as shown in Figure 23. When using a series zener diode from the input, ensure that the regulation of the input supply doesn't create a voltage that falls outside the recommended V_{BOOST} voltage.

$$(V_{INMAX} - V_{D3}) < 5.5V$$

$$(V_{INMIN} - V_{D3}) > 1.6V$$

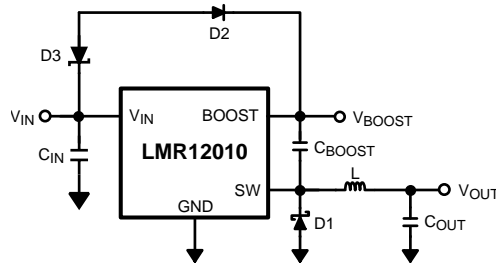

Figure 23. Zener Reduces Boost Voltage from V_{IN}

An alternative method is to place the zener diode D3 in a shunt configuration as shown in Figure 24. A small 350mW to 500mW 5.1V zener in a SOT-23 or SOD package can be used for this purpose. A small ceramic capacitor such as a 6.3V, 0.1 μ F capacitor (C4) should be placed in parallel with the zener diode. When the internal NMOS switch turns on, a pulse of current is drawn to charge the internal NMOS gate capacitance. The 0.1 μ F parallel shunt capacitor ensures that the V_{BOOST} voltage is maintained during this time.

Resistor R3 should be chosen to provide enough RMS current to the zener diode (D3) and to the BOOST pin. A recommended choice for the zener current (I_{ZENER}) is 1 mA. The current I_{BOOST} into the BOOST pin supplies the gate current of the NMOS control switch and varies typically according to the following formula for the X version:

$$I_{BOOST} = 0.56 \times (D + 0.54) \times (V_{ZENER} - V_{D2}) \text{ mA} \quad (6)$$

I_{BOOST} can be calculated for the Y version using the following:

$$I_{BOOST} = (D + 0.5) \times (V_{ZENER} - V_{D2}) \text{ mA}$$

where

- D is the duty cycle
- V_{ZENER} and V_{D2} are in volts
- I_{BOOST} is in milliamps

(7)

V_{ZENER} is the voltage applied to the anode of the boost diode (D2), and V_{D2} is the average forward voltage across D2. Note that this formula for I_{BOOST} gives typical current. For the worst case I_{BOOST} , increase the current by 40%. In that case, the worst case boost current will be

$$I_{BOOST-MAX} = 1.4 \times I_{BOOST} \quad (8)$$

R3 will then be given by

$$R3 = (V_{IN} - V_{ZENER}) / (1.4 \times I_{BOOST} + I_{ZENER}) \quad (9)$$

For example, using the X-version let $V_{IN} = 10V$, $V_{ZENER} = 5V$, $V_{D2} = 0.7V$, $I_{ZENER} = 1mA$, and duty cycle $D = 50\%$. Then

$$I_{BOOST} = 0.56 \times (0.5 + 0.54) \times (5 - 0.7) \text{ mA} = 2.5\text{mA} \quad (10)$$

$$R3 = (10V - 5V) / (1.4 \times 2.5\text{mA} + 1\text{mA}) = 1.11\text{k}\Omega \quad (11)$$

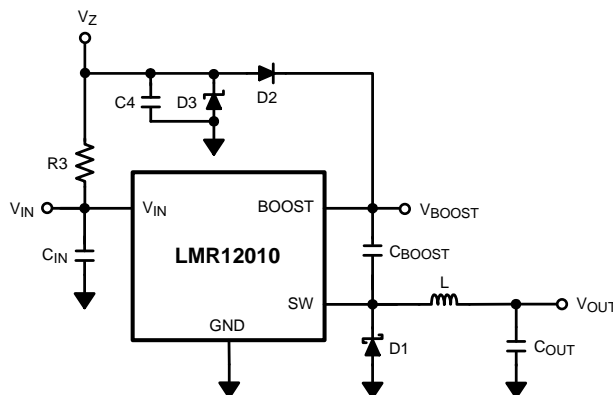
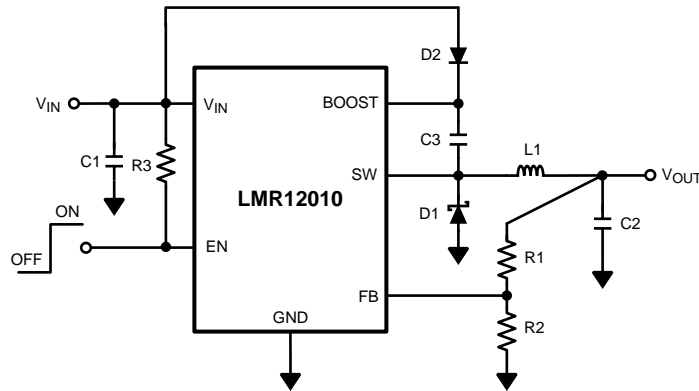
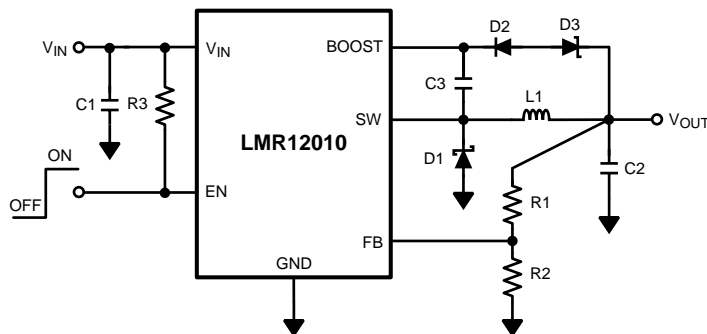

Figure 24. Boost Voltage Supplied from the Shunt Zener on V_{IN}

Figure 25. V_{BOOST} Derived from V_{IN} Figure 26. V_{BOOST} Derived from Series Zener Diode (V_{OUT})

Enable Pin / Shutdown Mode

The LMR12010 has a shutdown mode that is controlled by the enable pin (EN). When a logic low voltage is applied to EN, the part is in shutdown mode and its quiescent current drops to typically 30nA. Switch leakage adds another 40nA from the input supply. The voltage at this pin should never exceed $V_{\text{IN}} + 0.3\text{V}$.

SOFT-START

This function forces V_{OUT} to increase at a controlled rate during start up. During soft-start, the error amplifier's reference voltage ramps from 0V to its nominal value of 0.8V in approximately 200 μs . This forces the regulator output to ramp up in a more linear and controlled fashion, which helps reduce inrush current. Under some circumstances at start-up, an output voltage overshoot may still be observed. This may be due to a large output load applied during start up. Large amounts of output external capacitance can also increase output voltage overshoot. A simple solution is to add a feed forward capacitor with a value between 470pf and 1000pf across the top feedback resistor (R1).

Output Overvoltage Protections

The overvoltage comparator compares the FB pin voltage to a voltage that is 10% higher than the internal reference V_{ref} . Once the FB pin voltage goes 10% above the internal reference, the internal NMOS control switch is turned off, which allows the output voltage to decrease toward regulation.

Undervoltage Lockout

Undervoltage lockout (UVLO) prevents the LMR12010 from operating until the input voltage exceeds 2.74V(typ).

The UVLO threshold has approximately 440mV of hysteresis, so the part will operate until V_{IN} drops below 2.3V(typ). Hysteresis prevents the part from turning off during power up if V_{IN} is non-monotonic.

Current Limit

The LMR12010 uses cycle-by-cycle current limiting to protect the output switch. During each switching cycle, a current limit comparator detects if the output switch current exceeds 1.7A (typ), and turns off the switch until the next switching cycle begins.

Thermal Shutdown

Thermal shutdown limits total power dissipation by turning off the output switch when the IC junction temperature exceeds 165°C. After thermal shutdown occurs, the output switch doesn't turn on until the junction temperature drops to approximately 150°C.

Design Guide

Inductor Selection

The Duty Cycle (D) can be approximated quickly using the ratio of output voltage (V_O) to input voltage (V_{IN}):

$$D = \frac{V_O}{V_{IN}} \quad (12)$$

The catch diode (D1) forward voltage drop and the voltage drop across the internal NMOS must be included to calculate a more accurate duty cycle. Calculate D by using the following formula:

$$D = \frac{V_O + V_D}{V_{IN} + V_D - V_{SW}} \quad (13)$$

V_{SW} can be approximated by:

$$V_{SW} = I_O \times R_{DS(ON)} \quad (14)$$

The diode forward drop (V_D) can range from 0.3V to 0.7V depending on the quality of the diode. The lower V_D is, the higher the operating efficiency of the converter.

The inductor value determines the output ripple current. Lower inductor values decrease the size of the inductor, but increase the output ripple current. An increase in the inductor value will decrease the output ripple current. The ratio of ripple current (ΔI_L) to output current (I_O) is optimized when it is set between 0.3 and 0.4 at 1A. The ratio r is defined as:

$$r = \frac{\Delta I_L}{I_O} \quad (15)$$

One must also ensure that the minimum current limit (1.2A) is not exceeded, so the peak current in the inductor must be calculated. The peak current (I_{LPK}) in the inductor is calculated by:

$$I_{LPK} = I_O + \Delta I_L / 2 \quad (16)$$

If $r = 0.5$ at an output of 1A, the peak current in the inductor will be 1.25A. The minimum specified current limit over all operating conditions is 1.2A. One can either reduce r to 0.4 resulting in a 1.2A peak current, or make the engineering judgement that 50mA over will be safe enough with a 1.7A typical current limit and 6 sigma limits. When the designed maximum output current is reduced, the ratio r can be increased. At a current of 0.1A, r can be made as high as 0.9. The ripple ratio can be increased at lighter loads because the net ripple is actually quite low, and if r remains constant the inductor value can be made quite large. An equation empirically developed for the maximum ripple ratio at any current below 2A is:

$$r = 0.387 \times I_{OUT}^{-0.3667} \quad (17)$$

Note that this is just a guideline.

The LMR12010 operates at frequencies allowing the use of ceramic output capacitors without compromising transient response. Ceramic capacitors allow higher inductor ripple without significantly increasing output ripple. See the [Output Capacitor](#) section for more details on calculating output voltage ripple.

Now that the ripple current or ripple ratio is determined, the inductance is calculated by:

$$L = \frac{V_o + V_D}{I_o \times r \times f_s} \times (1-D)$$

where

- f_s is the switching frequency
- I_o is the output current

(18)

When selecting an inductor, make sure that it is capable of supporting the peak output current without saturating. Inductor saturation will result in a sudden reduction in inductance and prevent the regulator from operating correctly. Because of the speed of the internal current limit, the peak current of the inductor need only be specified for the required maximum output current. For example, if the designed maximum output current is 0.5A and the peak current is 0.7A, then the inductor should be specified with a saturation current limit of >0.7A. There is no need to specify the saturation or peak current of the inductor at the 1.7A typical switch current limit. The difference in inductor size is a factor of 5. Because of the operating frequency of the LMR12010, ferrite based inductors are preferred to minimize core losses. This presents little restriction since the variety of ferrite based inductors is huge. Lastly, inductors with lower series resistance (DCR) will provide better operating efficiency. For recommended inductors see Example Circuits.

Input Capacitor

An input capacitor is necessary to ensure that V_{IN} does not drop excessively during switching transients. The primary specifications of the input capacitor are capacitance, voltage, RMS current rating, and ESL (Equivalent Series Inductance). The recommended input capacitance is 10 μ F, although 4.7 μ F works well for input voltages below 6V. The input voltage rating is specifically stated by the capacitor manufacturer. Make sure to check any recommended deratings and also verify if there is any significant change in capacitance at the operating input voltage and the operating temperature. The input capacitor maximum RMS input current rating (I_{RMS-IN}) must be greater than:

$$I_{RMS-IN} = I_o \times \sqrt{D \times \left(1-D + \frac{r^2}{12}\right)}$$

(19)

It can be shown from the above equation that maximum RMS capacitor current occurs when $D = 0.5$. Always calculate the RMS at the point where the duty cycle, D , is closest to 0.5. The ESL of an input capacitor is usually determined by the effective cross sectional area of the current path. A large leaded capacitor will have high ESL and a 0805 ceramic chip capacitor will have very low ESL. At the operating frequencies of the LMR12010, certain capacitors may have an ESL so large that the resulting impedance ($2\pi fL$) will be higher than that required to provide stable operation. As a result, surface mount capacitors are strongly recommended. Sanyo POSCAP, Tantalum or Niobium, Panasonic SP or Cornell Dubilier ESR, and multilayer ceramic capacitors (MLCC) are all good choices for both input and output capacitors and have very low ESL. For MLCCs it is recommended to use X7R or X5R dielectrics. Consult capacitor manufacturer datasheet to see how rated capacitance varies over operating conditions.

Output Capacitor

The output capacitor is selected based upon the desired output ripple and transient response. The initial current of a load transient is provided mainly by the output capacitor. The output ripple of the converter is:

$$\Delta V_o = \Delta i_L \times \left(R_{ESR} + \frac{1}{8 \times f_s \times C_o} \right)$$

(20)

When using MLCCs, the ESR is typically so low that the capacitive ripple may dominate. When this occurs, the output ripple will be approximately sinusoidal and 90° phase shifted from the switching action. Given the availability and quality of MLCCs and the expected output voltage of designs using the LMR12010, there is really no need to review any other capacitor technologies. Another benefit of ceramic capacitors is their ability to bypass high frequency noise. A certain amount of switching edge noise will couple through parasitic capacitances in the inductor to the output. A ceramic capacitor will bypass this noise while a tantalum will not. Since the output capacitor is one of the two external components that control the stability of the regulator control loop, most applications will require a minimum at 10 μ F of output capacitance. Capacitance can be increased significantly with little detriment to the regulator stability. Like the input capacitor, recommended multilayer ceramic capacitors are X7R or X5R. Again, verify actual capacitance at the desired operating voltage and temperature.

Check the RMS current rating of the capacitor. The RMS current rating of the capacitor chosen must also meet the following condition:

$$I_{\text{RMS-OUT}} = I_O \times \frac{r}{\sqrt{12}} \quad (21)$$

Catch Diode

The catch diode (D1) conducts during the switch off-time. A Schottky diode is recommended for its fast switching times and low forward voltage drop. The catch diode should be chosen so that its current rating is greater than:

$$I_{D1} = I_O \times (1-D) \quad (22)$$

The reverse breakdown rating of the diode must be at least the maximum input voltage plus appropriate margin. To improve efficiency choose a Schottky diode with a low forward voltage drop.

BOOST Diode

A standard diode such as the 1N4148 type is recommended. For V_{BOOST} circuits derived from voltages less than 3.3V, a small-signal Schottky diode is recommended for greater efficiency. A good choice is the BAT54 small signal diode.

BOOST Capacitor

A ceramic 0.01 μF capacitor with a voltage rating of at least 6.3V is sufficient. The X7R and X5R MLCCs provide the best performance.

Output Voltage

The output voltage is set using the following equation where R2 is connected between the FB pin and GND, and R1 is connected between V_O and the FB pin. A good value for R2 is 10k Ω .

$$R1 = \left(\frac{V_O}{V_{\text{REF}}} - 1 \right) \times R2 \quad (23)$$

PCB Layout Considerations

When planning layout there are a few things to consider when trying to achieve a clean, regulated output. The most important consideration when completing the layout is the close coupling of the GND connections of the C_{IN} capacitor and the catch diode D1. These ground ends should be close to one another and be connected to the GND plane with at least two through-holes. Place these components as close to the IC as possible. Next in importance is the location of the GND connection of the C_{OUT} capacitor, which should be near the GND connections of C_{IN} and D1.

There should be a continuous ground plane on the bottom layer of a two-layer board except under the switching node island.

The FB pin is a high impedance node and care should be taken to make the FB trace short to avoid noise pickup and inaccurate regulation. The feedback resistors should be placed as close as possible to the IC, with the GND of R2 placed as close as possible to the GND of the IC. The V_{OUT} trace to R1 should be routed away from the inductor and any other traces that are switching.

High AC currents flow through the V_{IN} , SW and V_{OUT} traces, so they should be as short and wide as possible. However, making the traces wide increases radiated noise, so the designer must make this trade-off. Radiated noise can be decreased by choosing a shielded inductor.

The remaining components should also be placed as close as possible to the IC. Refer to the LMR12010 demo board as an example of a good layout.

Calculating Efficiency, and Junction Temperature

The complete LMR12010 DC/DC converter efficiency can be calculated in the following manner.

$$\eta = \frac{P_{OUT}}{P_{IN}} \quad (24)$$

Or

$$\eta = \frac{P_{OUT}}{P_{OUT} + P_{LOSS}} \quad (25)$$

Calculations for determining the most significant power losses are shown below. Other losses totaling less than 2% are not discussed.

Power loss (P_{LOSS}) is the sum of two basic types of losses in the converter, switching and conduction. Conduction losses usually dominate at higher output loads, where as switching losses remain relatively fixed and dominate at lower output loads. The first step in determining the losses is to calculate the duty cycle (D).

$$D = \frac{V_{OUT} + V_D}{V_{IN} + V_D - V_{SW}} \quad (26)$$

V_{SW} is the voltage drop across the internal NFET when it is on, and is equal to:

$$V_{SW} = I_{OUT} \times R_{DSON} \quad (27)$$

V_D is the forward voltage drop across the Schottky diode. It can be obtained from the [Electrical Characteristics](#) section. If the voltage drop across the inductor (V_{DCR}) is accounted for, the equation becomes:

$$D = \frac{V_O + V_D + V_{DCR}}{V_{IN} + V_D - V_{SW}} \quad (28)$$

This usually gives only a minor duty cycle change, and has been omitted in the examples for simplicity.

The conduction losses in the free-wheeling Schottky diode are calculated as follows:

$$P_{DIODE} = V_D \times I_{OUT}(1-D) \quad (29)$$

Often this is the single most significant power loss in the circuit. Care should be taken to choose a Schottky diode that has a low forward voltage drop.

Another significant external power loss is the conduction loss in the output inductor. The equation can be simplified to:

$$P_{IND} = I_{OUT}^2 \times R_{DCR} \quad (30)$$

The LMR12010 conduction loss is mainly associated with the internal NFET:

$$P_{COND} = I_{OUT}^2 \times R_{DSON} \times D \quad (31)$$

Switching losses are also associated with the internal NFET. They occur during the switch on and off transition periods, where voltages and currents overlap resulting in power loss. The simplest means to determine this loss is to empirically measuring the rise and fall times (10% to 90%) of the switch at the switch node:

$$P_{SWF} = 1/2(V_{IN} \times I_{OUT} \times \text{freq} \times T_{FALL}) \quad (32)$$

$$P_{SWR} = 1/2(V_{IN} \times I_{OUT} \times \text{freq} \times T_{RISE}) \quad (33)$$

$$P_{SW} = P_{SWF} + P_{SWR} \quad (34)$$

Table 1. Typical Rise and Fall Times vs Input Voltage

V_{IN}	T_{RISE}	T_{FALL}
5V	8ns	4ns
10V	9ns	6ns
15V	10ns	7ns

Another loss is the power required for operation of the internal circuitry:

$$P_Q = I_Q \times V_{IN} \quad (35)$$

I_Q is the quiescent operating current, and is typically around 1.5mA. The other operating power that needs to be calculated is that required to drive the internal NFET:

$$P_{BOOST} = I_{BOOST} \times V_{BOOST} \quad (36)$$

V_{BOOST} is normally between 3VDC and 5VDC. The I_{BOOST} rms current is approximately 4.25mA. Total power losses are:

$$\Sigma P_{COND} + P_{SW} + P_{DIODE} + P_{IND} + P_Q + P_{BOOST} = P_{LOSS} \quad (37)$$

Design Example 1:			
Operating Conditions			
V_{IN}	5.0V	P_{OUT}	2.5W
V_{OUT}	2.5V	P_{DIODE}	151mW
I_{OUT}	1.0A	P_{IND}	75mW
V_D	0.35V	P_{SWF}	53mW
Freq	3MHz	P_{SWR}	53mW
I_Q	1.5mA	P_{COND}	187mW
T_{RISE}	8ns	P_Q	7.5mW
T_{FALL}	8ns	P_{BOOST}	21mW
R_{DSON}	330mΩ	P_{LOSS}	548mW
IND_{DCR}	75mΩ		
D	0.568		

$\eta = 82\%$

Calculating the LMR12010 Junction Temperature

Thermal Definitions:

T_J = Chip junction temperature

T_A = Ambient temperature

$R_{\theta JC}$ = Thermal resistance from chip junction to device case

$R_{\theta JA}$ = Thermal resistance from chip junction to ambient air

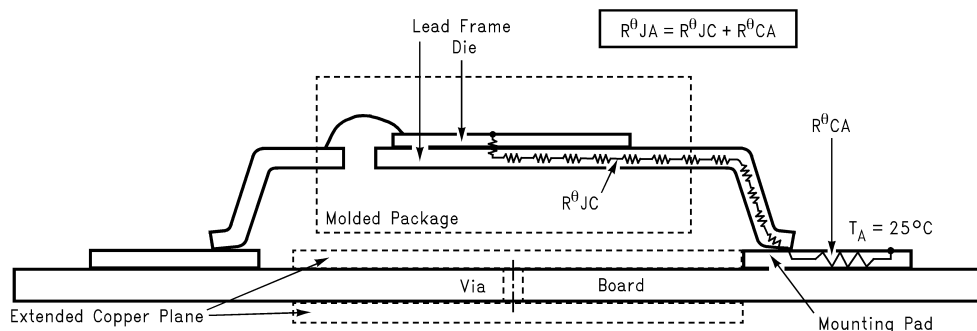

Figure 27. Cross-Sectional View of Integrated Circuit Mounted on a Printed Circuit Board.

Heat in the LMR12010 due to internal power dissipation is removed through conduction and/or convection.

Conduction: Heat transfer occurs through cross sectional areas of material. Depending on the material, the transfer of heat can be considered to have poor to good thermal conductivity properties (insulator vs conductor).

Heat Transfer goes as:

silicon → package → lead frame → PCB.

Convection: Heat transfer is by means of airflow. This could be from a fan or natural convection. Natural convection occurs when air currents rise from the hot device to cooler air.

Thermal impedance is defined as:

$$R_{\theta} = \frac{\Delta T}{Power} \quad (38)$$

Thermal impedance from the silicon junction to the ambient air is defined as:

$$R_{\theta JA} = \frac{T_J - T_A}{\text{Power}} \quad (39)$$

This impedance can vary depending on the thermal properties of the PCB. This includes PCB size, weight of copper used to route traces and ground plane, and number of layers within the PCB. The type and number of thermal vias can also make a large difference in the thermal impedance. Thermal vias are necessary in most applications. They conduct heat from the surface of the PCB to the ground plane. Place two to four thermal vias close to the ground pin of the device.

The datasheet specifies two different $R_{\theta JA}$ numbers for the Thin SOT-23-6 package. The two numbers show the difference in thermal impedance for a four-layer board with 2oz. copper traces, vs. a four-layer board with 1oz. copper. $R_{\theta JA}$ equals 120°C/W for 2oz. copper traces and GND plane, and 235°C/W for 1oz. copper traces and GND plane.

Method 1:

To accurately measure the silicon temperature for a given application, two methods can be used. The first method requires the user to know the thermal impedance of the silicon junction to case. ($R_{\theta JC}$) is approximately 80°C/W for the Thin SOT-23-6 package. Knowing the internal dissipation from the efficiency calculation given previously, and the case temperature, which can be empirically measured on the bench we have:

$$R_{\theta JA} = \frac{T_J - T_C}{\text{Power}} \quad (40)$$

Therefore:

$$T_J = (R_{\theta JC} \times P_{\text{LOSS}}) + T_C \quad (41)$$

	Design Example 2:		
		Operating Conditions	
V_{IN}	5.0V	P_{OUT}	2.5W
V_{OUT}	2.5V	P_{DIODE}	151mW
I_{OUT}	1.0A	P_{IND}	75mW
V_D	0.35V	P_{SWF}	53mW
Freq	3MHz	P_{SWR}	53mW
I_Q	1.5mA	P_{COND}	187mW
T_{RISE}	8ns	P_Q	7.5mW
T_{FALL}	8ns	P_{BOOST}	21mW
R_{DSON}	330mΩ	P_{LOSS}	548mW
IND_{DCR}	75mΩ		
D	0.568		

$$\Sigma P_{COND} + P_{SWF} + P_{SWR} + P_Q + P_{BOOST} = P_{INTERNAL}$$

$$P_{INTERNAL} = \mathbf{322\ mW}$$

$$T_J = (R_{\theta JC} \times \text{Power}) + T_C = 80^\circ\text{C/W} \times 322\ \text{mW} + T_C \quad (42)$$

The second method can give a very accurate silicon junction temperature. The first step is to determine $R_{\theta JA}$ of the application. The LMR12010 has over-temperature protection circuitry. When the silicon temperature reaches 165°C, the device stops switching. The protection circuitry has a hysteresis of 15°C. Once the silicon temperature has decreased to approximately 150°C, the device will start to switch again. Knowing this, the $R_{\theta JA}$ for any PCB can be characterized during the early stages of the design by raising the ambient temperature in the given application until the circuit enters thermal shutdown. If the SW-pin is monitored, it will be obvious when the internal NFET stops switching indicating a junction temperature of 165°C. Knowing the internal power dissipation from the above methods, the junction temperature and the ambient temperature, $R_{\theta JA}$ can be determined.

$$R_{\theta JA} = \frac{165^\circ\text{C} - T_A}{P_{INTERNAL}} \quad (43)$$

Once this is determined, the maximum ambient temperature allowed for a desired junction temperature can be found.

Design Example 3:			
Operating Conditions			
Package	SOT-23-6		
V _{IN}	12.0V	P _{OUT}	2.475W
V _{OUT}	3.30V	P _{DIODE}	523mW
I _{OUT}	750mA	P _{IND}	56.25mW
V _D	0.35V	P _{SWF}	108mW
Freq	3MHz	P _{SWR}	108mW
I _Q	1.5mA	P _{COND}	68.2mW
I _{BOOST}	4mA	P _Q	18mW
V _{BOOST}	5V	P _{BOOST}	20mW
T _{RISE}	8ns	P _{LOSS}	902mW
T _{FALL}	8ns		
R _{DSON}	400mΩ		
IND _{DCR}	75mΩ		
D	30.3%		

$$\Sigma P_{\text{COND}} + P_{\text{SWF}} + P_{\text{SWR}} + P_{\text{Q}} + P_{\text{BOOST}} = P_{\text{INTERNAL}}$$

$$P_{\text{INTERNAL}} = \mathbf{322 \text{ mW}} \quad (44)$$

Using a standard TI Thin SOT-23-6 demonstration board to determine the $R_{\theta\text{JA}}$ of the board. The four layer PCB is constructed using FR4 with 1/2oz copper traces. The copper ground plane is on the bottom layer. The ground plane is accessed by two vias. The board measures 2.5cm x 3cm. It was placed in an oven with no forced airflow.

The ambient temperature was raised to 94°C, and at that temperature, the device went into thermal shutdown.

$$R_{\theta\text{JA}} = \frac{165^{\circ}\text{C} - 94^{\circ}\text{C}}{322 \text{ mW}} = 220^{\circ}\text{C/W} \quad (45)$$

If the junction temperature was to be kept below 125°C, then the ambient temperature cannot go above 54.2°C.

$$T_{\text{J}} - (R_{\theta\text{JA}} \times P_{\text{LOSS}}) = T_{\text{A}} \quad (46)$$

PACKAGING INFORMATION

Orderable Device	Status (1)	Package Type	Package Drawing	Pins	Package Qty	Eco Plan (2)	Lead/Ball Finish	MSL Peak Temp (3)	Op Temp (°C)	Top-Side Markings (4)	Samples
LMR12010XMK/NOPB	ACTIVE	SOT	DDC	6	1000	Green (RoHS & no Sb/Br)	CU SN	Level-1-260C-UNLIM	-40 to 125	SF7B	Samples
LMR12010XMKE/NOPB	ACTIVE	SOT	DDC	6	250	Green (RoHS & no Sb/Br)	CU SN	Level-1-260C-UNLIM	-40 to 125	SF7B	Samples
LMR12010XMKX/NOPB	ACTIVE	SOT	DDC	6	3000	Green (RoHS & no Sb/Br)	CU SN	Level-1-260C-UNLIM	-40 to 125	SF7B	Samples
LMR12010YMK/NOPB	ACTIVE	SOT	DDC	6	1000	Green (RoHS & no Sb/Br)	CU SN	Level-1-260C-UNLIM	-40 to 125	SF8B	Samples
LMR12010YMKE/NOPB	ACTIVE	SOT	DDC	6	250	Green (RoHS & no Sb/Br)	CU SN	Level-1-260C-UNLIM	-40 to 125	SF8B	Samples
LMR12010YMKX/NOPB	ACTIVE	SOT	DDC	6	3000	Green (RoHS & no Sb/Br)	CU SN	Level-1-260C-UNLIM	-40 to 125	SF8B	Samples

(1) The marketing status values are defined as follows:

ACTIVE: Product device recommended for new designs.

LIFEBUY: TI has announced that the device will be discontinued, and a lifetime-buy period is in effect.

NRND: Not recommended for new designs. Device is in production to support existing customers, but TI does not recommend using this part in a new design.

PREVIEW: Device has been announced but is not in production. Samples may or may not be available.

OBSELETE: TI has discontinued the production of the device.

(2) Eco Plan - The planned eco-friendly classification: Pb-Free (RoHS), Pb-Free (RoHS Exempt), or Green (RoHS & no Sb/Br) - please check <http://www.ti.com/productcontent> for the latest availability information and additional product content details.

TBD: The Pb-Free/Green conversion plan has not been defined.

Pb-Free (RoHS): TI's terms "Lead-Free" or "Pb-Free" mean semiconductor products that are compatible with the current RoHS requirements for all 6 substances, including the requirement that lead not exceed 0.1% by weight in homogeneous materials. Where designed to be soldered at high temperatures, TI Pb-Free products are suitable for use in specified lead-free processes.

Pb-Free (RoHS Exempt): This component has a RoHS exemption for either 1) lead-based flip-chip solder bumps used between the die and package, or 2) lead-based die adhesive used between the die and leadframe. The component is otherwise considered Pb-Free (RoHS compatible) as defined above.

Green (RoHS & no Sb/Br): TI defines "Green" to mean Pb-Free (RoHS compatible), and free of Bromine (Br) and Antimony (Sb) based flame retardants (Br or Sb do not exceed 0.1% by weight in homogeneous material)

(3) MSL, Peak Temp. -- The Moisture Sensitivity Level rating according to the JEDEC industry standard classifications, and peak solder temperature.

(4) Multiple Top-Side Markings will be inside parentheses. Only one Top-Side Marking contained in parentheses and separated by a "~" will appear on a device. If a line is indented then it is a continuation of the previous line and the two combined represent the entire Top-Side Marking for that device.

Important Information and Disclaimer: The information provided on this page represents TI's knowledge and belief as of the date that it is provided. TI bases its knowledge and belief on information provided by third parties, and makes no representation or warranty as to the accuracy of such information. Efforts are underway to better integrate information from third parties. TI has taken and continues to take reasonable steps to provide representative and accurate information but may not have conducted destructive testing or chemical analysis on incoming materials and chemicals. TI and TI suppliers consider certain information to be proprietary, and thus CAS numbers and other limited information may not be available for release.

In no event shall TI's liability arising out of such information exceed the total purchase price of the TI part(s) at issue in this document sold by TI to Customer on an annual basis.

DDC (R-PDSO-G6)

PLASTIC SMALL-OUTLINE

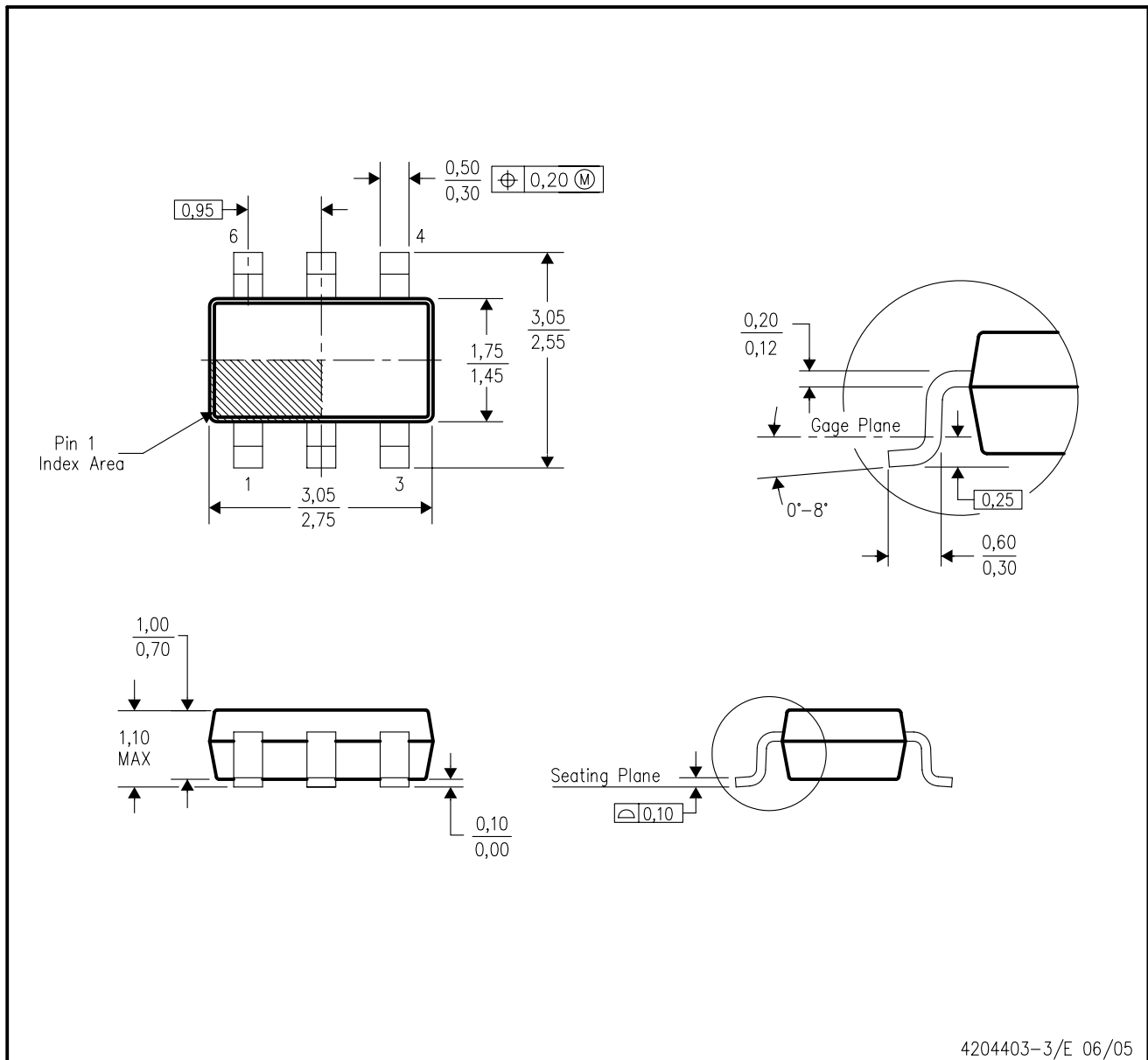

- NOTES:
- All linear dimensions are in millimeters.
 - This drawing is subject to change without notice.
 - Body dimensions do not include mold flash or protrusion.
 - Falls within JEDEC MO-193 variation AA (6 pin).

DDC (R-PDSO-G6)

PLASTIC SMALL OUTLINE

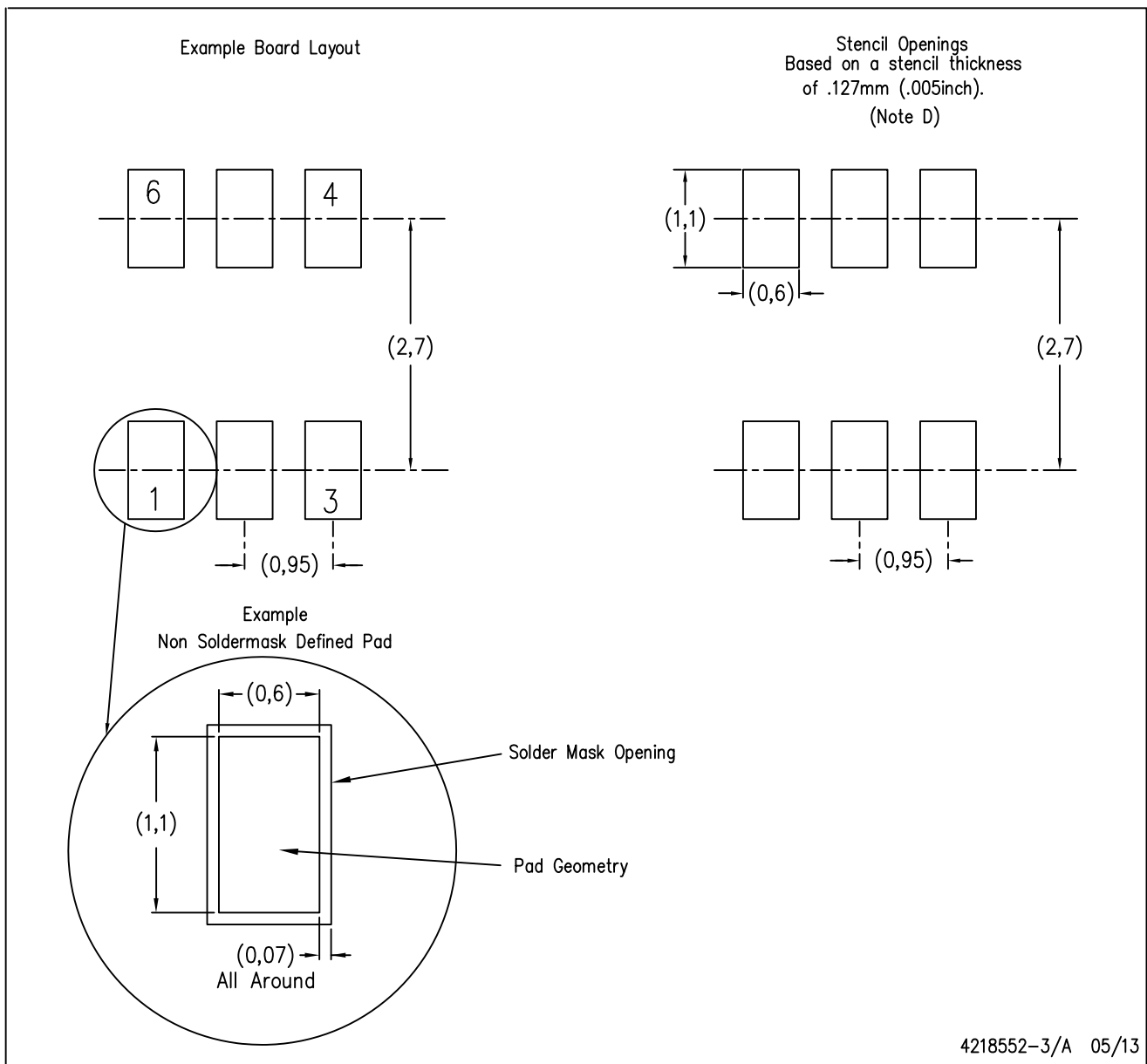

- NOTES:
- A. All linear dimensions are in millimeters.
 - B. This drawing is subject to change without notice.
 - C. Publication IPC-7351 is recommended for alternate designs.
 - D. Laser cutting apertures with trapezoidal walls and also rounding corners will offer better paste release. Customers should contact their board assembly site for stencil design recommendations. Example stencil design based on a 50% volumetric metal load solder paste. Refer to IPC-7525 for other stencil recommendations.

IMPORTANT NOTICE

Texas Instruments Incorporated and its subsidiaries (TI) reserve the right to make corrections, enhancements, improvements and other changes to its semiconductor products and services per JESD46, latest issue, and to discontinue any product or service per JESD48, latest issue. Buyers should obtain the latest relevant information before placing orders and should verify that such information is current and complete. All semiconductor products (also referred to herein as "components") are sold subject to TI's terms and conditions of sale supplied at the time of order acknowledgment.

TI warrants performance of its components to the specifications applicable at the time of sale, in accordance with the warranty in TI's terms and conditions of sale of semiconductor products. Testing and other quality control techniques are used to the extent TI deems necessary to support this warranty. Except where mandated by applicable law, testing of all parameters of each component is not necessarily performed.

TI assumes no liability for applications assistance or the design of Buyers' products. Buyers are responsible for their products and applications using TI components. To minimize the risks associated with Buyers' products and applications, Buyers should provide adequate design and operating safeguards.

TI does not warrant or represent that any license, either express or implied, is granted under any patent right, copyright, mask work right, or other intellectual property right relating to any combination, machine, or process in which TI components or services are used. Information published by TI regarding third-party products or services does not constitute a license to use such products or services or a warranty or endorsement thereof. Use of such information may require a license from a third party under the patents or other intellectual property of the third party, or a license from TI under the patents or other intellectual property of TI.

Reproduction of significant portions of TI information in TI data books or data sheets is permissible only if reproduction is without alteration and is accompanied by all associated warranties, conditions, limitations, and notices. TI is not responsible or liable for such altered documentation. Information of third parties may be subject to additional restrictions.

Resale of TI components or services with statements different from or beyond the parameters stated by TI for that component or service voids all express and any implied warranties for the associated TI component or service and is an unfair and deceptive business practice. TI is not responsible or liable for any such statements.

Buyer acknowledges and agrees that it is solely responsible for compliance with all legal, regulatory and safety-related requirements concerning its products, and any use of TI components in its applications, notwithstanding any applications-related information or support that may be provided by TI. Buyer represents and agrees that it has all the necessary expertise to create and implement safeguards which anticipate dangerous consequences of failures, monitor failures and their consequences, lessen the likelihood of failures that might cause harm and take appropriate remedial actions. Buyer will fully indemnify TI and its representatives against any damages arising out of the use of any TI components in safety-critical applications.

In some cases, TI components may be promoted specifically to facilitate safety-related applications. With such components, TI's goal is to help enable customers to design and create their own end-product solutions that meet applicable functional safety standards and requirements. Nonetheless, such components are subject to these terms.

No TI components are authorized for use in FDA Class III (or similar life-critical medical equipment) unless authorized officers of the parties have executed a special agreement specifically governing such use.

Only those TI components which TI has specifically designated as military grade or "enhanced plastic" are designed and intended for use in military/aerospace applications or environments. Buyer acknowledges and agrees that any military or aerospace use of TI components which have **not** been so designated is solely at the Buyer's risk, and that Buyer is solely responsible for compliance with all legal and regulatory requirements in connection with such use.

TI has specifically designated certain components as meeting ISO/TS16949 requirements, mainly for automotive use. In any case of use of non-designated products, TI will not be responsible for any failure to meet ISO/TS16949.

Products

Audio	www.ti.com/audio
Amplifiers	amplifier.ti.com
Data Converters	dataconverter.ti.com
DLP® Products	www.dlp.com
DSP	dsp.ti.com
Clocks and Timers	www.ti.com/clocks
Interface	interface.ti.com
Logic	logic.ti.com
Power Mgmt	power.ti.com
Microcontrollers	microcontroller.ti.com
RFID	www.ti-rfid.com
OMAP Applications Processors	www.ti.com/omap
Wireless Connectivity	www.ti.com/wirelessconnectivity

Applications

Automotive and Transportation	www.ti.com/automotive
Communications and Telecom	www.ti.com/communications
Computers and Peripherals	www.ti.com/computers
Consumer Electronics	www.ti.com/consumer-apps
Energy and Lighting	www.ti.com/energy
Industrial	www.ti.com/industrial
Medical	www.ti.com/medical
Security	www.ti.com/security
Space, Avionics and Defense	www.ti.com/space-avionics-defense
Video and Imaging	www.ti.com/video

TI E2E Community

e2e.ti.com