

3.3-V CAN TRANSCEIVERS

FEATURES

- **Controlled Baseline**
 - One Assembly/Test Site, One Fabrication Site
- **Extended Temperature Performance of -55°C to 125°C**
- **Enhanced Diminishing Manufacturing Sources (DMS) Support**
- **Enhanced Product-Change Notification**
- **Qualification Pedigree†**
- **Operates With a 3.3-V Supply**
- **Low Power Replacement for the PCA82C250 Footprint**
- **Bus/Pin ESD Protection Exceeds 15-kV HBM**
- **Controlled Driver Output Transition Times for Improved Signal Quality on the SN65HVD230M**
- **Unpowered Node Does Not Disturb the Bus**
- **Compatible With the Requirements of the ISO 11898 Standard**

- **Low-Current SN65HVD230M Standby Mode $370\ \mu\text{A}$ Typical**
- **Designed for Signaling Rates‡ Up To 1 Megabit/Second (Mbps)**
- **Thermal Shutdown Protection**
- **Open-Circuit Fail-Safe Design**

† Component qualification in accordance with JEDEC and industry standards to ensure reliable operation over an extended temperature range. This includes, but is not limited to, Highly Accelerated Stress Test (HAST) or biased 85/85, temperature cycle, autoclave or unbiased HAST, electromigration, bond intermetallic life, and mold compound life. Such qualification testing should not be viewed as justifying use of this component beyond specified performance and environmental limits.

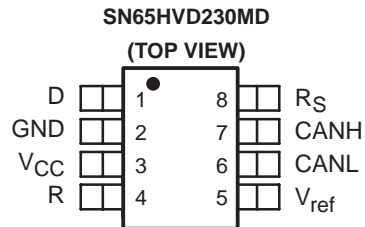

logic diagram (positive logic)

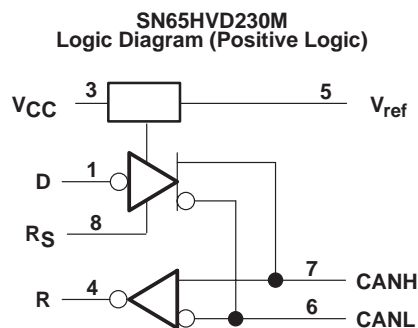

Please be aware that an important notice concerning availability, standard warranty, and use in critical applications of Texas Instruments semiconductor products and disclaimers thereto appears at the end of this data sheet.

‡ The signaling rate of a line is the number of voltage transitions that are made per second expressed in the units bps (bits per second).

DESCRIPTION

The SN65HVD230M controller area network (CAN) transceiver is designed for use with the Texas Instruments TMS320Lx240x 3.3-V DSPs with CAN controllers, or with equivalent devices. They are intended for use in applications employing the CAN serial communication physical layer in accordance with the ISO 11898 standard. Each CAN transceiver is designed to provide differential transmit capability to the bus and differential receive capability to a CAN controller at speeds up to 1 Mbps.

Designed for operation in especially-harsh environments, these devices feature cross-wire protection, loss-of-ground and overvoltage protection, overtemperature protection, as well as wide common-mode range.

The transceiver interfaces the single-ended CAN controller with the differential CAN bus found in industrial, building automation, and automotive applications. It operates over a -2-V to 7-V common-mode range on the bus and it can withstand common-mode transients of $\pm 25\text{ V}$.

On the SN65HVD230M, R_S (pin 8) provides three different modes of operation: high-speed, slope control, and low-power modes. The high-speed mode of operation is selected by connecting pin 8 to ground, allowing the transmitter output transistors to switch on and off as fast as possible with no limitation on the rise and fall slopes. The rise and fall slopes can be adjusted by connecting a resistor to ground at pin 8, since the slope is proportional to the pin's output current. This slope control is implemented with external resistor values of $10\text{ k}\Omega$, to achieve a $15\text{-V}/\mu\text{s}$ slew rate, to $100\text{ k}\Omega$, to achieve a $2\text{-V}/\mu\text{s}$ slew rate.

The circuit of the SN65HVD230M enters a low-current standby mode during which the driver is switched off and the receiver remains active if a high logic level is applied to R_S (pin 8). The DSP controller reverses this low-current standby mode when a dominant state (bus differential voltage $> 900\text{ mV}$ typical) occurs on the bus.

The V_{ref} (pin 5 on the SN65HVD230M) is available as a $V_{\text{CC}}/2$ voltage reference.

AVAILABLE OPTIONS

FUNCTION NUMBER	LOW POWER MODE	INTEGRATED SLOPE CONTROL	Vref PIN
'230	370- μA standby mode	Yes	Yes

PART NUMBER	Q100	T_A	MARKED AS
SN65HVD230MDREP	No	-55°C to 125°C	HV230M

Function Tables
DRIVER (SN65HVD230M)

INPUT D	R _S	OUTPUTS		BUS STATE
		CANH	CANL	
L	V _(RS) < 1.2 V	H	L	Dominant
H		Z	Z	Recessive
Open	X	Z	Z	Recessive
X	V _(RS) > 0.75 V _{CC}	Z	Z	Recessive

H = high level; L = low level; X = irrelevant; ? = indeterminate

RECEIVER (SN65HVD230M)

DIFFERENTIAL INPUTS	R _S	OUTPUT R
V _{ID} ≥ 0.9 V	X	L
0.5 V < V _{ID} < 0.9 V	X	?
V _{ID} ≤ 0.5 V	X	H
Open	X	H

H = high level; L = low level; X = irrelevant; ? = indeterminate

TRANSCEIVER MODES (SN65HVD230M)

V _(RS)	OPERATING MODE
V _(RS) > 0.75 V _{CC}	Standby
10 kΩ to 100 kΩ to ground	Slope control
V _(RS) < 1 V	High speed (no slope control)

Terminal Functions

SN65HVD230M		
TERMINAL NAME	NO.	DESCRIPTION
CANL	6	Low bus output
CANH	7	High bus output
D	1	Driver input
GND	2	Ground
R	4	Receiver output
R _S	8	Standby/slope control
V _{CC}	3	Supply voltage
V _{ref}	5	Reference output

SN65HVD230M-EP

SGLS356 – MAY 2006

equivalent input and output schematic diagrams

CANH and CANL Inputs

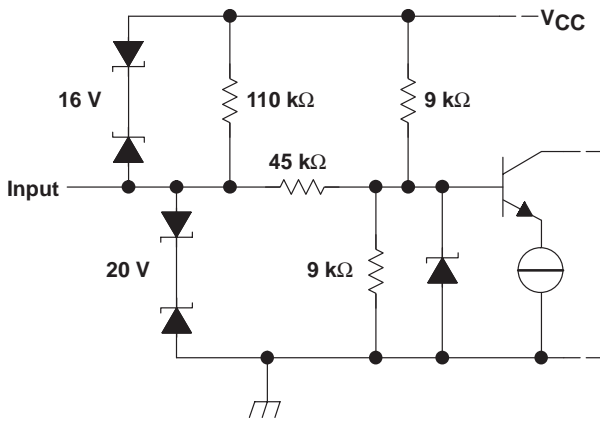

D Input

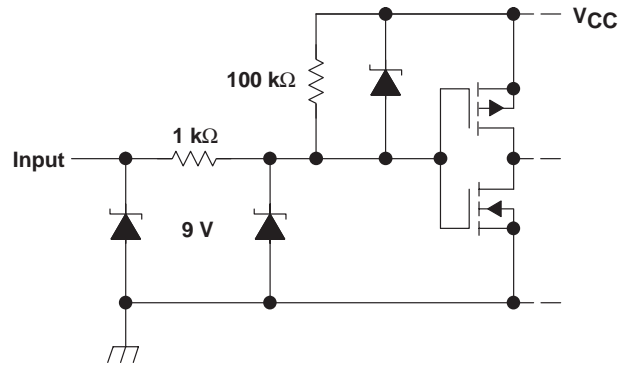

CANH and CANL Outputs

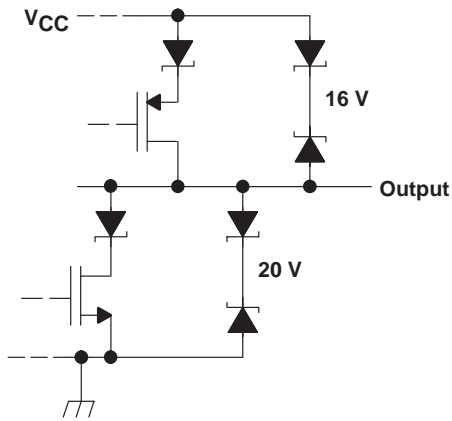

R Output

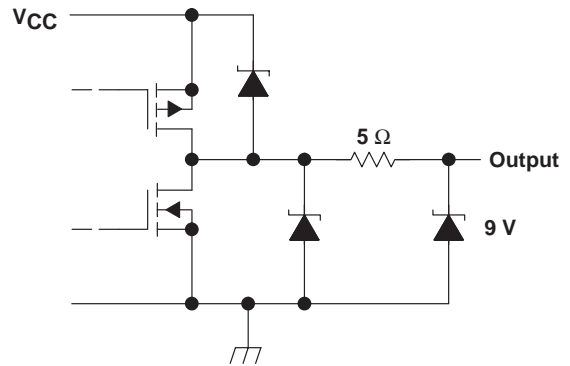

SN65HVD230M-EP

SGLS356 – MAY 2006

driver electrical characteristics over recommended operating conditions (unless otherwise noted)

PARAMETER			TEST CONDITIONS			MIN	TYP†	MAX	UNIT
V _{OH}	Bus output voltage	Dominant	V _I = 0 V, See Figure 1 and Figure 3		CANH	2.45	V _{CC}		V
					CANL	0.5	1.25		
V _{OL}		Recessive	V _I = 3 V, See Figure 1 and Figure 3		CANH	2.3			
					CANL	2.3			
V _{OD(D)}	Differential output voltage	Dominant	V _I = 0 V, See Figure 1		1.5	2	3	V	
			V _I = 0 V, See Figure 2		1.2	2	3		
V _{OD(R)}		Recessive	V _I = 3 V, See Figure 1		-120	0	12	mV	
			V _I = 3 V, No load		-0.5	-0.2	0.05	V	
I _{IH}	High-level input current		V _I = 2 V			-30		μA	
I _{IL}	Low-level input current		V _I = 0.8 V			-30		μA	
I _{OS}	Short-circuit output current		V _{CANH} = -2 V			-250	250		mA
			V _{CANL} = 7 V			-250	250		
C _o	Output capacitance		See receiver						
I _{CC}	Supply current	Standby	SN65HVD230M		V _(RS) = V _{CC}		370	600	μA
		All devices	Dominant	V _I = 0 V, No load		Dominant	10	17	mA
			Recessive	V _I = V _{CC} , No load		Recessive	10	17	

† All typical values are at 25°C and with a 3.3-V supply.

driver switching characteristics at T_A = 25°C (unless otherwise noted)

PARAMETER		TEST CONDITIONS			MIN	TYP	MAX	UNIT
t _{PLH}	Propagation delay time, low-to-high-level output	V _(RS) = 0 V			35	85		ns
		R _S with 10 kΩ to ground			70	190		
		R _S with 100 kΩ to ground			500	870		
t _{PHL}	Propagation delay time, high-to-low-level output	V _(RS) = 0 V			70	130		ns
		R _S with 10 kΩ to ground			130	205		
		R _S with 100 kΩ to ground			870	1200		
t _{sk(p)}	Pulse skew (t _{P(HL)} - t _{P(LH)})	V _(RS) = 0 V			35			ns
		R _S with 10 kΩ to ground			60			
		R _S with 100 kΩ to ground			370			
t _r	Differential output signal rise time	V _(RS) = 0 V			25	50	100	ns
t _f	Differential output signal fall time	V _(RS) = 0 V			40	55	80	ns
t _r	Differential output signal rise time	R _S with 10 kΩ to ground			75	120	160	ns
t _f	Differential output signal fall time				80	125	150	ns
t _r	Differential output signal rise time	R _S with 100 kΩ to ground			350	800	1200	ns
t _f	Differential output signal fall time				600	825	1200	ns

receiver electrical characteristics over recommended operating conditions (unless otherwise noted)

PARAMETER		TEST CONDITIONS	MIN	TYP†	MAX	UNIT
V _{IT+}	Positive-going input threshold voltage	See Table 1		750	900	mV
V _{IT-}	Negative-going input threshold voltage			500	650	mV
V _{hys}	Hysteresis voltage (V _{IT+} – V _{IT-})			100		
V _{OH}	High-level output voltage	-6 V ≤ V _{ID} ≤ 500 mV, I _O = -8 mA, See Figure 5	2.4			V
V _{OL}	Low-level output voltage	900 mV ≤ V _{ID} ≤ 6 V, I _O = 8 mA, See Figure 5			0.4	
I _I	Bus input current	V _{IH} = 7 V	Other input at 0 V, D = 3 V	100	250	μA
		V _{IH} = 7 V, V _{CC} = 0 V		100	350	
		V _{IH} = -2 V		-200	-30	μA
		V _{IH} = -2 V, V _{CC} = 0 V		-100	-20	
C _i	CANH, CANL input capacitance	Pin-to-ground, V _I = 0.4 sin(4E6πt) + 0.5 V	V _(D) = 3 V,		32	pF
C _{diff}	Differential input capacitance	Pin-to-pin, V _I = 0.4 sin(4E6πt) + 0.5 V	V _(D) = 3 V,		16	pF
R _{diff}	Differential input resistance	Pin-to-pin, V _(D) = 3 V	40	70	100	kΩ
R _T	CANH, CANL input resistance		20	35	50	kΩ
I _{CC}	Supply current	See driver				

† All typical values are at 25°C and with a 3.3-V supply.

receiver switching characteristics at T_A = 25°C (unless otherwise noted)

PARAMETER		TEST CONDITIONS	MIN	TYP	MAX	UNIT
t _{PLH}	Propagation delay time, low-to-high-level output	See Figure 6		35	55	ns
t _{PHL}	Propagation delay time, high-to-low-level output			35	55	
t _{sk(p)}	Pulse skew (t _{P(HL)} – t _{P(LH)})				10	
t _r	Output signal rise time	See Figure 6		1.5		ns
t _f	Output signal fall time			1.5		
t _(loop)	Total loop delay, driver input to receiver output	V _(RS) = 0 V		70	135	ns
t _(loop)	Total loop delay, driver input to receiver output	R _S with 10 kΩ to ground		105	175	
t _(loop)	Total loop delay, driver input to receiver output	R _S with 100 kΩ to ground		535	920	

device control-pin characteristics over recommended operating conditions (unless otherwise noted)

PARAMETER	TEST CONDITIONS	MIN	TYP†	MAX	UNIT
$t_{(WAKE)}$	SN65HVD230M wake-up time from standby mode with R_S		0.55	1.5	μS
V_{ref}	Reference output voltage	$-5 \mu A < I(V_{ref}) < 5 \mu A$		$0.45 V_{CC}$	$0.55 V_{CC}$
		$-50 \mu A < I(V_{ref}) < 50 \mu A$		$0.4 V_{CC}$	$0.6 V_{CC}$
$I_{(RS)}$	Input current for high-speed			0	μA

† All typical values are at 25°C and with a 3.3 V supply.

PARAMETER MEASUREMENT INFORMATION

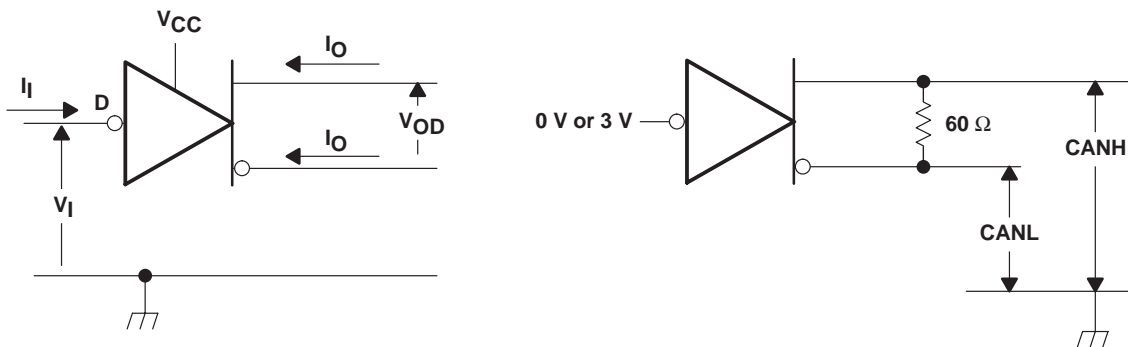

Figure 1. Driver Voltage and Current Definitions

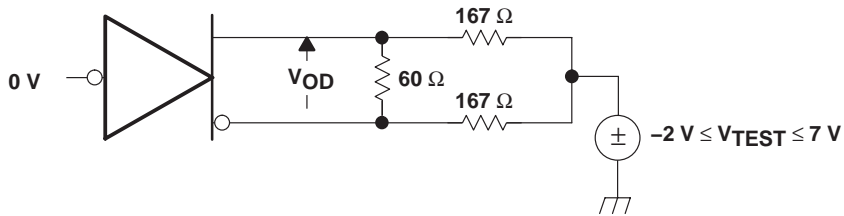

Figure 2. Driver V_{OD}

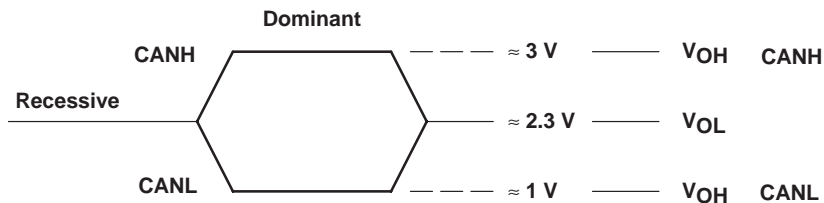
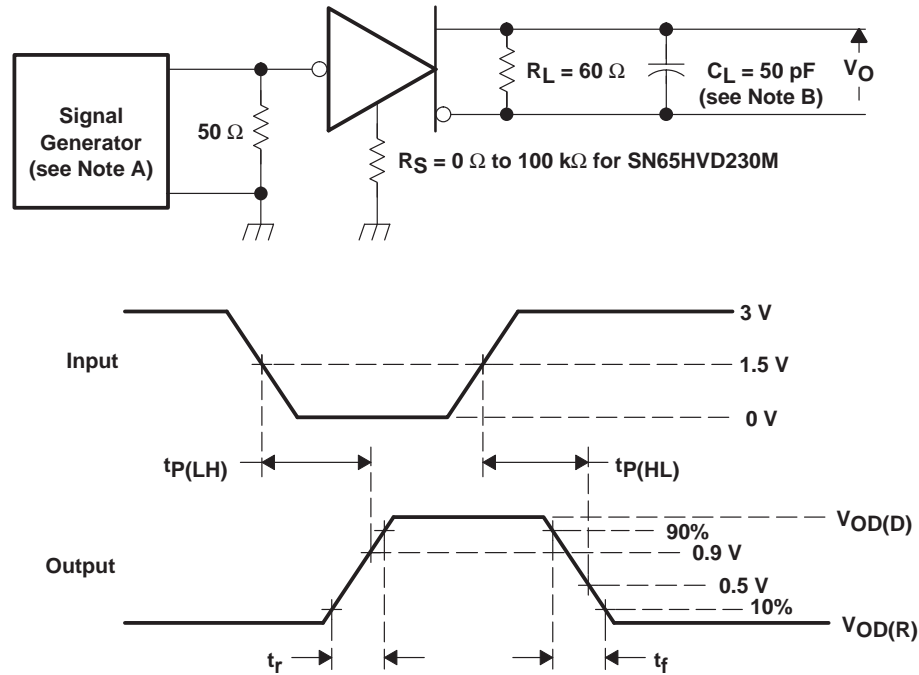

Figure 3. Driver Output Voltage Definitions

PARAMETER MEASUREMENT INFORMATION



- NOTES: A. The input pulse is supplied by a generator having the following characteristics: PRR ≤ 500 kHz, 50% duty cycle, $t_r \leq 6$ ns, $t_f \leq 6$ ns, $Z_0 = 50 \Omega$.
 B. C_L includes probe and jig capacitance.

Figure 4. Driver Test Circuit and Voltage Waveforms

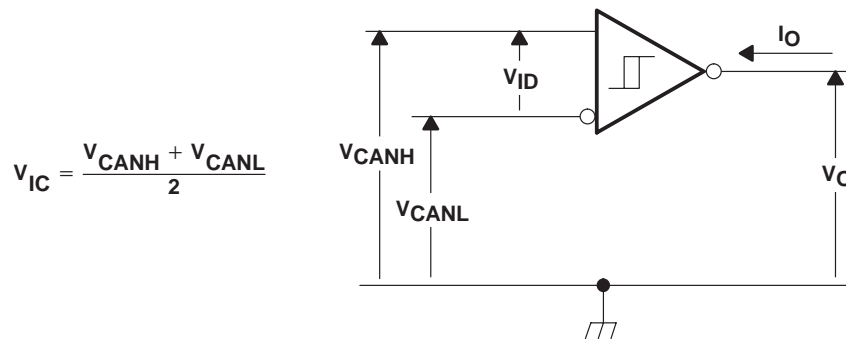
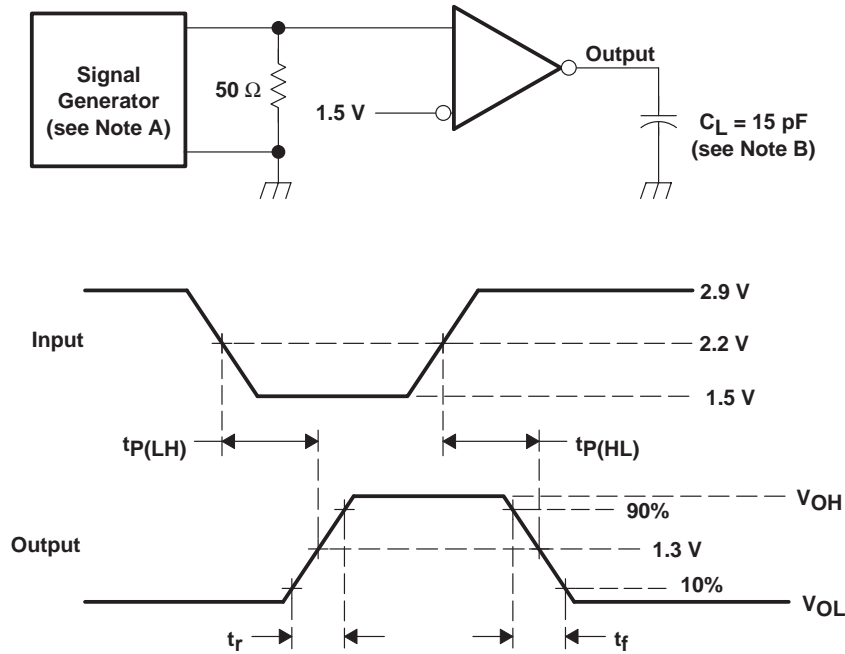

Figure 5. Receiver Voltage and Current Definitions

PARAMETER MEASUREMENT INFORMATION



- NOTES: A. The input pulse is supplied by a generator having the following characteristics: $PRR \leq 500 \text{ kHz}$, 50% duty cycle, $t_r \leq 6 \text{ ns}$, $t_f \leq 6 \text{ ns}$, $Z_o = 50 \Omega$.
 B. C_L includes probe and jig capacitance.

Figure 6. Receiver Test Circuit and Voltage Waveforms

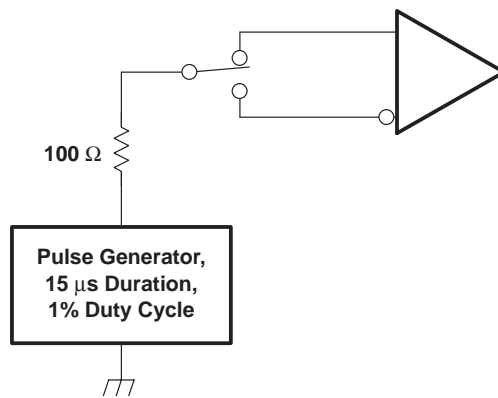
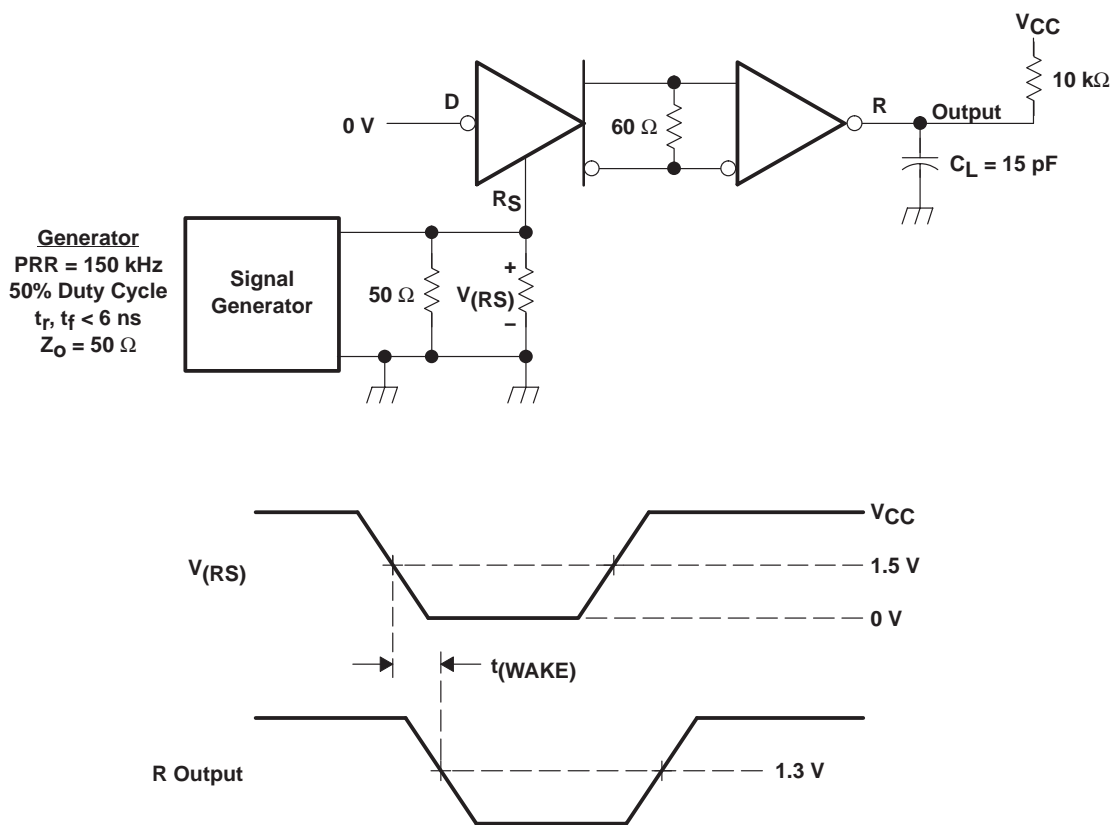

Figure 7. Overvoltage Protection

PARAMETER MEASUREMENT INFORMATION

Table 1. Receiver Characteristics Over Common Mode With V(RS) at 1.2 V

V _{IC}	V _{ID}	V _{CANH}	V _{CANL}	R OUTPUT	
-2 V	900 mV	-1.55 V	-2.45 V	L	V _{OL}
7 V	900 mV	8.45 V	6.55 V	L	
1 V	6 V	4 V	-2 V	L	
4 V	6 V	7 V	1 V	L	
-2 V	500 mV	-1.75 V	-2.25 V	H	V _{OH}
7 V	500 mV	7.25 V	6.75 V	H	
1 V	-6 V	-2 V	4 V	H	
4 V	-6 V	1 V	7 V	H	
X	X	Open	Open	H	



TYPICAL CHARACTERISTICS

SUPPLY CURRENT (RMS)
vs
FREQUENCY

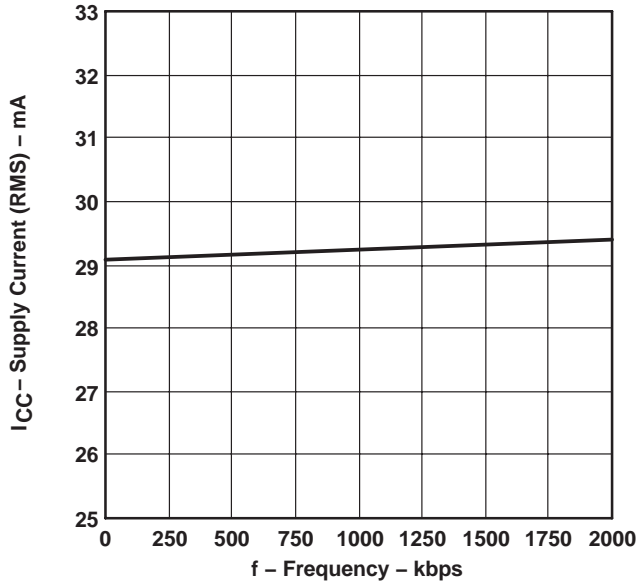

Figure 9

LOGIC INPUT CURRENT (D PIN)
vs
INPUT VOLTAGE

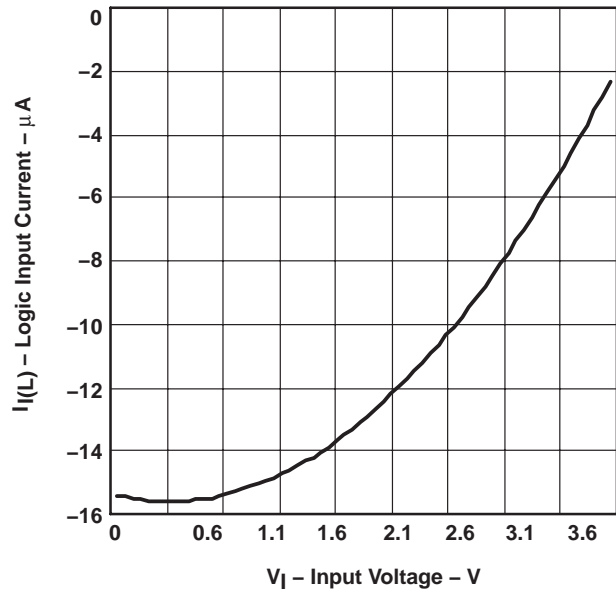

Figure 10

BUS INPUT CURRENT
vs
BUS INPUT VOLTAGE

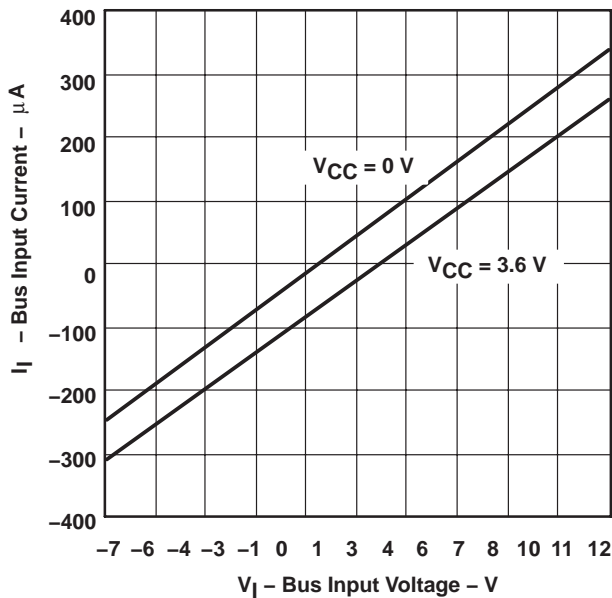

Figure 11

DRIVER LOW-LEVEL OUTPUT CURRENT
vs
LOW-LEVEL OUTPUT VOLTAGE

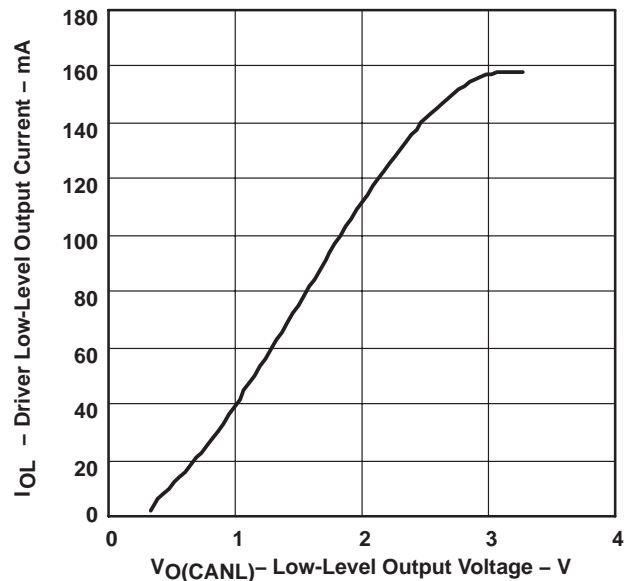

Figure 12

TYPICAL CHARACTERISTICS

DRIVER HIGH-LEVEL OUTPUT CURRENT
vs
HIGH-LEVEL OUTPUT VOLTAGE

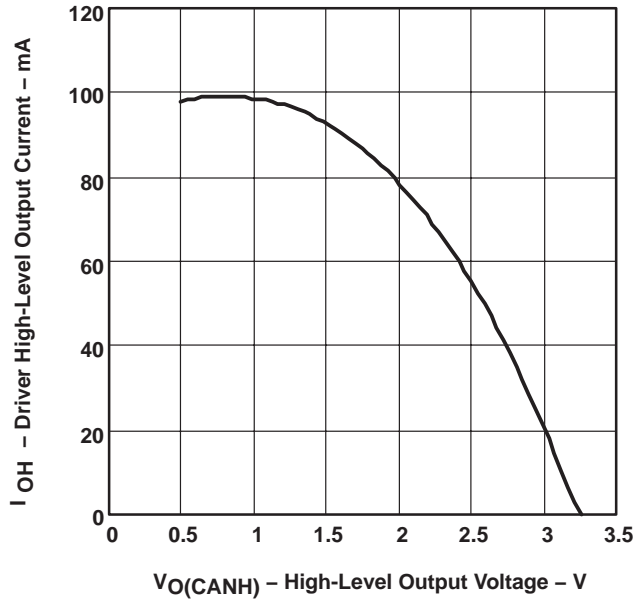

Figure 13

DOMINANT VOLTAGE (VOD)
vs
FREE-AIR TEMPERATURE

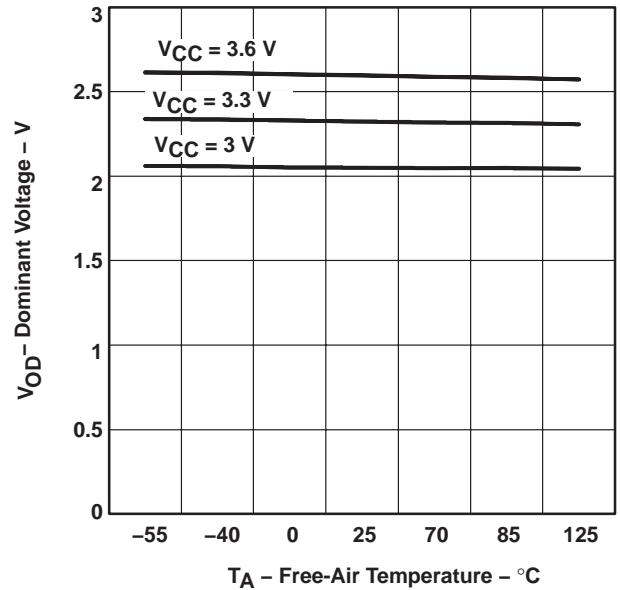

Figure 14

RECEIVER LOW-TO-HIGH PROPAGATION DELAY TIME
vs
FREE-AIR TEMPERATURE

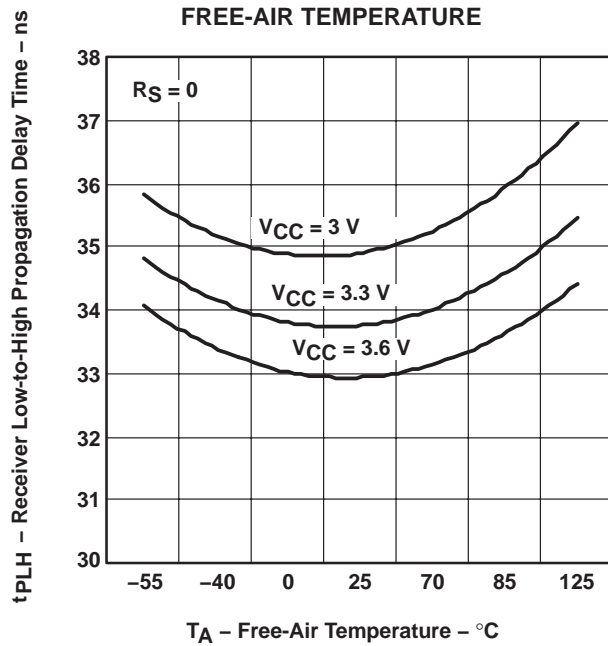

Figure 15

RECEIVER HIGH-TO-LOW PROPAGATION DELAY TIME
vs
FREE-AIR TEMPERATURE

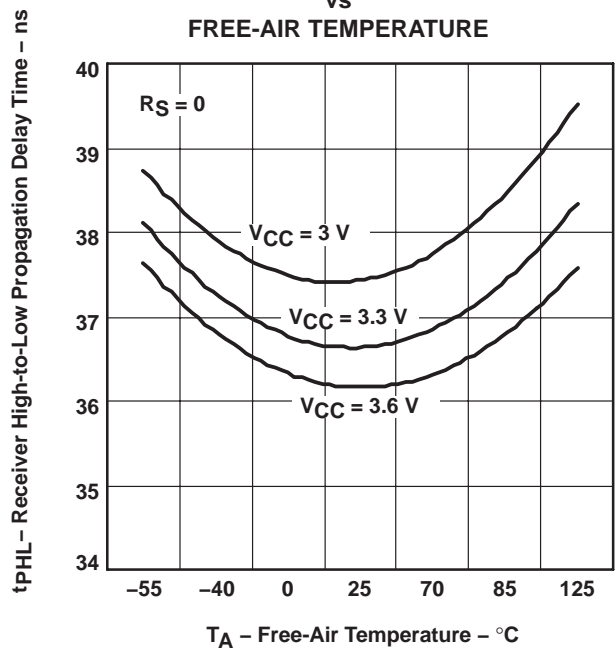

Figure 16

TYPICAL CHARACTERISTICS

DRIVER LOW-TO-HIGH PROPAGATION DELAY TIME
vs
FREE-AIR TEMPERATURE

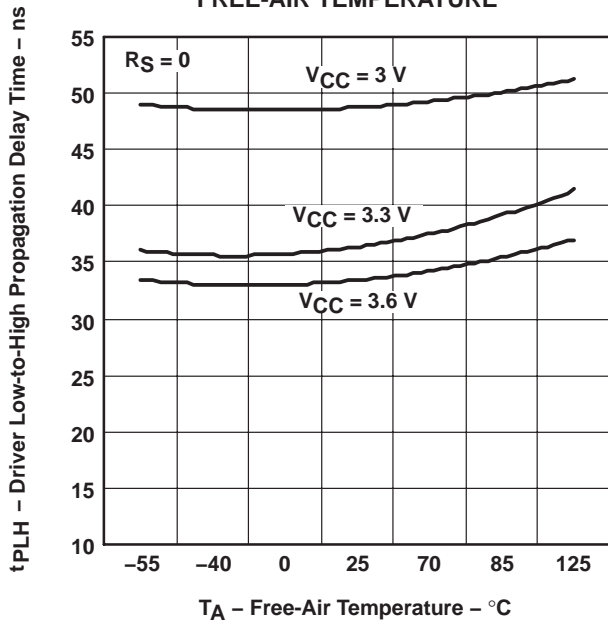

Figure 17

DRIVER HIGH-TO-LOW PROPAGATION DELAY TIME
vs
FREE-AIR TEMPERATURE

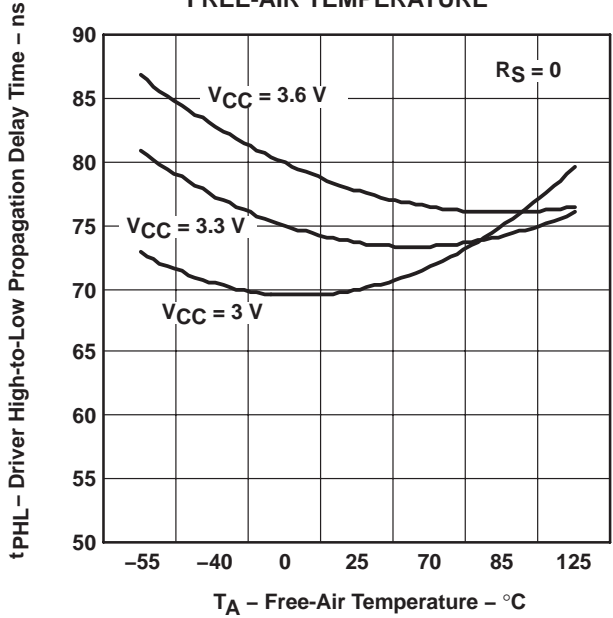

Figure 18

DRIVER LOW-TO-HIGH PROPAGATION DELAY TIME
vs
FREE-AIR TEMPERATURE

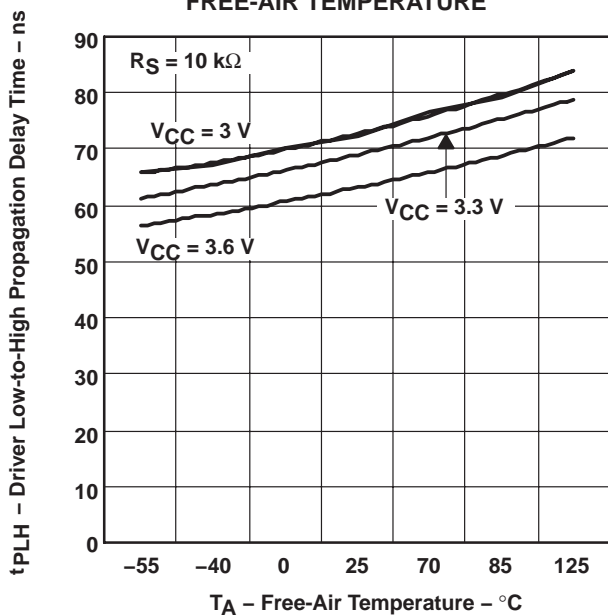

Figure 19

DRIVER HIGH-TO-LOW PROPAGATION DELAY TIME
vs
FREE-AIR TEMPERATURE

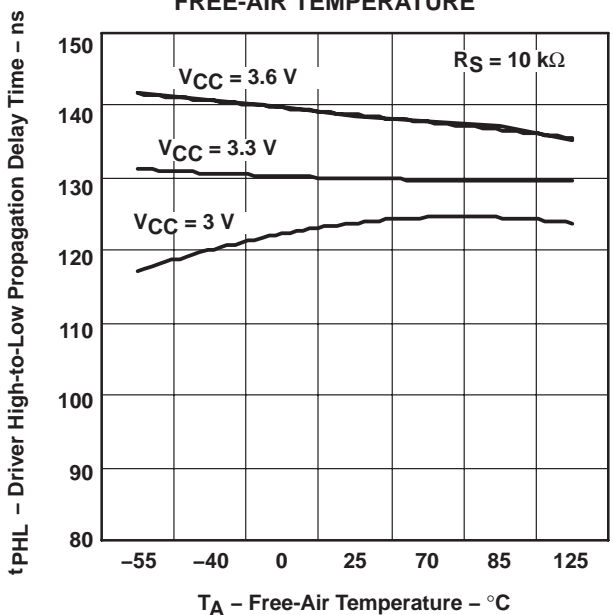

Figure 20

TYPICAL CHARACTERISTICS

DRIVER LOW-TO-HIGH PROPAGATION DELAY TIME
vs
FREE-AIR TEMPERATURE

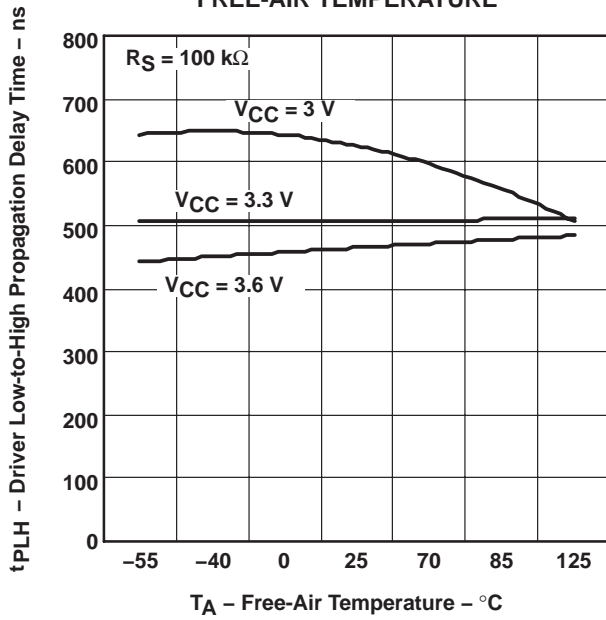

Figure 21

DRIVER HIGH-TO-LOW PROPAGATION DELAY TIME
vs
FREE-AIR TEMPERATURE

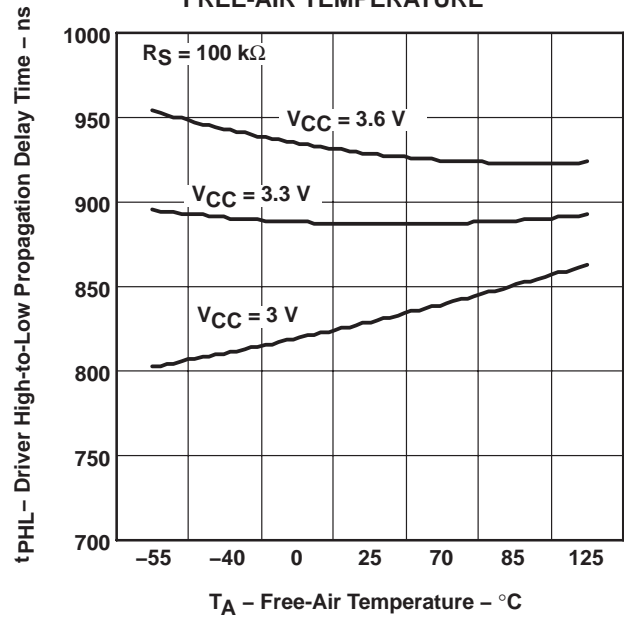

Figure 22

DRIVER OUTPUT CURRENT
vs
SUPPLY VOLTAGE

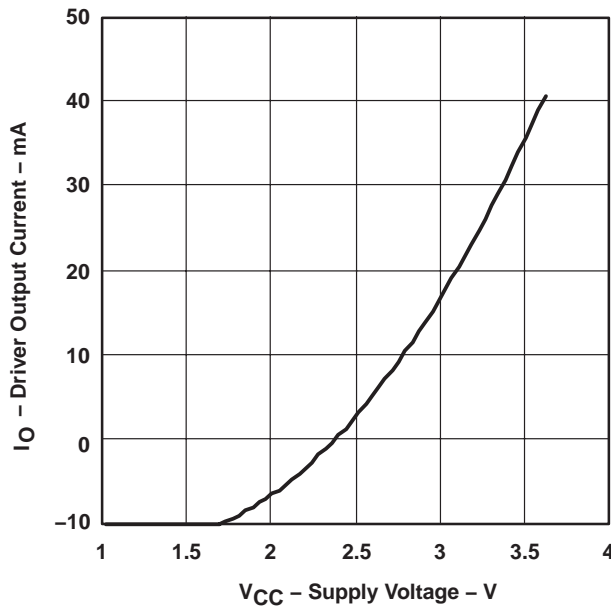

Figure 23

DIFFERENTIAL DRIVER OUTPUT FALL TIME
vs Source Resistance (R_S)

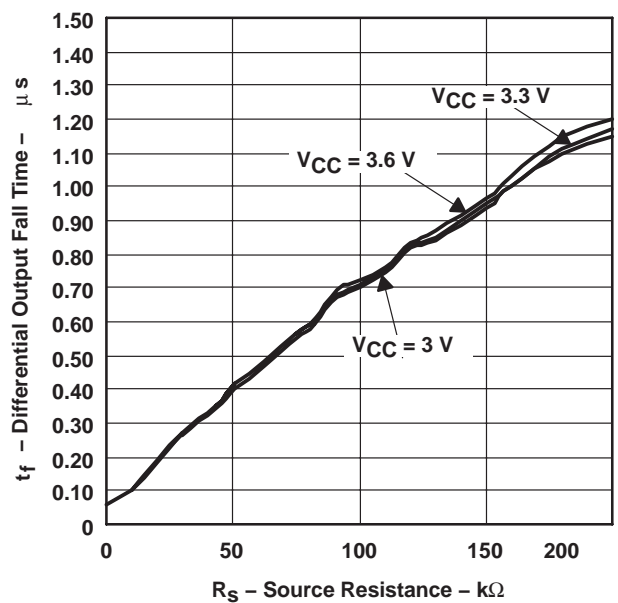

Figure 24

TYPICAL CHARACTERISTICS

REFERENCE VOLTAGE
vs
REFERENCE CURRENT

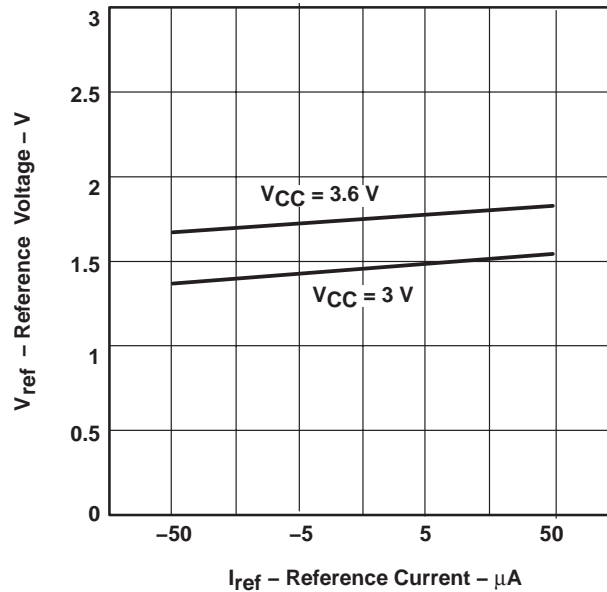

Figure 25

APPLICATION INFORMATION

This application provides information concerning the implementation of the physical medium attachment layer in a CAN network according to the ISO 11898 standard. It presents a typical application circuit and test results, as well as discussions on slope control, total loop delay, and interoperability in 5-V systems.

introduction

ISO 11898 is the international standard for high-speed serial communication using the controller area network (CAN) bus protocol. It supports multimaster operation, real-time control, programmable data rates up to 1 Mbps, and powerful redundant error checking procedures that provide reliable data transmission. It is suited for networking *intelligent* devices as well as sensors and actuators within the rugged electrical environment of a machine chassis or factory floor. The SN65HVD230M family of 3.3-V CAN transceivers implement the lowest layers of the ISO/OSI reference model. This is the interface with the physical signaling output of the CAN controller of the Texas Instruments TMS320Lx240x 3.3-V DSPs, as illustrated in Figure 26.

APPLICATION INFORMATION

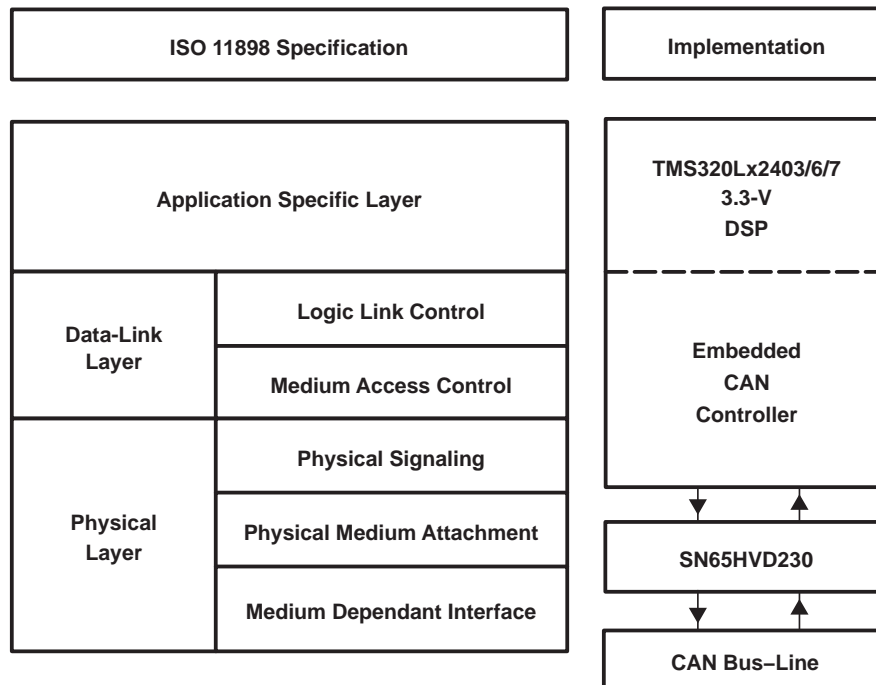

Figure 26. The Layered ISO 11898 Standard Architecture

The SN65HVD230M family of CAN transceivers are compatible with the ISO 11898 standard; this ensures interoperability with other standard-compliant products.

application of the SN65HVD230M

Figure 27 illustrates a typical application of the SN65HVD230M family. The output of a DSP's CAN controller is connected to the serial driver input, pin D, and receiver serial output, pin R, of the transceiver. The transceiver is then attached to the differential bus lines at pins CANH and CANL. Typically, the bus is a twisted pair of wires with a characteristic impedance of 120 Ω, in the standard half-duplex multipoint topology of Figure 28. Each end of the bus is terminated with 120-Ω resistors in compliance with the standard to minimize signal reflections on the bus.

APPLICATION INFORMATION

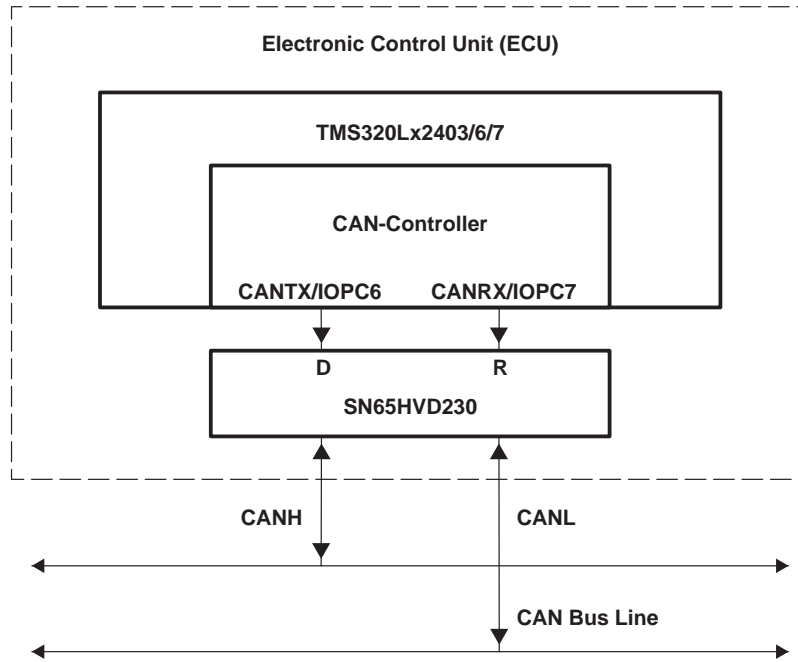

Figure 27. Details of a Typical CAN Node

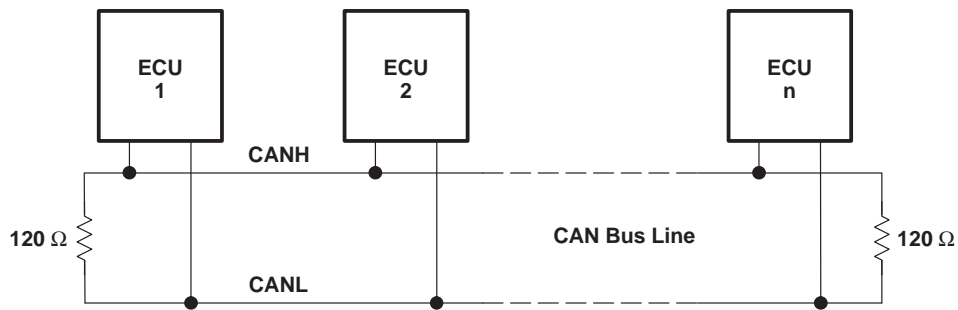

Figure 28. Typical CAN Network

The SN65HVD230M 3.3-V CAN transceivers provide the interface between the 3.3-V TMS320Lx2403/6/7 CAN DSPs and the differential bus line, and are designed to transmit data at signaling rates up to 1 Mbps as defined by the ISO 11898 standard.

features of the SN65HVD230M

These transceivers feature 3.3-V operation and standard compatibility with signaling rates up to 1 Mbps, and also offer 16-kV HBM ESD protection on the bus pins, thermal shutdown protection, bus fault protection, and open-circuit receiver failsafe. The failsafe design of the receiver assures a logic high at the receiver output if the bus wires become open circuited. If a high ambient operating environment temperature or excessive output current result in thermal shutdown, the bus pins become high impedance, while the D and R pins default to a logic high.

APPLICATION INFORMATION

features of the SN65HVD230M (continued)

The bus pins are also maintained in a high-impedance state during low V_{CC} conditions to ensure glitch-free power-up and power-down bus protection for hot-plugging applications. This high-impedance condition also means that an unpowered node will not disturb the bus. Transceivers without this feature usually have a low output impedance. This results in a high current demand when the transceiver is unpowered, a condition that could affect the entire bus.

operating modes

R_S (pin 8) of the SN65HVD230M provides for three different modes of operation: high-speed mode, slope-control mode, and low-power standby mode.

high-speed mode

The high-speed mode can be selected by applying a logic low to R_S (pin 8). The high-speed mode of operation is commonly employed in industrial applications. High-speed allows the output to switch as fast as possible with no internal limitation on the output rise and fall slopes. The only limitations of the high-speed operation are cable length and radiated emission concerns, each of which is addressed by the slope control mode of operation.

If the low-power standby mode is to be employed in the circuit, direct connection to a DSP output pin can be used to switch between a logic-low level ($< 1\text{ V}$) for high speed mode operation, and the logic-high level ($> 0.75\text{ V}_{CC}$) for standby mode operation. Figure 29 shows a typical DSP connection and Figure 30 shows the SN65HVD230M driver output signal in high-speed mode on the CAN bus.

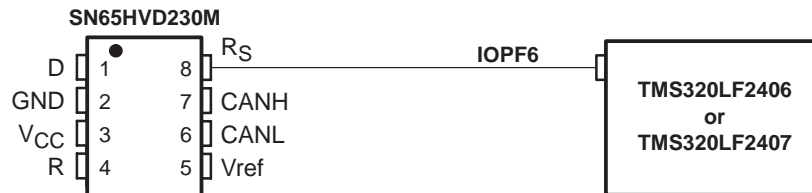

Figure 29. R_S (Pin 8) Connection to a TMS320LF2406/07 for High-Speed or Standby Mode Operation

APPLICATION INFORMATION

high-speed mode (continued)

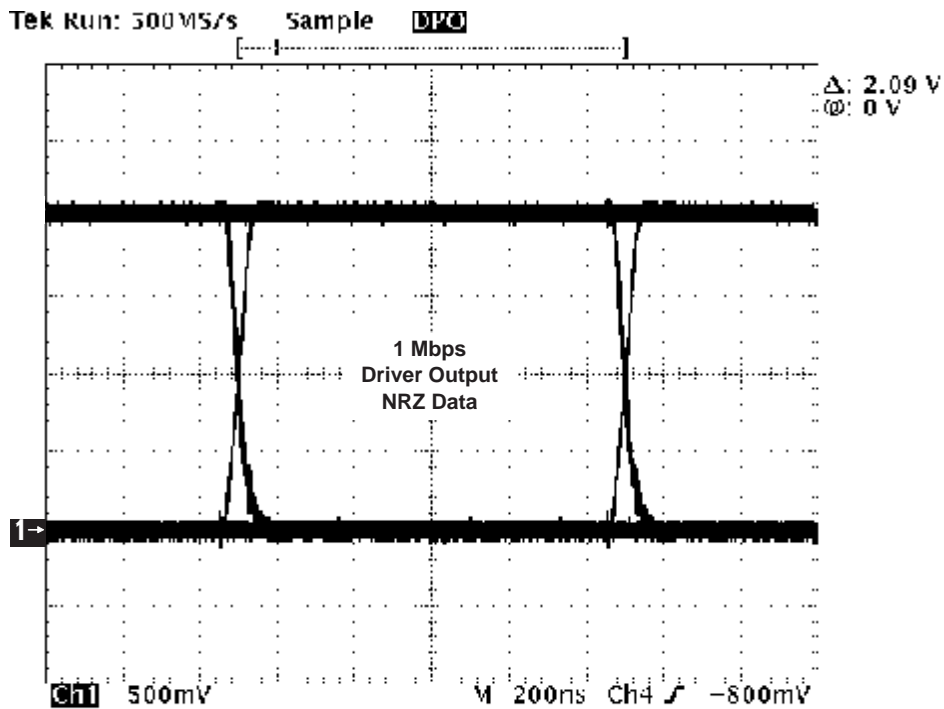

Figure 30. Typical SN65HVD230M High-Speed Mode Output Waveform Into a 60-Ω Load

slope-control mode

Electromagnetic compatibility is essential in many applications using unshielded bus cable to reduce system cost. To reduce the electromagnetic interference generated by fast rise times and resulting harmonics, the rise and fall slopes of the SN65HVD230M driver outputs can be adjusted by connecting a resistor from R_S (pin 8) to ground or to a logic low voltage, as shown in Figure 31. The slope of the driver output signal is proportional to the pin's output current. This slope control is implemented with an external resistor value of 10 kΩ to achieve a ≈ 15 V/μs slew rate, and up to 100 kΩ to achieve a ≈ 2 V/μs slew rate as displayed in Figure 32. Typical driver output waveforms from a pulse input signal with and without slope control are displayed in Figure 33. A pulse input is used rather than NRZ data to clearly display the actual slew rate.

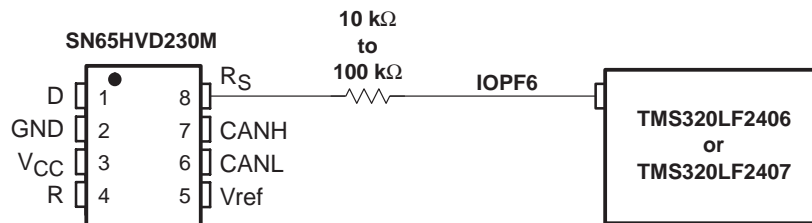

Figure 31. Slope-Control or Standby Mode Connection to a DSP

APPLICATION INFORMATION

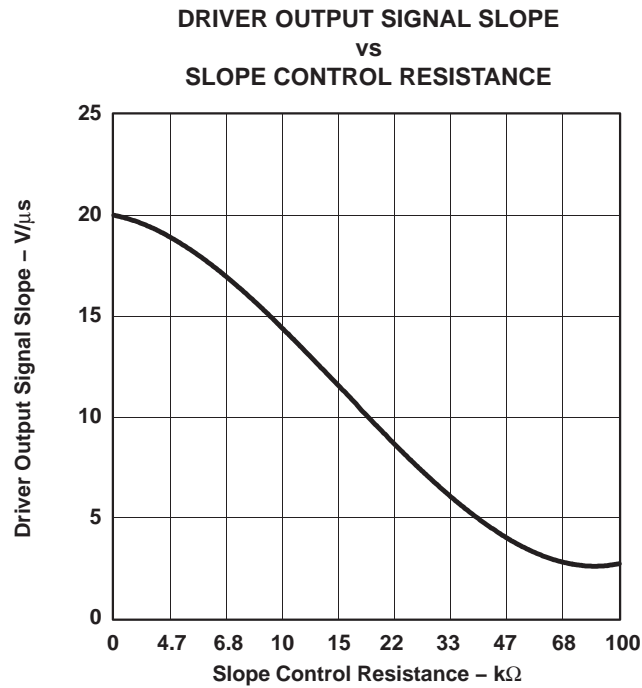

Figure 32. SN65HVD230M Driver Output Signal Slope vs Slope Control Resistance Value

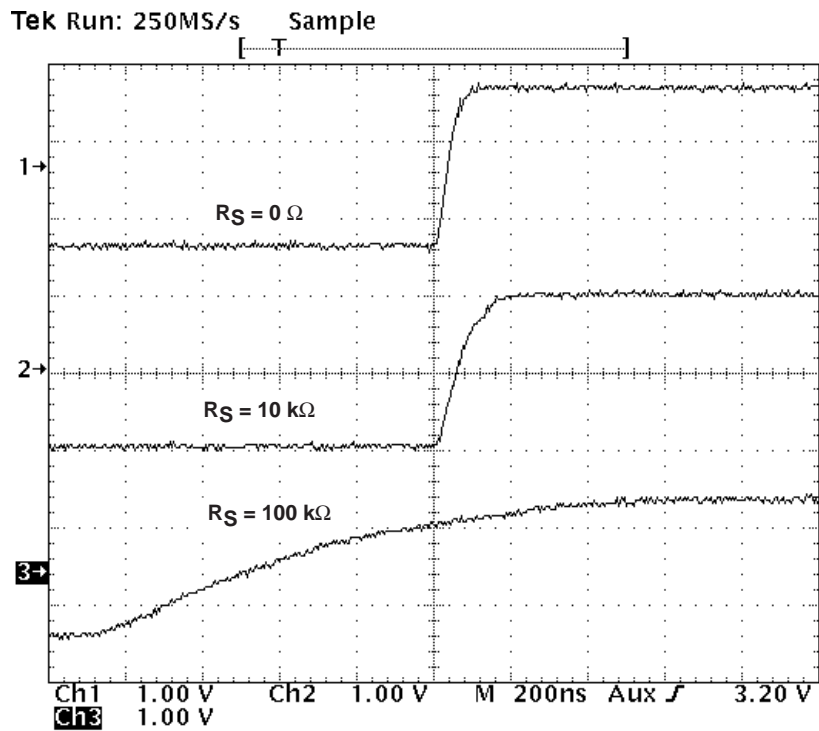

Figure 33. Typical SN65HVD230M 250-kbps Output Pulse Waveforms With Slope Control

APPLICATION INFORMATION

standby mode (listen only mode) of the SN65HVD230M

If a logic high ($> 0.75 V_{CC}$) is applied to R_S (pin 8) in Figure 29 and Figure 31, the circuit of the SN65HVD230M enters a low-current, *listen only* standby mode during which the driver is switched off and the receiver remains active. In this *listen only* state, the transceiver is completely passive to the bus. It makes no difference if a slope control resistor is in place as shown in Figure 31. The DSP can reverse this low-power standby mode when the rising edge of a dominant state (bus differential voltage > 900 mV typical) occurs on the bus. The DSP, sensing bus activity, reactivates the driver circuit by placing a logic low (< 1.2 V) on R_S (pin 8).

loop propagation delay

Transceiver loop delay is a measure of the overall device propagation delay, consisting of the delay from the driver input to the differential outputs, plus the delay from the receiver inputs to its output.

The loop delay of the transceiver displayed in Figure 34 increases accordingly when slope control is being used. This increased loop delay means that the total bus length must be reduced to meet the CAN bit-timing requirements of the overall system. The loop delay becomes ≈ 100 ns when employing slope control with a 10-k Ω resistor, and ≈ 500 ns with a 100-k Ω resistor. Therefore, considering that the rule-of-thumb propagation delay of typical bus cable is 5 ns/m, slope control with the 100-k Ω resistor decreases the allowable bus length by the difference between the 500-ns max loop delay and the loop delay with no slope control, 70.7 ns. This equates to $(500 - 70.7 \text{ ns}) / 5 \text{ ns}$, or approximately 86 m less bus length. This slew-rate/bus length trade-off to reduce electromagnetic interference to adjoining circuits from the bus can also be solved with a high-quality shielded bus cable.

APPLICATION INFORMATION

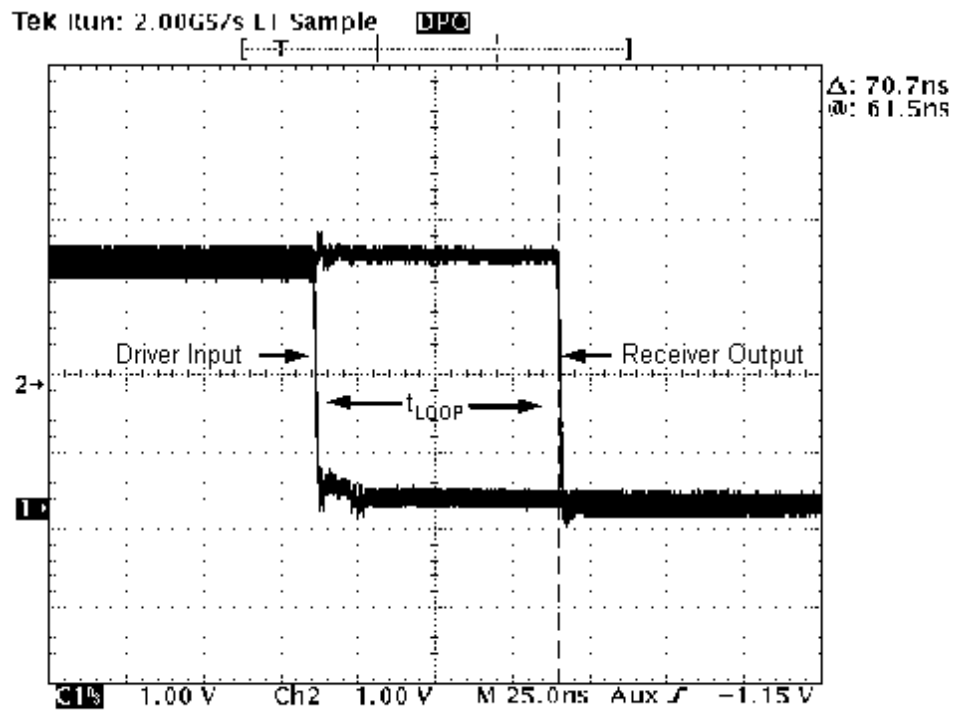

Figure 34. 70.7-ns Loop Delay Through the SN65HVD230M With $R_S = 0$

APPLICATION INFORMATION

interoperability with 5-V CAN systems

It is essential that the 3.3-V SN65HVD230M family performs seamlessly with 5-V transceivers because of the large number of 5-V devices installed. Figure 35 displays a test bus of a 3.3-V node with the SN65HVD230M, and three 5-V nodes: one for each of TI's SN65LBC031 and UC5350 transceivers, and one using a competitor X250 transceiver.

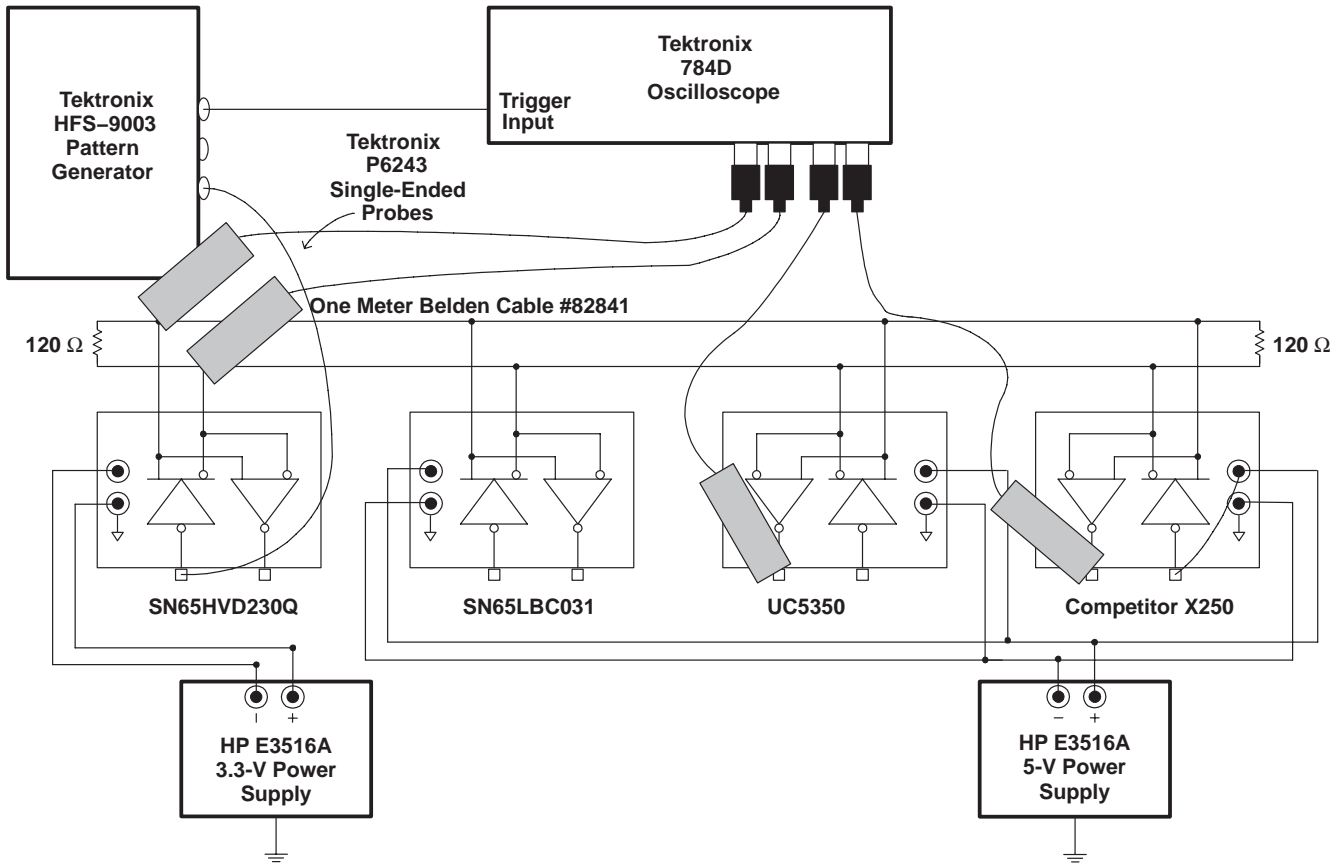

Figure 35. 3.3-V/5-V CAN Transceiver Test Bed

APPLICATION INFORMATION

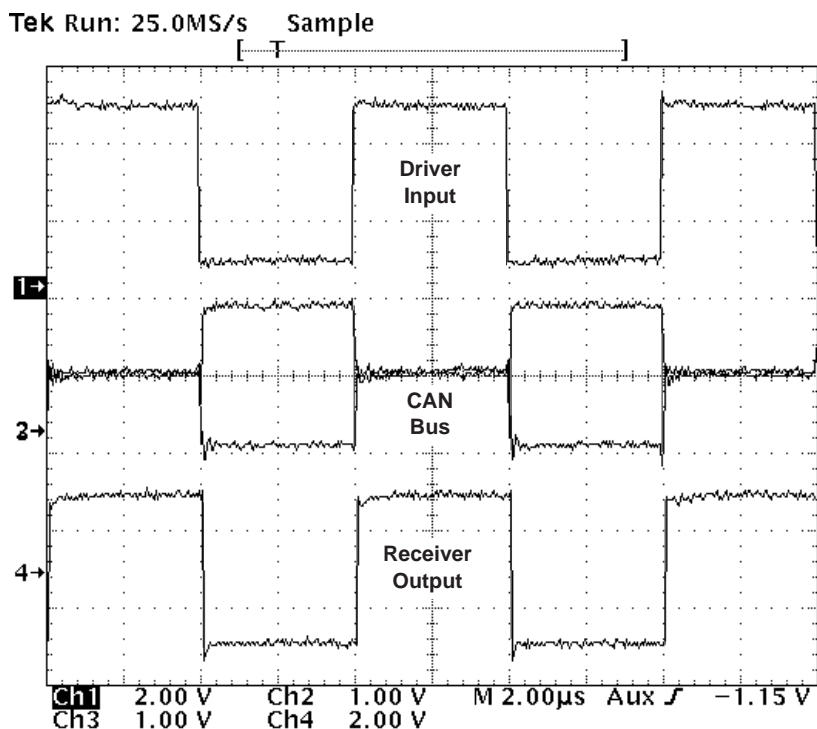

Figure 36. SN65HVD230M's Input, CAN Bus, and X250's RXD Output Waveforms

Figure 36 displays the SN65HVD230M's input signal, the CAN bus, and the competitor X250's receiver output waveforms. The input waveform from the Tektronix HFS-9003 Pattern Generator in Figure 35 to the SN65HVD230M is a 250-kbps pulse for this test. The circuit is monitored with Tektronix P6243, 1-GHz single-ended probes in order to display the CAN dominant and recessive bus states.

Figure 36 displays the 250-kbps pulse input waveform to the SN65HVD230M on channel 1. Channels 2 and 3 display CANH and CANL respectively, with their recessive bus states overlaying each other to clearly display the dominant and recessive CAN bus states. Channel 4 is the receiver output waveform of the competitor X250.

PACKAGING INFORMATION

Orderable Device	Status (1)	Package Type	Package Drawing	Pins	Package Qty	Eco Plan (2)	Lead/Ball Finish (6)	MSL Peak Temp (3)	Op Temp (°C)	Device Marking (4/5)	Samples
SN65HVD230MDREP	ACTIVE	SOIC	D	8	2500	Green (RoHS & no Sb/Br)	CU NIPDAU	Level-1-260C-UNLIM	-55 to 125	H230EP	Samples
V62/06629-01XE	ACTIVE	SOIC	D	8	2500	Green (RoHS & no Sb/Br)	CU NIPDAU	Level-1-260C-UNLIM	-55 to 125	H230EP	Samples

(1) The marketing status values are defined as follows:

ACTIVE: Product device recommended for new designs.

LIFEBUY: TI has announced that the device will be discontinued, and a lifetime-buy period is in effect.

NRND: Not recommended for new designs. Device is in production to support existing customers, but TI does not recommend using this part in a new design.

PREVIEW: Device has been announced but is not in production. Samples may or may not be available.

OBSOLETE: TI has discontinued the production of the device.

(2) Eco Plan - The planned eco-friendly classification: Pb-Free (RoHS), Pb-Free (RoHS Exempt), or Green (RoHS & no Sb/Br) - please check <http://www.ti.com/productcontent> for the latest availability information and additional product content details.

TBD: The Pb-Free/Green conversion plan has not been defined.

Pb-Free (RoHS): TI's terms "Lead-Free" or "Pb-Free" mean semiconductor products that are compatible with the current RoHS requirements for all 6 substances, including the requirement that lead not exceed 0.1% by weight in homogeneous materials. Where designed to be soldered at high temperatures, TI Pb-Free products are suitable for use in specified lead-free processes.

Pb-Free (RoHS Exempt): This component has a RoHS exemption for either 1) lead-based flip-chip solder bumps used between the die and package, or 2) lead-based die adhesive used between the die and leadframe. The component is otherwise considered Pb-Free (RoHS compatible) as defined above.

Green (RoHS & no Sb/Br): TI defines "Green" to mean Pb-Free (RoHS compatible), and free of Bromine (Br) and Antimony (Sb) based flame retardants (Br or Sb do not exceed 0.1% by weight in homogeneous material)

(3) MSL, Peak Temp. - The Moisture Sensitivity Level rating according to the JEDEC industry standard classifications, and peak solder temperature.

(4) There may be additional marking, which relates to the logo, the lot trace code information, or the environmental category on the device.

(5) Multiple Device Markings will be inside parentheses. Only one Device Marking contained in parentheses and separated by a "~" will appear on a device. If a line is indented then it is a continuation of the previous line and the two combined represent the entire Device Marking for that device.

(6) Lead/Ball Finish - Orderable Devices may have multiple material finish options. Finish options are separated by a vertical ruled line. Lead/Ball Finish values may wrap to two lines if the finish value exceeds the maximum column width.

Important Information and Disclaimer: The information provided on this page represents TI's knowledge and belief as of the date that it is provided. TI bases its knowledge and belief on information provided by third parties, and makes no representation or warranty as to the accuracy of such information. Efforts are underway to better integrate information from third parties. TI has taken and continues to take reasonable steps to provide representative and accurate information but may not have conducted destructive testing or chemical analysis on incoming materials and chemicals. TI and TI suppliers consider certain information to be proprietary, and thus CAS numbers and other limited information may not be available for release.

In no event shall TI's liability arising out of such information exceed the total purchase price of the TI part(s) at issue in this document sold by TI to Customer on an annual basis.

TAPE AND REEL INFORMATION



QUADRANT ASSIGNMENTS FOR PIN 1 ORIENTATION IN TAPE



*All dimensions are nominal

Device	Package Type	Package Drawing	Pins	SPQ	Reel Diameter (mm)	Reel Width W1 (mm)	A0 (mm)	B0 (mm)	K0 (mm)	P1 (mm)	W (mm)	Pin1 Quadrant
SN65HVD230MDREP	SOIC	D	8	2500	330.0	12.4	6.4	5.2	2.1	8.0	12.0	Q1

TAPE AND REEL BOX DIMENSIONS



*All dimensions are nominal

Device	Package Type	Package Drawing	Pins	SPQ	Length (mm)	Width (mm)	Height (mm)
SN65HVD230MDREP	SOIC	D	8	2500	367.0	367.0	35.0

D (R-PDSO-G8)

PLASTIC SMALL OUTLINE

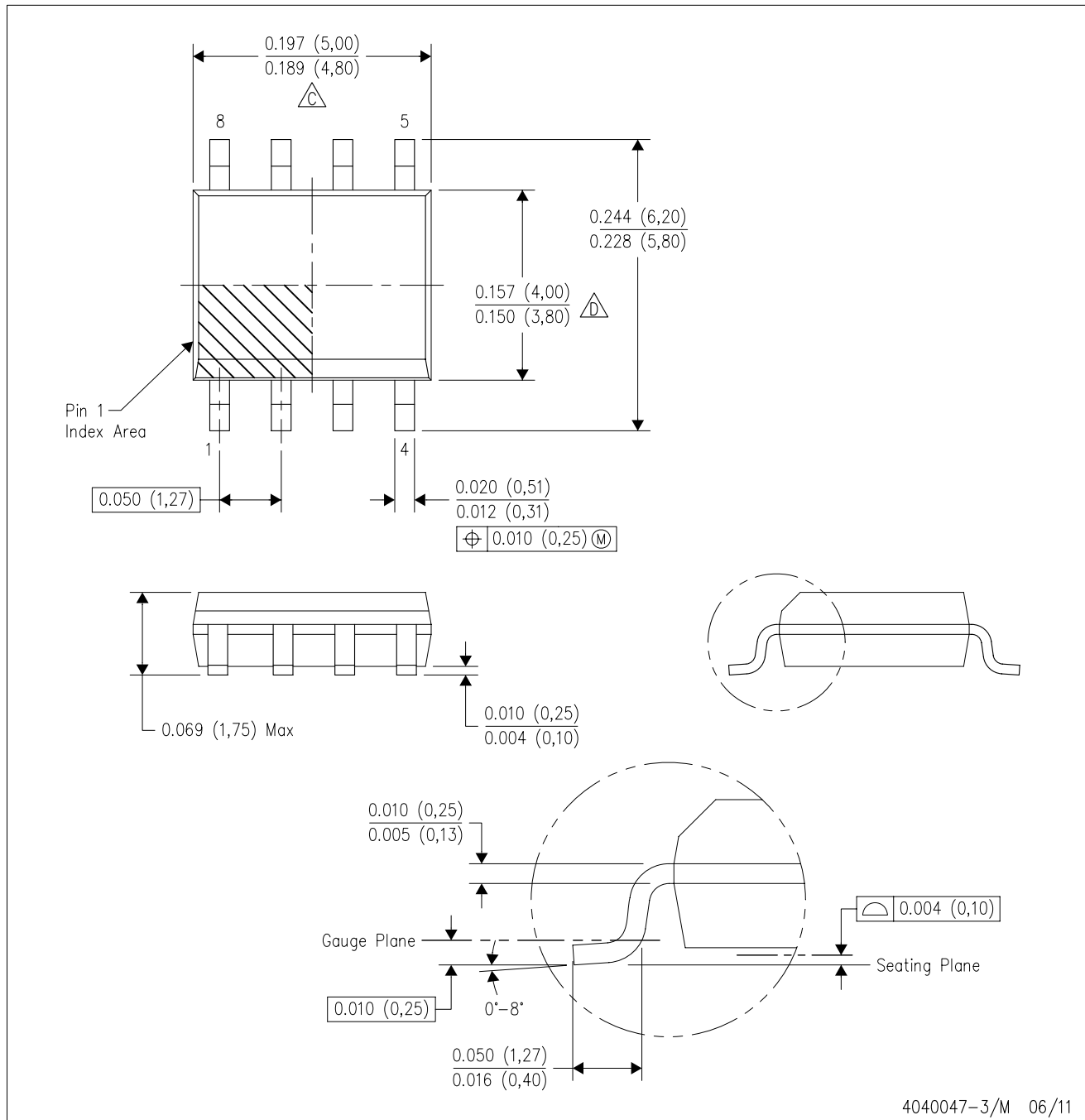

- NOTES:
- A. All linear dimensions are in inches (millimeters).
 - B. This drawing is subject to change without notice.
 - Body length does not include mold flash, protrusions, or gate burrs. Mold flash, protrusions, or gate burrs shall not exceed 0.006 (0,15) each side.
 - Body width does not include interlead flash. Interlead flash shall not exceed 0.017 (0,43) each side.
 - E. Reference JEDEC MS-012 variation AA.

D (R-PDSO-G8)

PLASTIC SMALL OUTLINE



4211283-2/E 08/12

- NOTES:
- A. All linear dimensions are in millimeters.
 - B. This drawing is subject to change without notice.
 - C. Publication IPC-7351 is recommended for alternate designs.
 - D. Laser cutting apertures with trapezoidal walls and also rounding corners will offer better paste release. Customers should contact their board assembly site for stencil design recommendations. Refer to IPC-7525 for other stencil recommendations.
 - E. Customers should contact their board fabrication site for solder mask tolerances between and around signal pads.

IMPORTANT NOTICE

Texas Instruments Incorporated and its subsidiaries (TI) reserve the right to make corrections, enhancements, improvements and other changes to its semiconductor products and services per JESD46, latest issue, and to discontinue any product or service per JESD48, latest issue. Buyers should obtain the latest relevant information before placing orders and should verify that such information is current and complete. All semiconductor products (also referred to herein as "components") are sold subject to TI's terms and conditions of sale supplied at the time of order acknowledgment.

TI warrants performance of its components to the specifications applicable at the time of sale, in accordance with the warranty in TI's terms and conditions of sale of semiconductor products. Testing and other quality control techniques are used to the extent TI deems necessary to support this warranty. Except where mandated by applicable law, testing of all parameters of each component is not necessarily performed.

TI assumes no liability for applications assistance or the design of Buyers' products. Buyers are responsible for their products and applications using TI components. To minimize the risks associated with Buyers' products and applications, Buyers should provide adequate design and operating safeguards.

TI does not warrant or represent that any license, either express or implied, is granted under any patent right, copyright, mask work right, or other intellectual property right relating to any combination, machine, or process in which TI components or services are used. Information published by TI regarding third-party products or services does not constitute a license to use such products or services or a warranty or endorsement thereof. Use of such information may require a license from a third party under the patents or other intellectual property of the third party, or a license from TI under the patents or other intellectual property of TI.

Reproduction of significant portions of TI information in TI data books or data sheets is permissible only if reproduction is without alteration and is accompanied by all associated warranties, conditions, limitations, and notices. TI is not responsible or liable for such altered documentation. Information of third parties may be subject to additional restrictions.

Resale of TI components or services with statements different from or beyond the parameters stated by TI for that component or service voids all express and any implied warranties for the associated TI component or service and is an unfair and deceptive business practice. TI is not responsible or liable for any such statements.

Buyer acknowledges and agrees that it is solely responsible for compliance with all legal, regulatory and safety-related requirements concerning its products, and any use of TI components in its applications, notwithstanding any applications-related information or support that may be provided by TI. Buyer represents and agrees that it has all the necessary expertise to create and implement safeguards which anticipate dangerous consequences of failures, monitor failures and their consequences, lessen the likelihood of failures that might cause harm and take appropriate remedial actions. Buyer will fully indemnify TI and its representatives against any damages arising out of the use of any TI components in safety-critical applications.

In some cases, TI components may be promoted specifically to facilitate safety-related applications. With such components, TI's goal is to help enable customers to design and create their own end-product solutions that meet applicable functional safety standards and requirements. Nonetheless, such components are subject to these terms.

No TI components are authorized for use in FDA Class III (or similar life-critical medical equipment) unless authorized officers of the parties have executed a special agreement specifically governing such use.

Only those TI components which TI has specifically designated as military grade or "enhanced plastic" are designed and intended for use in military/aerospace applications or environments. Buyer acknowledges and agrees that any military or aerospace use of TI components which have **not** been so designated is solely at the Buyer's risk, and that Buyer is solely responsible for compliance with all legal and regulatory requirements in connection with such use.

TI has specifically designated certain components as meeting ISO/TS16949 requirements, mainly for automotive use. In any case of use of non-designated products, TI will not be responsible for any failure to meet ISO/TS16949.

Products

Audio	www.ti.com/audio
Amplifiers	amplifier.ti.com
Data Converters	dataconverter.ti.com
DLP® Products	www.dlp.com
DSP	dsp.ti.com
Clocks and Timers	www.ti.com/clocks
Interface	interface.ti.com
Logic	logic.ti.com
Power Mgmt	power.ti.com
Microcontrollers	microcontroller.ti.com
RFID	www.ti-rfid.com
OMAP Applications Processors	www.ti.com/omap
Wireless Connectivity	www.ti.com/wirelessconnectivity

Applications

Automotive and Transportation	www.ti.com/automotive
Communications and Telecom	www.ti.com/communications
Computers and Peripherals	www.ti.com/computers
Consumer Electronics	www.ti.com/consumer-apps
Energy and Lighting	www.ti.com/energy
Industrial	www.ti.com/industrial
Medical	www.ti.com/medical
Security	www.ti.com/security
Space, Avionics and Defense	www.ti.com/space-avionics-defense
Video and Imaging	www.ti.com/video

TI E2E Community

e2e.ti.com