

SN65HVD3x-EP 3.3-V Full-Duplex RS-485 Drivers And Receivers

1 Features

- 1/8 Unit-Load Option Available (up to 256 Nodes on the Bus)
- Bus-Pin ESD Protection Exceeds 15 kV HBM
- Optional Driver Output Transition Times for Signaling Rates ⁽¹⁾ of 1 Mbps, 5 Mbps, and 25 Mbps
- Low-Current Standby Mode: <math><1 \mu\text{A}</math>
- Glitch-Free Power-Up and Power-Down Protection for Hot-Plugging Applications
- 5-V Tolerant Inputs
- Bus Idle, Open, and Short-Circuit Fail Safe
- Driver Current Limiting and Thermal Shutdown
- Meet or Exceed the Requirements of ANSI TIA/EIA-485-A and RS-422 Compatible

2 Applications

- Utility Meters
- DTE and DCE Interfaces
- Industrial, Process, and Building Automation
- Point-of-Sale (POS) Terminals and Networks
- Controlled Baseline
- One Assembly and Test Site
- One Fabrication Site
- Available in Military ($-55^{\circ}\text{C}/125^{\circ}\text{C}$) Temperature Range
- Extended Product Life Cycle
- Extended Product-Change Notification
- Product Traceability

- (1) The signaling rate of a line is the number of voltage transitions that are made per second expressed in the units bps (bits per second).

3 Description

The SN65HVD3x-EP devices are 3-state differential line drivers and differential-input line receivers that operate with 3-V power supply.

Each driver and receiver has separate input and output pins for full-duplex bus communication designs. They are designed for balanced transmission lines and interoperability with ANSI TIA/EIA-485A, TIA/EIA-422-B, ITU-T v.11, and ISO 8482:1993 standard-compliant devices.

The SN65HVD30, SN65HVD31, and SN65HVD32 are fully enabled with no external enabling pins.

The SN65HVD33, SN65HVD34, and SN65HVD35 have active-high driver enables and active-low receiver enables. A low (less than $1 \mu\text{A}$) standby current can be achieved by disabling both the driver and receiver.

All devices are characterized for operation from -55°C to 125°C .

Device Information⁽¹⁾

PART NUMBER	PACKAGE	BODY SIZE (NOM)
SN65HVD3x-EP	SOIC (8)	4.90 mm x 3.91 mm
	SOIC (14)	8.65 mm x 3.91 mm

- (1) For all available packages, see the orderable addendum at the end of the datasheet.

Typical Application Schematic

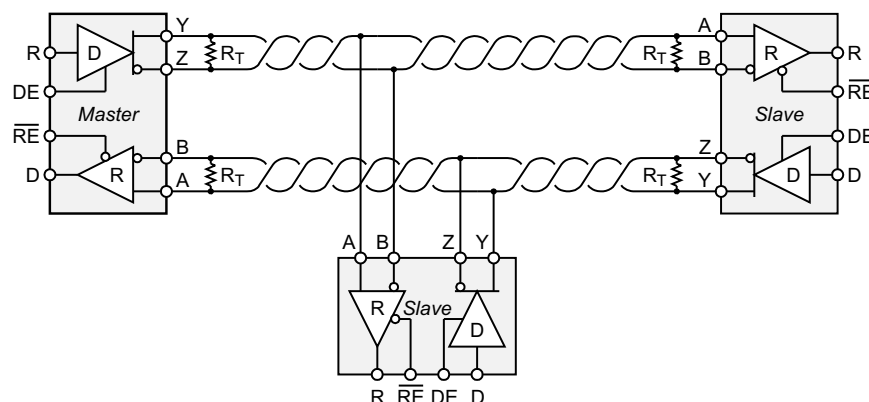

Table of Contents

1 Features	1	9 Detailed Description	17
2 Applications	1	9.1 Overview	17
3 Description	1	9.2 Functional Block Diagram	17
4 Revision History	2	9.3 Feature Description	17
5 Device Comparison	3	9.4 Device Functional Modes	21
6 Pin Configuration and Functions	4	10 Application and Implementation	23
7 Specifications	5	10.1 Application Information	23
7.1 Absolute Maximum Ratings	5	10.2 Typical Application	23
7.2 ESD Ratings	5	11 Power Supply Recommendations	27
7.3 Recommended Operating Conditions	6	12 Layout	27
7.4 Thermal Information	6	12.1 Layout Guidelines	27
7.5 Electrical Characteristics: Driver	7	12.2 Layout Example	27
7.6 Electrical Characteristics: Receiver	8	13 Device and Documentation Support	28
7.7 Switching Characteristics: Driver	9	13.1 Related Links	28
7.8 Switching Characteristics: Receiver	10	13.2 Community Resources	28
7.9 Receiver Equalization Characteristics	10	13.3 Trademarks	28
7.10 Dissipation Ratings	10	13.4 Electrostatic Discharge Caution	28
7.11 Typical Characteristics	11	13.5 Glossary	28
8 Parameter Measurement Information	13	14 Mechanical, Packaging, and Orderable Information	28

4 Revision History

NOTE: Page numbers for previous revisions may differ from page numbers in the current version.

Changes from Revision D (March 2012) to Revision E

Page

<ul style="list-style-type: none"> Added <i>Handling Rating</i> table, <i>Feature Description</i> section, <i>Device Functional Modes</i>, <i>Application and Implementation</i> section, <i>Power Supply Recommendations</i> section, <i>Layout</i> section, <i>Device and Documentation Support</i> section, and <i>Mechanical, Packaging, and Orderable Information</i> section 	1
---	----------

5 Device Comparison⁽¹⁾

Table 1. Available Options

BASE PART NUMBER	SIGNALING RATE	UNIT LOADS	RECEIVER EQUALIZATION	ENABLES	SOIC MARKING
SN65HVD30MDREP	25 Mbps	1/2	No	No	HVD30EP
SN65HVD31MDREP ⁽¹⁾	5 Mbps	1/8	No	No	PREVIEW
SN65HVD32MDREP ⁽¹⁾	1 Mbps	1/8	No	No	PREVIEW
SN65HVD33MDREP	25 Mbps	1/2	No	Yes	HVD33EP
SN65HVD34MDREP ⁽¹⁾	5 Mbps	1/8	No	Yes	PREVIEW
SN65HVD35MDREP ⁽¹⁾	1 Mbps	1/8	No	Yes	PREVIEW

(1) For the most current package and ordering information, see the Package Option Addendum at the end of this document, or see the TI Web site at www.ti.com.

(1) Product Preview

Table 2. Improved Replacement Parts

Part Number	Replace With	
xxx3491 xxx3490	SN65HVD33: SN65HVD30:	Better ESD protection (15 kV vs 2 kV or not specified), higher signaling rate (25 Mbps vs 20 Mbps), fractional unit load (64 nodes vs 32)
MAX3491E MAX3490E	SN65HVD33: SN65HVD30:	Higher signaling rate (25 Mbps vs 12 Mbps), fractional unit load (64 nodes vs 32)
MAX3076E MAX3077E	SN65HVD33: SN65HVD30:	Higher signaling rate (25 Mbps vs 16 Mbps), lower standby current (1 µA vs 10 µA)
MAX3073E MAX3074E	SN65HVD34: SN65HVD31:	Higher signaling rate (5 Mbps vs 500 kbps), lower standby current (1 µA vs 10 µA)
MAX3070E MAX3071E	SN65HVD35: SN65HVD32:	Higher signaling rate (1 Mbps vs 250 kbps), lower standby current (1 µA vs 10 µA)

6 Pin Configuration and Functions

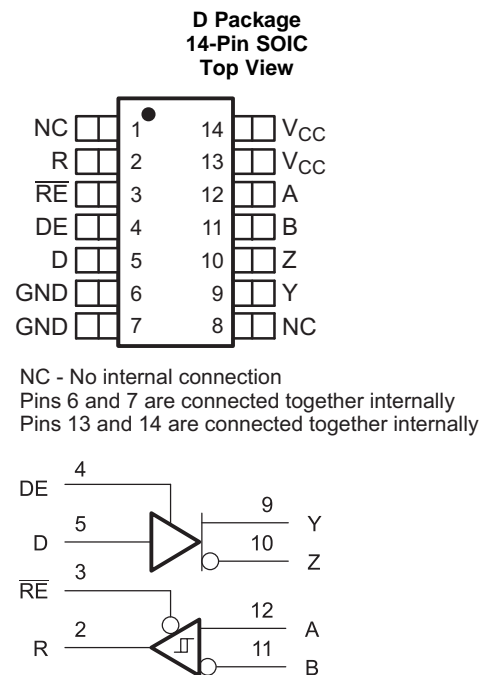
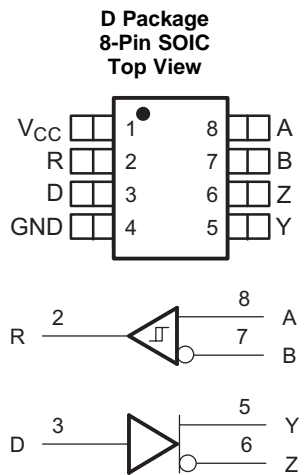

Pin Functions

NAME	PIN		TYPE	DESCRIPTION
	D (8-PIN)	D (14-PIN)		
A	8	12	Bus input	Receiver input (complementary to B)
B	7	11	Bus input	Receiver input (complementary to A)
D	3	5	Digital input	Driver data input
DE	—	4	Digital input	Driver enable, active high
GND	4	6, 7	Reference potential	Local device ground
NC	—	1, 8	No connect	No connect; must be left floating
R	2	2	Digital output	Receive data output
\overline{RE}	—	3	Digital output	Receiver enable, active low
V _{CC}	1	13, 14	Supply	3-V to 3.6-V supply
Y	5	9	Bus output	Driver output (complementary to Z)
Z	6	10	Bus output	Driver output (complementary to Y)

7 Specifications

7.1 Absolute Maximum Ratings

over operating free-air temperature range (unless otherwise noted)⁽¹⁾ ⁽²⁾

		MIN	MAX	UNIT
V_{CC}	Supply voltage range	-0.3	6	V
$V_{(A)}, V_{(B)}, V_{(Y)}, V_{(Z)}$	Voltage range at any bus terminal (A, B, Y, Z)	-9	14	V
$V_{(TRANS)}$	Voltage input, transient pulse through 100 Ω (see Figure 21) (A, B, Y, Z) ⁽³⁾	-50	50	V
V_I	Input voltage range (D, DE, \overline{RE})	-0.5	7	V
$P_{D(cont)}$	Continuous total power dissipation	Internally limited ⁽⁴⁾		
I_O	Output current (receiver output only, R)		11	mA
T_J	Junction temperature		165	°C
T_{stg}	Storage temperature range	-65	150	°C

- (1) Stresses beyond those listed under absolute maximum ratings may cause permanent damage to the device. These are stress ratings only, and functional operation of the device at these or any other conditions beyond those indicated under recommended operating conditions is not implied. Exposure to absolute-maximum-rated conditions for extended periods may affect device reliability.
- (2) All voltage values, except differential I/O bus voltages, are with respect to network ground terminal.
- (3) This tests survivability only and the output state of the receiver is not specified.
- (4) The thermal shutdown protection circuit internally limits the continuous total power dissipation. Thermal shutdown typically occurs when the junction temperature reaches 165°C.

7.2 ESD Ratings

			MIN	UNIT	
$V_{(ESD)}$	Electrostatic discharge	Human body model (HBM), per ANSI/ESDA/JEDEC JS-001, all pins ⁽¹⁾	Bus pins and GND	±16000	V
			All pins	±4000	
		Charged device model (CDM), per JEDEC specification JESD22-C101, all pins ⁽²⁾		±1000	

- (1) JEDEC document JEP155 states that 500-V HBM allows safe manufacturing with a standard ESD control process.
- (2) JEDEC document JEP157 states that 250-V CDM allows safe manufacturing with a standard ESD control process.

7.3 Recommended Operating Conditions

over operating free-air temperature range (unless otherwise noted)

		MIN	NOM	MAX	UNIT
V _{CC}	Supply voltage	3		3.6	V
V _I or V _{IC}	Voltage at any bus terminal (separately or common mode)	-7 ⁽¹⁾		12	V
1/t _{UI}	Signaling rate	'HVD30, 'HVD33		25	Mbps
		'HVD31, 'HVD34		5	
		'HVD32, 'HVD35		1	
R _L	Differential load resistance	54	60		Ω
V _{IH}	High-level input voltage	D, DE, \overline{RE}		V _{CC}	V
V _{IL}	Low-level input voltage	D, DE, \overline{RE}		0.8	V
V _{ID}	Differential input voltage	-12		12	V
I _{OH}	High-level output current	Driver		-60	mA
		Receiver		-8	
I _{OL}	Low-level output current	Driver		60	mA
		Receiver		8	
T _A	Ambient still-air temperature	-55		125 ⁽²⁾	°C

- (1) The algebraic convention, in which the least positive (most negative) limit is designated as minimum, is used in this data sheet.
 (2) Long-term high-temperature storage and/or extended use at maximum recommended operating conditions may result in a reduction of overall device life. See http://www.ti.com/ep_quality for additional information on enhanced plastic packaging.

7.4 Thermal Information

THERMAL METRIC ⁽¹⁾		D (SOIC)	D (SOIC)	UNIT
		8 PINS	14 PINS	
R _{θJA}	Junction-to-ambient thermal resistance	135	92	°C/W
R _{θJC(top)}	Junction-to-case (top) thermal resistance	43	59	°C/W
R _{θJB}	Junction-to-board thermal resistance	44	61	°C/W
ψ _{JT}	Junction-to-top characterization parameter	12.1	5.7	°C/W
ψ _{JB}	Junction-to-board characterization parameter	49.7	30.7	°C/W
R _{θJC(bot)}	Junction-to-case (bottom) thermal resistance	—	—	°C/W

- (1) For more information about traditional and new thermal metrics, see the *IC Package Thermal Metrics* application report, [SPRA953](#).

7.5 Electrical Characteristics: Driver

over recommended operating conditions (unless otherwise noted)

PARAMETER		TEST CONDITIONS		MIN	TYP ⁽¹⁾	MAX	UNIT
$V_{I(K)}$	Input clamp voltage	$I_I = -18$ mA		-1.5			V
$ V_{OD(SS)} $	Steady-state differential output voltage	$I_O = 0$		2.3		$V_{CC} + 0.1$	V
		$R_L = 54$ Ω , See Figure 10 (RS-485)		1.5	2		
		$R_L = 100$ Ω , See Figure 10 (RS-422)		2	2.3		
		$V_{test} = -7$ V to 12 V, See Figure 11		1.5			
$\Delta V_{OD(SS)} $	Change in magnitude of steady-state differential output voltage between states	$R_L = 54$ Ω , See Figure 10 and Figure 11		-0.2		0.2	V
$V_{OD(RING)}$	Differential output voltage overshoot and undershoot	$R_L = 54$ Ω , $C_L = 50$ pF, See Figure 14 and Figure 12				10% ⁽²⁾	V
$V_{OC(PP)}$	Peak-to-peak common-mode output voltage	'HVD30, 'HVD33	See Figure 13	0.5			V
		'HVD31, 'HVD32, 'HVD34, 'HVD35		0.25			
$V_{OC(SS)}$	Steady-state common-mode output voltage	See Figure 13		1.6		2.3	V
$\Delta V_{OC(SS)}$	Change in steady-state common-mode output voltage	See Figure 13		-0.05		0.05	V
$I_{Z(Z)}$ or $I_{Y(Z)}$	High-impedance state output current	'HVD30, 'HVD31, 'HVD32		$V_{CC} = 0$ V, V_Z or $V_Y = 12$ V, Other input at 0 V		90	μ A
				$V_{CC} = 0$ V, V_Z or $V_Y = -7$ V, Other input at 0 V		-10	
		'HVD33, 'HVD34, 'HVD35		Other input at 0 V		90	
				$V_{CC} = 3$ V or 0 V, DE = 0 V, V_Z or $V_Y = 12$ V		-10	
$I_{Z(S)}$ or $I_{Y(S)}$	Short-circuit output current			V_Z or $V_Y = -7$ V		± 250	mA
				V_Z or $V_Y = 12$ V			
I_I	Input current	D, DE		0		100	μ A
$C_{(OD)}$	Differential output capacitance	$V_{OD} = 0.4 \sin(4E6\pi t) + 0.5$ V, DE at 0 V		16			pF

(1) All typical values at 25°C with 3.3-V supply

(2) 10% of the peak-to-peak differential output voltage swing, per TIA/EIA-485

7.6 Electrical Characteristics: Receiver

over recommended operating conditions (unless otherwise noted)

PARAMETER		TEST CONDITIONS		MIN	TYP ⁽¹⁾	MAX	UNIT		
V_{IT+}	Positive-going differential input threshold voltage	$I_O = -8$ mA				-0.02	V		
V_{IT-}	Negative-going differential input threshold voltage	'HVD30	$I_O = 8$ mA			-0.15	V		
		'HVD33				-0.2			
V_{hys}	Hysteresis voltage ($V_{IT+} - V_{IT-}$)				50		mV		
V_{IK}	Enable-input clamp voltage	$I_I = -18$ mA				-1.5	V		
V_O	Output voltage	$V_{ID} = 200$ mV, $I_O = -8$ mA, See Figure 17				2.4	V		
		$V_{ID} = -200$ mV, $I_O = 8$ mA, See Figure 17				0.4			
$I_{O(Z)}$	High-impedance-state output current	$V_O = 0$ or V_{CC} , \overline{RE} at V_{CC}				-1	1	μ A	
I_A or I_B	Bus input current	'HVD31, 'HVD32, 'HVD34, 'HVD35	V_A or $V_B = 12$ V	Other input at 0 V	V_A or $V_B = 12$ V		0.05	0.1	mA
					V_A or $V_B = 12$ V, $V_{CC} = 0$ V		0.06	0.1	
					V_A or $V_B = -7$ V		-0.10	-0.04	
					V_A or $V_B = -7$ V, $V_{CC} = 0$ V		-0.10	-0.03	
		'HVD30, 'HVD33	V_A or $V_B = 12$ V	Other input at 0 V	V_A or $V_B = 12$ V		0.20	0.35	
					V_A or $V_B = 12$ V, $V_{CC} = 0$ V		0.24	0.4	
					V_A or $V_B = -7$ V		-0.35	-0.18	
					V_A or $V_B = -7$ V, $V_{CC} = 0$ V		-0.25	-0.13	
I_{IH}	Input current, \overline{RE}	$V_{IH} = 0.8$ V or 2 V				-60		μ A	
C_{ID}	Differential input capacitance	$V_{ID} = 0.4 \sin(4E6\pi t) + 0.5$ V, DE at 0 V				15		pF	
SUPPLY CURRENT									
I_{CC}	Supply current	'HVD30, 'HVD31, 'HVD32, 'HVD33, 'HVD34, 'HVD35	D at 0 V or V_{CC} and no load				2.1	mA	
							6.4		
					\overline{RE} at 0 V, D at 0 V or V_{CC} , DE at 0 V, No load (receiver enabled and driver disabled)		1.8		
							2.2		
		'HVD33, 'HVD34, 'HVD35	\overline{RE} at V_{CC} , D at V_{CC} , DE at 0 V, No load (receiver disabled and driver disabled)				0.022	1.5	μ A
							2.1		
					\overline{RE} at 0 V, D at 0 V or V_{CC} , DE at V_{CC} , No load (receiver enabled and driver enabled)		6.5		
							1.8		
'HVD33, 'HVD34, 'HVD35	\overline{RE} at V_{CC} , D at 0 V or V_{CC} , DE at V_{CC} , No load (receiver disabled and driver enabled)				1.8	6.2	mA		
					6.2				

(1) All typical values at 25°C with 3.3-V supply

7.7 Switching Characteristics: Driver

over recommended operating conditions (unless otherwise noted)

PARAMETER		TEST CONDITIONS	MIN	TYP ⁽¹⁾	MAX	UNIT
t _{PLH}	Propagation delay time, low- to high-level output	'HVD30, 'HVD33	4	10	23	ns
		'HVD31, 'HVD34	25	38	65	
		'HVD32, 'HVD35	120	175	305	
t _{PHL}	Propagation delay time, high- to low-level output	'HVD30, 'HVD33	4	9	23	ns
		'HVD31, 'HVD34	25	38	65	
		'HVD32, 'HVD35	120	175	305	
t _r	Differential output signal rise time	'HVD30, 'HVD33	2.5	5	18	ns
		'HVD31, 'HVD34	20	37	60	
		'HVD32, 'HVD35	120	185	300	
t _f	Differential output signal fall time	'HVD30, 'HVD33	2.5	5	18	ns
		'HVD31, 'HVD34	20	35	60	
		'HVD32, 'HVD35	120	180	300	
t _{sk(p)}	Pulse skew ((t _{PHL} – t _{PLH}))	'HVD30, 'HVD33		0.6		ns
		'HVD31, 'HVD34		2.0		
		'HVD32, 'HVD35		5.1		
t _{PZH1}	Propagation delay time, high-impedance to high-level output	'HVD33			45	ns
		'HVD34			235	
		'HVD35			490	
t _{PHZ}	Propagation delay time, high-level to high-impedance output	'HVD33			25	ns
		'HVD34			65	
		'HVD35			165	
t _{PZL1}	Propagation delay time, high-impedance to low-level output	'HVD33			35	ns
		'HVD34			190	
		'HVD35			490	
t _{PLZ}	Propagation delay time, low-level to high-impedance output	'HVD33			30	ns
		'HVD34			120	
		'HVD35			290	
t _{PZH2}	Propagation delay time, standby to high-level output	'HVD30			4000	ns
		'HVD33			5000	
t _{PZL2}	Propagation delay time, standby to low-level output	'HVD30			4000	ns
		'HVD33			5000	

(1) All typical values at 25°C with 3.3-V supply

7.8 Switching Characteristics: Receiver

over operating free-air temperature range (unless otherwise noted)

PARAMETER		TEST CONDITIONS		MIN	TYP	MAX	UNIT
t_{PLH}	Propagation delay time, low- to high-level output	'HVD30, 'HVD33			26	60	ns
		'HVD31, 'HVD32, 'HVD34, 'HVD35			47	70	
t_{PLH}	Propagation delay time, high- to low-level output	'HVD30, 'HVD33			29	60	ns
		'HVD31, 'HVD32, 'HVD34, 'HVD35			49	70	
$t_{sk(p)}$	Pulse skew ($t_{PHL} - t_{PLH}$)	'HVD30, 'HVD33		$V_{ID} = -1.5\text{ V to }1.5\text{ V},$ $C_L = 15\text{ pF},$ See Figure 18		12	ns
		'HVD31, 'HVD34, 'HVD32, 'HVD35				10	
t_r	Output signal rise time	'HVD30				10	ns
		'HVD33				18	
t_f	Output signal fall time					12.5	ns
t_{PHZ}	Output disable time from high level	DE at 3 V				20	ns
t_{PZH1}	Output enable time to high level				$C_L = 15\text{ pF},$ See Figure 19	20	ns
t_{PZH2}	Propagation delay time, standby to high-level output	'HVD30				4000	ns
		'HVD33		5000			
t_{PLZ}	Output disable time from low level	DE at 3 V			20	ns	
t_{PZL1}	Output enable time to low level			$C_L = 15\text{ pF},$ See Figure 20	20	ns	
t_{PZL2}	Propagation delay time, standby to low-level output	'HVD30			4000	ns	
		'HVD33		5000			

7.9 Receiver Equalization Characteristics

over recommended operating conditions (unless otherwise noted)

PARAMETER	TEST CONDITIONS		DEVICE	MIN	TYP ⁽¹⁾	MAX	UNIT
$t_{j(pp)}$	Peak-to-peak eye-pattern jitter	Pseudo-random NRZ code with a bit pattern length of $2^{16} - 1$, Belden 3105A cable	25 Mbps	100 m	'HVD33 ⁽²⁾	PREVIEW	ns
				150 m	'HVD33 ⁽²⁾	PREVIEW	
				200 m	'HVD33 ⁽²⁾	PREVIEW	
			10 Mbps	200 m	'HVD33 ⁽²⁾	PREVIEW	
				250 m	'HVD33 ⁽²⁾	PREVIEW	
				300 m	'HVD33 ⁽²⁾	PREVIEW	
			5 Mbps	500 m	'HVD34 ⁽²⁾	PREVIEW	
			3 Mbps	500 m	'HVD33 ⁽²⁾	PREVIEW	
					'HVD34 ⁽²⁾	PREVIEW	
1 Mbps	1000 m	'HVD34 ⁽²⁾	PREVIEW				

(1) All typical values are at $V_{CC} = 5\text{ V}$ and temperature = 25°C .

(2) The SN65HVD33-EP and the SN65HVD34-EP do not have receiver equalization, but are specified for comparison.

7.10 Dissipation Ratings

PARAMETER	DEVICE	TEST CONDITIONS	MIN	MAX	UNIT
P_D	'HVD30 (25 Mbps)	$R_L = 60\ \Omega, C_L = 50\text{ pF},$ Input to D a 50% duty cycle square wave at indicated signaling rate, $T_A = 85^\circ\text{C}$		197	mW
	'HVD31 (5 Mbps)			213	
	'HVD32 (1 Mbps)			193	
	'HVD33 (25 Mbps)	$R_L = 60\ \Omega, C_L = 50\text{ pF},$ DE at V_{CC}, \overline{RE} at 0 V, Input to D a 50% duty cycle square wave at indicated signaling rate, $T_A = 85^\circ\text{C}$		197	mW
	'HVD34 (5 Mbps)			193	
	'HVD35 (1 Mbps)			248	

7.11 Typical Characteristics

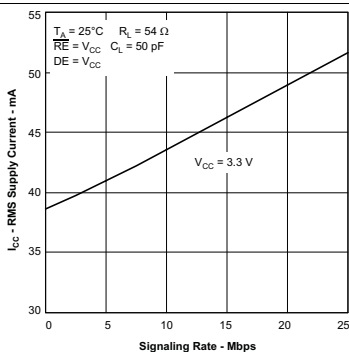

Figure 1. 'HVD30, 'HVD33 RMS Supply Current Signaling Rate

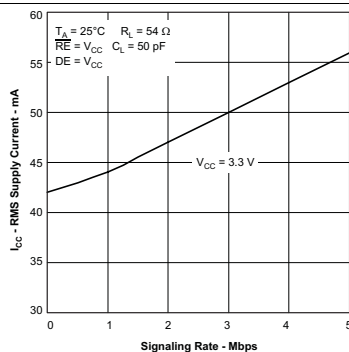

Figure 2. 'HVD31, 'HVD34 RMS Supply Current Signaling Rate

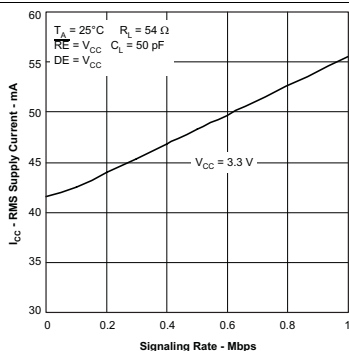

Figure 3. 'HVD32, 'HVD35 RMS Supply Current Signaling Rate

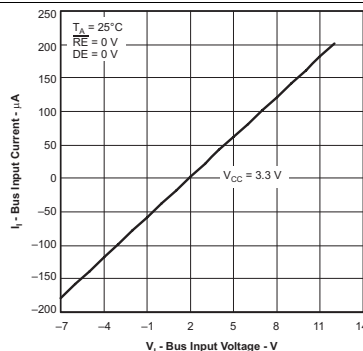

Figure 4. Bus Input Current vs Input Voltage

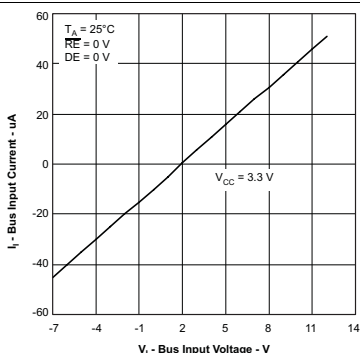

Figure 5. 'HVD31, 'HVD32, 'HVD34, 'HVD35 Bus Input Current vs Input Voltage

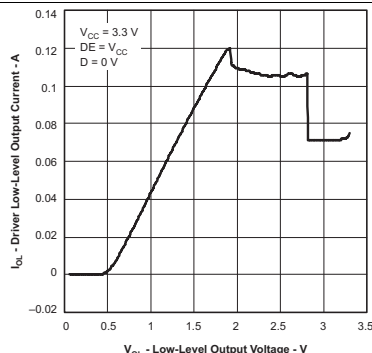

Figure 6. Driver Low-Level Output Current vs Low-Level Output Voltage

Typical Characteristics (continued)

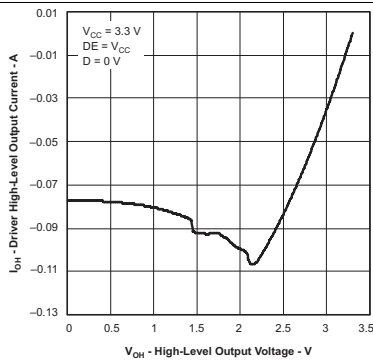

Figure 7. Driver High-Level Output Current vs High-Level Output Voltage

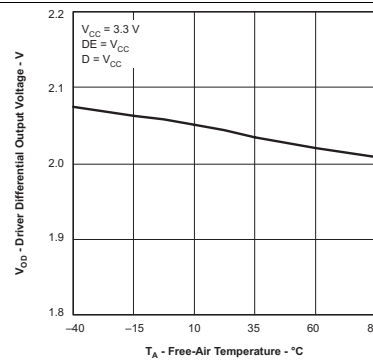

Figure 8. Driver Differential Output Voltage vs Free-Air Temperature

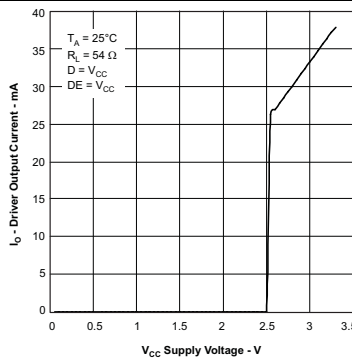

Figure 9. Driver Output Current vs Supply Voltage

8 Parameter Measurement Information

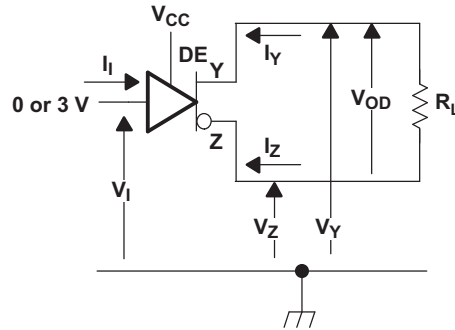

Figure 10. Driver V_{OD} Test Circuit and Voltage and Current Definitions

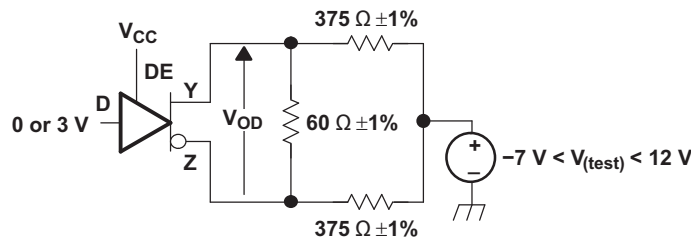

Figure 11. Driver V_{OD} With Common-Mode Loading Test Circuit

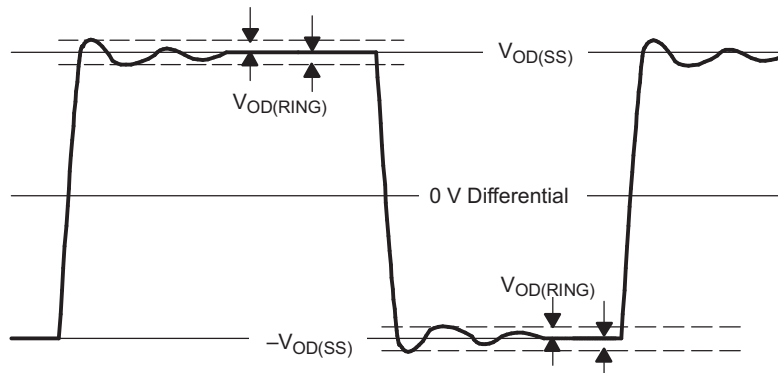
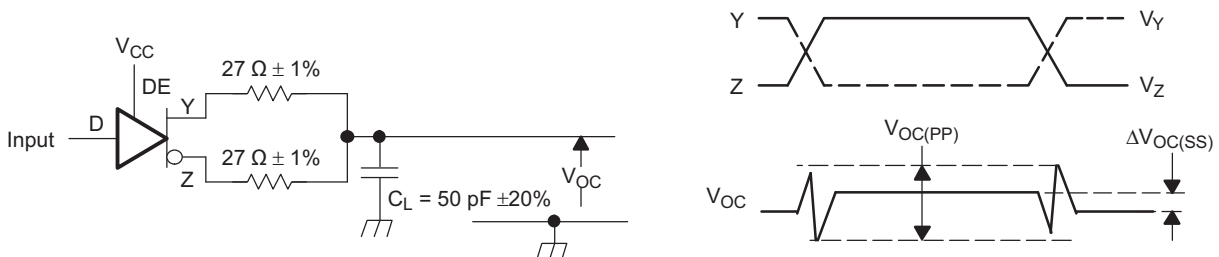

Figure 12. $V_{OD(RING)}$ Waveform and Definitions

$V_{OD(RING)}$ is measured at four points on the output waveform, corresponding to overshoot and undershoot from the $V_{OD(H)}$ and $V_{OD(L)}$ steady state values.



Input: PRR = 500 kHz, 50% Duty Cycle, $t_r < 6$ ns, $t_f < 6$ ns, $Z_O = 50 \Omega$

Figure 13. Test Circuit and Definitions for Driver Common-Mode Output Voltage

Parameter Measurement Information (continued)

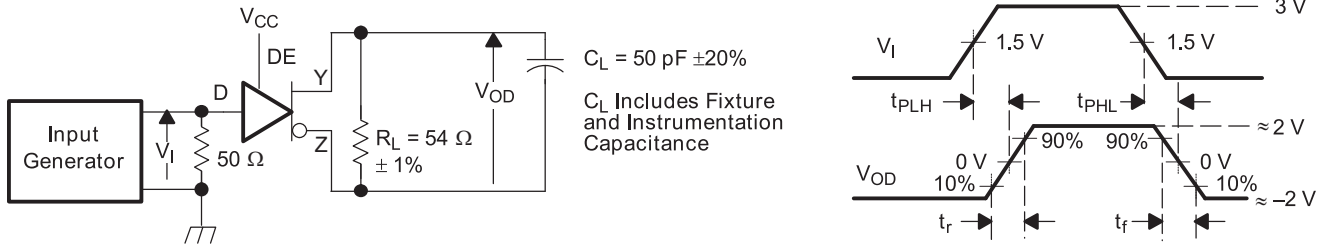

A. Generator: PRR = 500 kHz, 50% Duty Cycle, $t_r < 6$ ns, $t_f < 6$ ns, $Z_O = 50 \Omega$

Figure 14. Driver Switching Test Circuit and Voltage Waveforms

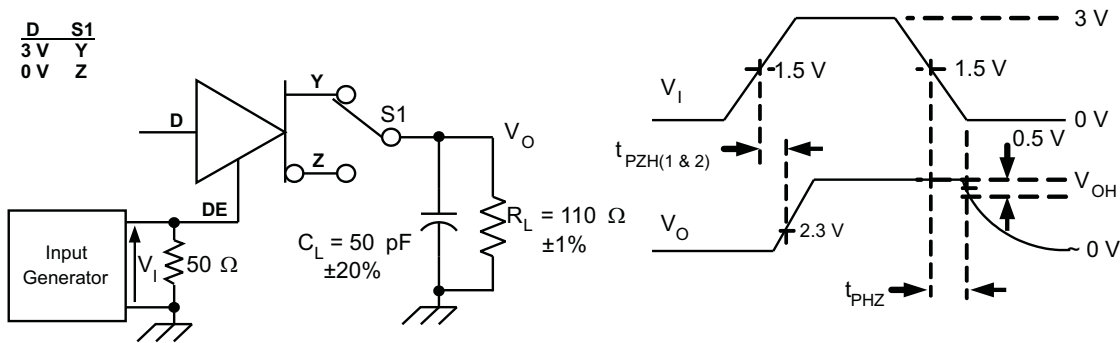

A. Generator: PRR = 500 kHz, 50% Duty Cycle, $t_r < 6$ ns, $t_f < 6$ ns, $Z_O = 50 \Omega$

B. C_L Includes Fixture and Instrumentation Capacitance

Figure 15. Driver High-Level Output Enable and Disable Time Test Circuit and Voltage Waveforms

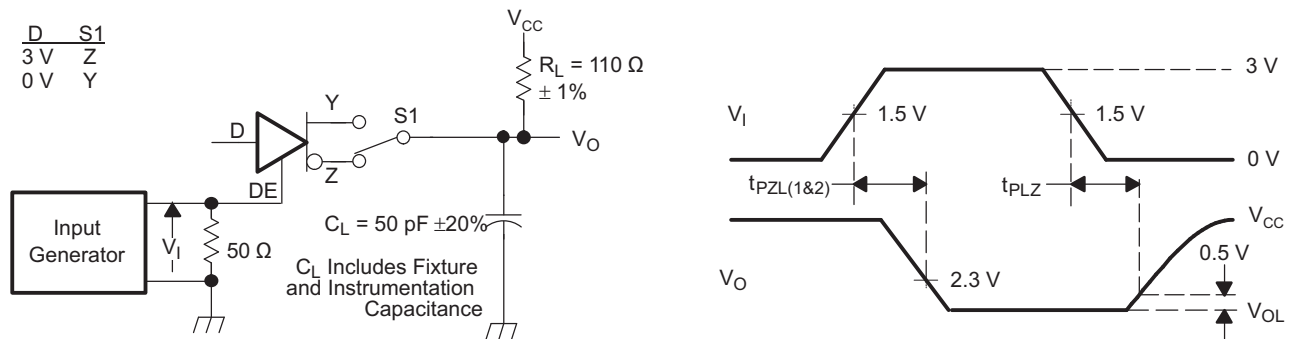

A. Generator: PRR = 500 kHz, 50% Duty Cycle, $t_r < 6$ ns, $t_f < 6$ ns, $Z_O = 50 \Omega$

Figure 16. Driver Low-Level Output Enable and Disable Time Test Circuit and Voltage Waveforms

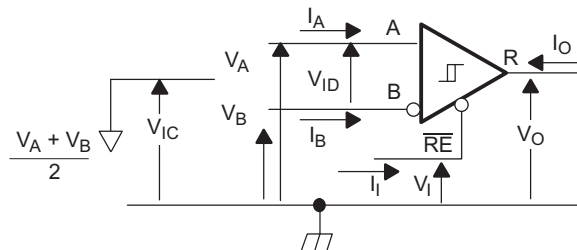
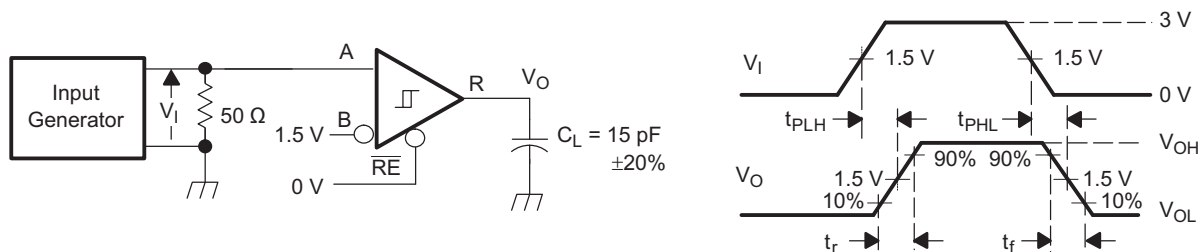

Figure 17. Receiver Voltage and Current Definitions

Parameter Measurement Information (continued)



- A. C_L Includes Fixture and Instrumentation Capacitance
- B. Generator: PRR = 500 kHz, 50% Duty Cycle, $t_r < 6$ ns, $t_f < 6$ ns, $Z_O = 50 \Omega$

Figure 18. Receiver Switching Test Circuit and Voltage Waveforms

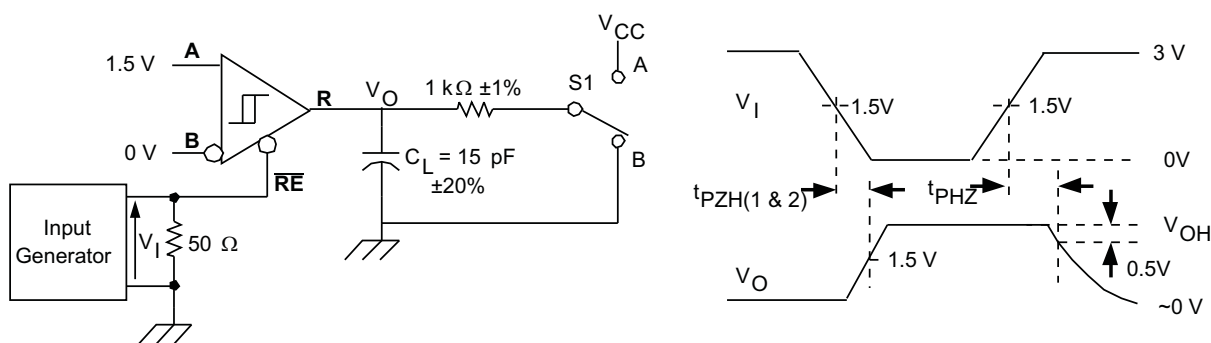

- A. Generator: PRR = 500 kHz, 50% Duty Cycle, $t_r < 6$ ns, $t_f < 6$ ns, $Z_O = 50 \Omega$

Figure 19. Receiver High-Level Enable and Disable Time Test Circuit and Voltage Waveforms

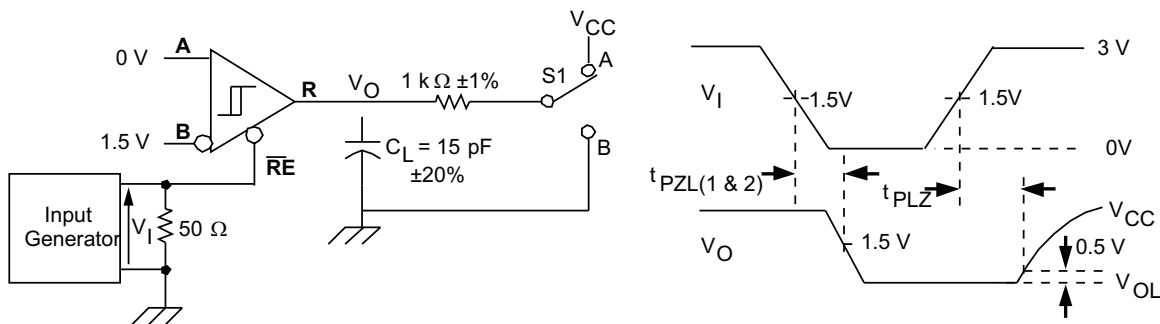

- A. Generator: PRR = 500 kHz, 50% Duty Cycle, $t_r < 6$ ns, $t_f < 6$ ns, $Z_O = 50 \Omega$

Figure 20. Receiver Enable Time From Standby (Driver Disabled)

Parameter Measurement Information (continued)

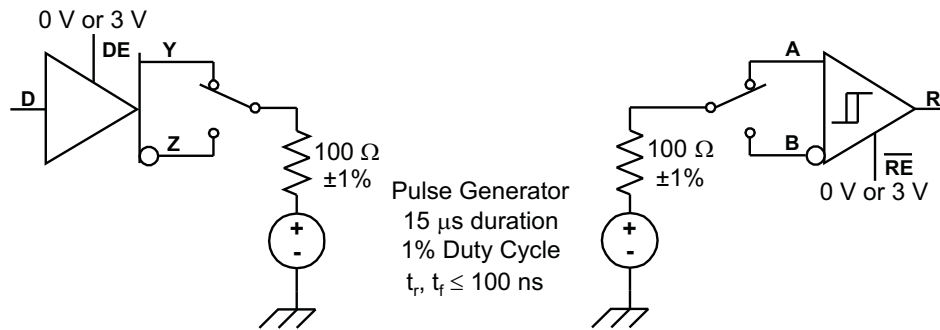

Figure 21. Test Circuit, Transient Over Voltage Test

9 Detailed Description

9.1 Overview

The SN65HVD3x-EP devices are low-power, full-duplex RS-485 transceivers available in three speed grades suitable for data transmission of 1 Mbps, 5 Mbps, and 50 Mbps.

The SN65HVD30, SN65HVD31, and SN65HVD32 devices are fully enabled with no external enabling pins. The SN65HVD33, SN65HVD34, and SN65HVD35 devices have active-high driver enables and active-low receiver enables. A standby current of less than 1 μ A can be achieved by disabling both driver and receiver.

9.2 Functional Block Diagram

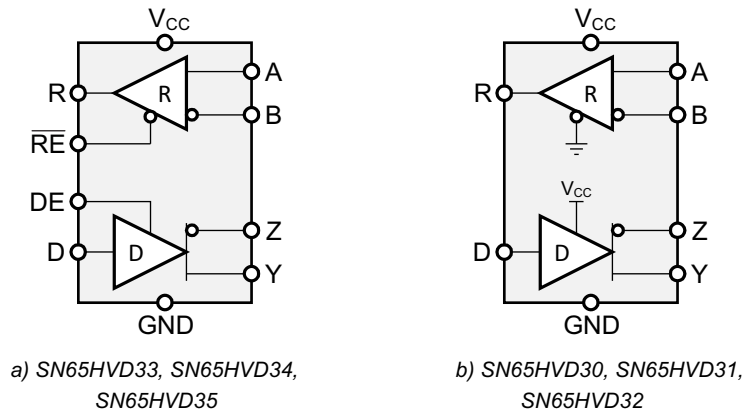

9.3 Feature Description

9.3.1 Low-Power Standby Mode

When both the driver and receiver are disabled (DE is low and \overline{RE} is high), the device is in standby mode. If the enable inputs are in this state for less than 60 ns, the device does not enter standby mode. This guards against inadvertently entering standby mode during driver or receiver enabling. The device in standby mode only when the enable inputs are held in this state for 300 ns or more. In this low-power standby mode, most internal circuitry is powered down, and the supply current is typically less than 1 nA. When either the driver or the receiver is re-enabled, the internal circuitry becomes active.

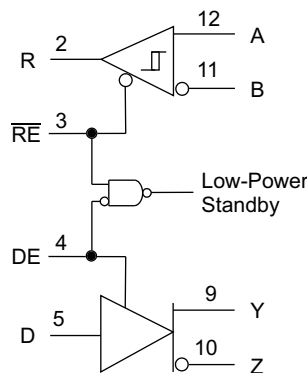

Figure 22. Low-Power Standby Logic Diagram

If only the driver is re-enabled (DE transitions to high) the driver outputs are driven according to the D input after the enable times given by t_{PZH2} and t_{PZL2} in the driver switching characteristics. If the D input is open when the driver is enabled, the driver output defaults to Y high and Z low, in accordance with the driver-failsafe feature.

Feature Description (continued)

If only the receiver is re-enabled (\overline{RE} transitions to low) the receiver output is driven according to the state of the bus inputs (A and B) after the enable times given by t_{PZH2} and t_{PZL2} in the receiver switching characteristics. If there is no valid state on the bus the receiver responds as described in the failsafe operation section.

If both the receiver and driver are re-enabled simultaneously, the receiver output is driven according to the state of the bus inputs (A and B) and the driver output is driven according to the D input. Note that the state of the active driver affects the inputs to the receiver. Therefore, the receiver outputs are valid as soon as the driver outputs are valid.

9.3.2 Driver Output Current Limiting

The RS-485 standard (ANSI/TIA/EIA-485-A or equivalently ISO 8482) specifies a 250-mA driver output current limit to prevent damage caused by data contention on the bus. That applies in the event that two or more transceivers drive the bus to opposing states at the same time. The SN65HVD3x-EP family of devices includes current-limiting circuitry that prevents damage under these conditions.

NOTE

This current limit prevents damage during the bus contention, but the logic state of the bus can be indeterminate as specified by the standard, so communication errors can occur.

In a specific combination of circumstances, a condition can occur in which current through the bus pin exceeds the 250-mA limit. This combination of conditions is not normally included in RS-485 applications:

- Loading capacitance on the pin is less than 500 pF
- The bus pin is directly connected to a voltage more negative than -1 V
- The device is supplied with V_{CC} equal to or greater than 3.3 V
- The driver is enabled
- The bus pin is driving to the logic high state

In these specific conditions, the normal current-limit circuitry and thermal-shutdown circuitry does not limit or shutdown the current flow. If the current is allowed to continue, the device heats up in a localized area near the driver outputs, and the device can be damaged.

Typical RS-485 twisted-pair cable has a capacitance of approximately 50 pF/meter. Therefore, it is expected that 10 meters of cable can provide sufficient capacitance to prevent this latch-up condition.

The -7 to $+12$ -V common mode range specified by RS-485 is intended to allow communication between transceivers separated by significant distances when ground offsets may occur due to temporary current surges, electrical noise, and so on. Under those circumstances, the inherent cable needed to connect separated transceivers ensures that the conditions previously listed do not occur. For a transceiver separated by only a short cable length or backplane applications, it is unusual for there to be a steady-state negative common-mode voltage. It is possible for a negative power supply to be shorted to the bus lines due to miswiring or cable damage; however, this is a different root cause fault, and robust devices such as the SN65HVD178x family should be used for surviving power supply or miswiring faults.

The 250-mA current limit in the RS-485 standard is intended to prevent damage caused by data contention on the bus; that is, in the event that two or more transceivers drive the bus to different states at the same time. These devices are not damaged under these conditions because all RS-485 drivers have output impedance sufficient to prevent the direct connection condition stated previously. Typical RS-485 driver output impedance is on the order of 10 Ω to 30 Ω .

9.3.3 Hot-Plugging

These devices are designed to operate in *hot swap* or *hot pluggable* applications. Key features for hot-pluggable applications are:

- Power-up
- Power-down glitch-free operation
- Default disabled input/output pins
- Receiver failsafe

Feature Description (continued)

As shown in [Figure 9](#), an internal power-on reset circuit keeps the driver outputs in a high-impedance state until the supply voltage has reached a level at which the device reliably operates. This ensures that no spurious bits are transmitted on the bus pin outputs as the power supply turns on or turns off.

As shown in the [Device Functional Modes](#), the enable inputs have the feature of default disable on both the driver enable and receiver enable. This ensures that the device neither drives the bus nor reports data on the R pin until the associated controller actively drives the enable pins.

9.3.4 Receiver Failsafe

The differential receivers of the SN65HVD3x-EP family are failsafe to invalid bus states caused by:

- Open bus conditions such as a disconnected connector
- Shorted bus conditions such as cable damage shorting the twisted-pair together
- Idle bus conditions that occur when no driver on the bus is actively driving

In any of these cases, the differential receiver outputs a failsafe logic high state so that the output of the receiver is not indeterminate.

Receiver failsafe is accomplished by offsetting the receiver thresholds such that the input indeterminate range does not include zero volts differential. In order to comply with the RS-422 and RS-485 standards, the receiver output must output a high when the differential input V_{ID} is more positive than 200 mV, and must output a low when V_{ID} is more negative than -200 mV. The receiver parameters which determine the failsafe performance are V_{IT+} , V_{IT-} , and V_{HYS} (the separation between V_{IT+} and V_{IT-}). As shown in the [Electrical Characteristics: Receiver](#) table, differential signals more negative than -200 mV always cause a low receiver output, and differential signals more positive than 200 mV always cause a high receiver output.

When the differential input signal is close to zero, it is still above the V_{IT+} threshold, and the receiver output is high. Only when the differential input is more than V_{HYS} below V_{IT+} does the receiver output transition to a low state. Therefore, the noise immunity of the receiver inputs during a bus fault conditions includes the receiver hysteresis value (V_{HYS}) as well as the value of V_{IT+} .

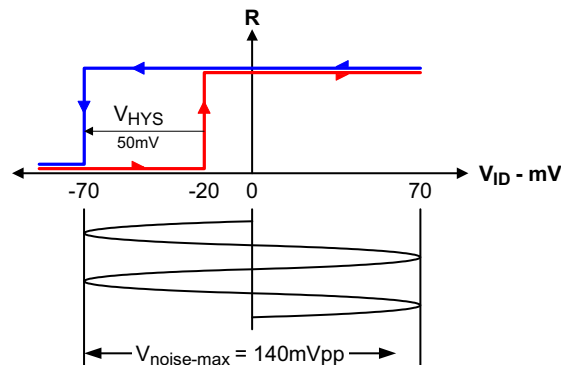

Figure 23. SN65HVD30-35 Noise Immunity Under Bus Fault Conditions

9.3.5 Safe Operation With Bus Contention

These devices incorporate a driver current limit of 250 mA across the RS-485 common-mode range of -7 V to $+12$ V. As stated in the [Application Guidelines for TIA/EIA-485-A](#) ⁽¹⁾, this sets a practical limitation to prevent damage during bus contention events. Contention can occur during system initialization, during system faults, or whenever two or more drivers are active at the same time.

(1) TIA/EIA Telecommunications System Bulletin TSB89, [Application Guidelines for TIA/EIA-485-A](#)

Feature Description (continued)

Figure 24 shows a 2-node system to demonstrate bus contention by forcing both drivers to be active in opposing states.

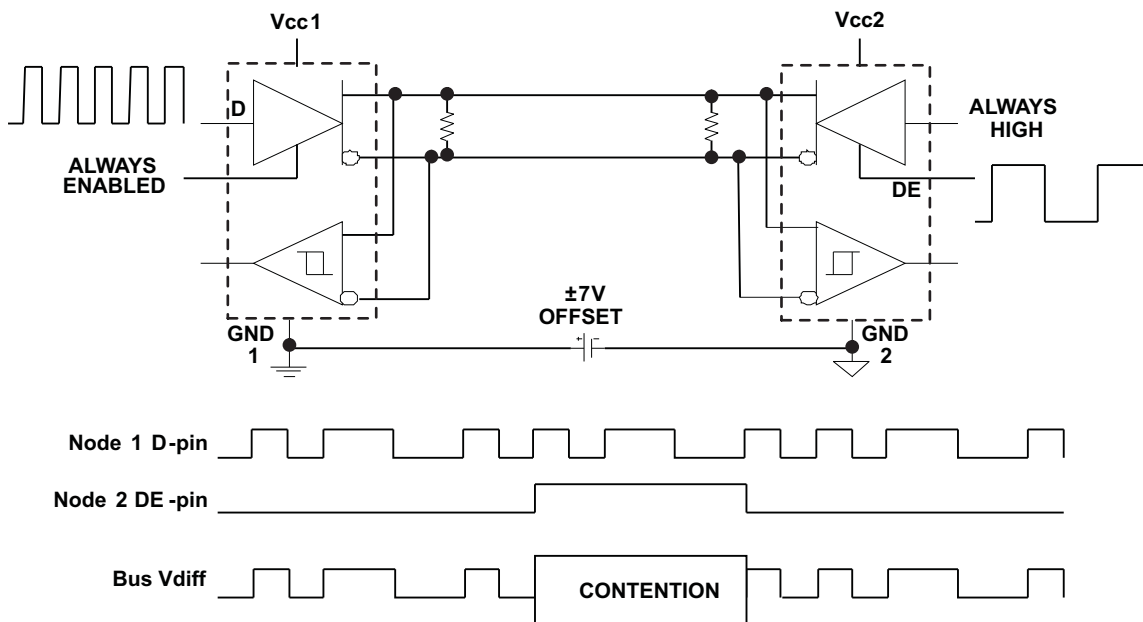

Figure 24. Bus Contention Example

Figure 25 shows typical operation in a bus contention event. The bottom trace illustrates how the SN65HVD33 device at Node 1 continues normal operation after a contention event between the two drivers with a -7-V ground offset on Node 2. This illustrates how the SN65HVD3x-EP family of devices operates robustly in spite of bus contention faults, even with large common-mode offsets.

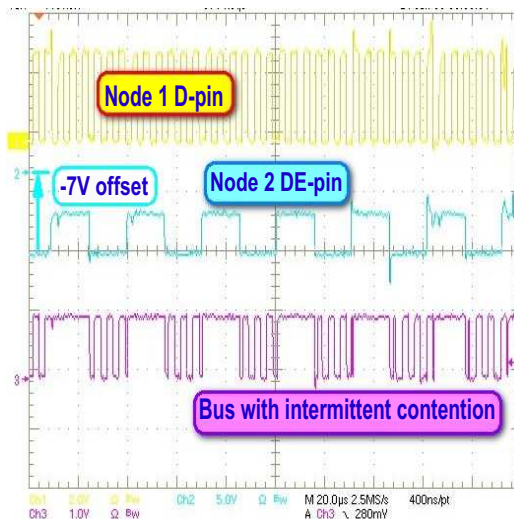

Figure 25. SN65HVD3x-EP Drivers Operate Correctly After Bus Contention Faults

9.4 Device Functional Modes

Table 3-Table 6 list the functional modes of the S65HVDxx Devices.

Table 3. SN65HVD33, SN65HVD34, SN65HVD35 Driver

INPUTS		OUTPUTS	
D	DE	Y	Z
H	H	H	L
L	H	L	H
X	L or open	Z	Z
Open	H	L	H

Table 4. SN65HVD33, SN65HVD34, SN65HVD35 Receiver

DIFFERENTIAL INPUTS $V_{ID} = V_{(A)} - V_{(B)}$	ENABLE RE	OUTPUT R
$V_{ID} \leq -0.2\text{ V}$	L	L
$-0.2\text{ V} < V_{ID} < -0.02\text{ V}$	L	—
$-0.02\text{ V} \leq V_{ID}$	L	H
X	H or open	Z
Open Circuit	L	H
Idle circuit	L	H
Short Circuit, $V_{(A)} = V_{(B)}$	L	H

Table 5. SN65HVD30, SN65HVD31, SN65HVD32 Driver

INPUT D	OUTPUTS	
	Y	Z
H	H	L
L	L	H
Open	L	H

Table 6. SN65HVD30, SN65HVD31, SN65HVD32 Receiver

DIFFERENTIAL INPUTS $V_{ID} = V_{(A)} - V_{(B)}$	OUTPUT R
$V_{ID} \leq -0.2\text{ V}$	L
$-0.02\text{ V} \leq V_{ID}$	H
Open Circuit	H
Idle circuit	H
Short Circuit, $V_{(A)} = V_{(B)}$	H

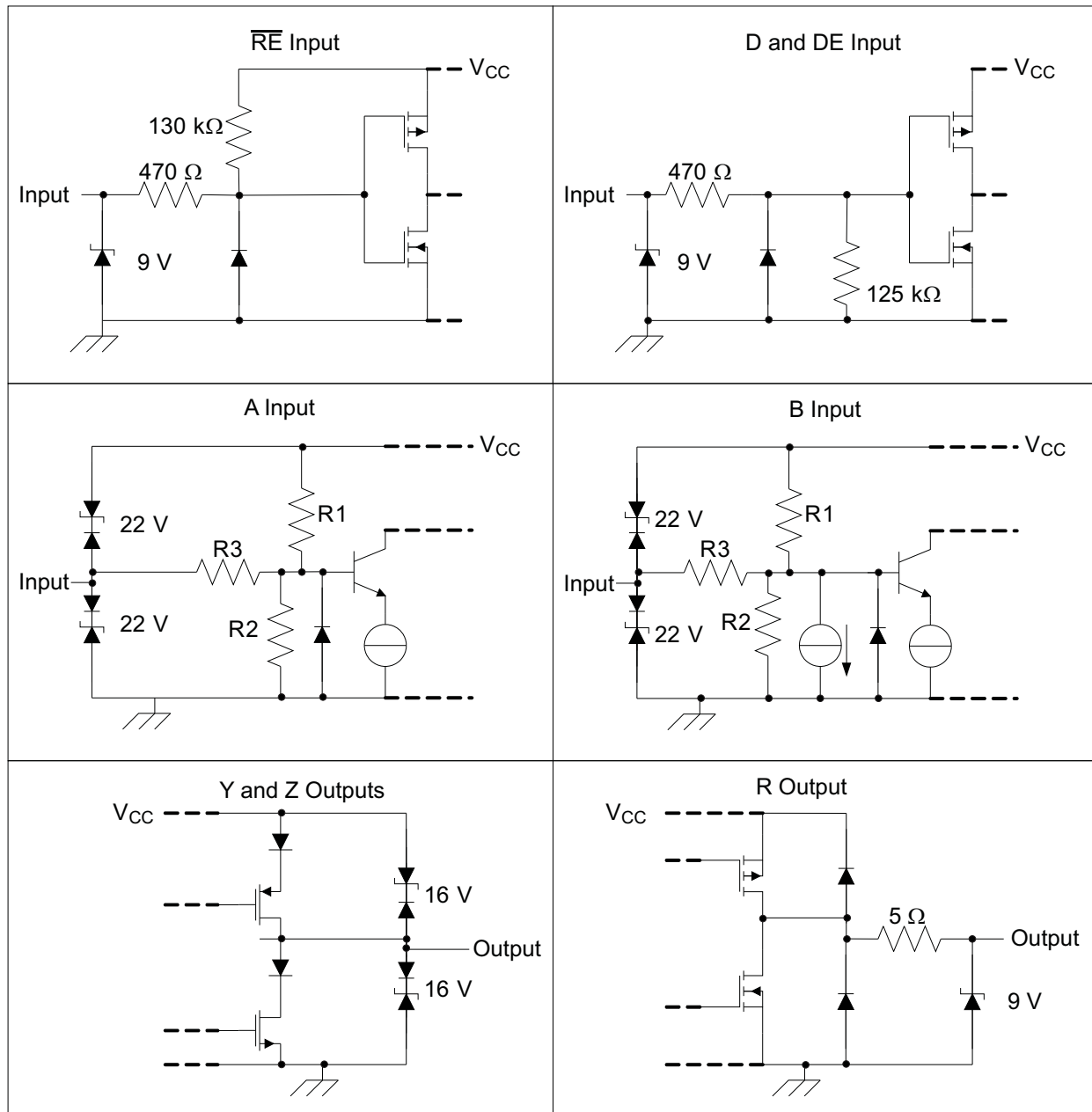

Figure 26. Equivalent Input and Output Schematic Diagrams

Table 7. Input Attenuator Resistance Values

PART NUMBER	R1, R2	R3
SN65HVD30, SN65HVD33	9 kΩ	45 kΩ
SN65HVD31, SN65HVD32, SN65HVD34, SN65HVD35	36 kΩ	180 kΩ

10 Application and Implementation

NOTE

Information in the following applications sections is not part of the TI component specification, and TI does not warrant its accuracy or completeness. TI's customers are responsible for determining suitability of components for their purposes. Customers should validate and test their design implementation to confirm system functionality.

10.1 Application Information

The SN65HVD3x-EP family consists of full-duplex RS-485 transceivers commonly used for asynchronous data transmissions. Full-duplex implementation requires two signal pairs (four wires), and allows each node to transmit data on one pair while simultaneously receiving data on the other pair.

To eliminate line reflections, each cable end is terminated with a termination resistor (R_T) whose value matches the characteristic impedance (Z_0) of the cable. This method, known as parallel termination, allows for higher data rates over longer cable length.

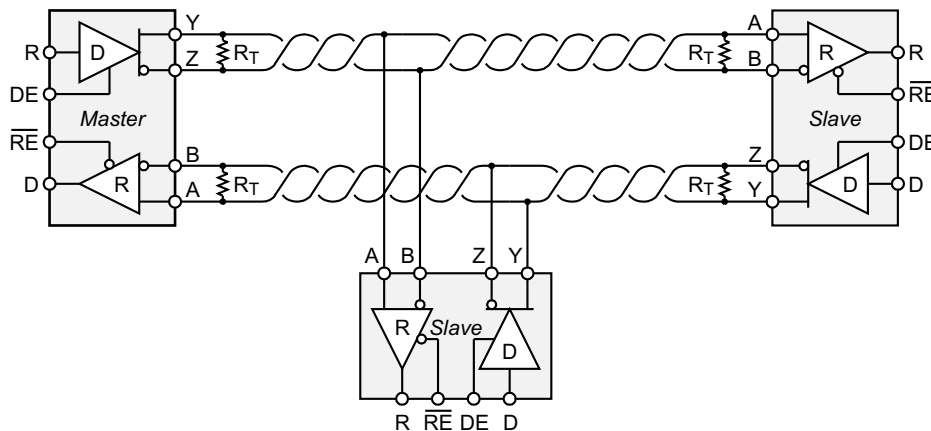

Figure 27. Typical RS-485 Network With Full-Duplex Transceivers

10.2 Typical Application

A full-duplex RS-485 network consists of multiple transceivers connecting in parallel to two bus cables. On one signal pair, a master driver transmits data to multiple slave receivers. The master driver and slave receivers can remain fully enabled at all times. On the other signal pair, multiple slave drivers transmit data to the master receiver. To avoid bus contention, the slave drivers must be intermittently enabled and disabled such that only one driver is enabled at any time, as in half-duplex communication. The master receiver can remain fully enabled at all times.

Because the driver cannot be disabled, only connect one driver to the bus when using the SN65HVD30, SN65HVD31, or SN65HVD32 devices.

Typical Application (continued)

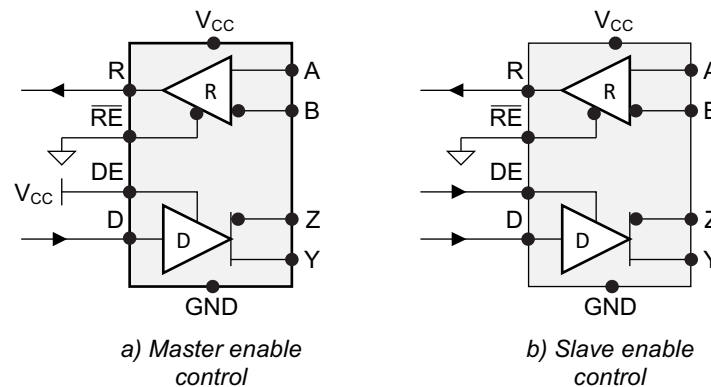

Figure 28. Full-Duplex Transceiver Configurations

10.2.1 Design Requirements

RS-485 is a robust electrical standard suitable for long-distance networking that may be used in a wide range of applications with varying requirements, such as distance, data rate, and number of nodes.

10.2.1.1 Data Rate and Bus Length

There is an inverse relationship between data rate and bus length, meaning the higher the data rate, the shorter the cable length; and conversely, the lower the data rate, the longer the cable can be without introducing data errors. While most RS-485 systems use data rates between 10 kbps and 100 kbps, some applications require data rates up to 250 kbps at distances of 4000 feet and longer. Longer distances are possible by allowing for small signal jitter of up to 5 or 10%.

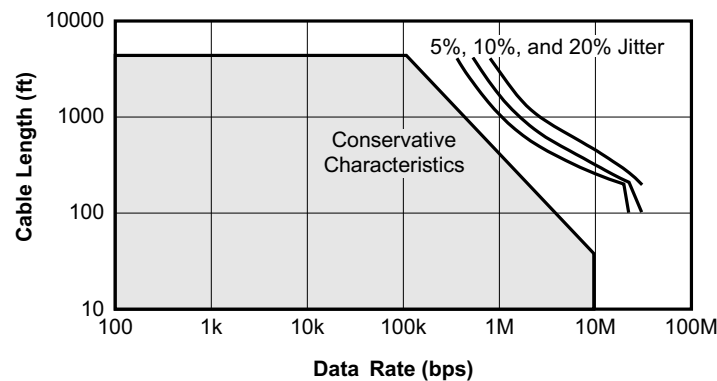

Figure 29. Cable Length vs Data Rate Characteristic

Even higher data rates are achievable (such as 26 Mbps for the SN65HVD30 and SN65HVD33 devices) in cases where the interconnect is short enough (or has suitably low attenuation at signal frequencies) to not degrade the data.

Typical Application (continued)

10.2.1.2 Stub Length

When connecting a node to the bus, the distance between the transceiver inputs and the cable trunk, known as the stub, must be as short as possible. Stubs present a nonterminated piece of bus line that can introduce reflections as the length of the stub increases. As a general guideline, the electrical length, or round-trip delay, of a stub must be less than one-tenth of the rise time of the driver; thus giving a maximum physical stub length as shown in [Equation 1](#).

$$L_{\text{stub}} \leq 0.1 \times t_r \times v \times c$$

where:

- t_r is the 10/90 rise time of the driver
 - c is the speed of light (3×10^8 m/s)
 - v is the signal velocity of the cable or trace as a factor of c
- (1)

Per [Equation 1](#), [Table 8](#) shows the maximum cable-stub lengths for the minimum driver output rise times of the SN65HVD3x-EP full-duplex family of transceivers for a signal velocity of 78%.

Table 8. Maximum Stub Length

DEVICE	MINIMUM DRIVER OUTPUT RISE TIME (ns)	MAXIMUM STUB LENGTH	
		(m)	(ft)
SN65HVD30	4	0.1	0.3
SN65HVD31	25	0.6	1.9
SN65HVD32	120	2.8	9.2
SN65HVD33	4	0.1	0.3
SN65HVD34	25	0.6	1.9
SN65HVD35	120	2.8	9.2

10.2.1.3 Bus Loading

The RS-485 standard specifies that a compliant driver must be able to driver 32 unit loads (UL), where 1 unit load represents a load impedance of approximately 12 kΩ. Because the SN65HVD30 and SN65HVD33 devices are 1/2 UL transceivers, it is possible to connect up to 64 receivers to the bus. Likewise, the SN65HVD31, SN65HVD32, SN65HVD34, and SN65HVD35 devices are 1/8 UL transceivers that can support up to 256 receivers.

10.2.2 Detailed Design Procedure

To protect bus nodes against high-energy transients, the implementation of external transient protection devices is necessary (see Figure 30).

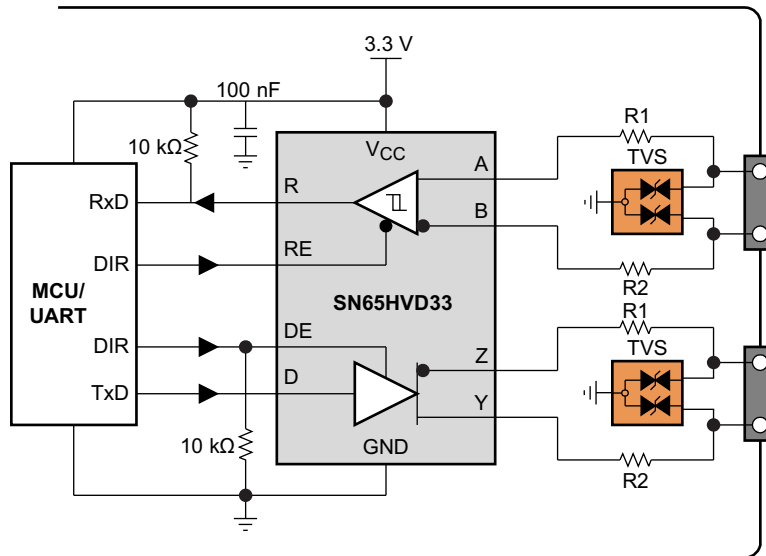
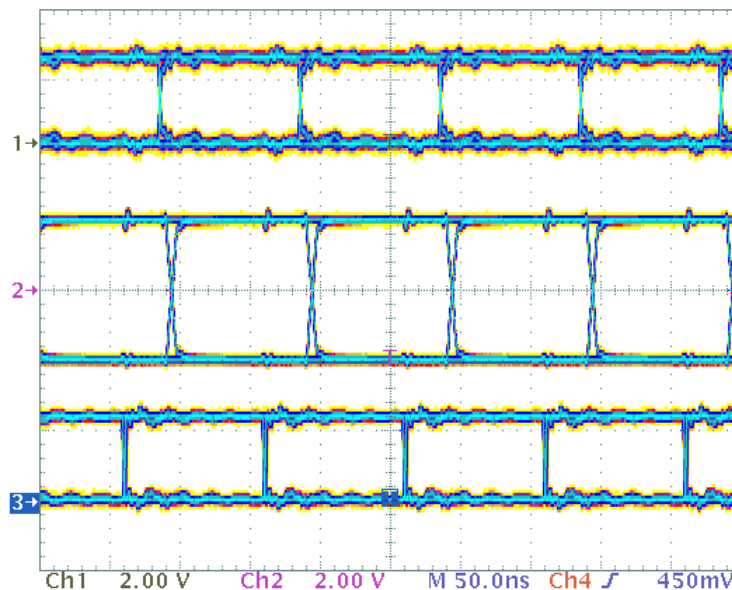

Figure 30. Transient Protection Against ESD, EFT, and Surge Transients

Table 9. Bill of Materials

DEVICE	FUNCTION	ORDER NUMBER	MANUFACTURER
XCVR	3.3-V Full-Duplex RS-485 Transceiver	SN65HVD33	TI
R1, R2	10-Ω, Pulse-Proof Thick-Film Resistor	CRCW060310RJNEAHP	Vishay
TVS	Bidirectional 400-W Transient Suppressor	CDSOT23-SM712	Bourns

10.2.3 Application Curve



Signals from top to bottom: D, Y, Z, VOD

Figure 31. SN65HVD33-EP Transient Waveform

11 Power Supply Recommendations

To ensure reliable operation at all data rates and supply voltages, each supply must be decoupled with a 100-nF ceramic capacitor located as close as possible to the supply pins. This helps to reduce supply voltage ripple present on the outputs of switched-mode power supplies and also helps compensate for the resistance and inductance of the PCB power planes.

12 Layout

12.1 Layout Guidelines

Robust and reliable bus-node design often requires the use of external transient protection devices to protect against EFT and surge transients that can occur in industrial environments. Because these transients have a wide frequency bandwidth (from approximately 3 MHz to 3 GHz), high-frequency layout techniques must be applied during PCB design.

- Place the protection circuitry close to the bus connector to prevent noise transients from entering the board.
- Use V_{CC} and ground planes to provide low-inductance. High-frequency currents follow the path of least inductance and not the path of least impedance.
- Design the protection components into the direction of the signal path. Do not force the transients currents to divert from the signal path to reach the protection device.
- Apply 100-nF to 220-nF bypass capacitors as close as possible to the V_{CC} pins of transceiver, UART, and controller ICs on the board.
- Use at least two vias for V_{CC} and ground connections of bypass capacitors and protection devices to minimize effective via inductance.
- Use 1-k Ω to 10-k Ω pullup or pulldown resistors for enable lines to limit noise currents in these lines during transient events.
- Insert series pulse-proof resistors into the A and B bus lines if the TVS clamping voltage is higher than the specified maximum voltage of the transceiver bus pins. These resistors limit the residual clamping current into the transceiver and prevent it from latching up.
- While pure TVS protection is sufficient for surge transients up to 1 kV, higher transients require metal-oxide varistors (MOVs), which reduces the transients to a few hundred volts of clamping voltage and transient blocking units (TBUs) that limit transient current to 200 mA.

12.2 Layout Example

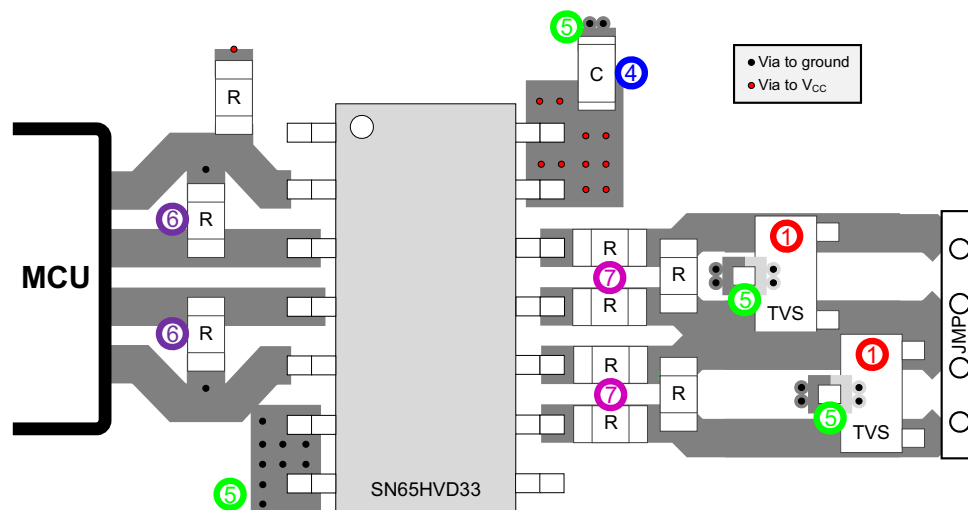

Figure 32. SN65HVD33-EP Layout Example

13 Device and Documentation Support

13.1 Related Links

The table below lists quick access links. Categories include technical documents, support and community resources, tools and software, and quick access to sample or buy.

Table 10. Related Links

PARTS	PRODUCT FOLDER	SAMPLE & BUY	TECHNICAL DOCUMENTS	TOOLS & SOFTWARE	SUPPORT & COMMUNITY
SN65HVD30-EP	Click here	Click here	Click here	Click here	Click here
SN65HVD31-EP	Click here	Click here	Click here	Click here	Click here
SN65HVD32-EP	Click here	Click here	Click here	Click here	Click here
SN65HVD33-EP	Click here	Click here	Click here	Click here	Click here
SN65HVD34-EP	Click here	Click here	Click here	Click here	Click here
SN65HVD35-EP	Click here	Click here	Click here	Click here	Click here

13.2 Community Resources

The following links connect to TI community resources. Linked contents are provided "AS IS" by the respective contributors. They do not constitute TI specifications and do not necessarily reflect TI's views; see TI's [Terms of Use](#).

TI E2E™ Online Community *TI's Engineer-to-Engineer (E2E) Community*. Created to foster collaboration among engineers. At e2e.ti.com, you can ask questions, share knowledge, explore ideas and help solve problems with fellow engineers.

Design Support *TI's Design Support* Quickly find helpful E2E forums along with design support tools and contact information for technical support.

13.3 Trademarks

E2E is a trademark of Texas Instruments.
 All other trademarks are the property of their respective owners.

13.4 Electrostatic Discharge Caution



These devices have limited built-in ESD protection. The leads should be shorted together or the device placed in conductive foam during storage or handling to prevent electrostatic damage to the MOS gates.

13.5 Glossary

[SLYZ022](#) — *TI Glossary*.

This glossary lists and explains terms, acronyms, and definitions.

14 Mechanical, Packaging, and Orderable Information

The following pages include mechanical, packaging, and orderable information. This information is the most current data available for the designated devices. This data is subject to change without notice and revision of this document. For browser-based versions of this data sheet, refer to the left-hand navigation.

PACKAGING INFORMATION

Orderable Device	Status (1)	Package Type	Package Drawing	Pins	Package Qty	Eco Plan (2)	Lead/Ball Finish (6)	MSL Peak Temp (3)	Op Temp (°C)	Device Marking (4/5)	Samples
SN65HVD30MDREP	ACTIVE	SOIC	D	8	2500	Green (RoHS & no Sb/Br)	CU NIPDAU	Level-1-260C-UNLIM	-55 to 125	HVD30EP	Samples
SN65HVD30MDREPG4	ACTIVE	SOIC	D	8	2500	Green (RoHS & no Sb/Br)	CU NIPDAU	Level-1-260C-UNLIM	-55 to 125	HVD30EP	Samples
SN65HVD33MDREP	ACTIVE	SOIC	D	14	2500	Green (RoHS & no Sb/Br)	CU NIPDAU	Level-1-260C-UNLIM	-55 to 125	HVD33EP	Samples
SN65HVD33MDREPG4	ACTIVE	SOIC	D	14	2500	Green (RoHS & no Sb/Br)	CU NIPDAU	Level-1-260C-UNLIM	-55 to 125	HVD33EP	Samples
V62/06634-01XE	ACTIVE	SOIC	D	8	2500	Green (RoHS & no Sb/Br)	CU NIPDAU	Level-1-260C-UNLIM	-55 to 125	HVD30EP	Samples
V62/06634-04YE	ACTIVE	SOIC	D	14	2500	Green (RoHS & no Sb/Br)	CU NIPDAU	Level-1-260C-UNLIM	-55 to 125	HVD33EP	Samples

(1) The marketing status values are defined as follows:

ACTIVE: Product device recommended for new designs.

LIFEBUY: TI has announced that the device will be discontinued, and a lifetime-buy period is in effect.

NRND: Not recommended for new designs. Device is in production to support existing customers, but TI does not recommend using this part in a new design.

PREVIEW: Device has been announced but is not in production. Samples may or may not be available.

OBSELETE: TI has discontinued the production of the device.

(2) Eco Plan - The planned eco-friendly classification: Pb-Free (RoHS), Pb-Free (RoHS Exempt), or Green (RoHS & no Sb/Br) - please check <http://www.ti.com/productcontent> for the latest availability information and additional product content details.

TBD: The Pb-Free/Green conversion plan has not been defined.

Pb-Free (RoHS): TI's terms "Lead-Free" or "Pb-Free" mean semiconductor products that are compatible with the current RoHS requirements for all 6 substances, including the requirement that lead not exceed 0.1% by weight in homogeneous materials. Where designed to be soldered at high temperatures, TI Pb-Free products are suitable for use in specified lead-free processes.

Pb-Free (RoHS Exempt): This component has a RoHS exemption for either 1) lead-based flip-chip solder bumps used between the die and package, or 2) lead-based die adhesive used between the die and leadframe. The component is otherwise considered Pb-Free (RoHS compatible) as defined above.

Green (RoHS & no Sb/Br): TI defines "Green" to mean Pb-Free (RoHS compatible), and free of Bromine (Br) and Antimony (Sb) based flame retardants (Br or Sb do not exceed 0.1% by weight in homogeneous material)

(3) MSL, Peak Temp. - The Moisture Sensitivity Level rating according to the JEDEC industry standard classifications, and peak solder temperature.

(4) There may be additional marking, which relates to the logo, the lot trace code information, or the environmental category on the device.

(5) Multiple Device Markings will be inside parentheses. Only one Device Marking contained in parentheses and separated by a "~" will appear on a device. If a line is indented then it is a continuation of the previous line and the two combined represent the entire Device Marking for that device.

⁽⁶⁾ Lead/Ball Finish - Orderable Devices may have multiple material finish options. Finish options are separated by a vertical ruled line. Lead/Ball Finish values may wrap to two lines if the finish value exceeds the maximum column width.

Important Information and Disclaimer: The information provided on this page represents TI's knowledge and belief as of the date that it is provided. TI bases its knowledge and belief on information provided by third parties, and makes no representation or warranty as to the accuracy of such information. Efforts are underway to better integrate information from third parties. TI has taken and continues to take reasonable steps to provide representative and accurate information but may not have conducted destructive testing or chemical analysis on incoming materials and chemicals. TI and TI suppliers consider certain information to be proprietary, and thus CAS numbers and other limited information may not be available for release.

In no event shall TI's liability arising out of such information exceed the total purchase price of the TI part(s) at issue in this document sold by TI to Customer on an annual basis.

OTHER QUALIFIED VERSIONS OF SN65HVD30-EP, SN65HVD33-EP :

- Catalog: [SN65HVD30](#), [SN65HVD33](#)

NOTE: Qualified Version Definitions:

- Catalog - TI's standard catalog product

TAPE AND REEL INFORMATION



QUADRANT ASSIGNMENTS FOR PIN 1 ORIENTATION IN TAPE



*All dimensions are nominal

Device	Package Type	Package Drawing	Pins	SPQ	Reel Diameter (mm)	Reel Width W1 (mm)	A0 (mm)	B0 (mm)	K0 (mm)	P1 (mm)	W (mm)	Pin1 Quadrant
SN65HVD30MDREP	SOIC	D	8	2500	330.0	12.4	6.4	5.2	2.1	8.0	12.0	Q1
SN65HVD33MDREP	SOIC	D	14	2500	330.0	16.4	6.5	9.0	2.1	8.0	16.0	Q1

TAPE AND REEL BOX DIMENSIONS

*All dimensions are nominal

Device	Package Type	Package Drawing	Pins	SPQ	Length (mm)	Width (mm)	Height (mm)
SN65HVD30MDREP	SOIC	D	8	2500	367.0	367.0	35.0
SN65HVD33MDREP	SOIC	D	14	2500	333.2	345.9	28.6

D (R-PDSO-G14)

PLASTIC SMALL OUTLINE



4040047-5/M 06/11

- NOTES:
- A. All linear dimensions are in inches (millimeters).
 - B. This drawing is subject to change without notice.
 - $\triangle C$ Body length does not include mold flash, protrusions, or gate burrs. Mold flash, protrusions, or gate burrs shall not exceed 0.006 (0,15) each side.
 - $\triangle D$ Body width does not include interlead flash. Interlead flash shall not exceed 0.017 (0,43) each side.
 - E. Reference JEDEC MS-012 variation AB.

D (R-PDSO-G14)

PLASTIC SMALL OUTLINE



4211283-3/E 08/12

- NOTES:
- All linear dimensions are in millimeters.
 - This drawing is subject to change without notice.
 - Publication IPC-7351 is recommended for alternate designs.
 - Laser cutting apertures with trapezoidal walls and also rounding corners will offer better paste release. Customers should contact their board assembly site for stencil design recommendations. Refer to IPC-7525 for other stencil recommendations.
 - Customers should contact their board fabrication site for solder mask tolerances between and around signal pads.

D (R-PDSO-G8)

PLASTIC SMALL OUTLINE

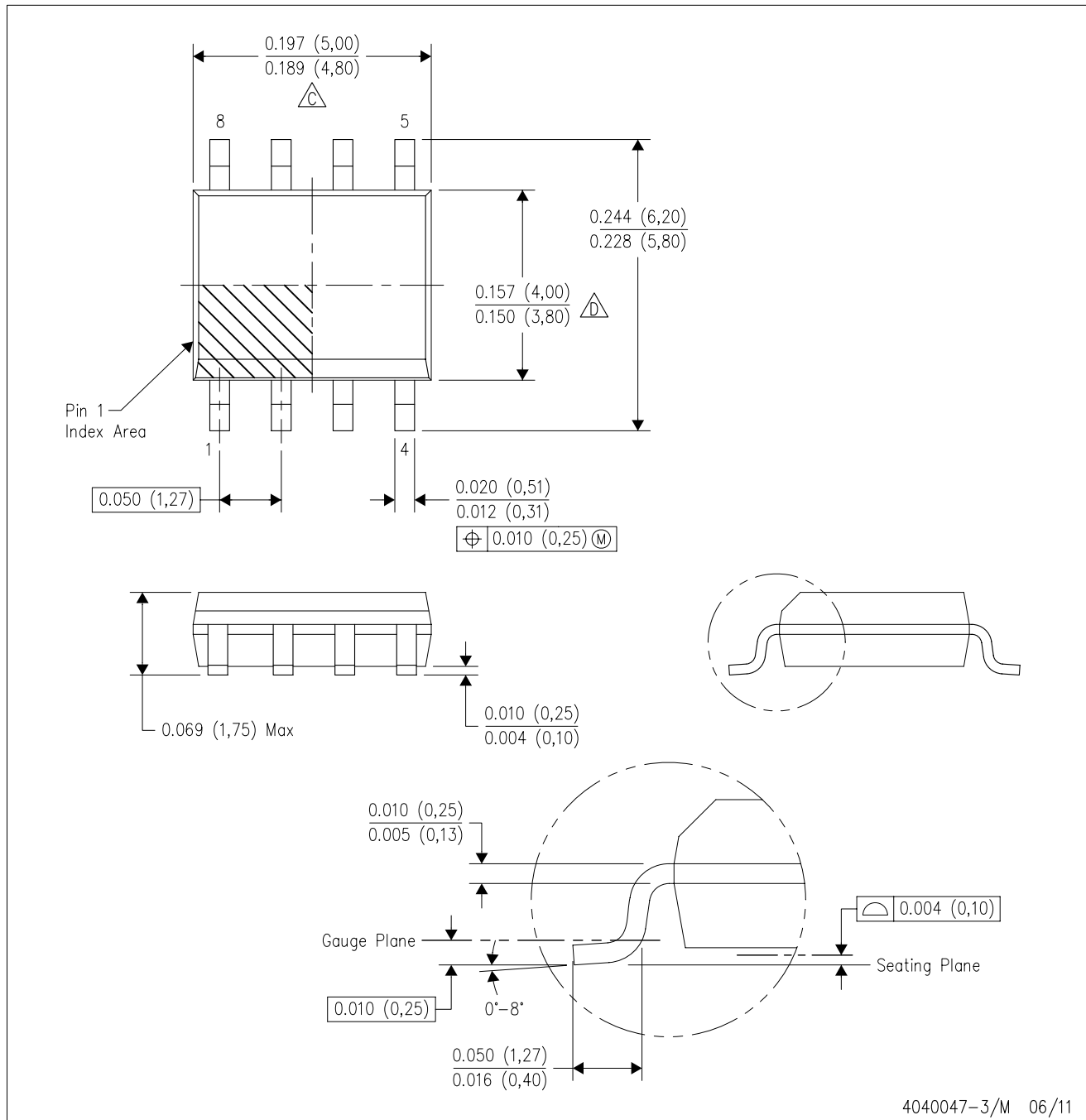

- NOTES:
- A. All linear dimensions are in inches (millimeters).
 - B. This drawing is subject to change without notice.
 - C. Body length does not include mold flash, protrusions, or gate burrs. Mold flash, protrusions, or gate burrs shall not exceed 0.006 (0,15) each side.
 - D. Body width does not include interlead flash. Interlead flash shall not exceed 0.017 (0,43) each side.
 - E. Reference JEDEC MS-012 variation AA.

D (R-PDSO-G8)

PLASTIC SMALL OUTLINE



- NOTES:
- A. All linear dimensions are in millimeters.
 - B. This drawing is subject to change without notice.
 - C. Publication IPC-7351 is recommended for alternate designs.
 - D. Laser cutting apertures with trapezoidal walls and also rounding corners will offer better paste release. Customers should contact their board assembly site for stencil design recommendations. Refer to IPC-7525 for other stencil recommendations.
 - E. Customers should contact their board fabrication site for solder mask tolerances between and around signal pads.

IMPORTANT NOTICE

Texas Instruments Incorporated and its subsidiaries (TI) reserve the right to make corrections, enhancements, improvements and other changes to its semiconductor products and services per JESD46, latest issue, and to discontinue any product or service per JESD48, latest issue. Buyers should obtain the latest relevant information before placing orders and should verify that such information is current and complete. All semiconductor products (also referred to herein as "components") are sold subject to TI's terms and conditions of sale supplied at the time of order acknowledgment.

TI warrants performance of its components to the specifications applicable at the time of sale, in accordance with the warranty in TI's terms and conditions of sale of semiconductor products. Testing and other quality control techniques are used to the extent TI deems necessary to support this warranty. Except where mandated by applicable law, testing of all parameters of each component is not necessarily performed.

TI assumes no liability for applications assistance or the design of Buyers' products. Buyers are responsible for their products and applications using TI components. To minimize the risks associated with Buyers' products and applications, Buyers should provide adequate design and operating safeguards.

TI does not warrant or represent that any license, either express or implied, is granted under any patent right, copyright, mask work right, or other intellectual property right relating to any combination, machine, or process in which TI components or services are used. Information published by TI regarding third-party products or services does not constitute a license to use such products or services or a warranty or endorsement thereof. Use of such information may require a license from a third party under the patents or other intellectual property of the third party, or a license from TI under the patents or other intellectual property of TI.

Reproduction of significant portions of TI information in TI data books or data sheets is permissible only if reproduction is without alteration and is accompanied by all associated warranties, conditions, limitations, and notices. TI is not responsible or liable for such altered documentation. Information of third parties may be subject to additional restrictions.

Resale of TI components or services with statements different from or beyond the parameters stated by TI for that component or service voids all express and any implied warranties for the associated TI component or service and is an unfair and deceptive business practice. TI is not responsible or liable for any such statements.

Buyer acknowledges and agrees that it is solely responsible for compliance with all legal, regulatory and safety-related requirements concerning its products, and any use of TI components in its applications, notwithstanding any applications-related information or support that may be provided by TI. Buyer represents and agrees that it has all the necessary expertise to create and implement safeguards which anticipate dangerous consequences of failures, monitor failures and their consequences, lessen the likelihood of failures that might cause harm and take appropriate remedial actions. Buyer will fully indemnify TI and its representatives against any damages arising out of the use of any TI components in safety-critical applications.

In some cases, TI components may be promoted specifically to facilitate safety-related applications. With such components, TI's goal is to help enable customers to design and create their own end-product solutions that meet applicable functional safety standards and requirements. Nonetheless, such components are subject to these terms.

No TI components are authorized for use in FDA Class III (or similar life-critical medical equipment) unless authorized officers of the parties have executed a special agreement specifically governing such use.

Only those TI components which TI has specifically designated as military grade or "enhanced plastic" are designed and intended for use in military/aerospace applications or environments. Buyer acknowledges and agrees that any military or aerospace use of TI components which have **not** been so designated is solely at the Buyer's risk, and that Buyer is solely responsible for compliance with all legal and regulatory requirements in connection with such use.

TI has specifically designated certain components as meeting ISO/TS16949 requirements, mainly for automotive use. In any case of use of non-designated products, TI will not be responsible for any failure to meet ISO/TS16949.

Products

Audio	www.ti.com/audio
Amplifiers	amplifier.ti.com
Data Converters	dataconverter.ti.com
DLP® Products	www.dlp.com
DSP	dsp.ti.com
Clocks and Timers	www.ti.com/clocks
Interface	interface.ti.com
Logic	logic.ti.com
Power Mgmt	power.ti.com
Microcontrollers	microcontroller.ti.com
RFID	www.ti-rfid.com
OMAP Applications Processors	www.ti.com/omap
Wireless Connectivity	www.ti.com/wirelessconnectivity

Applications

Automotive and Transportation	www.ti.com/automotive
Communications and Telecom	www.ti.com/communications
Computers and Peripherals	www.ti.com/computers
Consumer Electronics	www.ti.com/consumer-apps
Energy and Lighting	www.ti.com/energy
Industrial	www.ti.com/industrial
Medical	www.ti.com/medical
Security	www.ti.com/security
Space, Avionics and Defense	www.ti.com/space-avionics-defense
Video and Imaging	www.ti.com/video

TI E2E Community

e2e.ti.com