

Analog Devices Welcomes Hittite Microwave Corporation

NO CONTENT ON THE ATTACHED DOCUMENT HAS CHANGED



THIS PAGE INTENTIONALLY LEFT BLANK

GaAs HEMT MMIC MEDIUM POWER AMPLIFIER, 81 - 86 GHz

Typical Applications

This HMC-APH634 is ideal for:

- Short Haul / High Capacity Links
- Test & Measurement
- E-Band Communication Systems

Features

- High Gain: 12 dB
- High P1dB: +19 dBm
- Bias Supply: +4V
- 50 Ohm Matched Input/Output
- Die Size: 2.57 x 1.70 x 0.05 mm

Functional Diagram

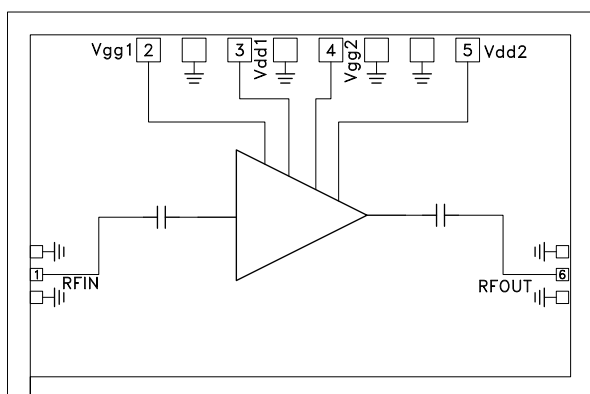

General Description

The HMC-APH634 is a two stage GaAs HEMT MMIC Medium Power Amplifier which operates between 81 and 86 GHz. The HMC-APH634 provides 12 dB of gain, and an output power of up to +20 dBm at 1 dB compression from a +4V supply. All bond pads and the die backside are Ti/Au metallized. The HMC-APH634 GaAs HEMT MMIC Medium Power Amplifier is compatible with conventional die attach methods, as well as thermocompression and thermosonic wire bonding, making it ideal for MCM and hybrid microcircuit applications. All data shown herein is measured with the chip in a 50 Ohm environment and contacted with RF probes.

Electrical Specifications, $T_A = +25^\circ\text{C}$, $V_{dd1}=V_{dd2} = 4\text{V}$, $I_{dd1}+I_{dd2} = 240\text{mA}$ [2]

Parameter	Min.	Typ.	Max.	Units
Frequency Range	81 - 86			GHz
Gain	7	12		dB
Input Return Loss		7		dB
Output Return Loss		8		dB
Output power for 1dB Compression (P1dB)		19		dBm
Supply Current (Idd1+Idd2)		240		mA

[1] Unless otherwise indicated, all measurements are from probed die.

[2] Adjust $V_{gg1}=V_{gg2}$ between -0.8V to +0.3V (typ. -0.1V) to achieve $I_{dd_{total}} = 240\text{mA}$

**GaAs HEMT MMIC MEDIUM POWER
 AMPLIFIER, 81 - 86 GHz**

Linear Gain vs. Frequency

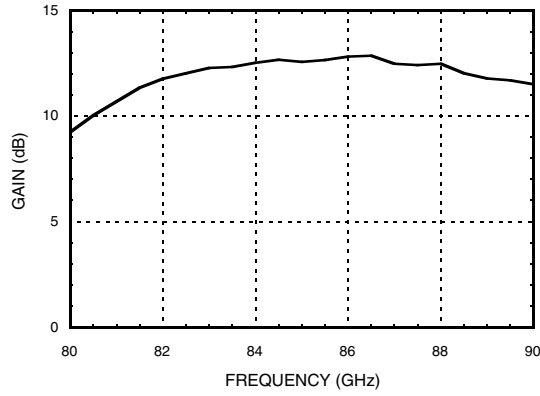

Fixtured Pout vs. Frequency

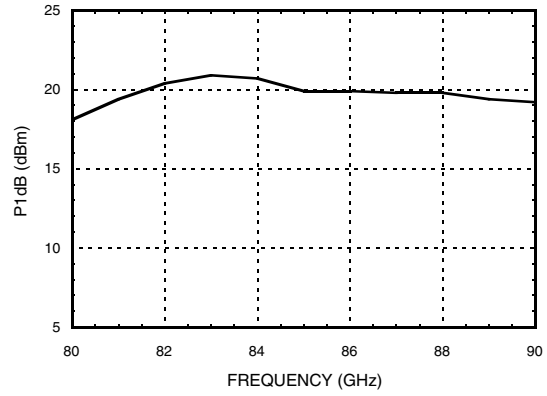

Input Return Loss vs. Frequency

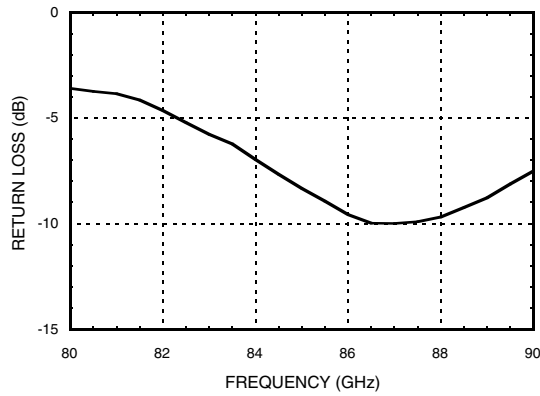

Output Return Loss vs. Frequency

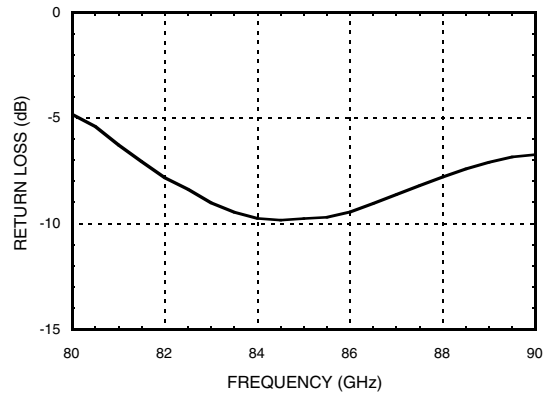

**GaAs HEMT MMIC MEDIUM POWER
 AMPLIFIER, 81 - 86 GHz**
Absolute Maximum Ratings

Drain Bias Voltage	+4.5V
Gate Bias Voltage	-0.8 to +0.3V
RF Input	13 dBm
Thermal Resistance (Channel to die bottom)	61.6 °C/W
Channel Temperature	180 °C
Storage Temperature	-65 °C to +150 °C
Operating Temperature	-55 °C to +85 °C
Drain Bias Current (I _{dd1})	100mA
Drain Bias Current (I _{dd2})	200mA



**ELECTROSTATIC SENSITIVE DEVICE
 OBSERVE HANDLING PRECAUTIONS**

**DO NOT EXPOSE PRODUCT TO
 CONDENSING MOISTURE WHILE
 UNDER OPERATION.**

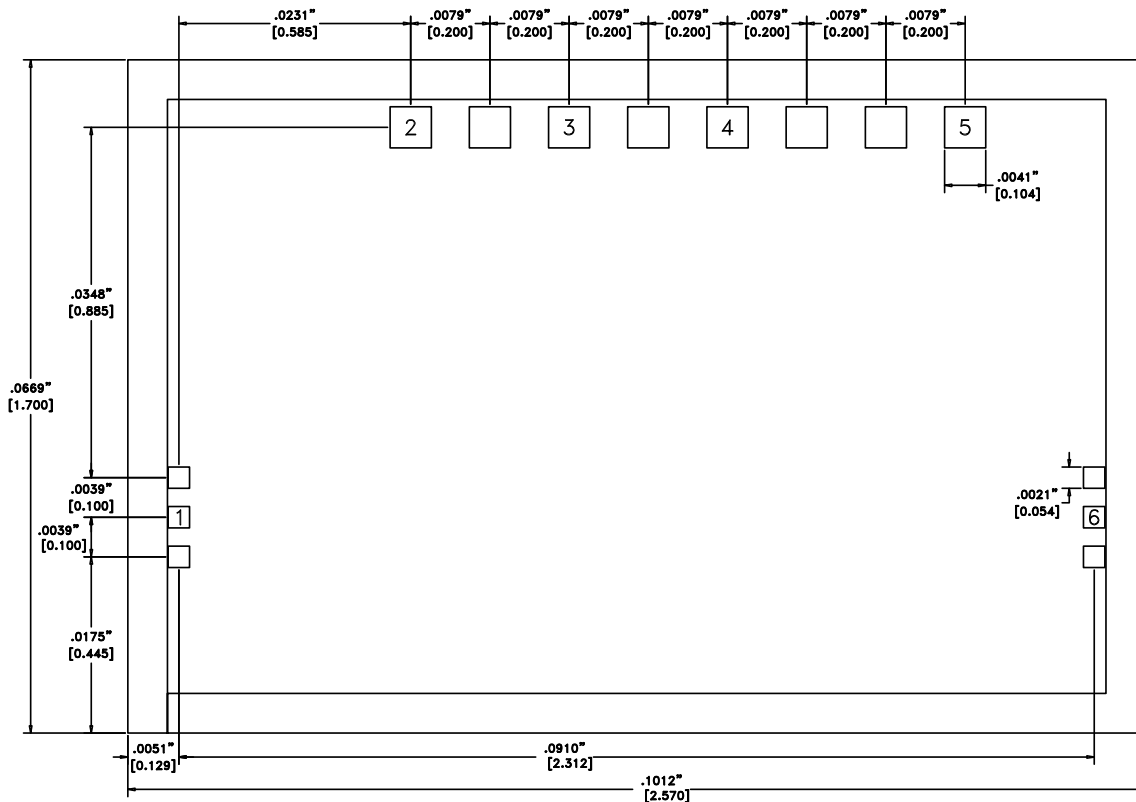
Outline Drawing

Die Packaging Information [1]

Standard	Alternate
GP-1 (Gel Pack)	[2]

[1] Refer to the "Packaging Information" section for die packaging dimensions.

[2] For alternate packaging information contact Hittite Microwave Corporation.



NOTES:

- ALL DIMENSIONS ARE IN INCHES [MM].
- BACKSIDE METALLIZATION: GOLD.
- BACKSIDE METAL IS GROUND.
- BOND PAD METALLIZATION: GOLD.
- CONNECTION NOT REQUIRED FOR UNLABELED BOND PADS.
- OVERALL DIE SIZE ±.002"

For price, delivery, and to place orders, please contact Hittite Microwave Corporation:
 2 Elizabeth Drive, Chelmsford, MA 01824 Phone: 978-250-3343 Fax: 978-250-3373
 Order On-line at www.hittite.com

GaAs HEMT MMIC MEDIUM POWER AMPLIFIER, 81 - 86 GHz

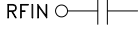
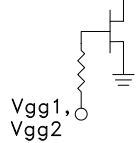
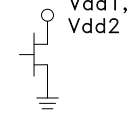
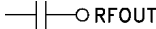
Pad Descriptions

Pad Number	Function	Description	Interface Schematic
1	RFIN	This pad is AC coupled and matched to 50 Ohms.	
2, 4	Vgg1, Vgg2	Gate control voltage for the amplifier, adjust to achieve I _{dd} total = 240mA ± 10mA. See assembly diagram for required external components.	
3, 5	Vdd1, Vdd2	Drain Supply Voltage for the amplifier. See assembly diagram for required external components.	
6	RFOUT	This pad is AC coupled and matched to 50 Ohms.	
Die Bottom	GND	Die bottom must be connected to RF/DC ground.	

GaAs HEMT MMIC MEDIUM POWER AMPLIFIER, 81 - 86 GHz

Assembly Diagram

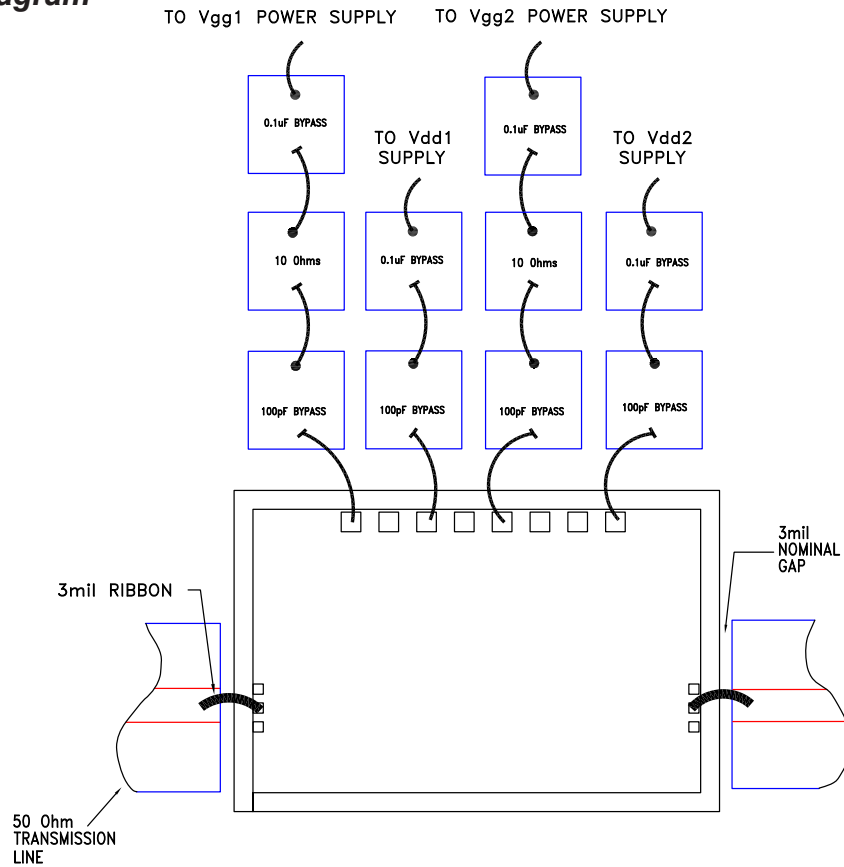

Note 1: Bypass caps should be 100 pF (approximately) ceramic (single-layer) placed no farther than 30 mils from the amplifier

Note 2: Best performance obtained from use of <10 mil (long) by 3 by 0.5mil ribbons on input and output.

Applications Circuit

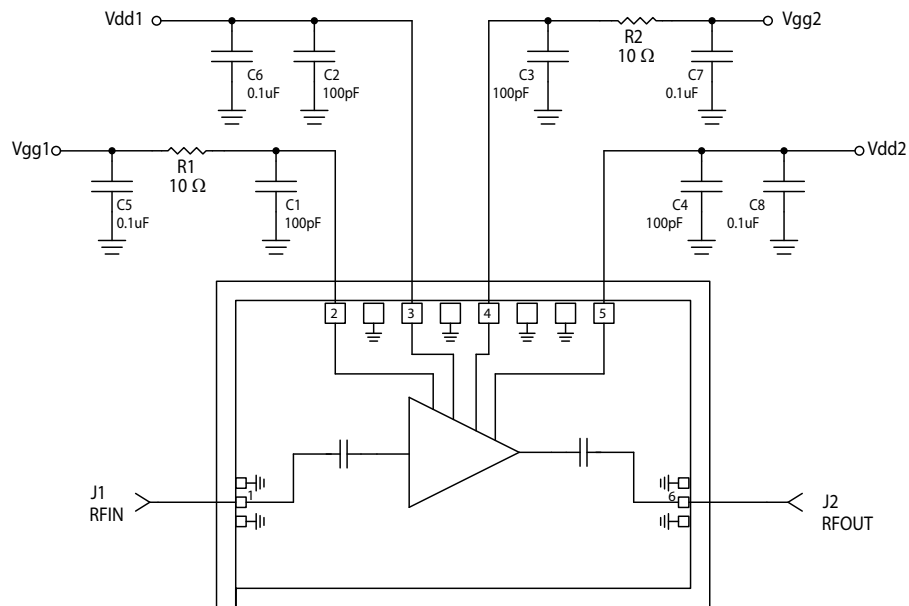

For price, delivery, and to place orders, please contact Hittite Microwave Corporation:
2 Elizabeth Drive, Chelmsford, MA 01824 Phone: 978-250-3343 Fax: 978-250-3373
Order On-line at www.hittite.com

**GaAs HEMT MMIC MEDIUM POWER
 AMPLIFIER, 81 - 86 GHz**
Mounting & Bonding Techniques for Millimeterwave GaAs MMICs

The die should be attached directly to the ground plane eutectically or with conductive epoxy (see HMC general Handling, Mounting, Bonding Note).

50 Ohm Microstrip transmission lines on 0.127mm (5 mil) thick alumina thin film substrates are recommended for bringing RF to and from the chip (Figure 1).

Microstrip substrates should be placed as close to the die as possible in order to minimize bond wire length. Typical die-to-substrate spacing is 0.076mm to 0.152 mm (3 to 6 mils).

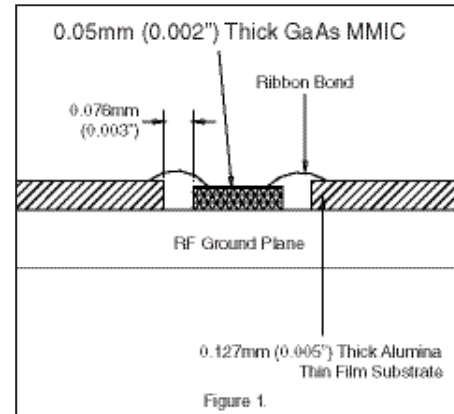
Handling Precautions

Follow these precautions to avoid permanent damage.

Storage: All bare die are placed in either Waffle or Gel based ESD protective containers, and then sealed in an ESD protective bag for shipment. Once the sealed ESD protective bag has been opened, all die should be stored in a dry nitrogen environment.

Cleanliness: Handle the chips in a clean environment. DO NOT attempt to clean the chip using liquid cleaning systems.

Static Sensitivity: Follow ESD precautions to protect against ESD strikes.

Transients: Suppress instrument and bias supply transients while bias is applied. Use shielded signal and bias cables to minimize inductive pick-up.

General Handling: Handle the chip along the edges with a vacuum collet or with a sharp pair of bent tweezers. The surface of the chip may have fragile air bridges and should not be touched with vacuum collet, tweezers, or fingers.

Mounting

The chip is back-metallized and can be die mounted with AuSn eutectic preforms or with electrically conductive epoxy. The mounting surface should be clean and flat.

Eutectic Die Attach: A 80/20 gold tin preform is recommended with a work surface temperature of 255 °C and a tool temperature of 265 °C. When hot 90/10 nitrogen/hydrogen gas is applied, tool tip temperature should be 290 °C. DO NOT expose the chip to a temperature greater than 320 °C for more than 20 seconds. No more than 3 seconds of scrubbing should be required for attachment.

Epoxy Die Attach: Apply a minimum amount of epoxy to the mounting surface so that a thin epoxy fillet is observed around the perimeter of the chip once it is placed into position. Cure epoxy per the manufacturer's schedule.

Wire Bonding

RF bonds made with 0.003" x 0.0005" ribbon are recommended. These bonds should be thermosonically bonded with a force of 40-60 grams. DC bonds of 0.001" (0.025 mm) diameter, thermosonically bonded, are recommended. Ball bonds should be made with a force of 40-50 grams and wedge bonds at 18-22 grams. All bonds should be made with a nominal stage temperature of 150 °C. A minimum amount of ultrasonic energy should be applied to achieve reliable bonds. All bonds should be as short as possible, less than 12 mils (0.31 mm).