

TPS2045A, TPS2046A, TPS2047A, TPS2048A
 TPS2055A, TPS2056A, TPS2057A, TPS2058A
CURRENT-LIMITED POWER-DISTRIBUTION SWITCHES

SLVS251A – SEPTEMBER 2000 – REVISED FEBRUARY 2001

- **80-mΩ High-Side MOSFET Switch**
- **250 mA Continuous Current Per Channel**
- **Independent Thermal and Short-Circuit Protection With Overcurrent Logic Output**
- **Operating Range . . . 2.7 V to 5.5 V**
- **CMOS- and TTL-Compatible Enable Inputs**
- **2.5-ms Typical Rise Time**
- **Undervoltage Lockout**
- **10 μA Maximum Standby Supply Current for Single and Dual (20 μA for Triple and Quad)**
- **Bidirectional Switch**
- **Ambient Temperature Range, 0°C to 85°C**
- **ESD Protection**

The TPS2045A through TPS2048A and TPS2055A through TPS2058A power-distribution switches are intended for applications where heavy capacitive loads and short circuits are likely to be encountered. These devices incorporate 80-mΩ N-channel MOSFET high-side power switches for power-distribution systems that require multiple power switches in a single package. Each switch is controlled by an independent logic enable input. Gate drive is provided by an internal charge pump designed to control the power-switch rise times and fall times to minimize current surges during switching. The charge pump requires no external components and allows operation from supplies as low as 2.7 V.

When the output load exceeds the current-limit threshold or a short is present, these devices limit the output current to a safe level by switching into a constant-current mode, pulling the overcurrent (\overline{OCx}) logic output low. When continuous heavy overloads and short circuits increase the power dissipation in the switch, causing the junction temperature to rise, a thermal protection circuit shuts off the switch to prevent damage. Recovery from a thermal shutdown is automatic once the device has cooled sufficiently. Internal circuitry ensures the switch remains off until valid input voltage is present. These power-distribution switches are designed to current limit at 0.5 A.

TPS2045A, TPS2055A
 D PACKAGE
 (TOP VIEW)

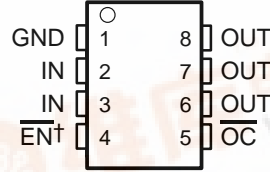

TPS2046A, TPS2056A
 D PACKAGE
 (TOP VIEW)

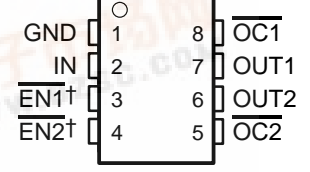

TPS2047A, TPS2057A
 D PACKAGE
 (TOP VIEW)

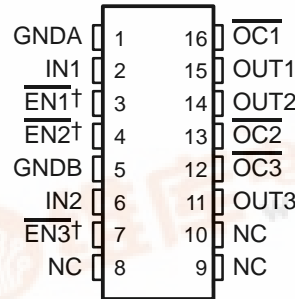

TPS2048A, TPS2058A
 D PACKAGE
 (TOP VIEW)

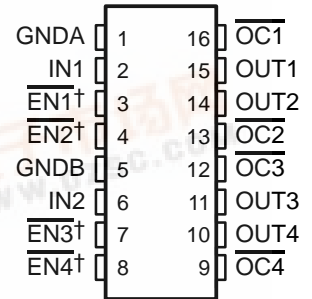

† All enable inputs are active high for the TPS205xA series.
 NC – No connect

GENERAL SWITCH CATALOG

<p>33 mΩ, single</p> <p>TPS201xA 0.2 A – 2 A TPS202x 0.2 A – 2 A TPS203x 0.2 A – 2 A</p>	<p>80 mΩ, dual</p> <p>TPS2042 500 mA TPS2052 500 mA TPS2046 250 mA TPS2056 250 mA</p>	<p>80 mΩ, dual</p> <p>TPS2080 500 mA TPS2081 500 mA TPS2082 500 mA TPS2090 250 mA TPS2091 250 mA TPS2092 250 mA</p>	<p>80 mΩ, triple</p> <p>TPS2043 500 mA TPS2053 500 mA TPS2047 250 mA TPS2057 250 mA</p>	<p>80 mΩ, quad</p> <p>TPS2044 500 mA TPS2054 500 mA TPS2048 250 mA TPS2058 250 mA</p>	<p>80 mΩ, quad</p> <p>TPS2085 500 mA TPS2086 500 mA TPS2087 500 mA TPS2095 250 mA TPS2096 250 mA TPS2097 250 mA</p>
<p>80 mΩ, single</p> <p>TPS2014 600 mA TPS2015 1 A TPS2041 500 mA TPS2051 500 mA TPS2045 250 mA TPS2055 250 mA</p>	<p>260 mΩ</p> <p>TPS2100/1 IN1 500 mA IN2 10 mA TPS2102/3/4/5 IN1 500 mA IN2 100 mA</p>				

Please be aware that an important notice concerning availability, standard warranty, and use in critical applications of Texas Instruments semiconductor products and disclaimers thereto appears at the end of this data sheet.



TPS2045A, TPS2046A, TPS2047A, TPS2048A
TPS2055A, TPS2056A, TPS2057A, TPS2058A
CURRENT-LIMITED POWER-DISTRIBUTION SWITCHES

SLVS251A – SEPTEMBER 2000 – REVISED FEBRUARY 2001

AVAILABLE OPTIONS

T _A	ENABLE	RECOMMENDED MAXIMUM CONTINUOUS LOAD CURRENT (A)	TYPICAL SHORT-CIRCUIT CURRENT LIMIT AT 25°C (A)	NUMBER OF SWITCHES	PACKAGED DEVICES
					SOIC (D)†
0°C to 85°C	Active low	0.25	0.5	Single	TPS2045AD
	Active high				TPS2055AD
	Active low			Dual	TPS2046AD
	Active high				TPS2056AD
	Active low			Triple	TPS2047AD
	Active high				TPS2057AD
	Active low			Quad	TPS2048AD
	Active high				TPS2058AD

† The D package is available taped and reeled. Add an R suffix to device type (e.g., TPS2045ADR)

**TPS2045A, TPS2046A, TPS2047A, TPS2048A
 TPS2055A, TPS2056A, TPS2057A, TPS2058A
 CURRENT-LIMITED POWER-DISTRIBUTION SWITCHES**
 SLVS251A – SEPTEMBER 2000 – REVISED FEBRUARY 2001

functional block diagrams

TPS2045A

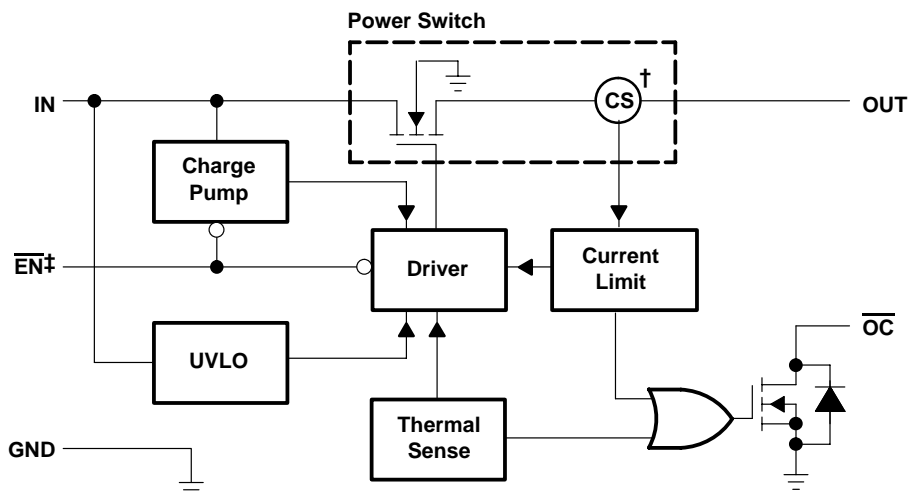

† Current sense
 ‡ Active high for TPS205xA series

TPS2046A

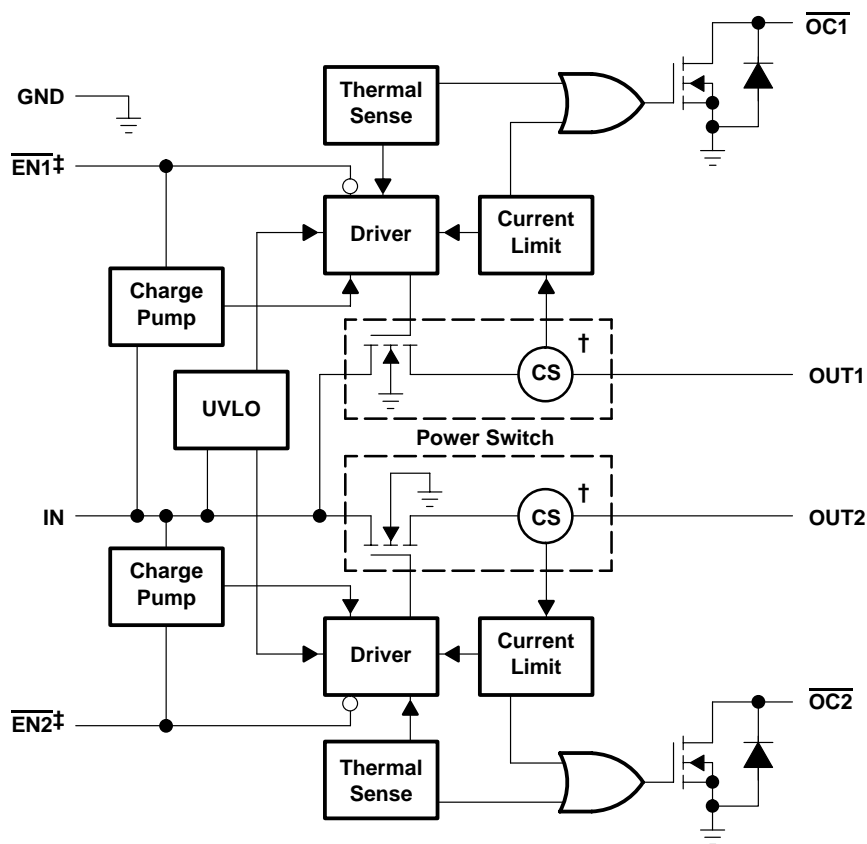

† Current sense
 ‡ Active high for TPS205xA series

TPS2045A, TPS2046A, TPS2047A, TPS2048A
TPS2055A, TPS2056A, TPS2057A, TPS2058A
CURRENT-LIMITED POWER-DISTRIBUTION SWITCHES

SLVS251A – SEPTEMBER 2000 – REVISED FEBRUARY 2001

functional block diagrams

TPS2047A

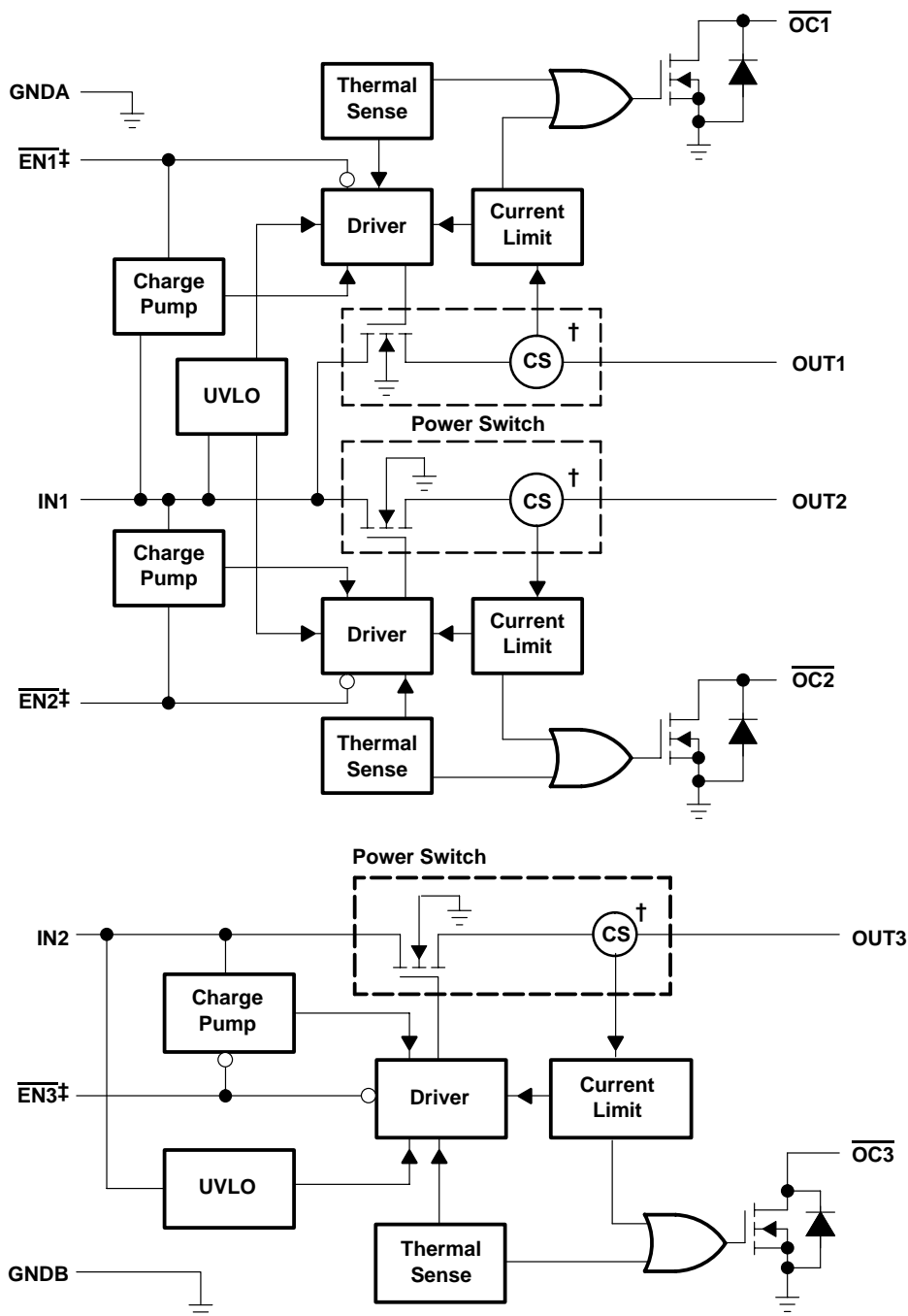

† Current sense
 ‡ Active high for TPS205xA series

TPS2045A, TPS2046A, TPS2047A, TPS2048A
 TPS2055A, TPS2056A, TPS2057A, TPS2058A
CURRENT-LIMITED POWER-DISTRIBUTION SWITCHES
 SLVS251A – SEPTEMBER 2000 – REVISED FEBRUARY 2001

functional block diagrams

TPS2048A

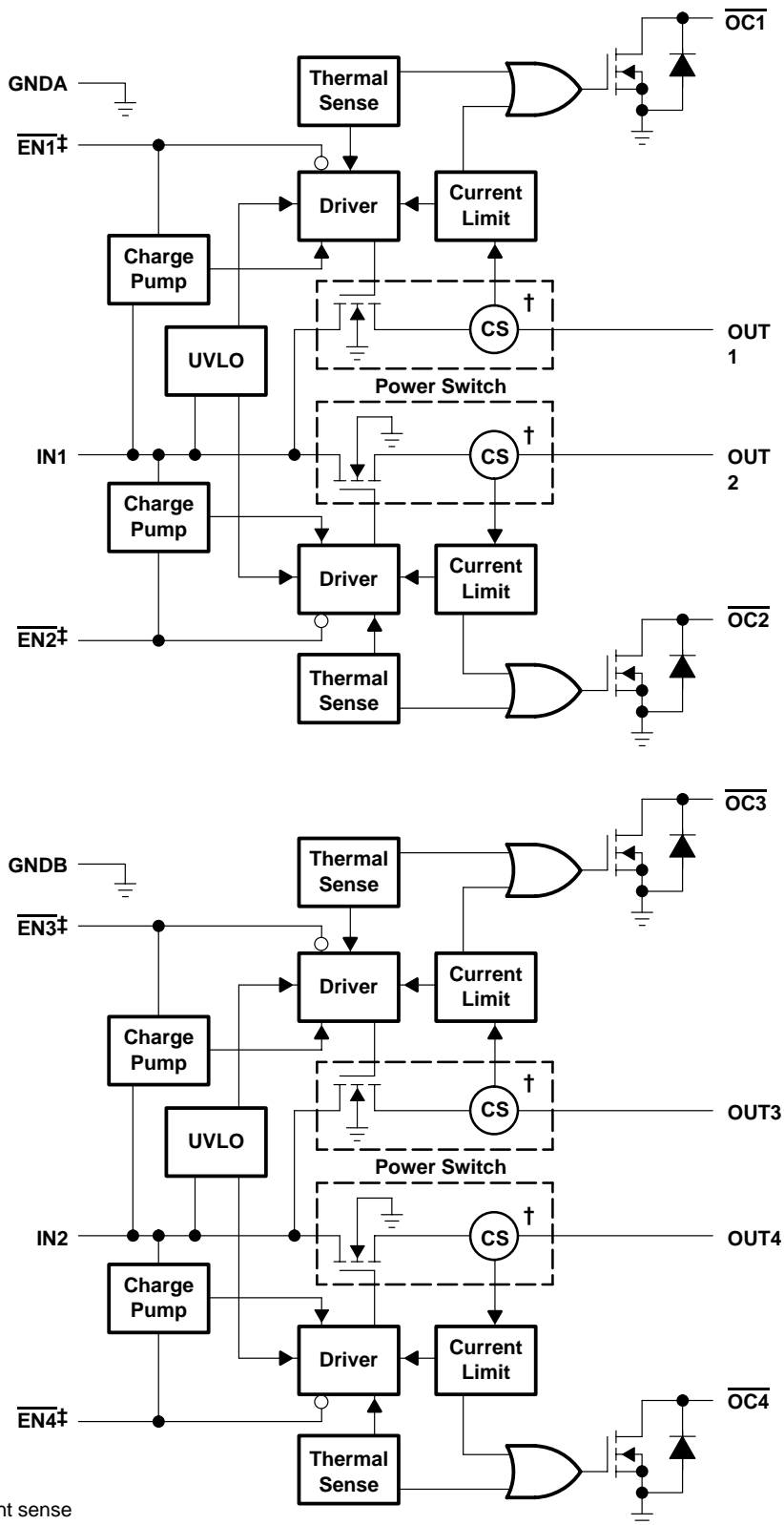

† Current sense
 ‡ Active high for TPS205xA series

**TPS2045A, TPS2046A, TPS2047A, TPS2048A
 TPS2055A, TPS2056A, TPS2057A, TPS2058A
 CURRENT-LIMITED POWER-DISTRIBUTION SWITCHES**

SLVS251A – SEPTEMBER 2000 – REVISED FEBRUARY 2001

Terminal Functions

TPS2045A and TPS2055A

NAME	TERMINAL NO.		I/O	DESCRIPTION
	TPS2045A	TPS2055A		
	EN	4		
EN	–	4	I	Enable input. Logic high turns on power switch.
GND	1	1	I	Ground
IN	2, 3	2, 3	I	Input voltage
OC	5	5	O	Overcurrent. Open drain output active low
OUT	6, 7, 8	6, 7, 8	O	Power-switch output

TPS2046A and TPS2056A

NAME	TERMINAL NO.		I/O	DESCRIPTION
	TPS2046A	TPS2056A		
	EN1	3		
EN2	4	–	I	Enable input. Logic low turns on power switch, IN-OUT2.
EN1	–	3	I	Enable input. Logic high turns on power switch, IN-OUT1.
EN2	–	4	I	Enable input. Logic high turns on power switch, IN-OUT2.
GND	1	1	I	Ground
IN	2	2	I	Input voltage
OC1	8	8	O	Overcurrent. Open drain output active low, for power switch, IN-OUT1
OC2	5	5	O	Overcurrent. Open drain output active low, for power switch, IN-OUT2
OUT1	7	7	O	Power-switch output
OUT2	6	6	O	Power-switch output

TPS2045A, TPS2046A, TPS2047A, TPS2048A
TPS2055A, TPS2056A, TPS2057A, TPS2058A
CURRENT-LIMITED POWER-DISTRIBUTION SWITCHES
SLVS251A – SEPTEMBER 2000 – REVISED FEBRUARY 2001

Terminal Functions (Continued)

TPS2047A and TPS2057A

NAME	TERMINAL NO.		I/O	DESCRIPTION
	TPS2047A	TPS2057A		
	EN1	3		
EN2	4	–	I	Enable input, logic low turns on power switch, IN1-OUT2.
EN3	7	–	I	Enable input, logic low turns on power switch, IN2-OUT3.
EN1	–	3	I	Enable input, logic high turns on power switch, IN1-OUT1.
EN2	–	4	I	Enable input, logic high turns on power switch, IN1-OUT2.
EN3	–	7	I	Enable input, logic high turns on power switch, IN2-OUT3.
GND A	1	1		Ground for IN1 switch and circuitry.
GND B	5	5		Ground for IN2 switch and circuitry.
IN1	2	2	I	Input voltage
IN2	6	6	I	Input voltage
NC	8, 9, 10	8, 9, 10		No connection
OC1	16	16	O	Overcurrent, open drain output active low, IN1-OUT1
OC2	13	13	O	Overcurrent, open drain output active low, IN1-OUT2
OC3	12	12	O	Overcurrent, open drain output active low, IN2-OUT3
OUT1	15	15	O	Power-switch output, IN1-OUT1
OUT2	14	14	O	Power-switch output, IN1-OUT2
OUT3	11	11	O	Power-switch output, IN2-OUT3

TPS2048A and TPS2058A

NAME	TERMINAL NO.		I/O	DESCRIPTION
	TPS2048A	TPS2058A		
	EN1	3		
EN2	4	–	I	Enable input. Logic low turns on power switch, IN1-OUT2.
EN3	7	–	I	Enable input. Logic low turns on power switch, IN2-OUT3.
EN4	8	–	I	Enable input. Logic low turns on power switch, IN2-OUT4.
EN1	–	3	I	Enable input. Logic high turns on power switch, IN1-OUT1.
EN2	–	4	I	Enable input. Logic high turns on power switch, IN1-OUT2.
EN3	–	7	I	Enable input. Logic high turns on power switch, IN2-OUT3.
EN4	–	8	I	Enable input. Logic high turns on power switch, IN2-OUT4.
GND A	1	1		Ground for IN1 switch and circuitry.
GND B	5	5		Ground for IN2 switch and circuitry.
IN1	2	2	I	Input voltage
IN2	6	6	I	Input voltage
OC1	16	16	O	Overcurrent. Open drain output active low, IN1-OUT1
OC2	13	13	O	Overcurrent. Open drain output active low, IN1-OUT2
OC3	12	12	O	Overcurrent. Open drain output active low, IN2-OUT3
OC4	9	9	O	Overcurrent. Open drain output active low, IN2-OUT4
OUT1	15	15	O	Power-switch output, IN1-OUT1
OUT2	14	14	O	Power-switch output, IN1-OUT2
OUT3	11	11	O	Power-switch output, IN2-OUT3
OUT4	10	10	O	Power-switch output, IN2-OUT4

TPS2045A, TPS2046A, TPS2047A, TPS2048A TPS2055A, TPS2056A, TPS2057A, TPS2058A CURRENT-LIMITED POWER-DISTRIBUTION SWITCHES

SLVS251A – SEPTEMBER 2000 – REVISED FEBRUARY 2001

detailed description

power switch

The power switch is an N-channel MOSFET with a maximum on-state resistance of 135 m Ω ($V_{I(IN)} = 5$ V). Configured as a high-side switch, the power switch prevents current flow from OUT to IN and IN to OUT when disabled. The power switch supplies a minimum of 250 mA per switch.

charge pump

An internal charge pump supplies power to the driver circuit and provides the necessary voltage to pull the gate of the MOSFET above the source. The charge pump operates from input voltages as low as 2.7 V and requires very little supply current.

driver

The driver controls the gate voltage of the power switch. To limit large current surges and reduce the associated electromagnetic interference (EMI) produced, the driver incorporates circuitry that controls the rise times and fall times of the output voltage. The rise and fall times are typically in the 2-ms to 4-ms range.

enable (\overline{ENx} , ENx)

The logic enable disables the power switch and the bias for the charge pump, driver, and other circuitry to reduce the supply current. The supply current is reduced to less than 10 μ A on the single and dual devices (20 μ A on the triple and quad devices) when a logic high is present on \overline{ENx} (TPS204xA \dagger) or a logic low is present on ENx (TPS205xA \dagger). A logic zero input on \overline{ENx} or a logic high on ENx restores bias to the drive and control circuits and turns the power on. The enable input is compatible with both TTL and CMOS logic levels.

overcurrent (\overline{OCx})

The \overline{OCx} open-drain output is asserted (active low) when an overcurrent or overtemperature condition is encountered. The output will remain asserted until the overcurrent or overtemperature condition is removed.

current sense

A sense FET monitors the current supplied to the load. The sense FET measures current more efficiently than conventional resistance methods. When an overload or short circuit is encountered, the current-sense circuitry sends a control signal to the driver. The driver in turn reduces the gate voltage and drives the power FET into its saturation region, which switches the output into a constant-current mode and holds the current constant while varying the voltage on the load.

thermal sense

The TPS204xA and TPS205xA implement a dual-threshold thermal trip to allow fully independent operation of the power distribution switches. In an overcurrent or short-circuit condition the junction temperature rises. When the die temperature rises to approximately 140°C, the internal thermal sense circuitry checks to determine which power switch is in an overcurrent condition and turns off that switch, thus isolating the fault without interrupting operation of the adjacent power switch. Hysteresis is built into the thermal sense, and after the device has cooled approximately 20 degrees, the switch turns back on. The switch continues to cycle off and on until the fault is removed. The (\overline{OCx}) open-drain output is asserted (active low) when overtemperature or overcurrent occurs.

undervoltage lockout

A voltage sense circuit monitors the input voltage. When the input voltage is below approximately 2 V, a control signal turns off the power switch.

\dagger Product series designations TPS204x and TPS205x refer to devices presented in this data sheet and not necessarily to other TI devices numbered in this sequence.

TPS2045A, TPS2046A, TPS2047A, TPS2048A
TPS2055A, TPS2056A, TPS2057A, TPS2058A
CURRENT-LIMITED POWER-DISTRIBUTION SWITCHES

SLVS251A – SEPTEMBER 2000 – REVISED FEBRUARY 2001

absolute maximum ratings over operating free-air temperature range (unless otherwise noted)†

Input voltage range, $V_{I(IN)}$ (see Note 1)	–0.3 V to 6 V
Output voltage range, $V_{O(OUT)}$ (see Note 1)	–0.3 V to $V_{I(IN)} + 0.3$ V
Input voltage range, $V_{I(ENx)}$ or $V_{I(EN)}$	–0.3 V to 6 V
Continuous output current, $I_{O(OUT)}$	internally limited
Continuous total power dissipation	See Dissipation Rating Table
Operating virtual junction temperature range, T_J	0°C to 125°C
Storage temperature range, T_{stg}	–65°C to 150°C
Lead temperature soldering 1,6 mm (1/16 inch) from case for 10 seconds	260°C
Electrostatic discharge (ESD) protection: Human body model MIL-STD-883C	2 kV
Machine model	0.2 kV

† Stresses beyond those listed under “absolute maximum ratings” may cause permanent damage to the device. These are stress ratings only, and functional operation of the device at these or any other conditions beyond those indicated under “recommended operating conditions” is not implied. Exposure to absolute-maximum-rated conditions for extended periods may affect device reliability.

NOTE 1: All voltages are with respect to GND.

DISSIPATION RATING TABLE

PACKAGE	$T_A \leq 25^\circ\text{C}$ POWER RATING	DERATING FACTOR ABOVE $T_A = 25^\circ\text{C}$	$T_A = 70^\circ\text{C}$ POWER RATING	$T_A = 85^\circ\text{C}$ POWER RATING
D–8	725 mW	5.9 mW/°C	464 mW	377 mW
D–16	1123 mW	9 mW/°C	719 mW	584 mW

recommended operating conditions

	MIN	MAX	UNIT
Input voltage, $V_{I(IN)}$	2.7	5.5	V
Input voltage, $V_{I(EN)}$ or $V_{I(EN)}$	0	5.5	V
Continuous output current, $I_{O(OUT)}$ (per switch)	0	250	mA
Operating virtual junction temperature, T_J	0	125	°C

TPS2045A, TPS2046A, TPS2047A, TPS2048A
TPS2055A, TPS2056A, TPS2057A, TPS2058A
CURRENT-LIMITED POWER-DISTRIBUTION SWITCHES

SLVS251A – SEPTEMBER 2000 – REVISED FEBRUARY 2001

electrical characteristics over recommended operating junction temperature range, $V_{I(IN)} = 5.5\text{ V}$, $I_O = \text{rated current}$, $V_{I(EN)} = 0\text{ V}$, $V_{I(EN)} = V_{I(IN)}$ (unless otherwise noted)

power switch

PARAMETER		TEST CONDITIONST	TPS204xA			TPS205xA			UNIT
			MIN	TYP	MAX	MIN	TYP	MAX	
$r_{DS(on)}$	Static drain-source on-state resistance, 5-V operation	$V_{I(IN)} = 5\text{ V}$, $T_J = 25^\circ\text{C}$, $I_O = 0.25\text{ A}$	80	100		80	100	m Ω	
		$V_{I(IN)} = 5\text{ V}$, $T_J = 85^\circ\text{C}$, $I_O = 0.25\text{ A}$	90	120		90	120		
		$V_{I(IN)} = 5\text{ V}$, $T_J = 125^\circ\text{C}$, $I_O = 0.25\text{ A}$	100	135		100	135		
	Static drain-source on-state resistance, 3.3-V operation	$V_{I(IN)} = 3.3\text{ V}$, $T_J = 25^\circ\text{C}$, $I_O = 0.25\text{ A}$	90	125		90	125		
		$V_{I(IN)} = 3.3\text{ V}$, $T_J = 85^\circ\text{C}$, $I_O = 0.25\text{ A}$	110	145		110	145		
		$V_{I(IN)} = 3.3\text{ V}$, $T_J = 125^\circ\text{C}$, $I_O = 0.25\text{ A}$	120	160		120	160		
t_r	Rise time, output	$V_{I(IN)} = 5.5\text{ V}$, $T_J = 25^\circ\text{C}$, $C_L = 1\text{ }\mu\text{F}$, $R_L = 20\text{ }\Omega$	2.5			2.5		ms	
		$V_{I(IN)} = 2.7\text{ V}$, $T_J = 25^\circ\text{C}$, $C_L = 1\text{ }\mu\text{F}$, $R_L = 20\text{ }\Omega$	3			3			
t_f	Fall time, output	$V_{I(IN)} = 5.5\text{ V}$, $T_J = 25^\circ\text{C}$, $C_L = 1\text{ }\mu\text{F}$, $R_L = 20\text{ }\Omega$	4.4			4.4		ms	
		$V_{I(IN)} = 2.7\text{ V}$, $T_J = 25^\circ\text{C}$, $C_L = 1\text{ }\mu\text{F}$, $R_L = 20\text{ }\Omega$	2.5			2.5			

† Pulse-testing techniques maintain junction temperature close to ambient temperature; thermal effects must be taken into account separately.

enable input \overline{ENx} or ENx

PARAMETER		TEST CONDITIONS	TPS204xA			TPS205xA			UNIT
			MIN	TYP	MAX	MIN	TYP	MAX	
V_{IH}	High-level input voltage	$2.7\text{ V} \leq V_{I(IN)} \leq 5.5\text{ V}$	2			2			V
V_{IL}	Low-level input voltage	$4.5\text{ V} \leq V_{I(IN)} \leq 5.5\text{ V}$			0.8			0.8	V
		$2.7\text{ V} \leq V_{I(IN)} \leq 4.5\text{ V}$			0.4			0.4	
I_I	Input current	TPS204xA $V_{I(ENx)} = 0\text{ V}$ or $V_{I(ENx)} = V_{I(IN)}$	-0.5		0.5				μA
		TPS205xA $V_{I(ENx)} = V_{I(IN)}$ or $V_{I(ENx)} = 0\text{ V}$				-0.5		0.5	
t_{on}	Turnon time	$C_L = 100\text{ }\mu\text{F}$, $R_L = 20\text{ }\Omega$			20			20	ms
t_{off}	Turnoff time	$C_L = 100\text{ }\mu\text{F}$, $R_L = 20\text{ }\Omega$			40			40	ms

current limit

PARAMETER		TEST CONDITIONST	TPS204xA			TPS205xA			UNIT
			MIN	TYP	MAX	MIN	TYP	MAX	
I_{OS}	Short-circuit output current	$V_{I(IN)} = 5\text{ V}$, OUT connected to GND, Device enabled into short circuit	0.3	0.5	0.7	0.3	0.5	0.7	A

† Pulse-testing techniques maintain junction temperature close to ambient temperature; thermal effects must be taken into account separately.

TPS2045A, TPS2046A, TPS2047A, TPS2048A
TPS2055A, TPS2056A, TPS2057A, TPS2058A
CURRENT-LIMITED POWER-DISTRIBUTION SWITCHES

SLVS251A – SEPTEMBER 2000 – REVISED FEBRUARY 2001

electrical characteristics over recommended operating junction temperature range, $V_{I(IN)} = 5.5\text{ V}$, $I_O = \text{rated current}$, $V_{I(EN)} = 0\text{ V}$, $V_{I(EN)} = V_{I(IN)}$ (unless otherwise noted) (continued)

supply current (TPS2045A, TPS2055A)

PARAMETER	TEST CONDITIONS			TPS2045A			TPS2055A			UNIT
				MIN	TYP	MAX	MIN	TYP	MAX	
Supply current, low-level output	No Load on OUT	$\overline{V_{I(EN)}} = V_{I(IN)}$	$T_J = 25^\circ\text{C}$	0.025	1				μA	
			$-40^\circ\text{C} \leq T_J \leq 125^\circ\text{C}$			10				
		$V_{I(EN)} = 0\text{ V}$	$T_J = 25^\circ\text{C}$			0.025	1			
			$-40^\circ\text{C} \leq T_J \leq 125^\circ\text{C}$					10		
Supply current, high-level output	No Load on OUT	$\overline{V_{I(EN)}} = 0\text{ V}$	$T_J = 25^\circ\text{C}$	85	110			μA		
			$-40^\circ\text{C} \leq T_J \leq 125^\circ\text{C}$			100				
		$V_{I(EN)} = V_{I(IN)}$	$T_J = 25^\circ\text{C}$			85	110			
			$-40^\circ\text{C} \leq T_J \leq 125^\circ\text{C}$			100				
Leakage current	OUT connected to ground	$\overline{V_{I(EN)}} = V_{I(IN)}$	$-40^\circ\text{C} \leq T_J \leq 125^\circ\text{C}$	100				μA		
		$V_{I(EN)} = 0\text{ V}$	$-40^\circ\text{C} \leq T_J \leq 125^\circ\text{C}$			100		μA		
Reverse leakage current	IN = High impedance	$\overline{V_{I(EN)}} = 0\text{ V}$	$T_J = 25^\circ\text{C}$	0.3				μA		
		$V_{I(EN)} = V_{I(IN)}$				0.3		μA		

supply current (TPS2046A, TPS2056A)

PARAMETER	TEST CONDITIONS			TPS2046A			TPS2056A			UNIT
				MIN	TYP	MAX	MIN	TYP	MAX	
Supply current, low-level output	No Load on OUT	$\overline{V_{I(ENx)}} = V_{I(IN)}$	$T_J = 25^\circ\text{C}$	0.025	1				μA	
			$-40^\circ\text{C} \leq T_J \leq 125^\circ\text{C}$			10				
		$V_{I(ENx)} = 0\text{ V}$	$T_J = 25^\circ\text{C}$			0.025	1			
			$-40^\circ\text{C} \leq T_J \leq 125^\circ\text{C}$					10		
Supply current, high-level output	No Load on OUT	$\overline{V_{I(ENx)}} = 0\text{ V}$	$T_J = 25^\circ\text{C}$	85	110			μA		
			$-40^\circ\text{C} \leq T_J \leq 125^\circ\text{C}$			100				
		$V_{I(ENx)} = V_{I(IN)}$	$T_J = 25^\circ\text{C}$			85	110			
			$-40^\circ\text{C} \leq T_J \leq 125^\circ\text{C}$			100				
Leakage current	OUT connected to ground	$\overline{V_{I(ENx)}} = V_{I(IN)}$	$-40^\circ\text{C} \leq T_J \leq 125^\circ\text{C}$	100				μA		
		$V_{I(ENx)} = 0\text{ V}$	$-40^\circ\text{C} \leq T_J \leq 125^\circ\text{C}$			100		μA		
Reverse leakage current	IN = high impedance	$\overline{V_{I(EN)}} = 0\text{ V}$	$T_J = 25^\circ\text{C}$	0.3				μA		
		$V_{I(EN)} = V_{I(IN)}$				0.3		μA		

**TPS2045A, TPS2046A, TPS2047A, TPS2048A
 TPS2055A, TPS2056A, TPS2057A, TPS2058A
 CURRENT-LIMITED POWER-DISTRIBUTION SWITCHES**

SLVS251A – SEPTEMBER 2000 – REVISED FEBRUARY 2001

electrical characteristics over recommended operating junction temperature range, $V_{I(IN)} = 5.5\text{ V}$, $I_O = \text{rated current}$, $V_{I(EN)} = 0\text{ V}$, $V_{I(EN)} = V_{I(IN)}$ (unless otherwise noted) (continued)

supply current (TPS2047A, TPS2057A)

PARAMETER	TEST CONDITIONS			TPS2047A			TPS2057A			UNIT
				MIN	TYP	MAX	MIN	TYP	MAX	
Supply current, low-level output	No load on OUTx	$\overline{V_{I(ENx)}} = V_{I(INx)}$	$T_J = 25^\circ\text{C}$	0.05	2				μA	
			$-40^\circ\text{C} \leq T_J \leq 125^\circ\text{C}$		20					
		$V_{I(ENx)} = 0\text{ V}$	$T_J = 25^\circ\text{C}$			0.05	2			
			$-40^\circ\text{C} \leq T_J \leq 125^\circ\text{C}$				20			
Supply current, high-level output	No load on OUTx	$\overline{V_{I(ENx)}} = 0\text{ V}$	$T_J = 25^\circ\text{C}$	160	200			μA		
			$-40^\circ\text{C} \leq T_J \leq 125^\circ\text{C}$		200					
		$V_{I(ENx)} = V_{I(INx)}$	$T_J = 25^\circ\text{C}$			160	200			
			$-40^\circ\text{C} \leq T_J \leq 125^\circ\text{C}$			200				
Leakage current	OUTx connected to ground	$\overline{V_{I(ENx)}} = V_{I(INx)}$	$-40^\circ\text{C} \leq T_J \leq 125^\circ\text{C}$	200				μA		
		$V_{I(ENx)} = 0\text{ V}$	$-40^\circ\text{C} \leq T_J \leq 125^\circ\text{C}$			200		μA		
Reverse leakage current	IN = high impedance	$V_{I(ENx)} = 0\text{ V}$	$T_J = 25^\circ\text{C}$	0.3				μA		
		$V_{I(ENx)} = V_{I(IN)}$				0.3		μA		

supply current (TPS2048A, TPS2058A)

PARAMETER	TEST CONDITIONS			TPS2048A			TPS2058A			UNIT
				MIN	TYP	MAX	MIN	TYP	MAX	
Supply current, low-level output	No Load on OUTx	$\overline{V_{I(ENx)}} = V_{I(INx)}$	$T_J = 25^\circ\text{C}$	0.05	2			μA		
			$-40^\circ\text{C} \leq T_J \leq 125^\circ\text{C}$		20					
		$V_{I(ENx)} = 0\text{ V}$	$T_J = 25^\circ\text{C}$			0.05	2			
			$-40^\circ\text{C} \leq T_J \leq 125^\circ\text{C}$				20			
Supply current, high-level output	No Load on OUTx	$\overline{V_{I(ENx)}} = 0\text{ V}$	$T_J = 25^\circ\text{C}$	170	220			μA		
			$-40^\circ\text{C} \leq T_J \leq 125^\circ\text{C}$		200					
		$V_{I(ENx)} = V_{I(INx)}$	$T_J = 25^\circ\text{C}$			170	220			
			$-40^\circ\text{C} \leq T_J \leq 125^\circ\text{C}$			200				
Leakage current	OUTx connected to ground	$\overline{V_{I(ENx)}} = V_{I(INx)}$	$-40^\circ\text{C} \leq T_J \leq 125^\circ\text{C}$	200				μA		
		$V_{I(ENx)} = 0\text{ V}$	$-40^\circ\text{C} \leq T_J \leq 125^\circ\text{C}$			200		μA		
Reverse leakage current	IN = high impedance	$V_{I(EN)} = 0\text{ V}$	$T_J = 25^\circ\text{C}$	0.3				μA		
		$V_{I(EN)} = V_{I(IN)}$				0.3		μA		

undervoltage lockout

PARAMETER	TEST CONDITIONS	TPS204xA			TPS205xA			UNIT
		MIN	TYP	MAX	MIN	TYP	MAX	
Low-level input voltage		2		2.5	2		2.5	V
Hysteresis	$T_J = 25^\circ\text{C}$		100			100		mV

overcurrent \overline{OC}

PARAMETER	TEST CONDITIONS	TPS204xA			TPS205xA			UNIT
		MIN	TYP	MAX	MIN	TYP	MAX	
Sink current [†]	$V_O = 5\text{ V}$			10			10	mA
Output low voltage	$I_O = 5\text{ V}$, $V_{OL(OC)}$			0.5			0.5	V
Off-state current [†]	$V_O = 5\text{ V}$, $V_O = 3.3\text{ V}$			1			1	μA

[†] Specified by design, not production tested.

TPS2045A, TPS2046A, TPS2047A, TPS2048A
 TPS2055A, TPS2056A, TPS2057A, TPS2058A
CURRENT-LIMITED POWER-DISTRIBUTION SWITCHES
 SLVS251A – SEPTEMBER 2000 – REVISED FEBRUARY 2001

PARAMETER MEASUREMENT INFORMATION

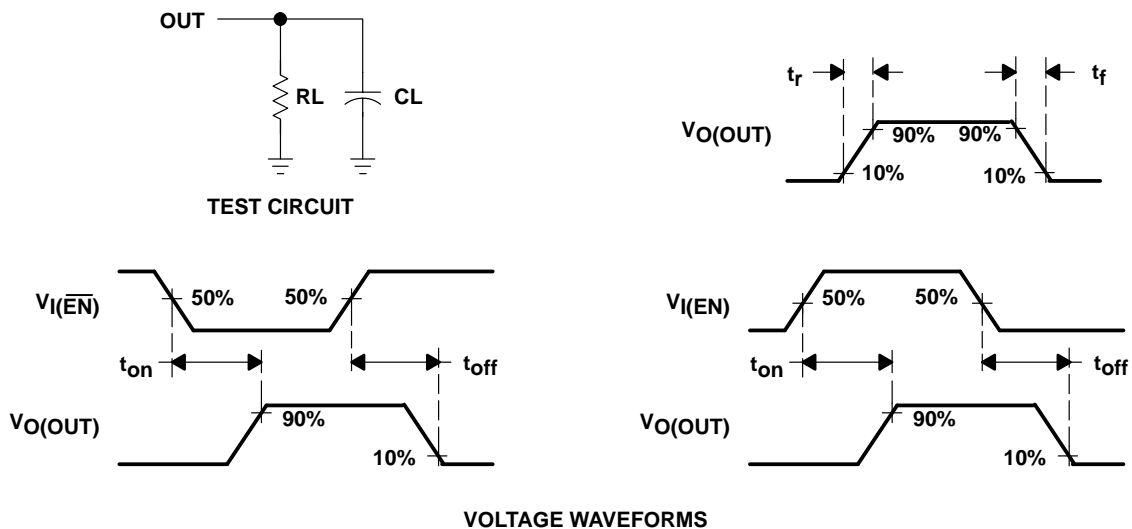

Figure 1. Test Circuit and Voltage Waveforms

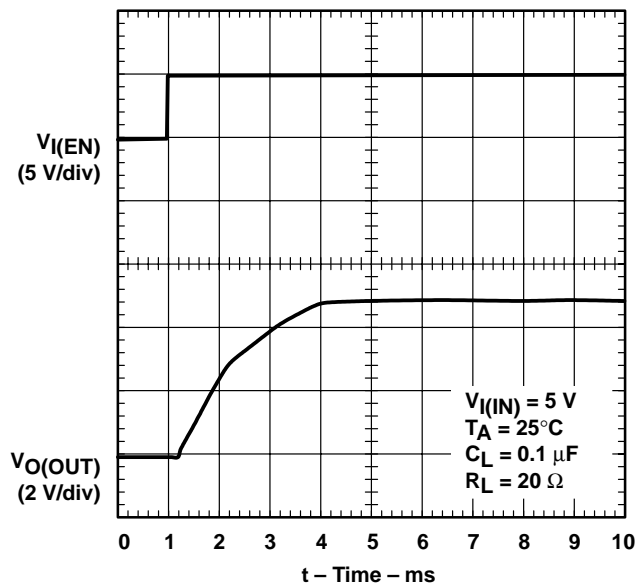

Figure 2. Turnon Delay and Rise Time
 With 0.1- μF Load

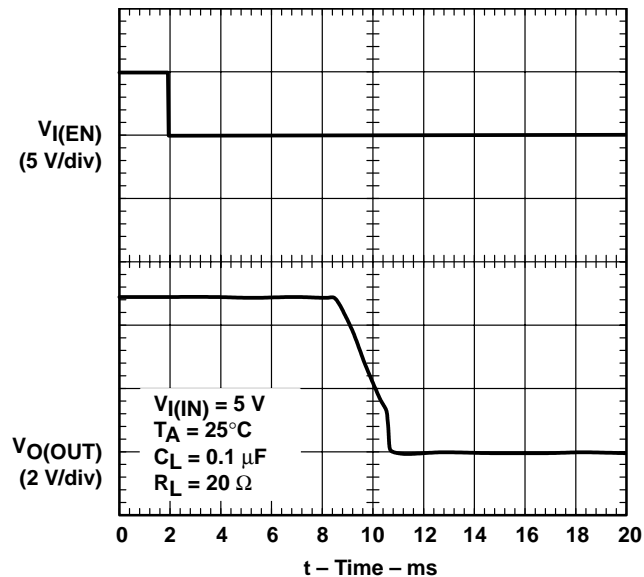

Figure 3. Turnoff Delay and Fall Time
 With 0.1- μF Load

**TPS2045A, TPS2046A, TPS2047A, TPS2048A
 TPS2055A, TPS2056A, TPS2057A, TPS2058A
 CURRENT-LIMITED POWER-DISTRIBUTION SWITCHES**

SLVS251A – SEPTEMBER 2000 – REVISED FEBRUARY 2001

PARAMETER MEASUREMENT INFORMATION

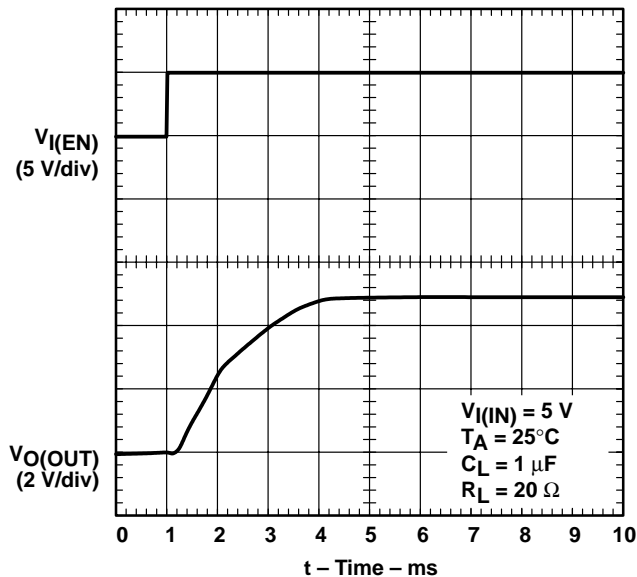

Figure 4. Turnon Delay and Rise Time With 1-µF Load

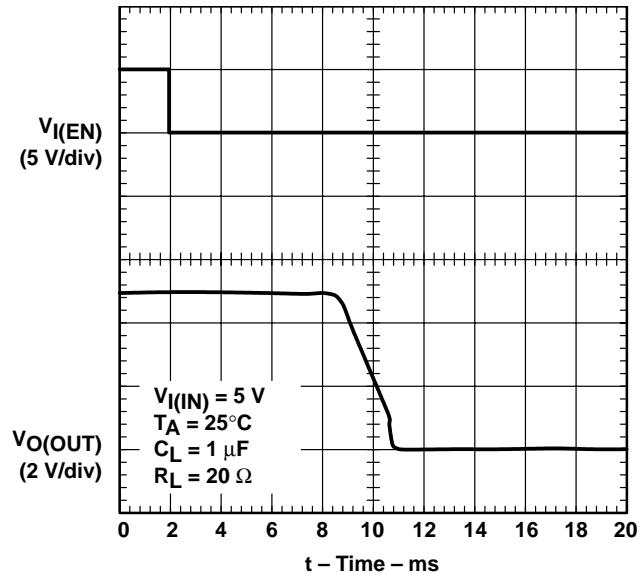

Figure 5. Turnoff Delay and Fall Time With 1-µF Load

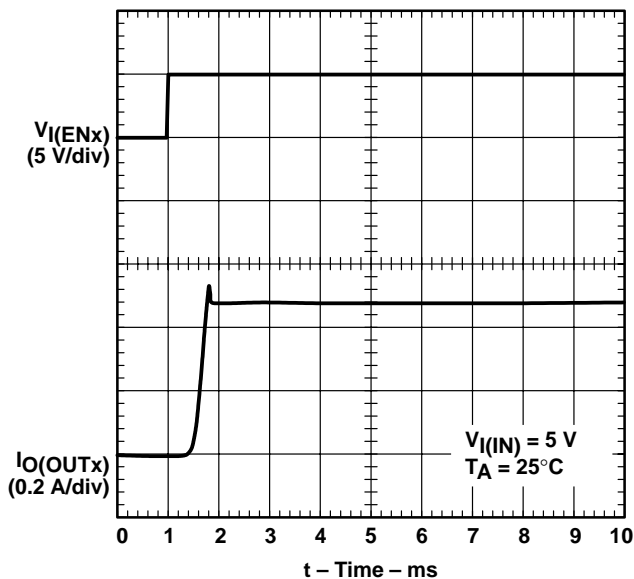

Figure 6. TPS2055A, Short-Circuit Current, Device Enabled Into Short

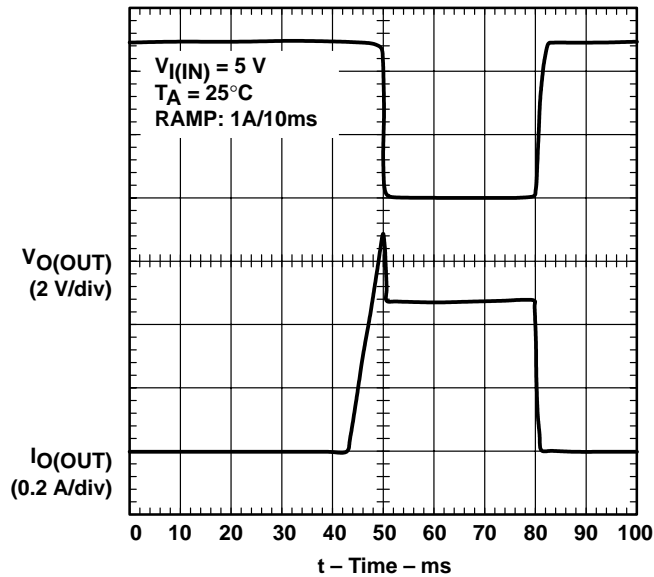

Figure 7. TPS2055A, Threshold Trip Current With Ramped Load on Enabled Device

PARAMETER MEASUREMENT INFORMATION

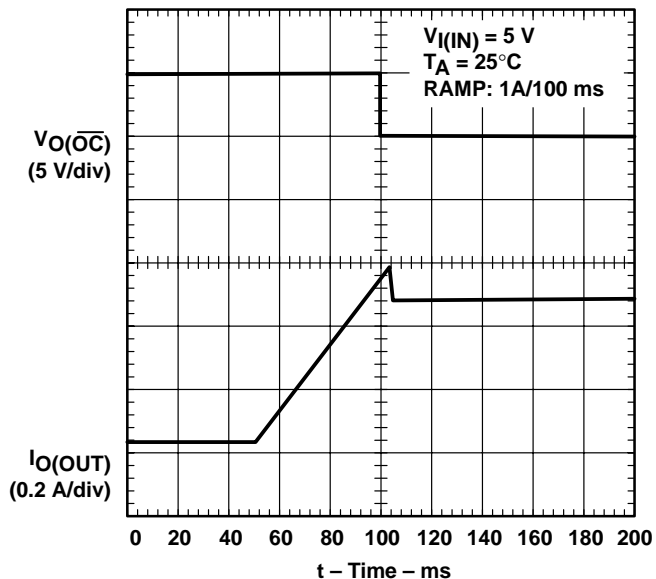

Figure 8. OC Response With Ramped Load on Enabled Device

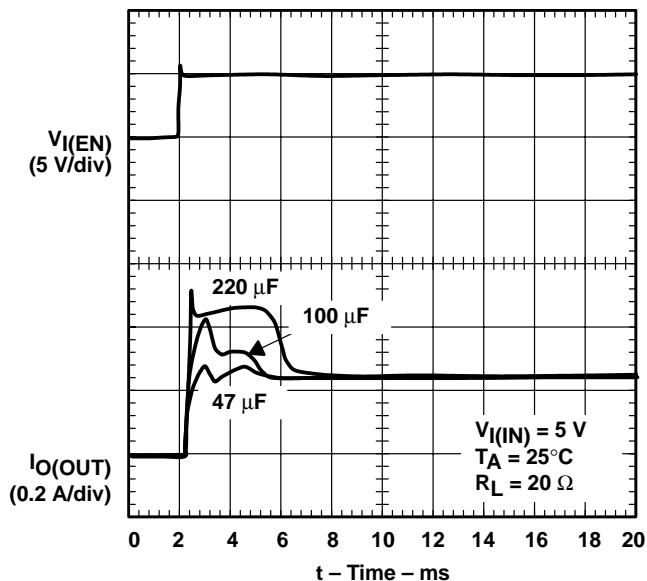

Figure 9. Inrush Current With 47-µF, 100-µF and 220-µF Load Capacitance

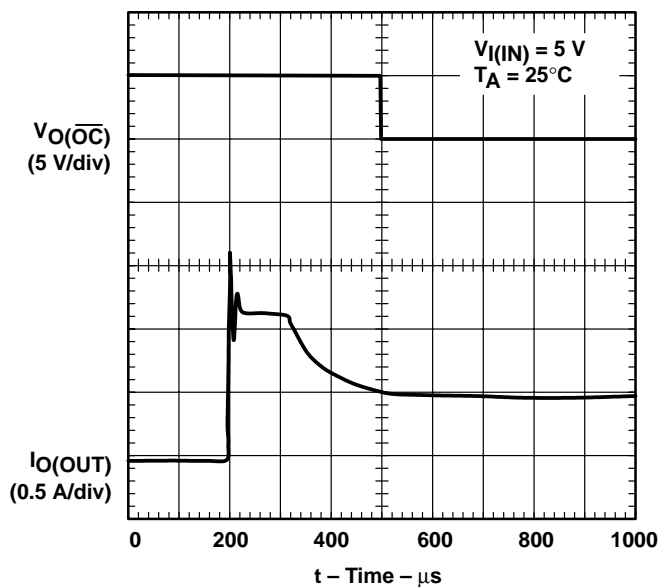

Figure 10. 4-Ω Load Connected to Enabled Device

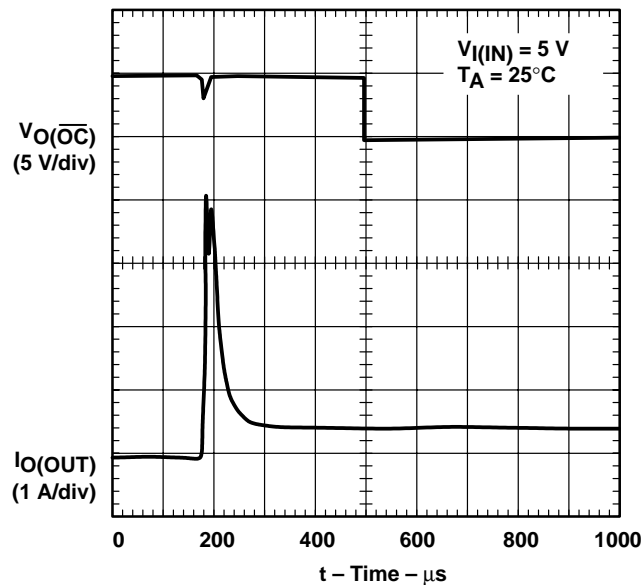

Figure 11. 1-Ω Load Connected to Enabled Device

**TPS2045A, TPS2046A, TPS2047A, TPS2048A
 TPS2055A, TPS2056A, TPS2057A, TPS2058A
 CURRENT-LIMITED POWER-DISTRIBUTION SWITCHES**

SLVS251A – SEPTEMBER 2000 – REVISED FEBRUARY 2001

TYPICAL CHARACTERISTICS

**TURNON DELAY TIME
 vs
 INPUT VOLTAGE**

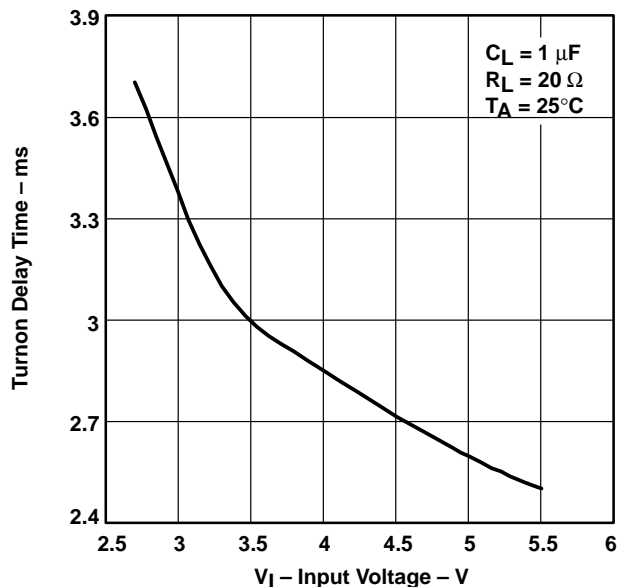

Figure 12

**TURNOFF DELAY TIME
 vs
 INPUT VOLTAGE**

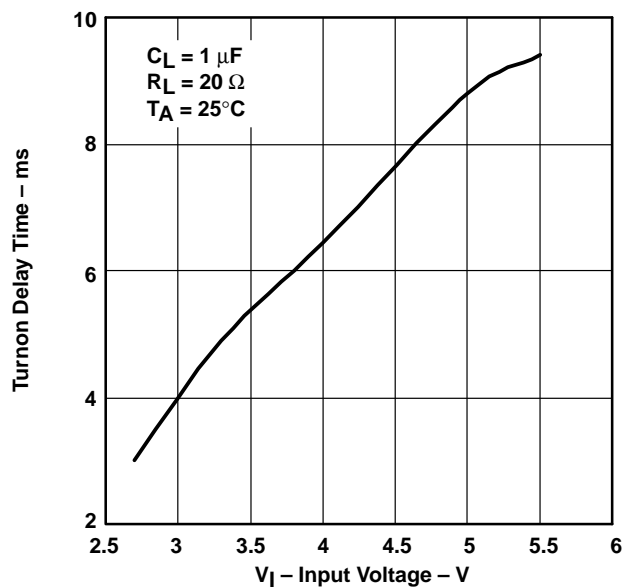

Figure 13

**RISE TIME
 vs
 INPUT VOLTAGE**

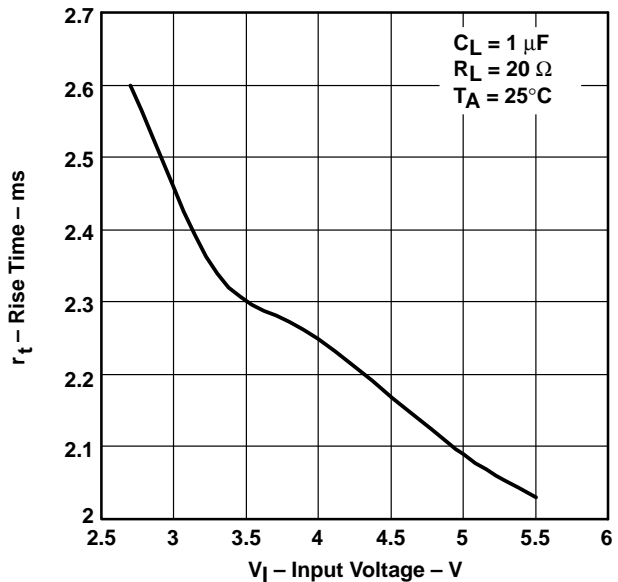

Figure 14

**FALL TIME
 vs
 INPUT VOLTAGE**

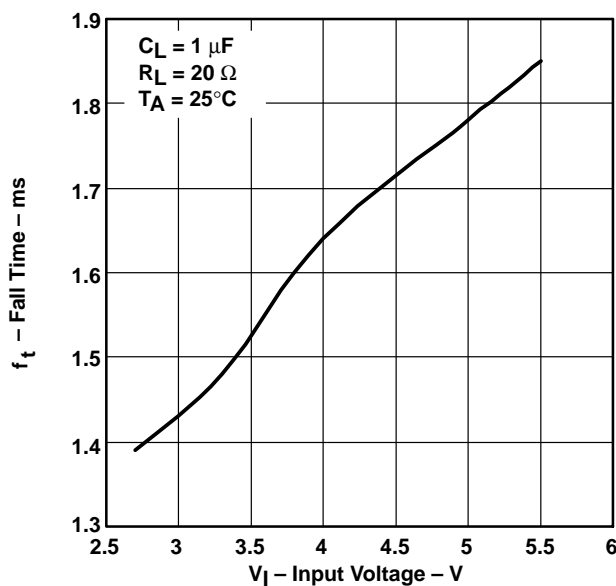

Figure 15

TPS2045A, TPS2046A, TPS2047A, TPS2048A
 TPS2055A, TPS2056A, TPS2057A, TPS2058A
CURRENT-LIMITED POWER-DISTRIBUTION SWITCHES
 SLVS251A – SEPTEMBER 2000 – REVISED FEBRUARY 2001

TYPICAL CHARACTERISTICS

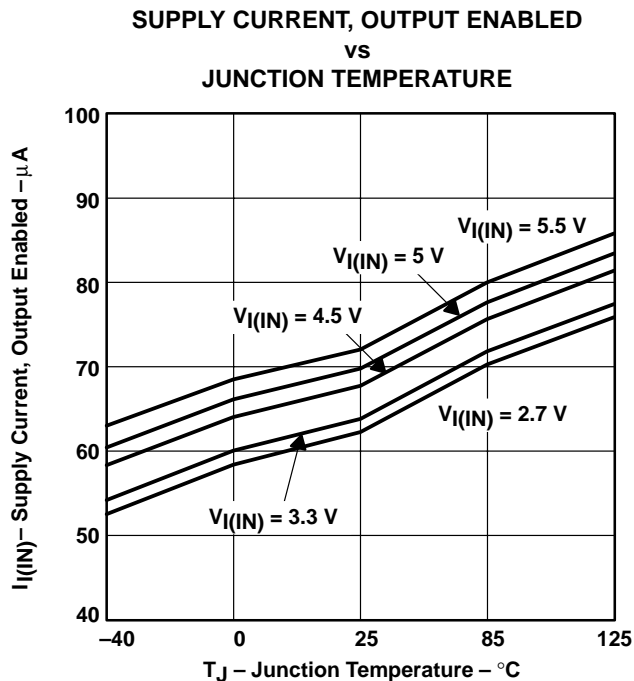

Figure 16

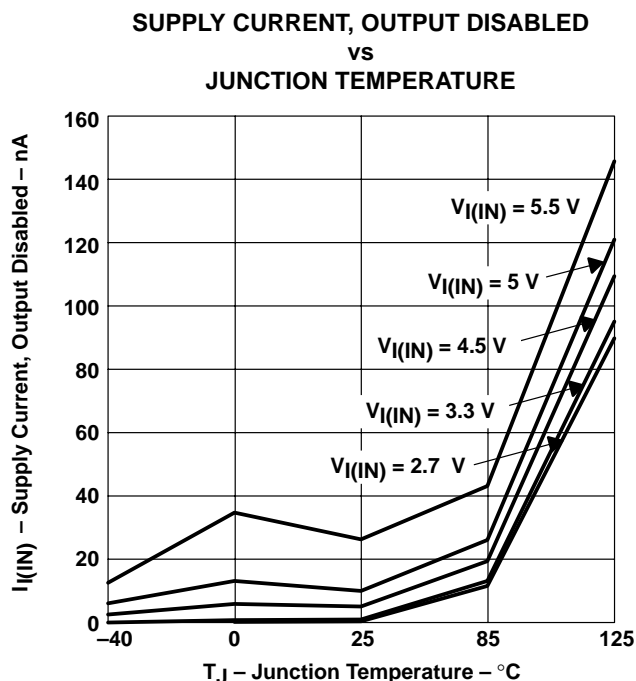

Figure 17

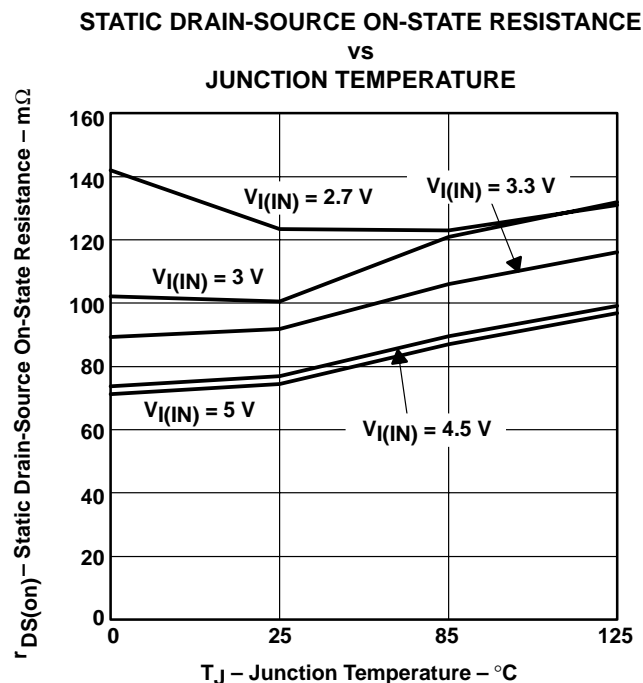

Figure 18

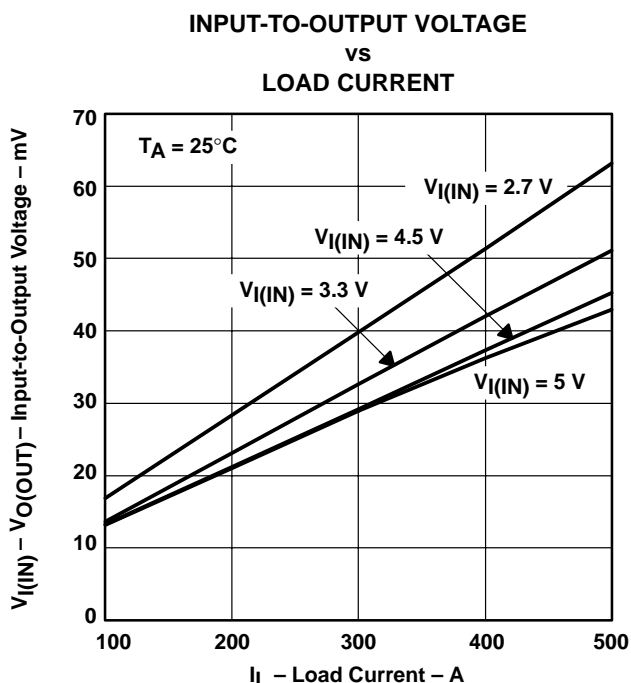

Figure 19

**TPS2045A, TPS2046A, TPS2047A, TPS2048A
 TPS2055A, TPS2056A, TPS2057A, TPS2058A
 CURRENT-LIMITED POWER-DISTRIBUTION SWITCHES**

SLVS251A – SEPTEMBER 2000 – REVISED FEBRUARY 2001

TYPICAL CHARACTERISTICS

**SHORT-CIRCUIT OUTPUT CURRENT
 vs
 JUNCTION TEMPERATURE**

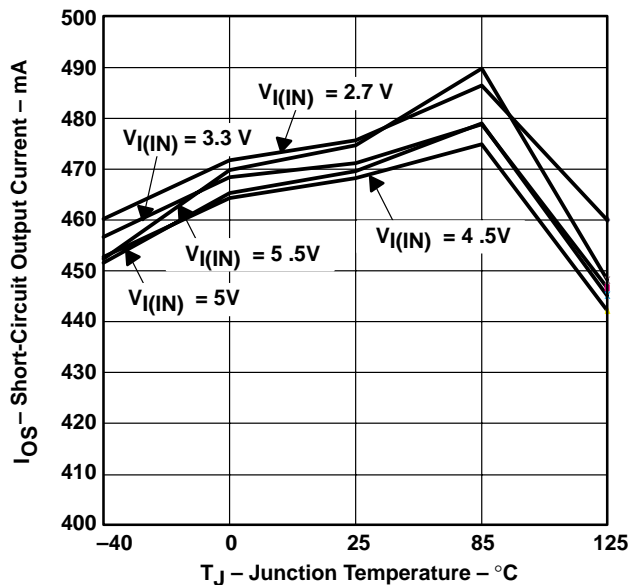

Figure 20

**THRESHOLD TRIP CURRENT
 vs
 INPUT VOLTAGE**

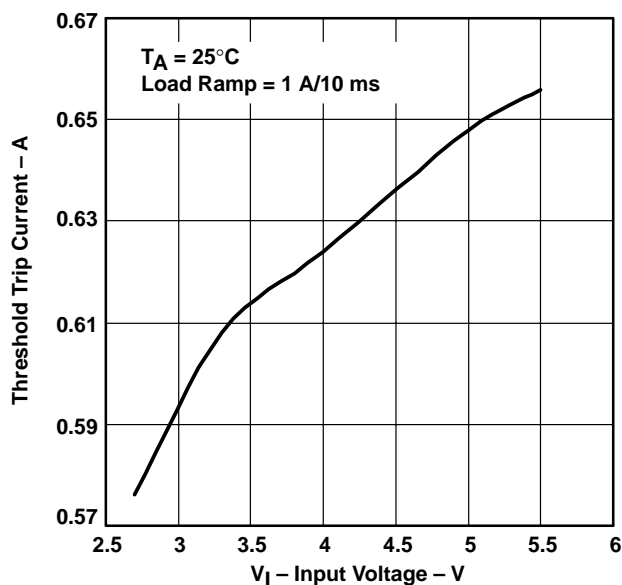

Figure 21

**UNDERVOLTAGE LOCKOUT
 vs
 JUNCTION TEMPERATURE**

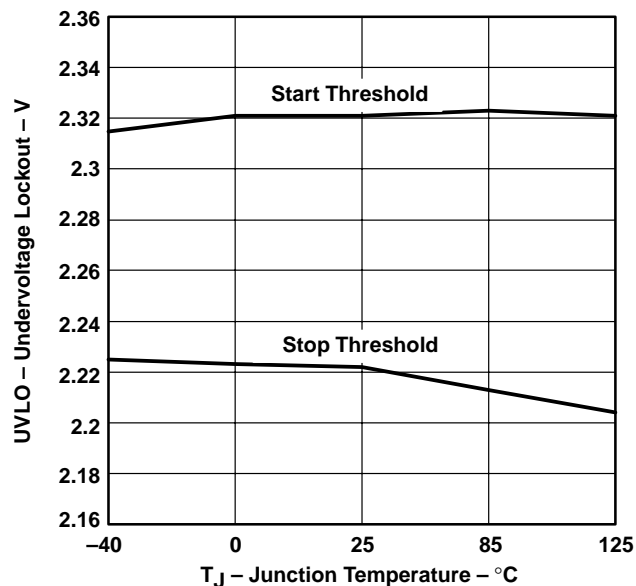

Figure 22

**CURRENT-LIMIT RESPONSE
 vs
 PEAK CURRENT**

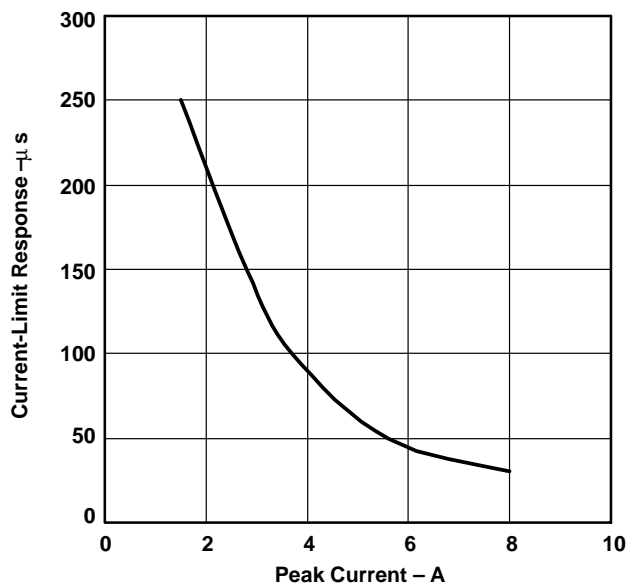

Figure 23

TPS2045A, TPS2046A, TPS2047A, TPS2048A
TPS2055A, TPS2056A, TPS2057A, TPS2058A
CURRENT-LIMITED POWER-DISTRIBUTION SWITCHES
SLVS251A – SEPTEMBER 2000 – REVISED FEBRUARY 2001

APPLICATION INFORMATION

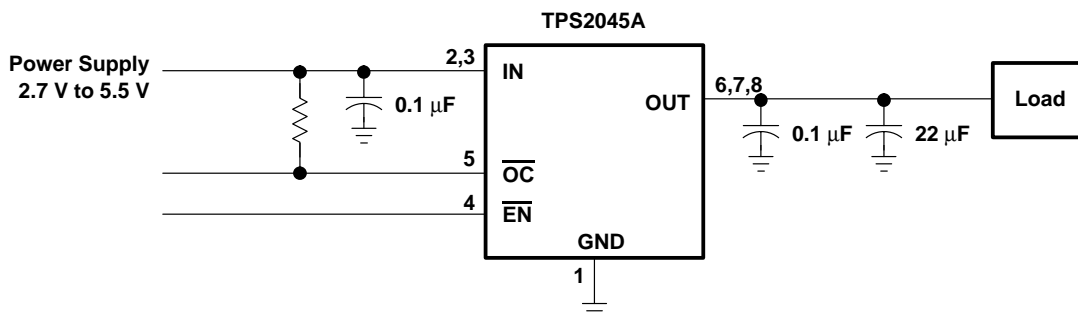

Figure 24. Typical Application (Example, TPS2045A)

power-supply considerations

A 0.01- μF to 0.1- μF ceramic bypass capacitor between IN_x and GND, close to the device, is recommended. Placing a high-value electrolytic capacitor on the output pin(s) is recommended when the output load is heavy. This precaution reduces power-supply transients that may cause ringing on the input. Additionally, bypassing the output with a 0.01- μF to 0.1- μF ceramic capacitor improves the immunity of the device to short-circuit transients.

overcurrent

A sense FET is employed to check for overcurrent conditions. Unlike current-sense resistors, sense FETs do not increase the series resistance of the current path. When an overcurrent condition is detected, the device maintains a constant output current and reduces the output voltage accordingly. Complete shutdown occurs only if the fault is present long enough to activate thermal limiting.

Three possible overload conditions can occur. In the first condition, the output has been shorted before the device is enabled or before $V_{\text{I(IN)}}$ has been applied (see Figure 6). The TPS204xA and TPS205xA sense the short and immediately switch into a constant-current output.

In the second condition, a short or an overload occurs while the device is enabled. At the instant the overload occurs, very high currents may flow for a short time before the current-limit circuit can react. After the current-limit circuit has tripped (reached the overcurrent trip threshold) the device switches into constant-current mode.

In the third condition, the load has been gradually increased beyond the recommended operating current. The current is permitted to rise until the current-limit threshold is reached or until the thermal limit of the device is exceeded (see Figure 7). The TPS204xA and TPS205xA are capable of delivering current up to the current-limit threshold without damaging the device. Once the threshold has been reached, the device switches into its constant-current mode.

$\overline{\text{OC}}$ response

The $\overline{\text{OC}}$ open-drain output is asserted (active low) when an overcurrent or overtemperature condition is encountered. The output will remain asserted until the overcurrent or overtemperature condition is removed. Connecting a heavy capacitive load to an enabled device can cause momentary false overcurrent reporting from the inrush current flowing through the device, charging the downstream capacitor. The TPS204xA and TPS205xA family of devices are designed to reduce false overcurrent reporting. An internal overcurrent transient filter eliminates the need for external components to remove unwanted pulses. Using low-ESR electrolytic capacitors on the output lowers the inrush current flow through the device during hot-plug events by providing a low-impedance energy source, also reducing erroneous overcurrent reporting.

**TPS2045A, TPS2046A, TPS2047A, TPS2048A
 TPS2055A, TPS2056A, TPS2057A, TPS2058A
 CURRENT-LIMITED POWER-DISTRIBUTION SWITCHES**
 SLVS251A – SEPTEMBER 2000 – REVISED FEBRUARY 2001

APPLICATION INFORMATION

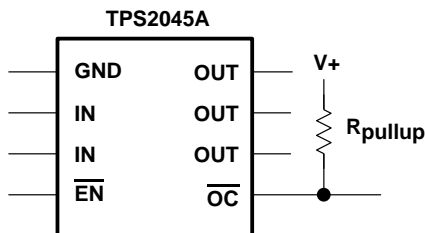

Figure 25. Typical Circuit for \overline{OC} Pin (Example, TPS2045A)

power dissipation and junction temperature

The low on-resistance on the n-channel MOSFET allows small surface-mount packages, such as SOIC, to pass large currents. The thermal resistances of these packages are high compared to those of power packages; it is good design practice to check power dissipation and junction temperature. Begin by determining the $r_{DS(on)}$ of the N-channel MOSFET relative to the input voltage and operating temperature. As an initial estimate, use the highest operating ambient temperature of interest and read $r_{DS(on)}$ from Figure 18. Using this value, the power dissipation per switch can be calculated by:

$$P_D = r_{DS(on)} \times I^2$$

Depending on which device is being used, multiply this number by the number of switches being used. This step will render the total power dissipation from the N-channel MOSFETs.

Finally, calculate the junction temperature:

$$T_J = P_D \times R_{\theta JA} + T_A$$

Where:

- T_A = Ambient temperature °C
- $R_{\theta JA}$ = Thermal resistance SOIC = 172°C/W (for 8 pin), 111°C/W (for 16 pin)
- P_D = Total power dissipation based on number of switches being used.

Compare the calculated junction temperature with the initial estimate. If they do not agree within a few degrees, repeat the calculation, using the calculated value as the new estimate. Two or three iterations are generally sufficient to get a reasonable answer.

thermal protection

Thermal protection prevents damage to the IC when heavy-overload or short-circuit faults are present for extended periods of time. The faults force the TPS204xA and TPS205xA into constant-current mode, which causes the voltage across the high-side switch to increase; under short-circuit conditions, the voltage across the switch is equal to the input voltage. The increased dissipation causes the junction temperature to rise to high levels. The protection circuit senses the junction temperature of the switch and shuts it off. Hysteresis is built into the thermal sense circuit, and after the device has cooled approximately 20 degrees, the switch turns back on. The switch continues to cycle in this manner until the load fault or input power is removed.

The TPS204xA and TPS205xA implement a dual thermal trip to allow fully independent operation of the power distribution switches. In an overcurrent or short-circuit condition the junction temperature will rise. Once the die temperature rises to approximately 140°C, the internal thermal sense circuitry checks which power switch is in an overcurrent condition and turns that power switch off, thus isolating the fault without interrupting operation of the adjacent power switch. Should the die temperature exceed the first thermal trip point of 140°C and reach 160°C, both switches turn off. The \overline{OC} open-drain output is asserted (active low) when overtemperature or overcurrent occurs.

APPLICATION INFORMATION

undervoltage lockout (UVLO)

An undervoltage lockout ensures that the power switch is in the off state at power up. Whenever the input voltage falls below approximately 2 V, the power switch will be quickly turned off. This facilitates the design of hot-insertion systems where it is not possible to turn off the power switch before input power is removed. The UVLO will also keep the switch from being turned on until the power supply has reached at least 2 V, even if the switch is enabled. Upon reinsertion, the power switch will be turned on, with a controlled rise time to reduce EMI and voltage overshoots.

universal serial bus (USB) applications

The universal serial bus (USB) interface is a 12-Mb/s, or 1.5-Mb/s, multiplexed serial bus designed for low-to-medium bandwidth PC peripherals (e.g., keyboards, printers, scanners, and mice). The four-wire USB interface is conceived for dynamic attach-detach (hot plug-unplug) of peripherals. Two lines are provided for differential data, and two lines are provided for 5-V power distribution.

USB data is a 3.3-V level signal, but power is distributed at 5 V to allow for voltage drops in cases where power is distributed through more than one hub across long cables. Each function must provide its own regulated 3.3 V from the 5-V input or its own internal power supply.

The USB specification defines the following five classes of devices, each differentiated by power-consumption requirements:

- Hosts/self-powered hubs (SPH)
- Bus-powered hubs (BPH)
- Low-power, bus-powered functions
- High-power, bus-powered functions
- Self-powered functions

Self-powered and bus-powered hubs distribute data and power to downstream functions. The TPS204xA and TPS205xA can provide power-distribution solutions for many of these classes of devices.

host/self-powered and bus-powered hubs

Hosts and self-powered hubs have a local power supply that powers the embedded functions and the downstream ports. This power supply must provide from 5.25 V to 4.75 V to the board side of the downstream connection under full-load and no-load conditions. Hosts and SPHs are required to have current-limit protection and must report overcurrent conditions to the USB controller. Typical SPHs are desktop PCs, monitors, printers, and stand-alone hubs.

Bus-powered hubs obtain all power from upstream ports and often contain an embedded function. The hubs are required to power up with less than one unit load. The BPH usually has one embedded function, and power is always available to the controller of the hub. If the embedded function and hub require more than 100 mA on power up, the power to the embedded function may need to be kept off until enumeration is completed. This can be accomplished by removing power or by shutting off the clock to the embedded function. Power switching the embedded function is not necessary if the aggregate power draw for the function and controller is less than one unit load. The total current drawn by the bus-powered device is the sum of the current to the controller, the embedded function, and the downstream ports, and it is limited to 500 mA from an upstream port.

TPS2045A, TPS2046A, TPS2047A, TPS2048A TPS2055A, TPS2056A, TPS2057A, TPS2058A CURRENT-LIMITED POWER-DISTRIBUTION SWITCHES

SLVS251A – SEPTEMBER 2000 – REVISED FEBRUARY 2001

APPLICATION INFORMATION

low-power bus-powered functions and high-power bus-powered functions

Both low-power and high-power bus-powered functions obtain all power from upstream ports; low-power functions always draw less than 100 mA (see Figure 26); high-power functions must draw less than 100 mA at power up and can draw up to 500 mA after enumeration. If the load of the function is more than the parallel combination of 44 Ω and 10 μF at power up, the device must implement inrush current limiting.

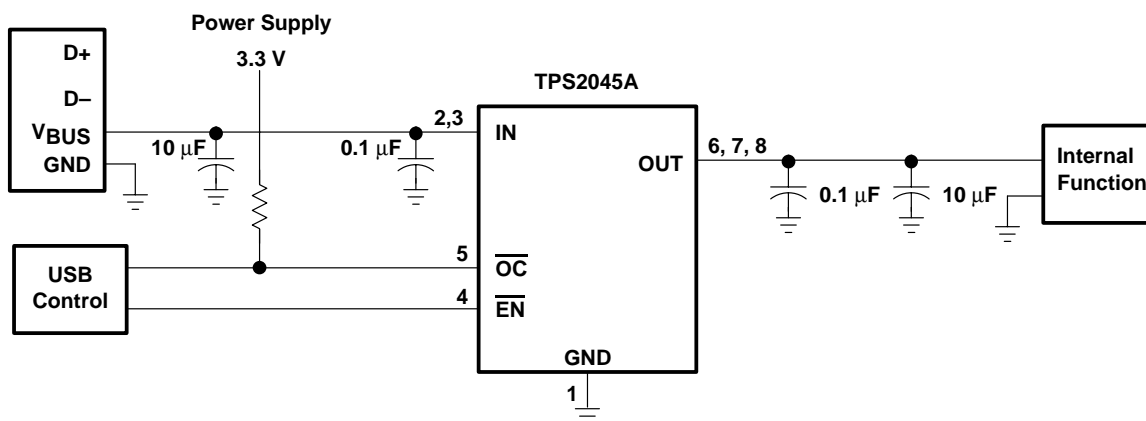

Figure 26. Low-Power Bus-Powered Function (Example, TPS2045A)

USB power-distribution requirements

USB can be implemented in several ways, and, regardless of the type of USB device being developed, several power-distribution features must be implemented.

- Hosts/self-powered hubs must:
 - Current-limit downstream ports
 - Report overcurrent conditions on USB V_{BUS}
- Bus-powered hubs must:
 - Enable/disable power to downstream ports
 - Power up at <100 mA
 - Limit inrush current (<44 Ω and 10 μF)
- Functions must:
 - Limit inrush currents
 - Power up at <100 mA

The feature set of the TPS204xA and TPS205xA allows them to meet each of these requirements. The integrated current-limiting and overcurrent reporting is required by hosts and self-powered hubs. The logic-level enable and controlled rise times meet the need of both input and output ports on bus-power hubs, as well as the input ports for bus-power functions.

**TPS2045A, TPS2046A, TPS2047A, TPS2048A
TPS2055A, TPS2056A, TPS2057A, TPS2058A
CURRENT-LIMITED POWER-DISTRIBUTION SWITCHES**
SLVS251A – SEPTEMBER 2000 – REVISED FEBRUARY 2001

APPLICATION INFORMATION

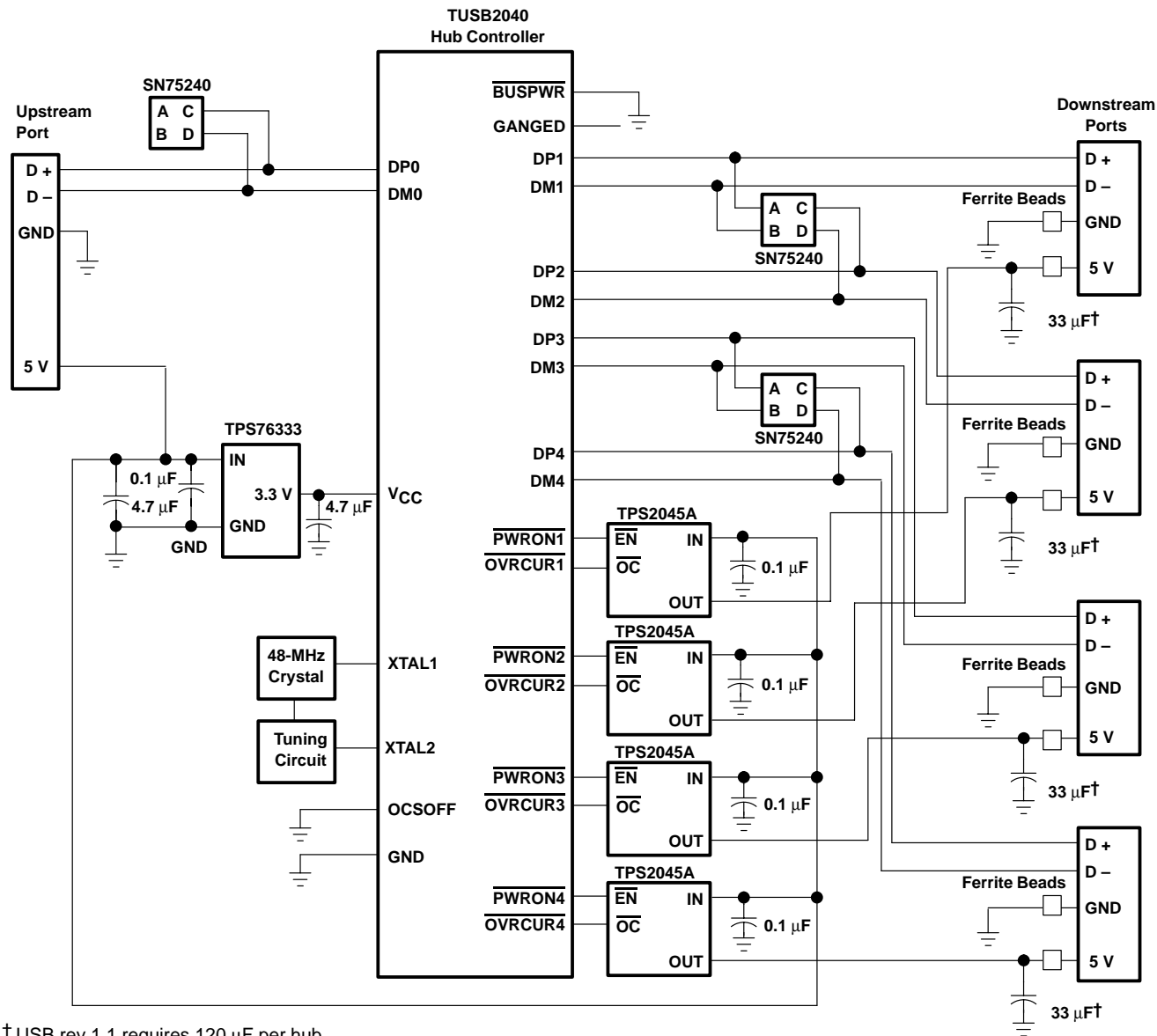
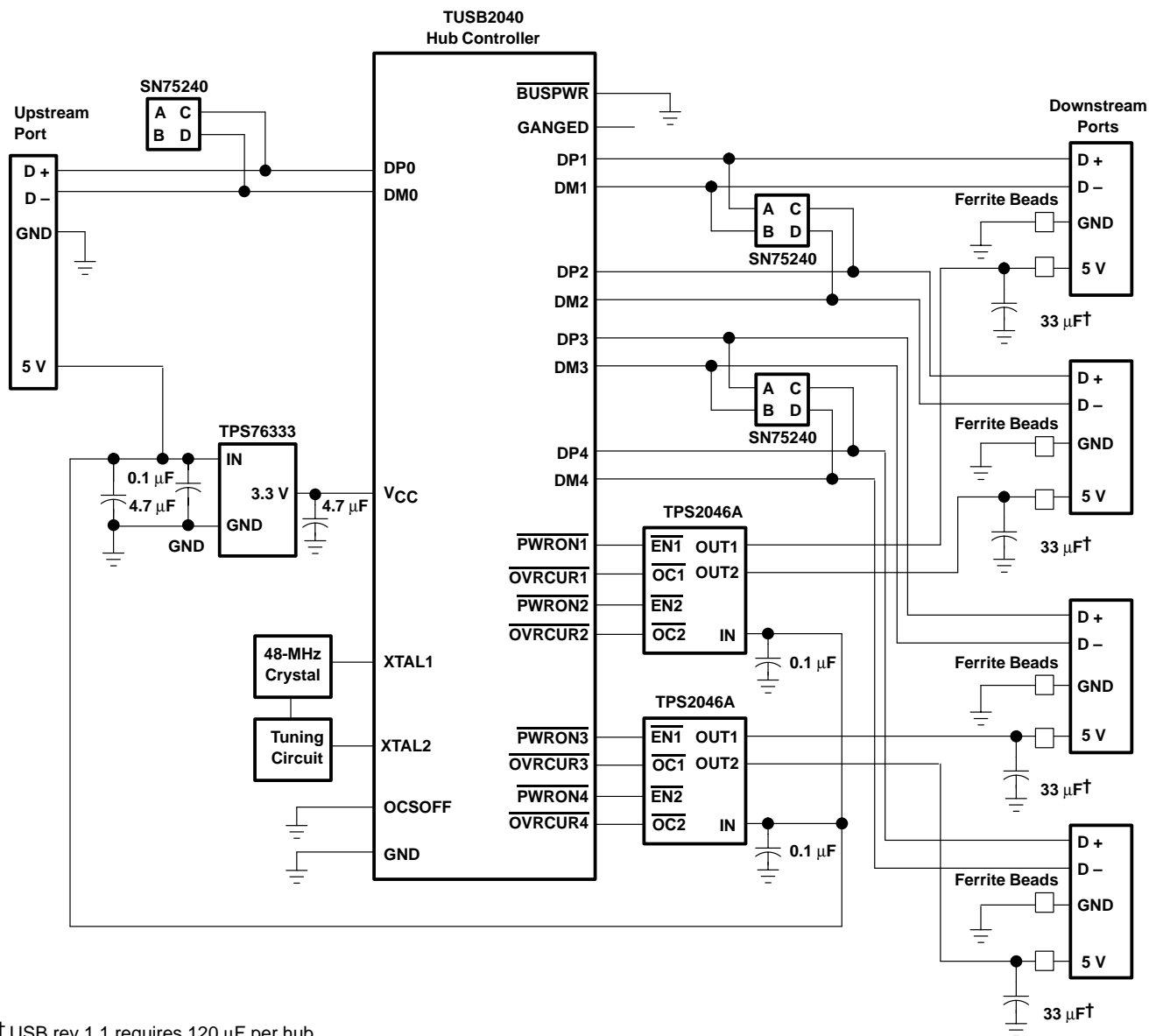

Figure 27. Bus-Powered Hub Implementation, TPS2045A

TPS2045A, TPS2046A, TPS2047A, TPS2048A
TPS2055A, TPS2056A, TPS2057A, TPS2058A
CURRENT-LIMITED POWER-DISTRIBUTION SWITCHES
 SLVS251A – SEPTEMBER 2000 – REVISED FEBRUARY 2001

APPLICATION INFORMATION



† USB rev 1.1 requires 120 µF per hub.

Figure 28. Bus-Powered Hub Implementation, TPS2046A

**TPS2045A, TPS2046A, TPS2047A, TPS2048A
 TPS2055A, TPS2056A, TPS2057A, TPS2058A
 CURRENT-LIMITED POWER-DISTRIBUTION SWITCHES**
 SLVS251A – SEPTEMBER 2000 – REVISED FEBRUARY 2001

APPLICATION INFORMATION

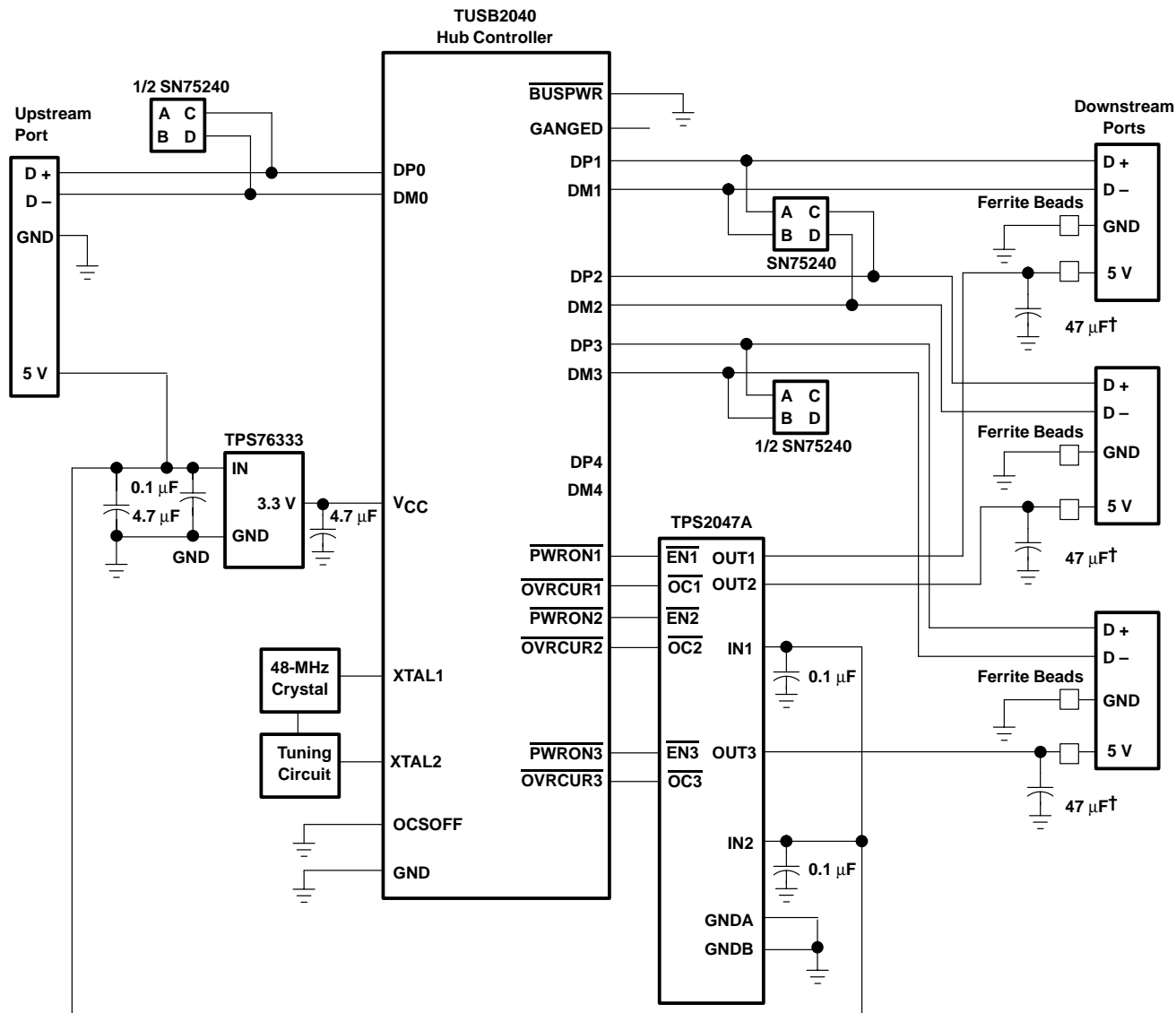

† USB rev 1.1 requires 120 µF per hub.

Figure 29. Bus-Powered Hub Implementation, TPS2047A

TPS2045A, TPS2046A, TPS2047A, TPS2048A
TPS2055A, TPS2056A, TPS2057A, TPS2058A
CURRENT-LIMITED POWER-DISTRIBUTION SWITCHES
 SLVS251A – SEPTEMBER 2000 – REVISED FEBRUARY 2001

APPLICATION INFORMATION

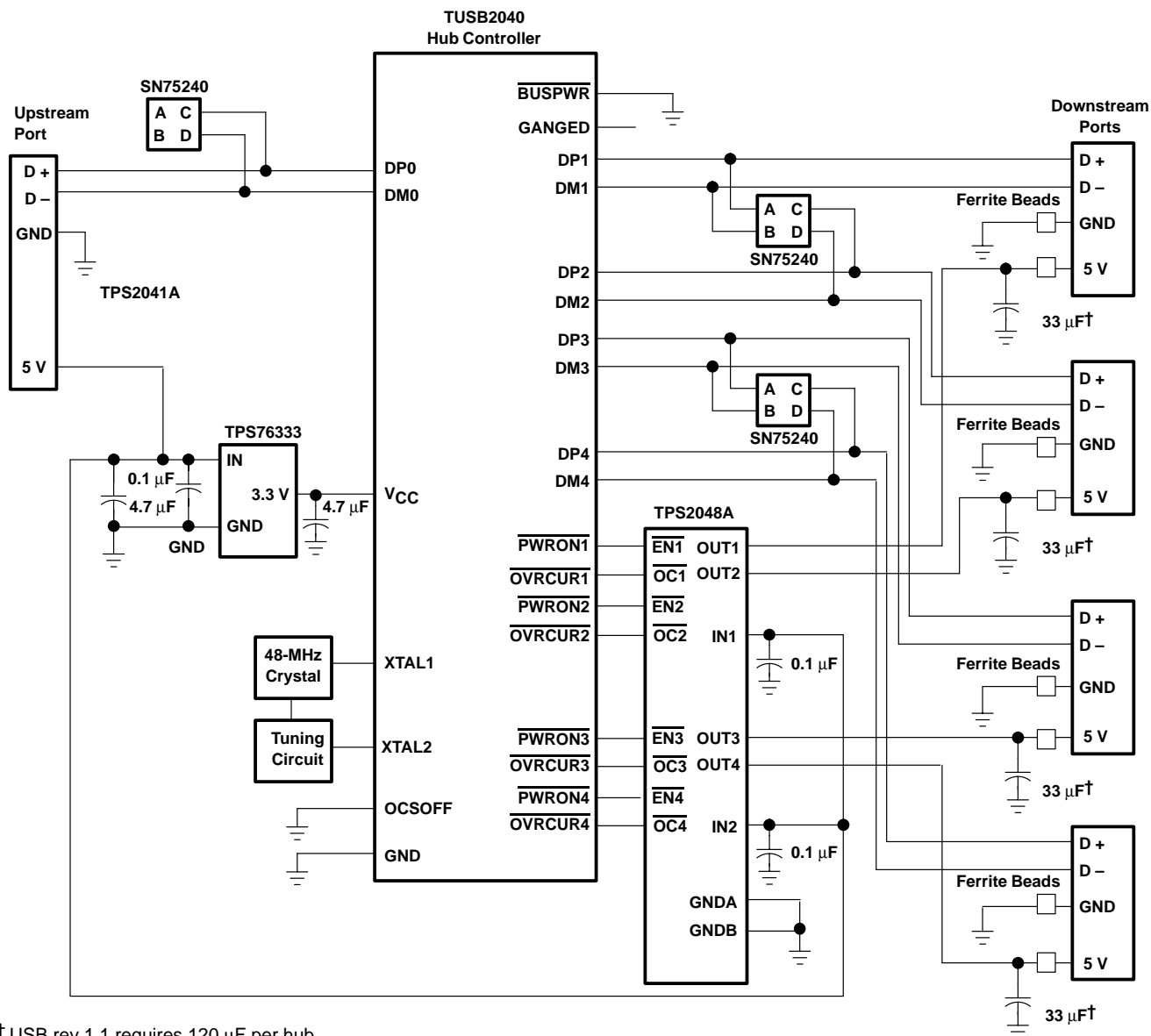

† USB rev 1.1 requires 120 µF per hub.

Figure 30. Bus-Powered Hub Implementation, TPS2048A

APPLICATION INFORMATION

generic hot-plug applications (see Figure 31)

In many applications it may be necessary to remove modules or pc boards while the main unit is still operating. These are considered hot-plug applications. Such implementations require the control of current surges seen by the main power supply and the card being inserted. The most effective way to control these surges is to limit and slowly ramp the current and voltage being applied to the card, similar to the way in which a power supply normally turns on. Due to the controlled rise times and fall times of the TPS204xA and TPS205xA, these devices can be used to provide a softer start-up to devices being hot-plugged into a powered system. The UVLO feature of the TPS204xA and TPS205xA also ensures the switch will be off after the card has been removed, and the switch will be off during the next insertion. The UVLO feature insures a soft start with a controlled rise time for every insertion of the card or module.

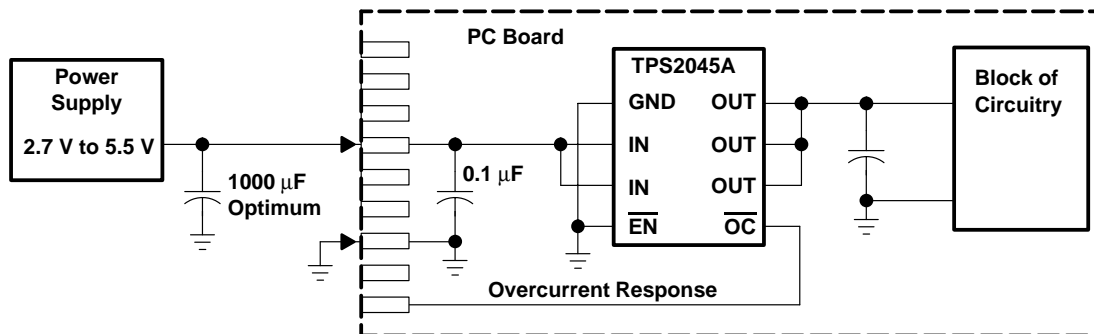

Figure 31. Typical Hot-Plug Implementation (Example, TPS2045A)

By placing the TPS204xA and TPS205xA between the V_{CC} input and the rest of the circuitry, the input power will reach these devices first after insertion. The typical rise time of the switch is approximately 2.5 ms, providing a slow voltage ramp at the output of the device. This implementation controls system surge currents and provides a hot-plugging mechanism for any device.

TPS2045A, TPS2046A, TPS2047A, TPS2048A
TPS2055A, TPS2056A, TPS2057A, TPS2058A
CURRENT-LIMITED POWER-DISTRIBUTION SWITCHES

SLVS251A – SEPTEMBER 2000 – REVISED FEBRUARY 2001

MECHANICAL DATA

D (R-PDSO-G)**

PLASTIC SMALL-OUTLINE PACKAGE

14 PIN SHOWN

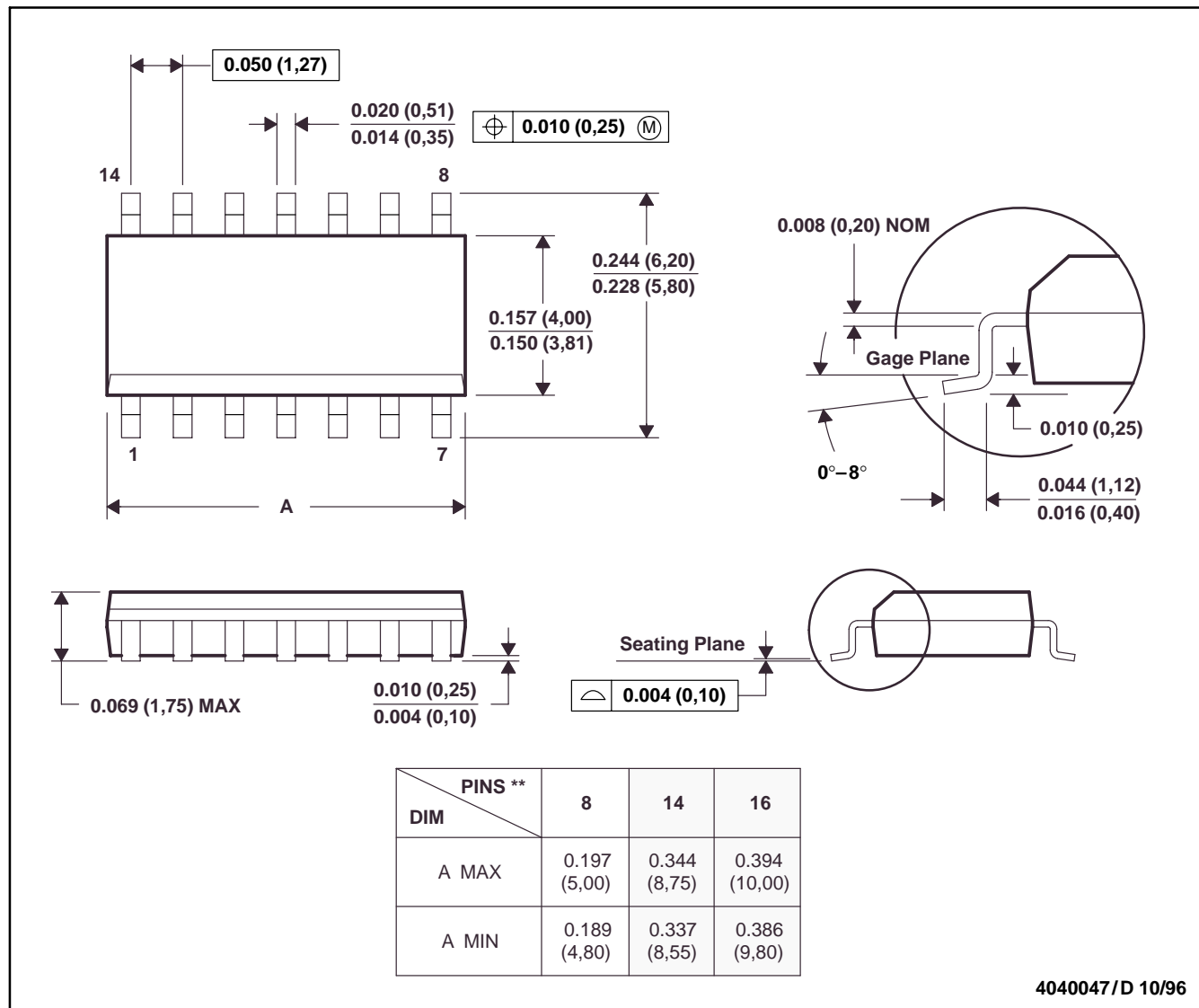

4040047/D 10/96

- NOTES: A. All linear dimensions are in inches (millimeters).
 B. This drawing is subject to change without notice.
 C. Body dimensions do not include mold flash or protrusion, not to exceed 0.006 (0,15).
 D. Falls within JEDEC MS-012

PACKAGING INFORMATION

Orderable Device	Status ⁽¹⁾	Package Type	Package Drawing	Pins	Package Qty	Eco Plan ⁽²⁾	Lead/Ball Finish	MSL Peak Temp ⁽³⁾
TPS2045AD	ACTIVE	SOIC	D	8	75	Green (RoHS & no Sb/Br)	CU NIPDAU	Level-1-260C-UNLIM
TPS2045ADR	ACTIVE	SOIC	D	8	2500	Green (RoHS & no Sb/Br)	CU NIPDAU	Level-1-260C-UNLIM
TPS2045ADRG4	ACTIVE	SOIC	D	8	2500	Green (RoHS & no Sb/Br)	CU NIPDAU	Level-2-260C-1 YEAR
TPS2046AD	ACTIVE	SOIC	D	8	75	Green (RoHS & no Sb/Br)	CU NIPDAU	Level-1-260C-UNLIM
TPS2046ADR	ACTIVE	SOIC	D	8	2500	Green (RoHS & no Sb/Br)	CU NIPDAU	Level-1-260C-UNLIM
TPS2046ADRG4	ACTIVE	SOIC	D	8		Green (RoHS & no Sb/Br)	CU NIPDAU	Level-2-260C-1 YEAR
TPS2047AD	ACTIVE	SOIC	D	16	40	Green (RoHS & no Sb/Br)	CU NIPDAU	Level-1-260C-UNLIM
TPS2047ADR	ACTIVE	SOIC	D	16	2500	Green (RoHS & no Sb/Br)	CU NIPDAU	Level-1-260C-UNLIM
TPS2047ADRG4	ACTIVE	SOIC	D	16	2500	Green (RoHS & no Sb/Br)	CU NIPDAU	Level-1-260C-UNLIM
TPS2048AD	ACTIVE	SOIC	D	16	40	Green (RoHS & no Sb/Br)	CU NIPDAU	Level-1-260C-UNLIM
TPS2048ADG4	ACTIVE	SOIC	D	16	40	Green (RoHS & no Sb/Br)	CU NIPDAU	Level-1-260C-UNLIM
TPS2048ADR	ACTIVE	SOIC	D	16	2500	Green (RoHS & no Sb/Br)	CU NIPDAU	Level-1-260C-UNLIM
TPS2048ADRG4	ACTIVE	SOIC	D	16	2500	Green (RoHS & no Sb/Br)	CU NIPDAU	Level-1-260C-UNLIM
TPS2055AD	ACTIVE	SOIC	D	8	75	Green (RoHS & no Sb/Br)	CU NIPDAU	Level-1-260C-UNLIM
TPS2055ADR	ACTIVE	SOIC	D	8	2500	Green (RoHS & no Sb/Br)	CU NIPDAU	Level-1-260C-UNLIM
TPS2055ADRG4	ACTIVE	SOIC	D	8	2500	Green (RoHS & no Sb/Br)	CU NIPDAU	Level-1-260C-UNLIM
TPS2056AD	ACTIVE	SOIC	D	8	75	Green (RoHS & no Sb/Br)	CU NIPDAU	Level-1-260C-UNLIM
TPS2056ADR	ACTIVE	SOIC	D	8	2500	Green (RoHS & no Sb/Br)	CU NIPDAU	Level-1-260C-UNLIM
TPS2056ADRG4	ACTIVE	SOIC	D	8	2500	Green (RoHS & no Sb/Br)	CU NIPDAU	Level-1-260C-UNLIM
TPS2057AD	ACTIVE	SOIC	D	16	40	Green (RoHS & no Sb/Br)	CU NIPDAU	Level-1-260C-UNLIM
TPS2057ADG4	ACTIVE	SOIC	D	16	40	Green (RoHS & no Sb/Br)	CU NIPDAU	Level-1-260C-UNLIM
TPS2057ADR	ACTIVE	SOIC	D	16	2500	Green (RoHS & no Sb/Br)	CU NIPDAU	Level-1-260C-UNLIM
TPS2057ADRG4	ACTIVE	SOIC	D	16	2500	Green (RoHS & no Sb/Br)	CU NIPDAU	Level-1-260C-UNLIM
TPS2058AD	ACTIVE	SOIC	D	16	40	Green (RoHS & no Sb/Br)	CU NIPDAU	Level-1-260C-UNLIM
TPS2058ADR	ACTIVE	SOIC	D	16	2500	Green (RoHS & no Sb/Br)	CU NIPDAU	Level-1-260C-UNLIM

Orderable Device	Status ⁽¹⁾	Package Type	Package Drawing	Pins	Package Qty	Eco Plan ⁽²⁾	Lead/Ball Finish	MSL Peak Temp ⁽³⁾
TPS2058ADRG4	ACTIVE	SOIC	D	16	2500	Green (RoHS & no Sb/Br)	CU NIPDAU	Level-1-260C-UNLIM

⁽¹⁾ The marketing status values are defined as follows:

ACTIVE: Product device recommended for new designs.

LIFEBUY: TI has announced that the device will be discontinued, and a lifetime-buy period is in effect.

NRND: Not recommended for new designs. Device is in production to support existing customers, but TI does not recommend using this part in a new design.

PREVIEW: Device has been announced but is not in production. Samples may or may not be available.

OBSELETE: TI has discontinued the production of the device.

⁽²⁾ Eco Plan - The planned eco-friendly classification: Pb-Free (RoHS) or Green (RoHS & no Sb/Br) - please check <http://www.ti.com/productcontent> for the latest availability information and additional product content details.

TBD: The Pb-Free/Green conversion plan has not been defined.

Pb-Free (RoHS): TI's terms "Lead-Free" or "Pb-Free" mean semiconductor products that are compatible with the current RoHS requirements for all 6 substances, including the requirement that lead not exceed 0.1% by weight in homogeneous materials. Where designed to be soldered at high temperatures, TI Pb-Free products are suitable for use in specified lead-free processes.

Green (RoHS & no Sb/Br): TI defines "Green" to mean Pb-Free (RoHS compatible), and free of Bromine (Br) and Antimony (Sb) based flame retardants (Br or Sb do not exceed 0.1% by weight in homogeneous material)

⁽³⁾ MSL, Peak Temp. -- The Moisture Sensitivity Level rating according to the JEDEC industry standard classifications, and peak solder temperature.

Important Information and Disclaimer:The information provided on this page represents TI's knowledge and belief as of the date that it is provided. TI bases its knowledge and belief on information provided by third parties, and makes no representation or warranty as to the accuracy of such information. Efforts are underway to better integrate information from third parties. TI has taken and continues to take reasonable steps to provide representative and accurate information but may not have conducted destructive testing or chemical analysis on incoming materials and chemicals. TI and TI suppliers consider certain information to be proprietary, and thus CAS numbers and other limited information may not be available for release.

In no event shall TI's liability arising out of such information exceed the total purchase price of the TI part(s) at issue in this document sold by TI to Customer on an annual basis.

IMPORTANT NOTICE

Texas Instruments Incorporated and its subsidiaries (TI) reserve the right to make corrections, modifications, enhancements, improvements, and other changes to its products and services at any time and to discontinue any product or service without notice. Customers should obtain the latest relevant information before placing orders and should verify that such information is current and complete. All products are sold subject to TI's terms and conditions of sale supplied at the time of order acknowledgment.

TI warrants performance of its hardware products to the specifications applicable at the time of sale in accordance with TI's standard warranty. Testing and other quality control techniques are used to the extent TI deems necessary to support this warranty. Except where mandated by government requirements, testing of all parameters of each product is not necessarily performed.

TI assumes no liability for applications assistance or customer product design. Customers are responsible for their products and applications using TI components. To minimize the risks associated with customer products and applications, customers should provide adequate design and operating safeguards.

TI does not warrant or represent that any license, either express or implied, is granted under any TI patent right, copyright, mask work right, or other TI intellectual property right relating to any combination, machine, or process in which TI products or services are used. Information published by TI regarding third-party products or services does not constitute a license from TI to use such products or services or a warranty or endorsement thereof. Use of such information may require a license from a third party under the patents or other intellectual property of the third party, or a license from TI under the patents or other intellectual property of TI.

Reproduction of information in TI data books or data sheets is permissible only if reproduction is without alteration and is accompanied by all associated warranties, conditions, limitations, and notices. Reproduction of this information with alteration is an unfair and deceptive business practice. TI is not responsible or liable for such altered documentation.

Resale of TI products or services with statements different from or beyond the parameters stated by TI for that product or service voids all express and any implied warranties for the associated TI product or service and is an unfair and deceptive business practice. TI is not responsible or liable for any such statements.

Following are URLs where you can obtain information on other Texas Instruments products and application solutions:

Products		Applications	
Amplifiers	amplifier.ti.com	Audio	www.ti.com/audio
Data Converters	dataconverter.ti.com	Automotive	www.ti.com/automotive
DSP	dsp.ti.com	Broadband	www.ti.com/broadband
Interface	interface.ti.com	Digital Control	www.ti.com/digitalcontrol
Logic	logic.ti.com	Military	www.ti.com/military
Power Mgmt	power.ti.com	Optical Networking	www.ti.com/opticalnetwork
Microcontrollers	microcontroller.ti.com	Security	www.ti.com/security
		Telephony	www.ti.com/telephony
		Video & Imaging	www.ti.com/video
		Wireless	www.ti.com/wireless

Mailing Address: Texas Instruments
Post Office Box 655303 Dallas, Texas 75265