

VICOR CONFIDENTIAL  
 THIS DOCUMENT AND THE DATA DISCLOSED  
 HEREIN OR HEREWITH IS NOT TO BE REPRODUCED,  
 USED, OR DISCLOSED IN WHOLE OR IN PART  
 TO ANYONE WITHOUT PERMISSION OF VICOR CORP.

REV.	DESCRIPTION	DATE	APPROVED
01	DRN- E990450	RCM 3/13/00	DPK

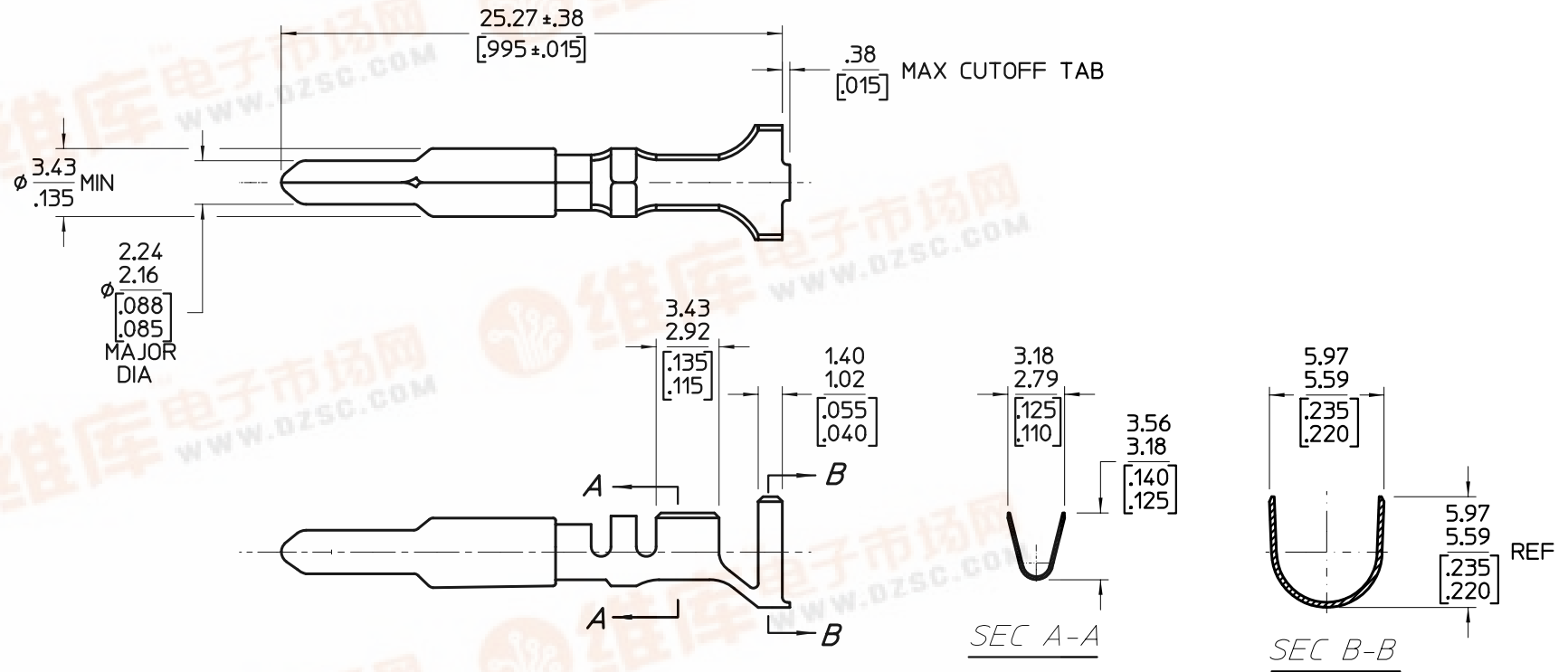

NOTES:

1. MATERIAL: 0.30 [.012] BRASS
2. FINISH: TIN PLATE 0.4-3.5 MICROMETERS THK.
3. WIRE RANGE: 0.5-2mm<sup>2</sup> [20-14 AWG]  
 INSULATION RANGE: 3.30-5.08 [.130-.200] DIA.
4. DIMENSIONS IN [BRACKETS] ARE IN INCHES.  
 SUGGESTED VENDOR: AMP PN 770248-1.

DRAWN BY <b>RCM</b>	DATE <b>3/13/00</b>				
UNLESS OTHERWISE SPECIFIED DIMENSIONS ARE IN MM/[INCHES] TOLERANCES ARE: DECIMALS      ANGLES .XXX± ±0.13/[.005]      ±1°					
THIRD ANGLE PROJECTION 		SIZE <b>B</b>	FSCM NO. <b>67131</b>	DWG NO. <b>20689</b>	REV <b>01</b>
DO NOT SCALE DRAWING		SCALE 4X	SHEET 1 OF 1		

