



24FC32

32K 5.0V 1 MHz I²C™ Smart Serial™ EEPROM

FEATURES

- Voltage operating range: 4.5V to 5.5V
 - Maximum write current 3 mA at 5.5V
 - Maximum read current 150 μ A at 5.5V
 - Standby current 1 μ A typical
- 1 MHz SE2.bus two wire protocol
- Self-timed write cycle (including auto-erase)
- Power on/off data protection circuitry
- Endurance:
 - 10,000,000 Erase/Write cycles guaranteed for a 4K block
 - 1,000,000 E/W cycles guaranteed for a 28K block
- 8-byte page, or byte modes available
- 1 page x 8 line input cache (64 bytes) for fast write loads
- Schmitt trigger inputs for noise suppression
- 2 ms typical write cycle time, byte or page
- Up to 8 chips may be connected to the same bus for up to 256K bits total memory
- Electrostatic discharge protection > 4000V
- Data retention > 200 years
- 8-pin PDIP/SOIC packages
- Temperature ranges
 - Commercial (C): 0°C to +70°C
 - Industrial (I): -40°C to +85°C

DESCRIPTION

The Microchip Technology Inc. 24FC32 is a 4K x 8 (32K bit) Serial Electrically Erasable PROM (EEPROM) with a high-speed 1 MHz SE2.bus whose protocol is functionally equivalent to the industry-standard I²C bus. This device has been developed for advanced, low power applications such as personal communications or data acquisition. The 24FC32 features an input cache for fast write loads with a capacity of eight 8-byte pages, or 64 bytes. It also features a fixed 4K-bit block of ultra-high endurance memory for data that changes frequently. The 24FC32 is capable of both random and sequential reads up to the 32K boundary. Functional address lines allow up to 8 - 24FC32 devices on the same bus, for up to 256K bits address space. The 24FC32 is available in the standard 8-pin plastic DIP and 8-pin surface mount SOIC package.

PACKAGE TYPES

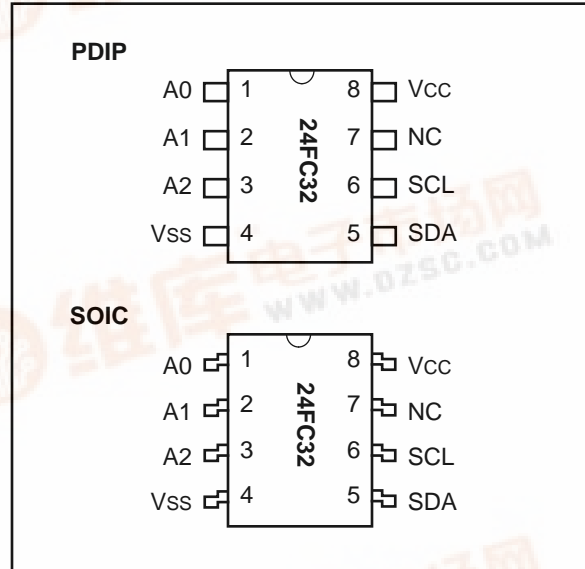

BLOCK DIAGRAM

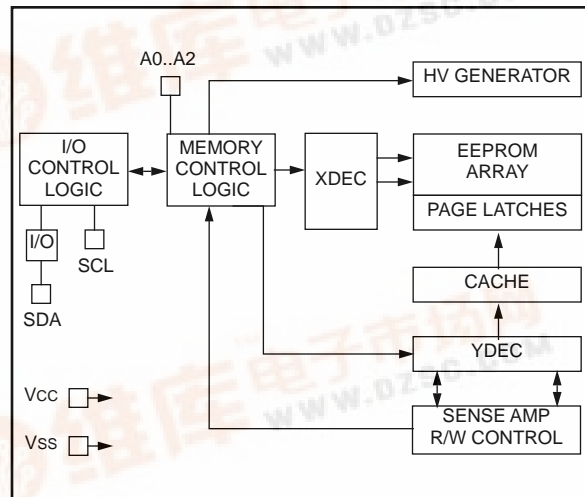

24FC32

1.0 ELECTRICAL CHARACTERISTICS

1.1 Maximum Ratings*

VCC7.0V
 All inputs and outputs w.r.t. VSS.....-0.6V to VCC +1.0V
 Storage temperature-65°C to +150°C
 Ambient temp. with power applied.....-65°C to +125°C
 Soldering temperature of leads (10 seconds) +300°C
 ESD protection on all pins≥ 4 kV

***Notice:** Stresses above those listed under “Maximum Ratings” may cause permanent damage to the device. This is a stress rating only and functional operation of the device at those or any other conditions above those indicated in the operational listings of this specification is not implied. Exposure to maximum rating conditions for extended periods may affect device reliability.

TABLE 1-1: PIN FUNCTION TABLE

| Name | Function |
|--------|--------------------------------|
| A0..A2 | User Configurable Chip Selects |
| VSS | Ground |
| SDA | Serial Address/Data I/O |
| SCL | Serial Clock |
| VCC | +4.5V to 5.5V Power Supply |
| NC | No Internal Connection |

TABLE 1-2: DC CHARACTERISTICS

| VCC = +4.5V to +5.5V Commercial (C): Tamb = 0°C to +70°C Industrial (I): Tamb = -40°C to +85°C | | | | | |
|--|---|----------------------|---------------------|----------|--|
| Parameter | Symbol | Min | Max | Units | Conditions |
| A0, A1, A2, SCL and SDA pins: | | | | | |
| High level input voltage | V _{IH} | 0.7 V _{CC} | — | V | |
| Low level input voltage | V _{IL} | — | 0.3 V _{CC} | V | |
| Hysteresis of SCL and SDA | V _{HYS} | 0.05 V _{CC} | — | V | (Note 1) |
| Low level output voltage of SDA | V _{OL} | — | 0.40 | V | I _{OL} = 3.0 mA |
| Input leakage current | I _{LI} | -10 | 10 | μA | V _{IN} = 0.1V TO V _{CC} |
| Output leakage current | I _{LO} | -10 | 10 | μA | V _{OUT} = 0.1V to V _{CC} |
| Pin capacitance (all inputs/outputs) | C _{INT} | — | 10 | pF | V _{CC} = 5.0V (Note 1) Tamb = 25°C, F _{clk} = 1 MHz |
| Operating current | I _{CC} WRITE I _{CC} Read | — | 3 150 | mA μA | V _{CC} = 5.5V, SCL = 1 MHz V _{CC} = 5.5V, SCL = 1 MHz |
| Standby current | I _{CCS} | — | 5 (1 typical) | μA | V _{CC} = 5.5V, SCL = SDA = V _{CC} (Note 1) |

Note 1: This parameter is periodically sampled and not 100% tested.

FIGURE 1-1: BUS TIMING START/STOP

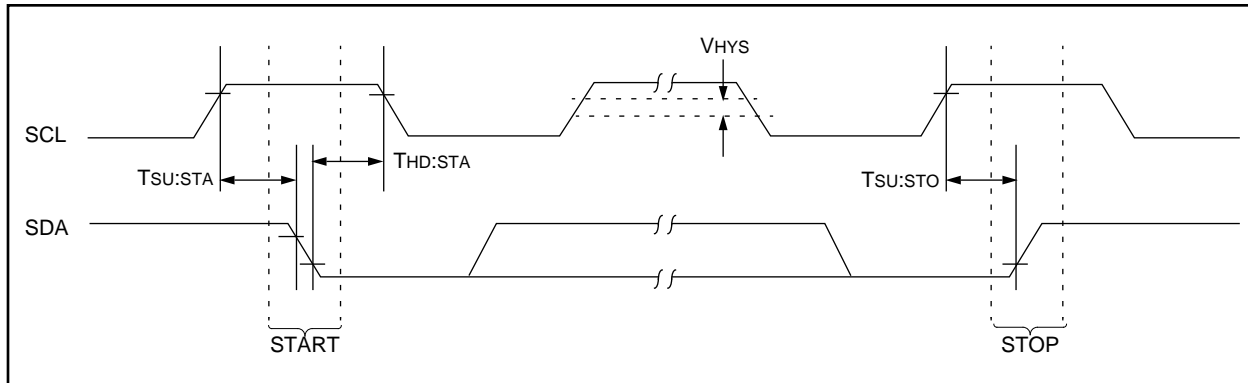

TABLE 1-3: AC CHARACTERISTICS

| Parameter | Symbol | 1 MHz Bus | | Units | Remarks |
|----------------------------|---------------------|-----------|------|---------|---|
| | | Min | Max | | |
| Clock frequency | FCLK | 0 | 1000 | kHz | |
| Clock high time | T _{HIGH} | 500 | — | ns | |
| Clock low time | T _{LOW} | 500 | — | ns | |
| SDA and SCL rise time | T _R | — | 300 | ns | (Note 1) |
| SDA and SCL fall time | T _F | — | 100 | ns | (Note 1) |
| START condition hold time | T _{HD:STA} | 250 | — | ns | After this period the first clock pulse is generated |
| START condition setup time | T _{SU:STA} | 250 | — | ns | Only relevant for repeated START condition |
| Data input hold time | T _{HD:DAT} | 0 | — | ns | |
| Data input setup time | T _{SU:DAT} | 100 | — | ns | |
| STOP condition setup time | T _{SU:STO} | 250 | — | ns | |
| Output valid from clock | T _{A A} | — | 350 | ns | (Note 2) |
| Bus free time | T _{B U F} | 500 | — | ns | Time the bus must be free before a new transmission can start |
| Write cycle time | T _{W R} | — | 5 | ms/page | Note 3 |
| Endurance | | | | | |
| High Endurance Block | — | 10M | — | 10M | 25°C, V _{cc} = 5.0V, Block Mode (Note 4) |
| Rest of Array | — | 1M | — | 1M | |

Note 1: Not 100 percent tested.

Note 2: As a transmitter, the device must provide an internal minimum delay time to bridge the undefined region (minimum 100 ns) of the falling edge of SCL to avoid unintended generation of START or STOP conditions.

Note 3: The times shown are for a single page of 8 bytes. Multiply by the number of pages loaded into the write cache for total time.

Note 4: This parameter is not tested but guaranteed by characterization. For endurance estimates in a specific application, please consult the Total Endurance Model which can be obtained on our BBS or website.

FIGURE 1-2: BUS TIMING DATA

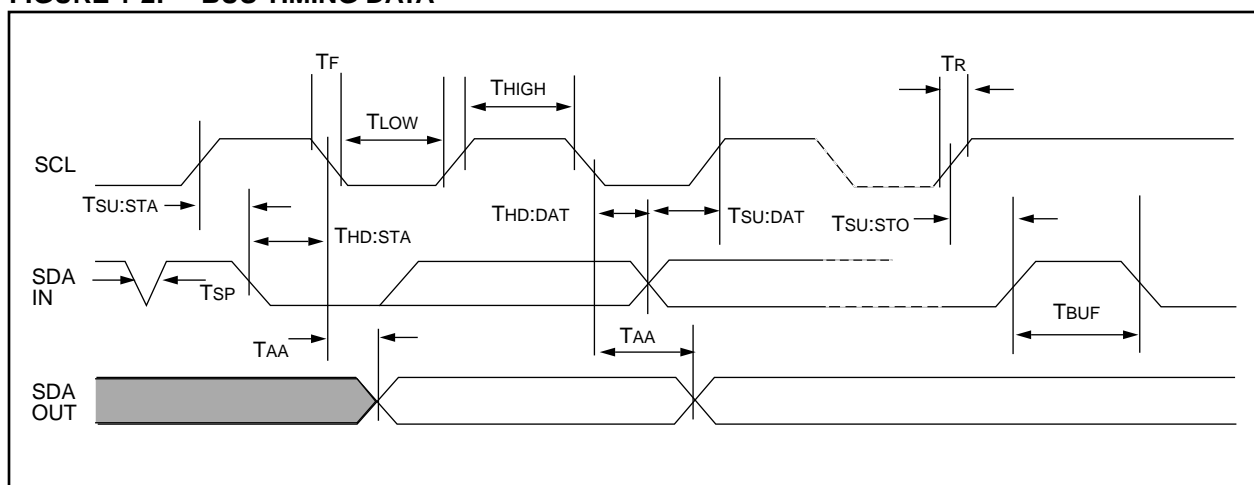

24FC32

2.0 FUNCTIONAL DESCRIPTION

The 24FC32 supports a bidirectional two-wire bus and data transmission protocol. A device that sends data onto the bus is defined as transmitter, and a device receiving data as receiver. The bus must be controlled by a master device which generates the serial clock (SCL), controls the bus access, and generates the START and STOP conditions, while the 24FC32 works as slave. Both master and slave can operate as transmitter or receiver but the master device determines which mode is activated.

3.0 BUS CHARACTERISTICS

The following **bus protocol** has been defined:

- Data transfer may be initiated only when the bus is not busy.
- During data transfer, the data line must remain stable whenever the clock line is HIGH. Changes in the data line while the clock line is HIGH will be interpreted as a START or STOP condition.

Accordingly, the following bus conditions have been defined (Figure 3-1).

3.1 Bus not Busy (A)

Both data and clock lines remain HIGH.

3.2 Start Data Transfer (B)

A HIGH to LOW transition of the SDA line while the clock (SCL) is HIGH determines a START condition. All commands must be preceded by a START condition.

3.3 Stop Data Transfer (C)

A LOW to HIGH transition of the SDA line while the clock (SCL) is HIGH determines a STOP condition. All operations must be ended with a STOP condition.

3.4 Data Valid (D)

The state of the data line represents valid data when, after a START condition, the data line is stable for the duration of the HIGH period of the clock signal.

The data on the line must be changed during the LOW period of the clock signal. There is one clock pulse per bit of data.

Each data transfer is initiated with a START condition and terminated with a STOP condition. The number of the data bytes transferred between the START and STOP conditions is determined by the master device.

3.5 Acknowledge

Each receiving device, when addressed, is obliged to generate an acknowledge signal after the reception of each byte. The master device must generate an extra clock pulse which is associated with this acknowledge bit.

Note: The 24FC32 does not generate any acknowledge bits if an internal programming cycle is in progress.

A device that acknowledges must pull down the SDA line during the acknowledge clock pulse in such a way that the SDA line is stable LOW during the HIGH period of the acknowledge related clock pulse. Of course, setup and hold times must be taken into account. During reads, a master must signal an end of data to the slave by NOT generating an acknowledge bit on the last byte that has been clocked out of the slave. In this case, the slave (24FC32) will leave the data line HIGH to enable the master to generate the STOP condition.

FIGURE 3-1: DATA TRANSFER SEQUENCE ON THE SERIAL BUS

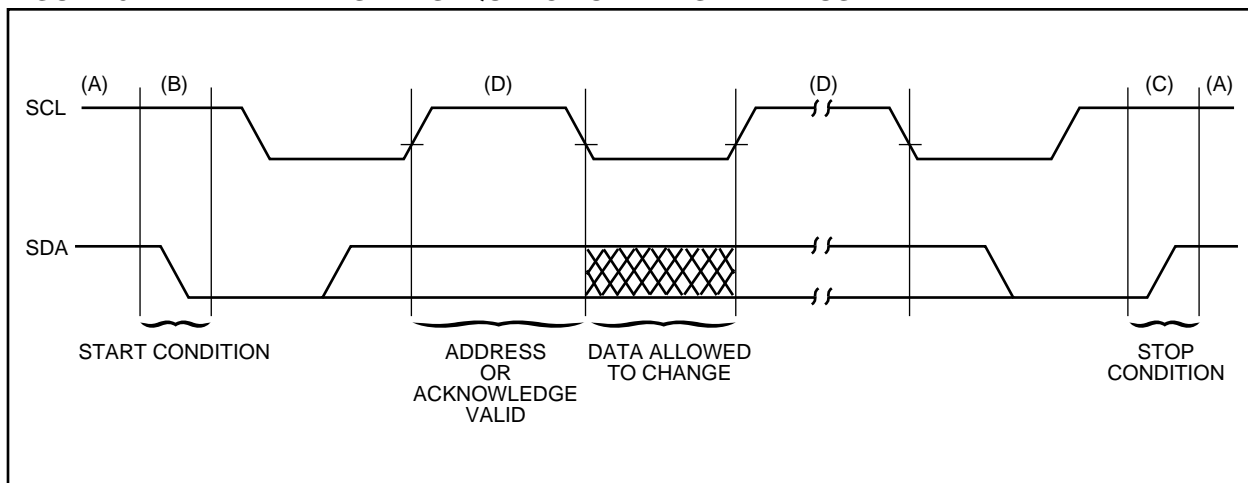

3.6 Device Addressing

A control byte is the first byte received following the start condition from the master device. The control byte consists of a four bit control code; for the 24FC32 this is set as 1010 binary for read and write operations. The next three bits of the control byte are the device select bits (A2, A1, A0). They are used by the master device to select which of the eight devices are to be accessed. These bits are in effect the three most significant bits of the word address. The last bit of the control byte (R/W) defines the operation to be performed. When set to a one a read operation is selected, and when set to a zero a write operation is selected. The next two bytes received define the address of the first data byte (Figure 3-3). Because only A11..A0 are used, the upper four address bits must be zeros. The most significant bit of the most significant byte of the address is transferred first. Following the start condition, the 24FC32 monitors the SDA bus checking the device type identifier being transmitted. Upon receiving a 1010 code and appropriate device select bits, the slave device outputs an acknowledge signal on the SDA line. Depending on the state of the R/W bit, the 24FC32 will select a read or write operation.

FIGURE 3-2: CONTROL BYTE ALLOCATION

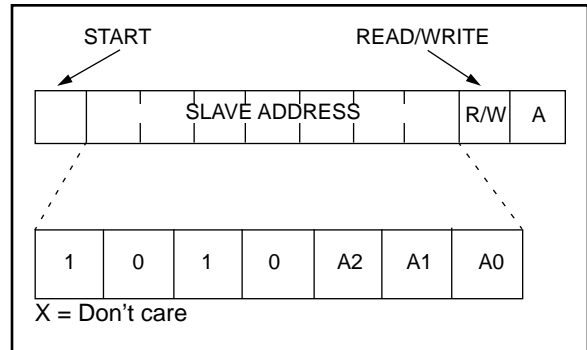

| Operation | Control Code | Device Select | R/W |
|-----------|--------------|----------------|-----|
| Read | 1010 | Device Address | 1 |
| Write | 1010 | Device Address | 0 |

FIGURE 3-3: ADDRESS SEQUENCE BIT ASSIGNMENTS

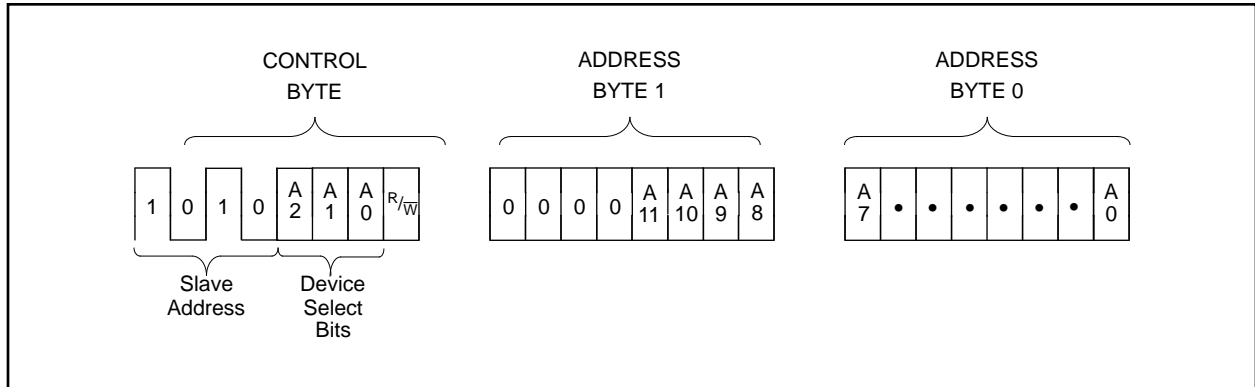

24FC32

4.0 WRITE OPERATION

4.1 Split Endurance

The 24FC32 is organized as a continuous 32K block of memory. However, the first 4K, starting at address 000, is rated at 10,000,000 E/W cycles guaranteed. The remainder of the array, 28K bits, is rated at 100K E/W cycles guaranteed. This feature is helpful in applications in which some data change frequently, while a majority of the data change infrequently. One example would be a cellular telephone in which last-number redial and microcontroller scratch pad require a high-endurance block, while speed dials and lookup tables change infrequently and so require only a standard endurance rating.

4.2 Byte Write

Following the start condition from the master, the control code (four bits), the device select (three bits), and the R/W bit which is a logic low are clocked onto the bus by the master transmitter. This indicates to the addressed slave receiver that a byte with a word address will follow after it has generated an acknowledge bit during the ninth clock cycle. Therefore the next byte transmitted by the master is the high-order byte of the word address and will be written into the address pointer of the 24FC32. The next byte is the least significant address byte. After receiving another acknowledge signal from the 24FC32 the master device will transmit the data word to be written into the addressed memory location. The 24FC32 acknowledges again and the master generates a stop condition. This initiates the internal write cycle, and during this time the 24FC32 will not generate acknowledge signals (Figure 4-1).

4.3 Page Write

The write control byte, word address and the first data byte are transmitted to the 24FC32 in the same way as in a byte write. But instead of generating a stop condition, the master transmits up to eight pages of eight data bytes each (64 bytes total) which are temporarily stored in the on-chip page cache of the 24FC32. They will be written from cache into the EEPROM array after the master has transmitted a stop condition. After the receipt of each word, the six lower order address pointer bits are internally incremented by one. The higher order seven bits of the word address remain constant. If the master should transmit more than eight bytes prior to generating the stop condition (writing across a page boundary), the address counter (lower three bits) will roll over and the pointer will be incremented to point to the next line in the cache. This can continue to occur up to eight times or until the cache is full, at which time a stop condition should be generated by the master. If a stop condition is not received, the cache pointer will roll over to the first line (byte 0) of the cache, and any further data received will overwrite previously captured data. The stop condition can be sent at any time during the transfer. As with the byte write operation, once a stop condition is received, an internal write cycle will begin. The 64-byte cache will continue to capture data until a stop condition occurs or the operation is aborted (Figure 4-2).

FIGURE 4-1: BYTE WRITE

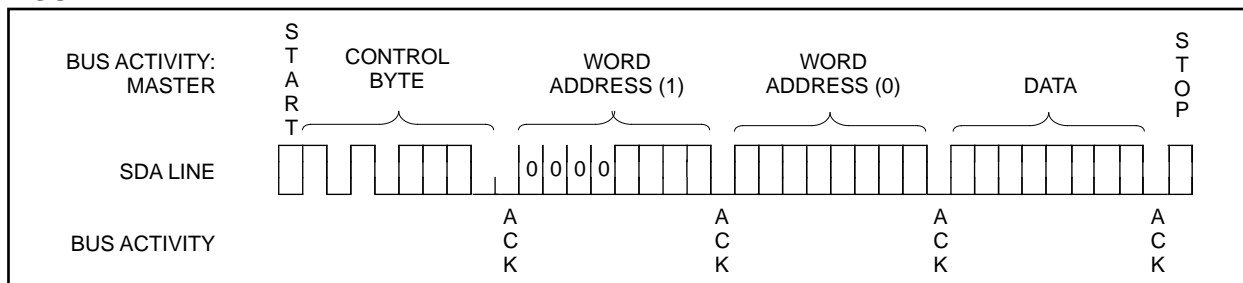
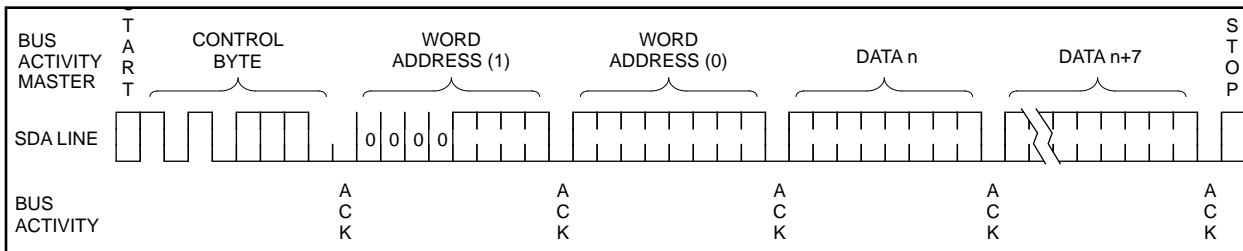

FIGURE 4-2: PAGE WRITE



5.0 ACKNOWLEDGE POLLING

Since the device will not acknowledge during a write cycle, this can be used to determine when the cycle is complete (this feature can be used to maximize bus throughput). Once the stop condition for a write command has been issued from the master, the device initiates the internally timed write cycle. ACK polling can be initiated immediately. This involves the master sending a start condition followed by the control byte for a write command ($R/\overline{W} = 0$). If the device is still busy with the write cycle, then no ACK will be returned. If the cycle is complete, then the device will return the ACK and the master can then proceed with the next read or write command. See Figure 5-1 for flow diagram.

FIGURE 5-1: ACKNOWLEDGE POLLING FLOW

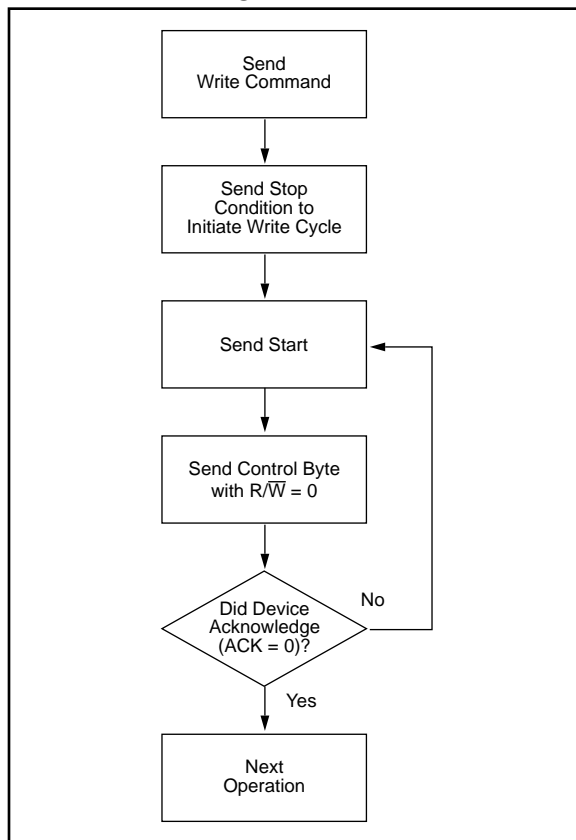

6.0 READ OPERATION

Read operations are initiated in the same way as write operations with the exception that the R/\overline{W} bit of the slave address is set to one. There are three basic types of read operations: current address read, random read, and sequential read.

6.1 Current Address Read

The 24FC32 contains an address counter that maintains the address of the last word accessed, internally incremented by one. Therefore, if the previous access (either a read or write operation) was to address n (n is any legal address), the next current address read operation would access data from address $n + 1$. Upon receipt of the slave address with R/\overline{W} bit set to one, the 24FC32 issues an acknowledge and transmits the eight bit data word. The master will not acknowledge the transfer but does generate a stop condition and the 24FC32 discontinues transmission (Figure 6-1).

6.2 Random Read

Random read operations allow the master to access any memory location in a random manner. To perform this type of read operation, first the word address must be set. This is done by sending the word address to the 24FC32 as part of a write operation (R/\overline{W} bit set to 0). After the word address is sent, the master generates a start condition following the acknowledge. This terminates the write operation, but not before the internal address pointer is set. Then the master issues the control byte again but with the R/\overline{W} bit set to a one. The 24FC32 will then issue an acknowledge and transmit the eight bit data word. The master will not acknowledge the transfer but does generate a stop condition which causes the 24FC32 to discontinue transmission (Figure 6-2).

FIGURE 6-1: CURRENT ADDRESS READ

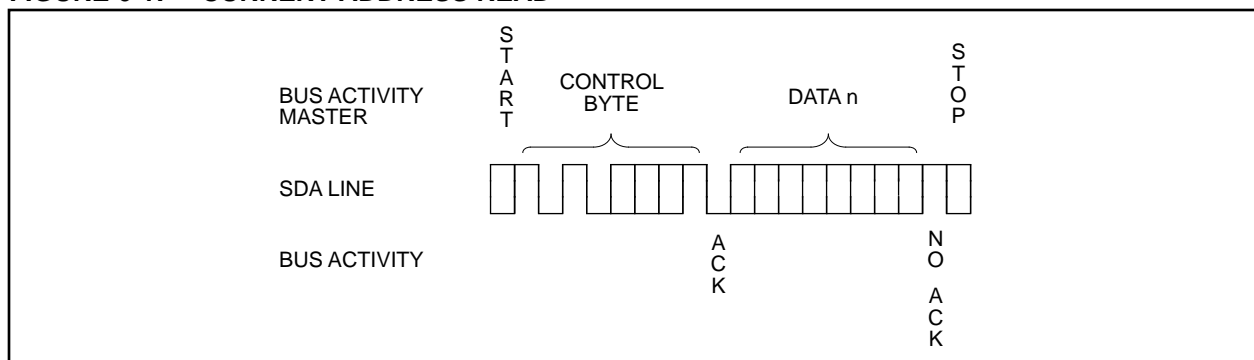

24FC32

6.3 Contiguous Addressing Across Multiple Devices

The device select bits A2, A1, A0 can be used to expand the contiguous address space for up to 256K bits by adding up to eight 24FC32's on the same bus. In this case, software can use A0 of the control byte as address bit A12, A1 as address bit A13, and A2 as address bit A14.

6.4 Sequential Read

Sequential reads are initiated in the same way as a random read except that after the 24FC32 transmits the first data byte, the master issues an acknowledge as opposed to the stop condition used in a random read. This acknowledge directs the 24FC32 to transmit the next sequentially addressed 8 bit word (Figure 6-3). Following the final byte transmitted to the master, the master will NOT generate an acknowledge but will generate a stop condition.

To provide sequential reads the 24FC32 contains an internal address pointer which is incremented by one at the completion of each operation. This address pointer allows the entire memory contents to be serially read during one operation. The address pointer, however, will not roll over from address 07FF to address 0000. It will roll from 07FF to unused memory space.

6.5 Noise Protection

The SCL and SDA inputs incorporate Schmitt triggers which suppress noise spikes to ensure proper device operation even on a noisy bus.

FIGURE 6-2: RANDOM READ

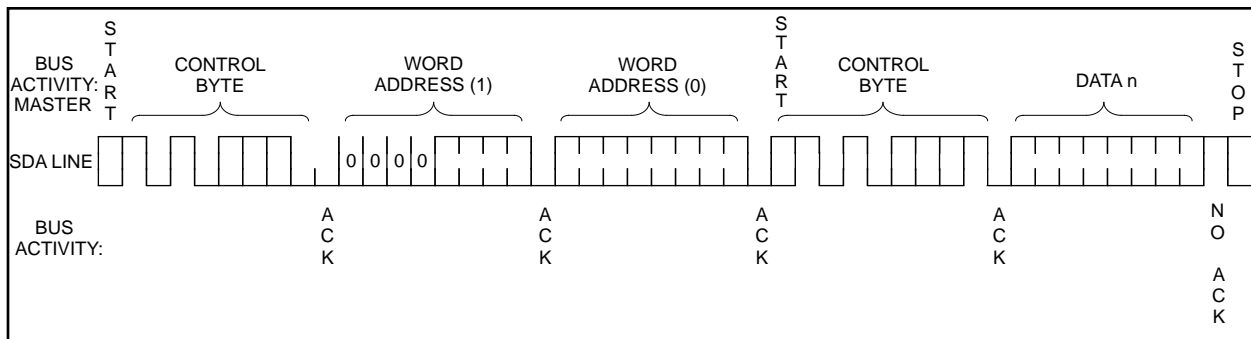
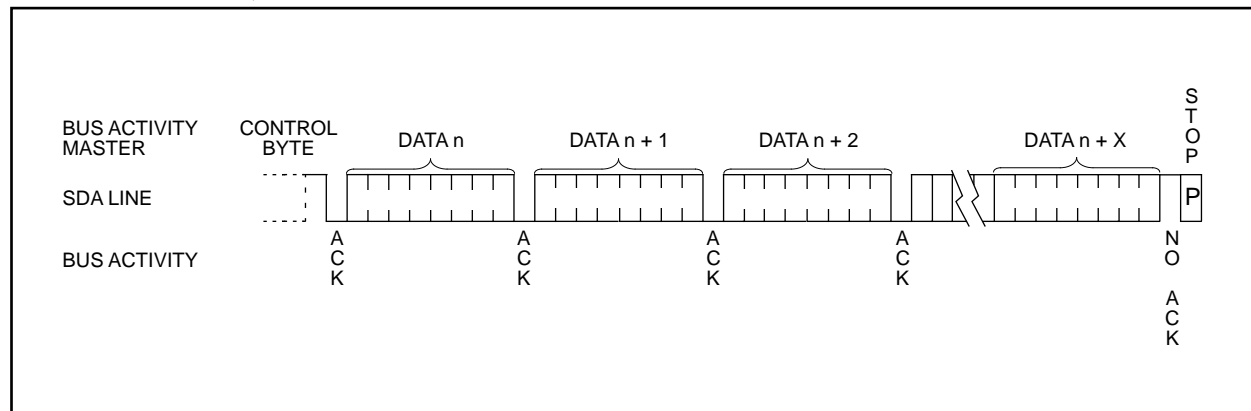

FIGURE 6-3: SEQUENTIAL READ



7.0 PAGE CACHE AND ARRAY MAPPING

The cache is a 64 byte (8 pages x 8 bytes) FIFO buffer. The cache allows the loading of up to 64 bytes of data before the write cycle is actually begun, effectively providing a 64-byte burst write at the maximum bus rate. Whenever a write command is initiated, the cache starts loading and will continue to load until a stop bit is received to start the internal write cycle. The total length of the write cycle will depend on how many pages are loaded into the cache before the stop bit is given. Maximum cycle time for each page is 5 ms. Even if a page is only partially loaded, it will still require the same cycle time as a full page. If more than 64 bytes of data are loaded before the stop bit is given, the address pointer will 'wrap around' to the beginning of cache page 0 and existing bytes in the cache will be overwritten. The device will not respond to any commands while the write cycle is in progress.

7.1 Cache Write Starting at a Page Boundary

If a write command begins at a page boundary (address bits A2, A1 and A0 are zero), then all data loaded into the cache will be written to the array in sequential addresses. This includes writing across a 4K block boundary. In the example shown below, (Figure 7-1) a write command is initiated starting at byte 0 of page 3 with a fully loaded cache (64 bytes). The first byte in the cache is written to byte 0 of page 3 (of the array), with the remaining pages in the cache written to sequential pages in the array. A write cycle is executed after each page is written. Since the write begins at page 3 and 8 pages are loaded into the cache, the last 3 pages of the cache are written to the next row in the array.

7.2 Cache Write Starting at a Non-Page Boundary

When a write command is initiated that does not begin at a page boundary (i.e., address bits A2, A1 and A0 are not all zero), it is important to note how the data is loaded into the cache, and how the data in the cache is written to the array. When a write command begins, the first byte loaded into the cache is always loaded into page 0. The byte within page 0 of the cache where the load begins is determined by the three least significant address bits (A2, A1, A0) that were sent as part of the write command. If the write command does not start at byte 0 of a page and the cache is fully loaded, then the last byte(s) loaded into the cache will roll around to page 0 of the cache and fill the remaining empty bytes. If more than 64 bytes of data are loaded into the cache, data already loaded will be overwritten. In the example shown in Figure 7-2, a write command has been initiated starting at byte 2 of page 3 in the array with a fully loaded cache of 64 bytes. Since the cache started loading at byte 2, the last two bytes loaded into the cache will 'roll over' and be loaded into the first two bytes of page 0 (of the cache). When the stop bit is sent, page 0 of the cache is written to page 3 of the array. The remaining pages in the cache are then loaded sequentially to the array. A write cycle is executed after each page is written. If a partially loaded page in the cache remains when the STOP bit is sent, only the bytes that have been loaded will be written to the array.

7.3 Power Management

This design incorporates a power standby mode when the device is not in use and automatically powers off after the normal termination of any operation when a stop bit is received and all internal functions are complete. This includes any error conditions, ie. not receiving an acknowledge or stop condition per the two-wire bus specification. The device also incorporates V_{DD} monitor circuitry to prevent inadvertent writes (data corruption) during low-voltage conditions. The V_{DD} monitor circuitry is powered off when the device is in standby mode in order to further reduce power consumption.

24FC32

FIGURE 7-1: CACHE WRITE TO THE ARRAY STARTING AT A PAGE BOUNDARY

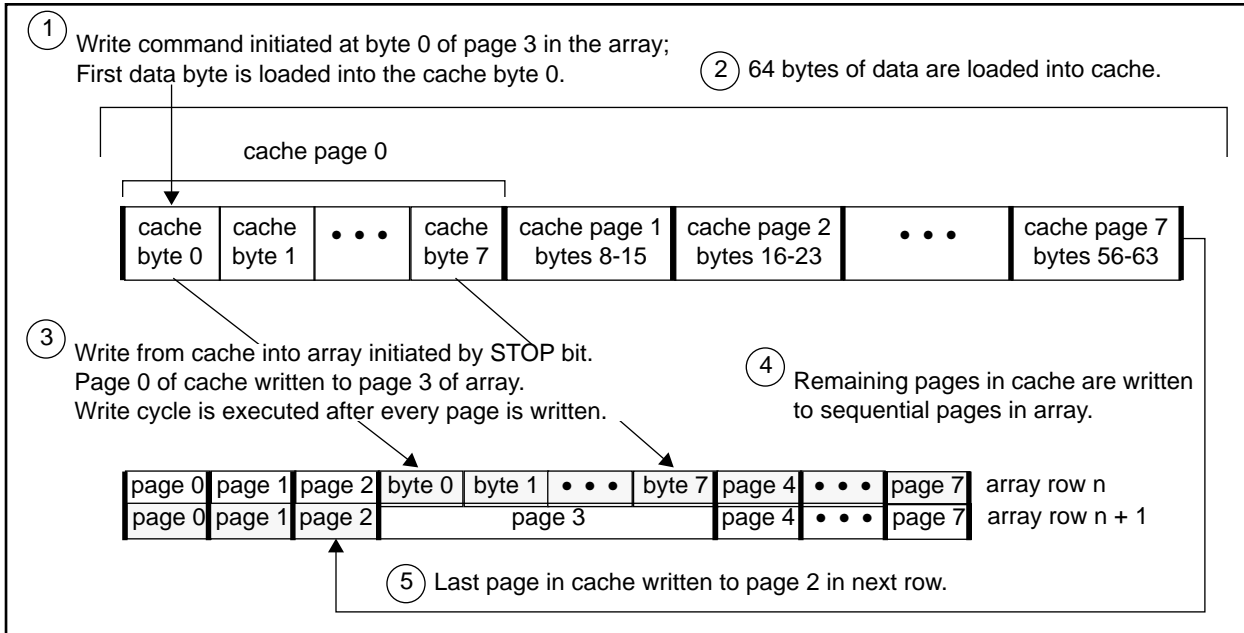
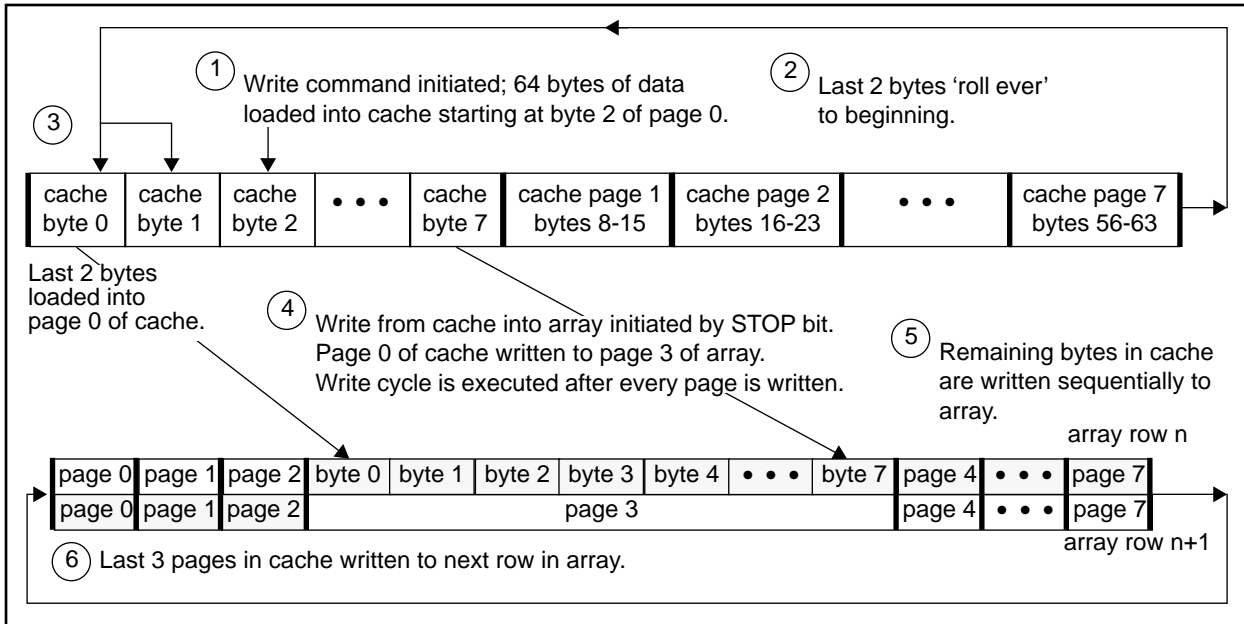

FIGURE 7-2: CACHE WRITE TO THE ARRAY STARTING AT A NON-PAGE BOUNDARY



8.0 PIN DESCRIPTIONS

8.1 A0, A1, A2 Chip Address Inputs

The A0..A2 inputs are used by the 24FC32 for multiple device operation and conform to the two-wire bus standard. The levels applied to these pins define the address block occupied by the device in the address map. A particular device is selected by transmitting the corresponding bits (A2, A1, A0) in the control byte (Figure 3-3).

8.2 SDA Serial Address/Data Input/Output

This is a bidirectional pin used to transfer addresses and data into and data out of the device. It is an open drain terminal, therefore the SDA bus requires a pullup resistor to Vcc (typical 1K Ω , must consider total bus capacitance and maximum rise/fall times).

For normal data transfer SDA is allowed to change only during SCL low. Changes during SCL high are reserved for indicating the START and STOP conditions.

8.3 SCL Serial Clock

This input is used to synchronize the data transfer from and to the device.

24FC32

24FC32 Product Identification System

To order or to obtain information (e.g., on pricing or delivery), please use the listed part numbers, and refer to the factory or the listed sales offices.

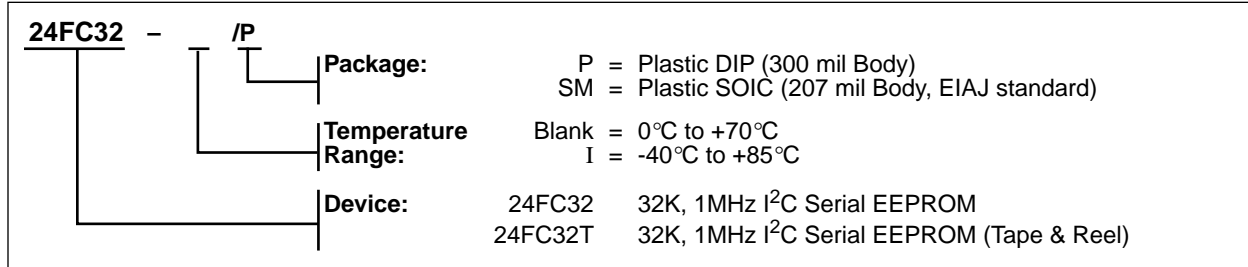

AMERICAS

Corporate Office

Microchip Technology Inc.
2355 West Chandler Blvd.
Chandler, AZ 85224-6199
Tel: 602 786-7200 Fax: 602 786-7277
Technical Support: 602 786-7627
Web: <http://www.microchip.com>

Atlanta

Microchip Technology Inc.
500 Sugar Mill Road, Suite 200B
Atlanta, GA 30350
Tel: 770 640-0034 Fax: 770 640-0307

Boston

Microchip Technology Inc.
5 Mount Royal Avenue
Marlborough, MA 01752
Tel: 508 480-9990 Fax: 508 480-8575

Chicago

Microchip Technology Inc.
333 Pierce Road, Suite 180
Itasca, IL 60143
Tel: 708 285-0071 Fax: 708 285-0075

Dallas

Microchip Technology Inc.
14651 Dallas Parkway, Suite 816
Dallas, TX 75240-8809
Tel: 972 991-7177 Fax: 972 991-8588

Dayton

Microchip Technology Inc.
Suite 150
Two Prestige Place
Miamisburg, OH 45342
Tel: 513 291-1654 Fax: 513 291-9175

Los Angeles

Microchip Technology Inc.
18201 Von Karman, Suite 1090
Irvine, CA 92612
Tel: 714 263-1888 Fax: 714 263-1338

New York

Microchip Technmgy Inc.
150 Motor Parkway, Suite 416
Hauppauge, NY 11788
Tel: 516 273-5305 Fax: 516 273-5335

San Jose

Microchip Technology Inc.
2107 North First Street, Suite 590
San Jose, CA 95131
Tel: 408 436-7950 Fax: 408 436-7955

AMERICAS (CONT)

Toronto

Microchip Technology Inc.
5925 Airport Road, Suite 200
Mississauga, Ontario L4V 1W1, Canada
Tel: 905 405-6279 Fax: 905 405-6253

ASIA/PACIFIC

China

Microchip Technology
Unit 406 of Shanghai Golden Bridge Bldg.
2077 Yan'an Road West, Hongjiao District
Shanghai, Peoples Republic of China
Tel: 86 21 6275 5700
Fax: 011 86 21 6275 5060

Hong Kong

Microchip Technology
RM 3801B, Tower Two
Metroplaza
223 Hing Fong Road
Kwai Fong, N.T. Hong Kong
Tel: 852 2 401 1200 Fax: 852 2 401 3431

India

Microchip Technology
No. 6, Legacy, Convent Road
Bangalore 560 025 India
Tel: 91 80 526 3148 Fax: 91 80 559 9840

Korea

Microchip Technology
168-1, Youngbo Bldg. 3 Floor
Samsung-Dong, Kangnam-Ku,
Seoul, Korea
Tel: 82 2 554 7200 Fax: 82 2 558 5934

Singapore

Microchip Technology
200 Middle Road
#10-03 Prime Centre
Singapore 188980
Tel: 65 334 8870 Fax: 65 334 8850

Taiwan, R.O.C

Microchip Technology
10F-1C 207
Tung Hua North Road
Taipei, Taiwan, ROC
Tel: 886 2 717 7175 Fax: 886 2 545 0139

EUROPE

United Kingdom

Arizona Microchip Technology Ltd.
Unit 6, The Courtyard
Meadow Bank, Furlong Road
Bourne End, Buckinghamshire SL8 5AJ
Tel: 44 1628 850303 Fax: 44 1628 850178

France

Arizona Microchip Technology SARL
Zone Industrielle de la Bonde
2 Rue du Buisson aux Fraises
91300 Massy - France
Tel: 33 1 69 53 63 20 Fax: 33 1 69 30 90 79

Germany

Arizona Microchip Technology GmbH
Gustav-Heinemann-Ring 125
D-81739 Muenchen, Germany
Tel: 49 89 627 144 0 Fax: 49 89 627 144 44

Italy

Arizona Microchip Technology SRL
Centro Direzionale Colleone Pas Taurus 1
Viale Colleoni 1
20041 Agrate Brianza
Milan Italy
Tel: 39 39 6899939 Fax: 39 39 689 9883

JAPAN

Microchip Technology Intl. Inc.
Benex S-1 6F
3-18-20, Shin Yokohama
Kohoku-Ku, Yokohama
Kanagawa 222 Japan
Tel: 81 45 471 6166 Fax: 81 45 471 6122

9/3/96



MICROCHIP

All rights reserved.

Printed on recycled paper.

© 1996, Microchip Technology Incorporated

Information contained in this publication regarding device applications and the like is intended through suggestion only and may be superseded by updates. No representation or warranty is given and no liability is assumed by Microchip Technology Incorporated with respect to the accuracy or use of such information, or infringement of patents or other intellectual property rights arising from such use or otherwise. Use of Microchip's products as critical components in life support systems is not authorized except with express written approval by Microchip. No licenses are conveyed, implicitly or otherwise, under any intellectual property rights. The Microchip logo and name are registered trademarks of Microchip Technology Inc. All rights reserved. All other trademarks mentioned herein are the property of their respective companies.