

International  
**IR** Rectifier

SCHOTTKY RECTIFIER  
HIGH EFFICIENCY SERIES

PD -20354D

25GQ045

35A, 45V

Major Ratings and Characteristics

Characteristics	25GQ045	Units
$I_{F(AV)}$	35	A
$V_{RRM}$	45	V
$I_{FSM}$ @ $t_p = 8.3ms$ half-sine	400	A
$V_F$ @ $35A_{pk}, T_J = 125^\circ C$	0.84	V
$T_J, T_{stg}$ Operating and storage	-55 to 150	$^\circ C$

Description/Features

The 25GQ045 Schottky rectifier has been expressly designed to meet the rigorous requirements of hi-rel environments. It is packaged in the hermetic isolated TO-254AA package. The device's forward voltage drop and reverse leakage current are optimized for the lowest power loss and the highest circuit efficiency for typical high frequency switching power supplies and resonant power converters. Full MIL-PRF-19500 quality conformance testing is available on source controlled drawings to TX, TXV and S levels.

- Hermetically Sealed
- Low Forward Voltage Drop
- High Frequency Operation
- Guard Ring for Enhanced Ruggedness and Long Term Reliability
- Electrically Isolated

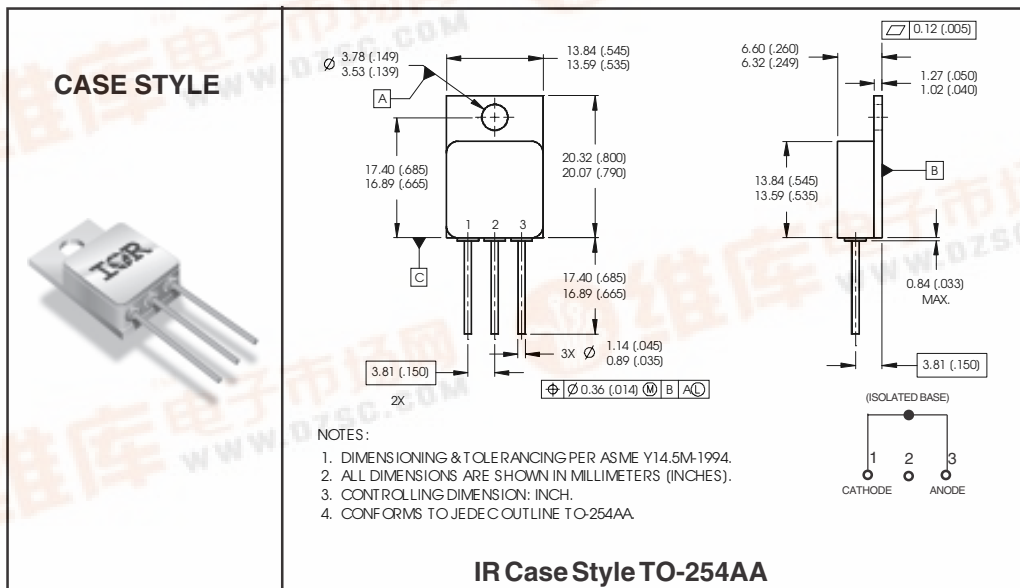

25GQ045

International  
IOR Rectifier**Voltage Ratings**

Part number	25GQ045
V <sub>R</sub> Max. DC Reverse Voltage (V)	45
V <sub>RWM</sub> Max. Working Peak Reverse Voltage (V)	

**Absolute Maximum Ratings**

Parameters	Limits	Units	Conditions
I <sub>F(AV)</sub> Max. Average Forward Current See Fig. 5	35	A	50% duty cycle @ T <sub>C</sub> = 100°C, square waveform
I <sub>FSM</sub> Max. Peak One Cycle Non - Repetitive Surge Current	400	A	@ t <sub>p</sub> = 8.3 ms half-sine

**Electrical Specifications**

Parameters	Limits	Units	Conditions
V <sub>FM</sub> Max. Forward Voltage Drop See Fig. 1 ①	0.93	V	@ 35A T <sub>J</sub> = 25°C
	1.38	V	@ 70A
	0.84	V	@ 35A T <sub>J</sub> = 125°C
	1.29	V	@ 70A
I <sub>RM</sub> Max. Reverse Leakage Current See Fig. 2 ①	0.8	mA	T <sub>J</sub> = 25°C V <sub>R</sub> = rated V <sub>R</sub>
	45	mA	T <sub>J</sub> = 125°C
C <sub>T</sub> Max. Junction Capacitance	2600	pF	V <sub>R</sub> = 5V <sub>DC</sub> ( 1MHz, 25°C )
L <sub>S</sub> Typical Series Inductance	7.8	nH	Measured from anode lead to cathode lead 6mm ( 0.025 in.) from package

**Thermal-Mechanical Specifications**

Parameters	Limits	Units	Conditions
T <sub>J</sub> Max. Junction Temperature Range	-55 to 150	°C	
T <sub>stg</sub> Max. Storage Temperature Range	-55 to 150	°C	
R <sub>thJC</sub> Max. Thermal Resistance, Junction to Case	1.0	°C/W	DC operation See Fig. 4
wt Weight (Typical)	9.3	g	
Die Size (Typical)	200X200	mils	
Case Style	TO-254AA		

① Pulse Width &lt; 300μs, Duty Cycle &lt; 2%

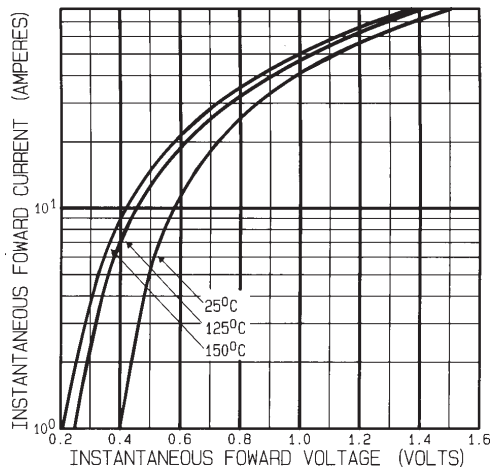

Fig. 1 - Max. Forward Voltage Drop Characteristics

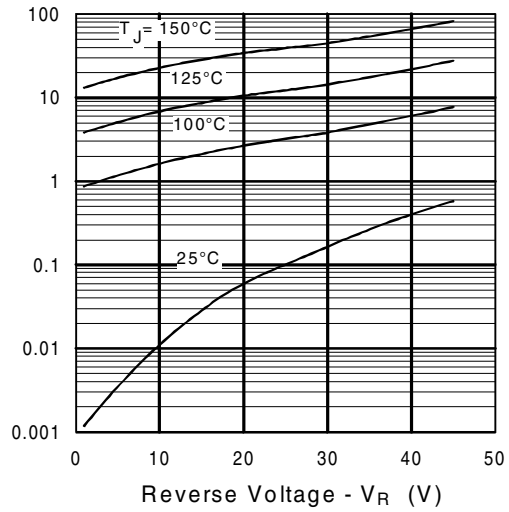

Fig. 2 - Typical Values of Reverse Current Vs. Reverse Voltage

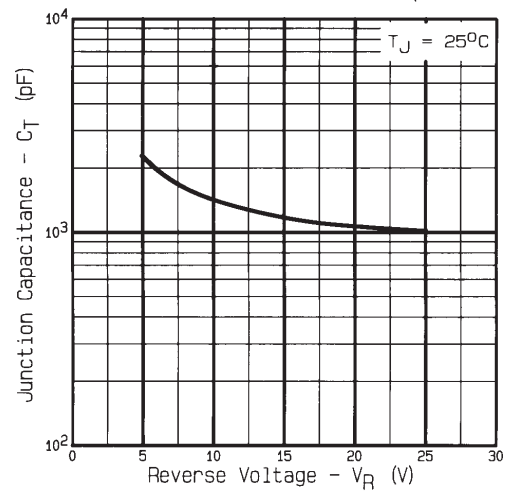

Fig. 3 - Typical Junction Capacitance Vs. Reverse Voltage

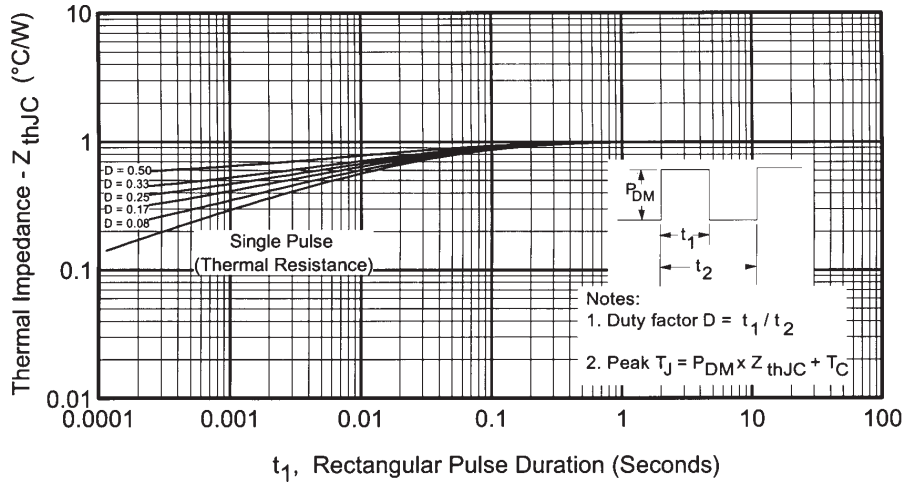

Fig. 4 - Max. Thermal Impedance  $Z_{thJC}$  Characteristics

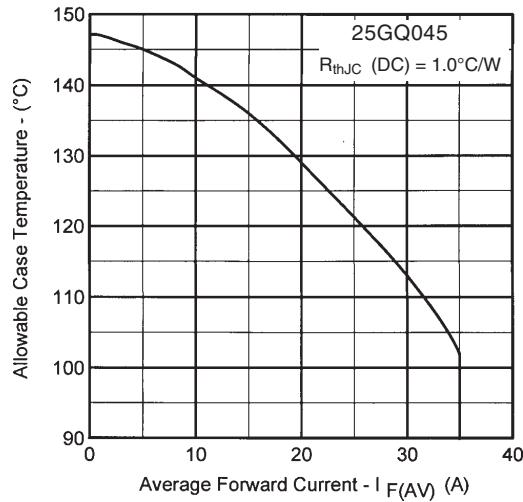

Fig. 5 - Max. Allowable Case Temperature Vs. Average Forward Current