



# NJM2700

PRELIMINARY



## SRS WOW AUDIO PROCESSOR

### ■GENERAL DESCRIPTION

The **NJM2700** is a SRS WOW audio processor, based on the technology of SRS Labs, Inc.

The **NJM2700** reproduces wide and clear sound. In addition, it provides rich bass sound.

The **NJM2700** is suitable for speaker system for personal computer, TV, CD radio-cassette, portable audio equipment, and others.

### ■PACKAGE OUTLINE

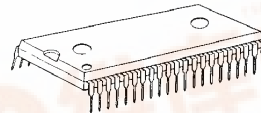

NJM2700L



NJM2700G



NJM2700FJ1

### ■FEATURES

- Operating Voltage 4.7 to 13V
- WOW Function
- Punch Control for TruBass effect
- Width Control for SRS 3D Stereo effect
- Bypass Function (Through)
- Internal Mode Switch
- Bipolar Technology
- Package Outline SDIP42, SOP40, QFP48

The WOW technology right incorporated in the **NJM2700** are owned by SRS Labs, a U.S. Corporation and licensed to New Japan Radio Co., Ltd. WOW is protected under U.S. and foreign patents issued and/or pending. WOW and the , are trademarks of SRS Labs, Inc. in the United States and selected foreign countries. Neither the purchase of the **NJM2700**, nor the corresponding sale of audio enhancement equipment conveys the right to sell commercialized recordings made with any SRS technology.

SRS Labs requires that all users of the **NJM2700** must enter into a license agreement directly with SRS Labs if the royalty is not included in the purchase price. SRS Labs also requires any users to comply with all rules and regulations as outlined in the SRS Trademark Usage Manual.

For further information, please contact:

SRS Labs, Inc.  
 2909 Daimler Street. Santa Ana, CA 92705 USA  
 Tel:914-442-1070 Fax:914-852-1099 <http://www.srslabs.com>



# NJM2700

## ■PIN FUNCTION (SDIP42)

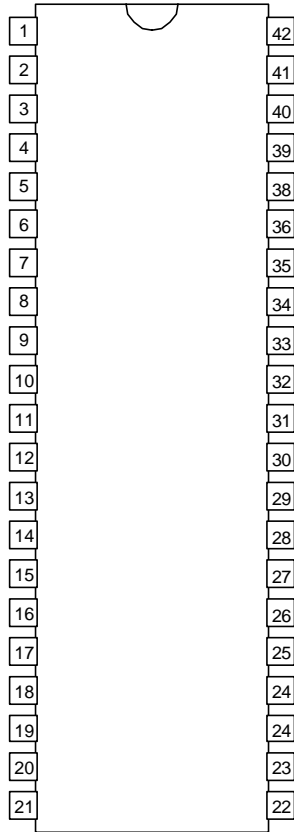

- |           |            |             |
|-----------|------------|-------------|
| 1. C3     | 15. C2     | 29. BASSOUT |
| 2. C4     | 16. SFIL1  | 30. OUTR    |
| 3. FILOUT | 17. SFIL2  | 31. OUTL    |
| 4. FIL1   | 18. SFIL3  | 32. TP3     |
| 5. FIL2   | 19. SVOL2  | 33. FFR4    |
| 6. FIL3   | 20. SVOL1  | 34. FFR3    |
| 7. FIL4   | 21. GND    | 35. FFR2    |
| 8. FIL5   | 22. V+     | 36. FFR1    |
| 9. FIL6   | 23. VREFIN | 37. FFL4    |
| 10. FIL7  | 24. VREF   | 38. FFL3    |
| 11. TP1   | 25. MODE3  | 39. FFL2    |
| 12. PCOUT | 26. MODE2  | 40. FFL1    |
| 13. PCIN  | 27. MODE1  | 41. INR     |
| 14. C1    | 28. TP2    | 42. INL     |

## ■PIN FUNCTION (SOP40)

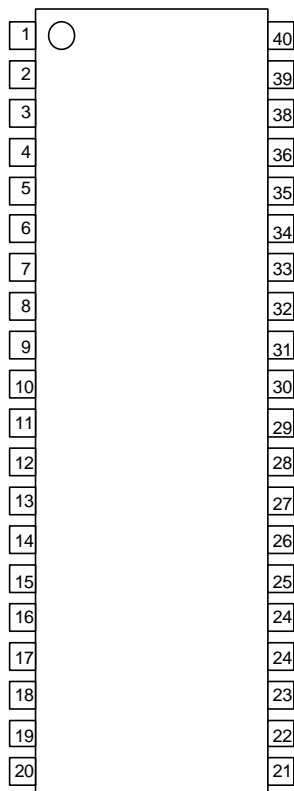

- |           |             |          |
|-----------|-------------|----------|
| 1. C3     | 15. SEL1    | 29. OUTR |
| 2. C4     | 16. SFIL2   | 30. OUTL |
| 3. FILOUT | 17. SFIL3   | 31. FFR4 |
| 4. FIL1   | 18. SVOL2   | 32. FFR3 |
| 5. FIL2   | 19. SVOL1   | 33. FFR2 |
| 6. FIL3   | 20. GND     | 34. FFR1 |
| 7. FIL4   | 21. V+      | 35. FFL4 |
| 8. FIL5   | 22. VREFIN  | 36. FFL3 |
| 9. FIL6   | 23. VREF    | 37. FFL2 |
| 10. FIL7  | 24. MODE3   | 38. FFL1 |
| 11. PCOUT | 25. MODE2   | 39. INR  |
| 12. PCIN  | 26. MODE2   | 40. INL  |
| 13. C1    | 27. TP2     |          |
| 14. C2    | 28. BASSOUT |          |

## ■PIN FUNCTION (QFP48)

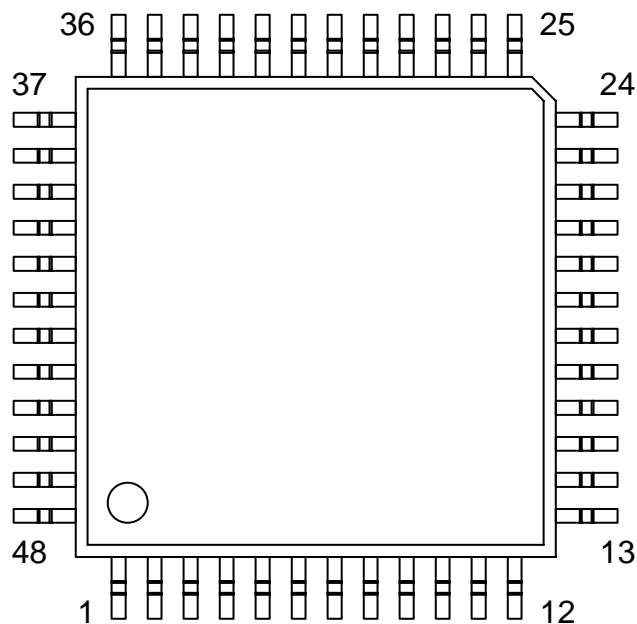

1. NC	17. SVOL1	33. FFR2
2. FIL3	18. GND	34. FFR1
3. FIL4	19. V+	35. FFL4
4. FIL5	20. VREFIN	36. NC
5. FIL6	21. VREF	37. NC
6. FIL7	22. MODE3	38. FFL3
7. PCOUT	23. MODE2	39. FFL2
8. PCIN	24. NC	40. FFL1
9. C1	25. NC	41. INR
10. C2	26. MODE1	42. INL
11. SFIL2	27. TP2	43. C3
12. NC	28. BASSOUT	44. C4
13. NC	29. OUTR	45. FILOUT
14. SFIL2	30. OUTL	46. FIL1
15. SFIL3	31. FFR4	47. FIL2
16. SVOL2	32. FFR3	48. NC

# NJM2700

## ■BLOCK DIAGRAM (SDIP42)

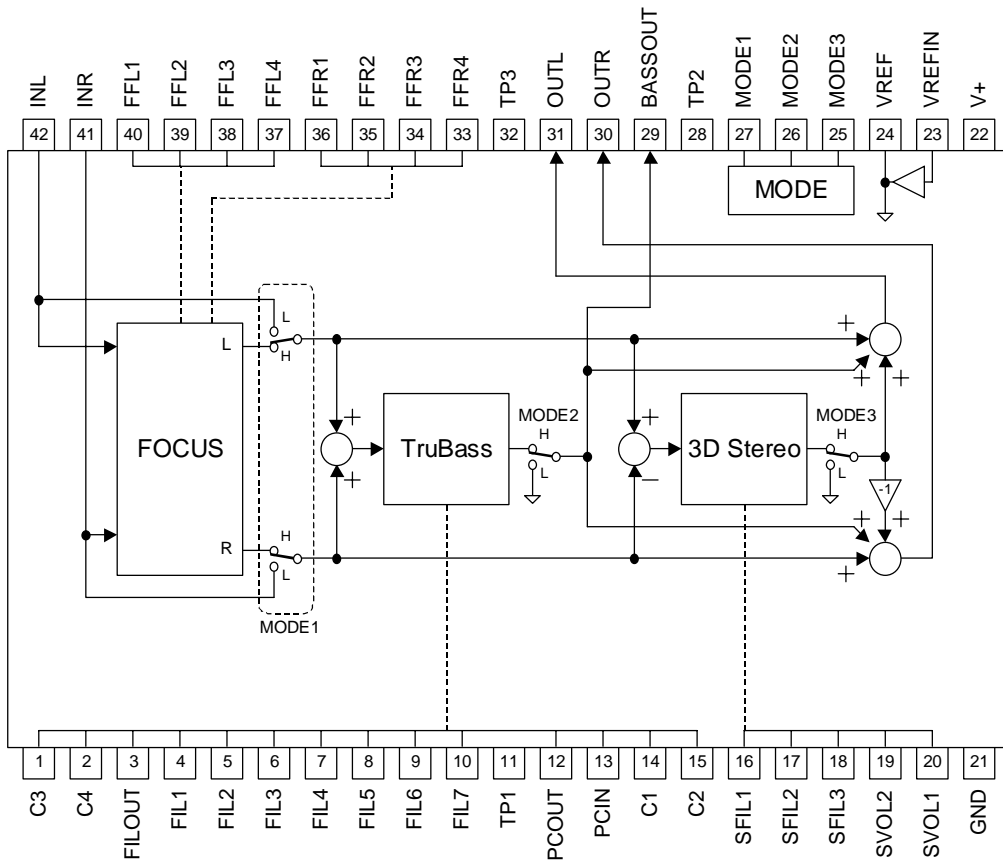

## ■BLOCK DIAGRAM (SOP40)

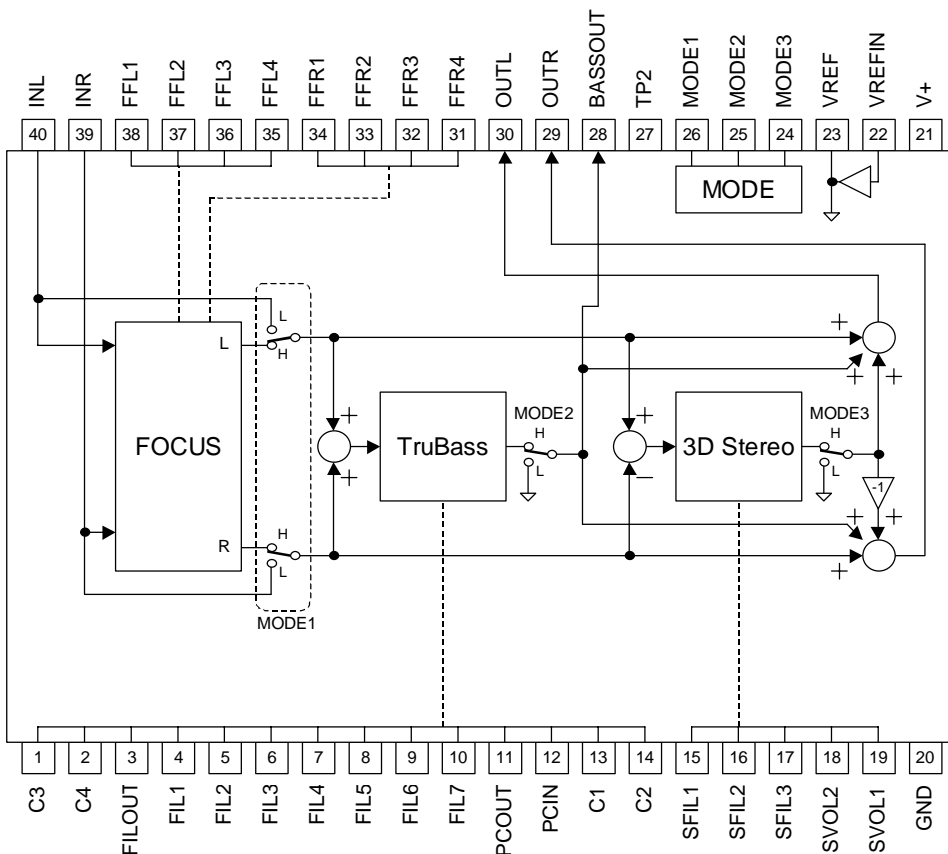

## ■BLOCK DIAGRAM (QFP48)

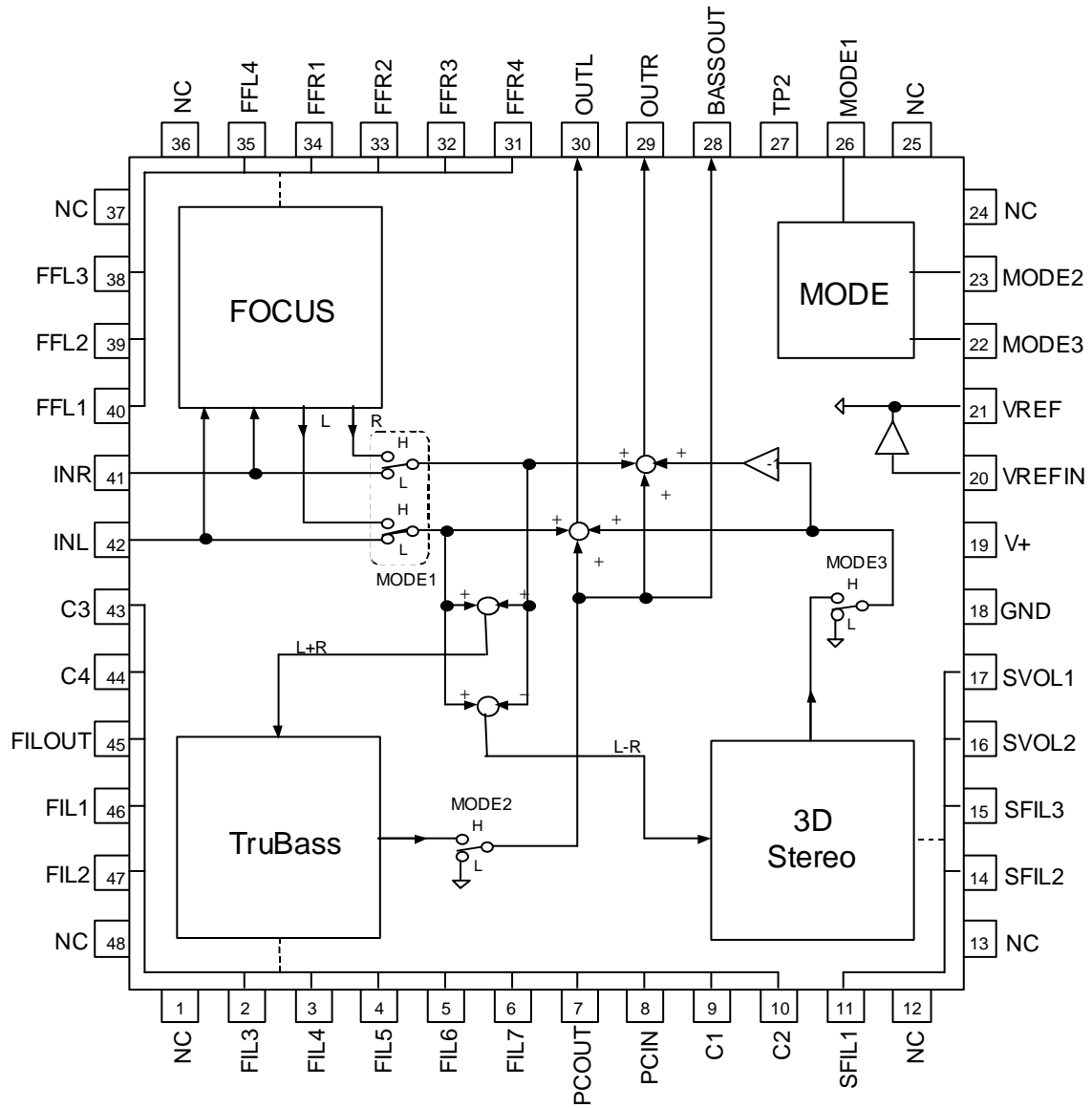

# NJM2700

## ■ABSOLUTE MAXIMUM RATING (Ta=25°C)

PARAMETER	SYMBOL	RATING	UNIT
Supply Voltage	V <sup>+</sup>	15	V
Power Dissipation	P <sub>D</sub>	(SDIP42) 700 (SOP40) 700 (QFP48) 450	mW
Operating Temperature Range	T <sub>opr</sub>	-40 to +85	°C
Storage Temperature Range	T <sub>stg</sub>	-40 to +125	°C

## ■ELECTRICAL CHARACTERISTICS ( V<sup>+</sup>=12V, Ta=25°C, V<sub>IN</sub>=-20dBV (=0.1Vrms), Speaker Size :Medium)

PARAMETER	SYMBOL	TEST CONDITION							MIN	TYP	MAX	UNIT	
		INPUT		OUTPUT	MODE	PUNCH VR	WIDTH VR	L					R
		L	R										
Operating Voltage	V <sup>+</sup>		-	-	-	-	-	-	4.7	12.0	13.0	V	
Operating Current	I <sub>CC</sub>	No Signal	-	-	-	BYPASS	-	-	8.7	17.4	26.1	mA	
			-	-	-	WOW	-	-	8.7	17.4	26.1		
Reference Voltage	V <sub>REF</sub>	V <sup>+</sup> /2	-	-	-	-	-	-	5.8	6.0	6.2	V	
Maximum Input Voltage	V <sub>IM</sub>	f=1kHz THD=3%	V <sub>IN</sub> -	- V <sub>IN</sub>	L R	BYPASS	-	-	10.0 (32)	12.0 (40)	-	dBV (Vrms)	
		f=100Hz THD=3%	V <sub>IN</sub> V <sub>IN</sub>	V <sub>IN</sub> V <sub>IN</sub>	L R	TruBass	MAX	-	-	-2.7 (0.73)	-		
		f=125Hz THD=3%	V <sub>IN</sub> -	- V <sub>IN</sub>	L R	3D-STEREO	-	MAX	-	0.5 (1.1)	-		
		f=125Hz THD=3%	V <sub>IN</sub> V <sub>IN</sub>	-V <sub>IN</sub> -V <sub>IN</sub>	L R	3D-STEREO	-	MAX	-	-5.5 (0.53)	-		
		f=10kHz THD=3%	V <sub>IN</sub> -	- V <sub>IN</sub>	L R	WOW	MAX	MAX	-5.8 (0.51)	-3.8 (0.65)	-		
		f=100Hz THD=3%	V <sub>IN</sub> V <sub>IN</sub>	V <sub>IN</sub> V <sub>IN</sub>	L R	WOW	MAX	MAX	-5.0 (0.56)	-3.0 (0.71)	-		
		f=10kHz THD=3%	V <sub>IN</sub> V <sub>IN</sub>	-V <sub>IN</sub> -V <sub>IN</sub>	L R	WOW	MAX	MAX	-10.9 (0.29)	-8.9 (0.36)	-		
Output Noise	V <sub>NO</sub>	Rg=0Ω A-Weighted	0	0	L R	BYPASS	-	-	-	-110 (3)	-100 (10)	dBV (μVrms)	
		Rg=0Ω A-Weighted	0	0	L R	TruBass	MAX	-	-	-80 (100)	-		
		Rg=0Ω A-Weighted	0	0	L R	3D-STEREO	-	MAX	-	-95 (18)	-		
		Rg=0Ω A-Weighted	0	0	L R	WOW	MAX	MAX	-	-80 (100)	-75 (180)		

**■ELECTRICAL CHARACTERISTICS** (  $V^+=12V$ ,  $T_a=25^\circ C$ ,  $V_{IN}=-20dBV$  ( $=0.1V_{rms}$ ), Speaker Size :Medium)

PARAMETER	SYMBOL	TEST CONDITION							MIN	TYP	MAX	UNIT
		INPUT		OUTPUT	MODE	PUNCH VR	WIDTH VR					
		L	R									
Total Harmonic Distortion	THD	f=1kHz	$V_{IN}$ -	- $V_{IN}$	L R	BYPASS	-	-	-	0.005	0.01	%
		f=100Hz	$V_{IN}$ $V_{IN}$	$V_{IN}$ $V_{IN}$	L R	TruBass	MAX	-	-	0.1	-	
		f=1kHz	$V_{IIN}$ -	- $V_{IN}$	L R	3D-STEREO	-	MAX	-	0.1	-	
		f=1kHz	$V_{IN}$ -	- $V_{IN}$	L R	WOW	MAX	MAX	-	0.1	1.0	
BYPASS Gain	$G_{VBYP}$	f=1kHz	$V_{IN}$ -	- $V_{IN}$	L R	BYPASS	-	-	-1.0	0.0	1.0	dB
SRS Gain	$G_{SRS}$	f=100Hz	$V_{IN}$ $V_{IN}$	$V_{IN}$ $V_{IN}$	L R	TruBass	MAX	-	12.8	14.8	16.8	dB
		f=100Hz	$V_{IN}$ $V_{IN}$	$V_{IN}$ $V_{IN}$	L R	TruBass	MIN	-	-2.3	1.7	5.7	
		f=125Hz	$V_{IN}$ -	- $V_{IN}$	L R	3D-STEREO	-	MAX	9.4	11.4	13.4	
		f=125Hz	$V_{IN}$ -	- $V_{IN}$	L R	3D-STEREO	-	MIN	-1.5	0.5	2.5	
		f=100Hz	$V_{IN}$ -	- $V_{IN}$	L R	WOW	MAX	MAX	13.8	15.8	17.8	
		f=10kHz	$V_{IN}$ -	- $V_{IN}$	L R	WOW	MAX	MAX	13.9	15.9	17.9	
MODE Select Control Voltage	$V_{MODE}$	$V_{IN}$ =High Level							2.0	-	$V^+$	V
		$V_{IN}$ =Low Level							0.0	-	0.7	

**■MODE SELECT FUNCTION**

MODE	MODE1	MODE2	MODE3
BYPASS	L	L	L
TruBass	L	H	L
3D-STEREO	L	L	H
WOW	H	H	H

# NJM2700

## ■PIN DESCRIPTION

No.		SYMBOL	FUNCTION	EQUIVALENT CIRCUIT	VOLTAGE
SDIP42	SOP40				
1 13 34 38	1 12 32 36	C3 PCIN FFR3 FFR1	Filter PUNCH Control VR Filter Filter		V+/2
2 5 19	2 5 18	C4 FIL2 SVOL2	Filter Filter WIDTH Control VR		V+/2
3 24 29 30 31 36 40	3 23 28 29 30 34 38	FILOUT VREF BASSOUT OUTR OUTL FFR1 FFL1	Filter Reference Voltage Output TruBass Output Rch Output Lch Output Filter Filter		V+/2
4	4	FIL1	Filter		V+/2



## ■PIN DESCRIPTION

No.		SYMBOL	FUNCTION	EQUIVALENT CIRCUIT	VOLTAGE
SDIP42	SOP40				
6	6	FIL3	Filter		V+/2
7	7	FIL4	Filter		
9	9	FIL5	Filter		
12	11	PCOUT	PUNCH Control VR		
20	19	SVOL1	WIDTH Control VR		
33	31	FFR4	Filter		
37	35	FFL4	Filter		
8	8	FIL5	Filter		V+/2
10	10	FIL7	Filter		
11	-	TP1	Test Pin		-
28	27	TP2	Test Pin		
32	-	TP3	Test Pin		
14	13	C1	Filter		0V

# NJM2700

## ■PIN DESCRIPTION

No.		SYMBOL	FUNCTION	EQUIVALENT CIRCUIT	VOLTAGE
SDIP42	SOP40				
15	14	C2	Filter		0V
16 17 18	15 16 17	SFIL1 SFIL2 SFIL3	Filter Filter Filter		V+/2
21	20	GND	GND		0V
22	21	V+	Power Supply		V+

## PIN DESCRIPTION

No.		SYMBOL	FUNCTION	EQUIVALENT CIRCUIT	VOLTAGE
SDIP42	SOP40				
23	22	VREFIN	Reference Voltage Input		$V+/2$
25 26 27	24 25 26	MODE3 MODE2 MODE1	Mode3 SW Mode2 SW Mode1 SW		0V
35 39	33 37	FFR2 FFL2	Filter Filter		$V+/2$
41 42	39 40	INR INL	Rch Input Lch Input		$V+/2$

# NJM2700

## APPLICATION CIRCUIT (SDIP42)

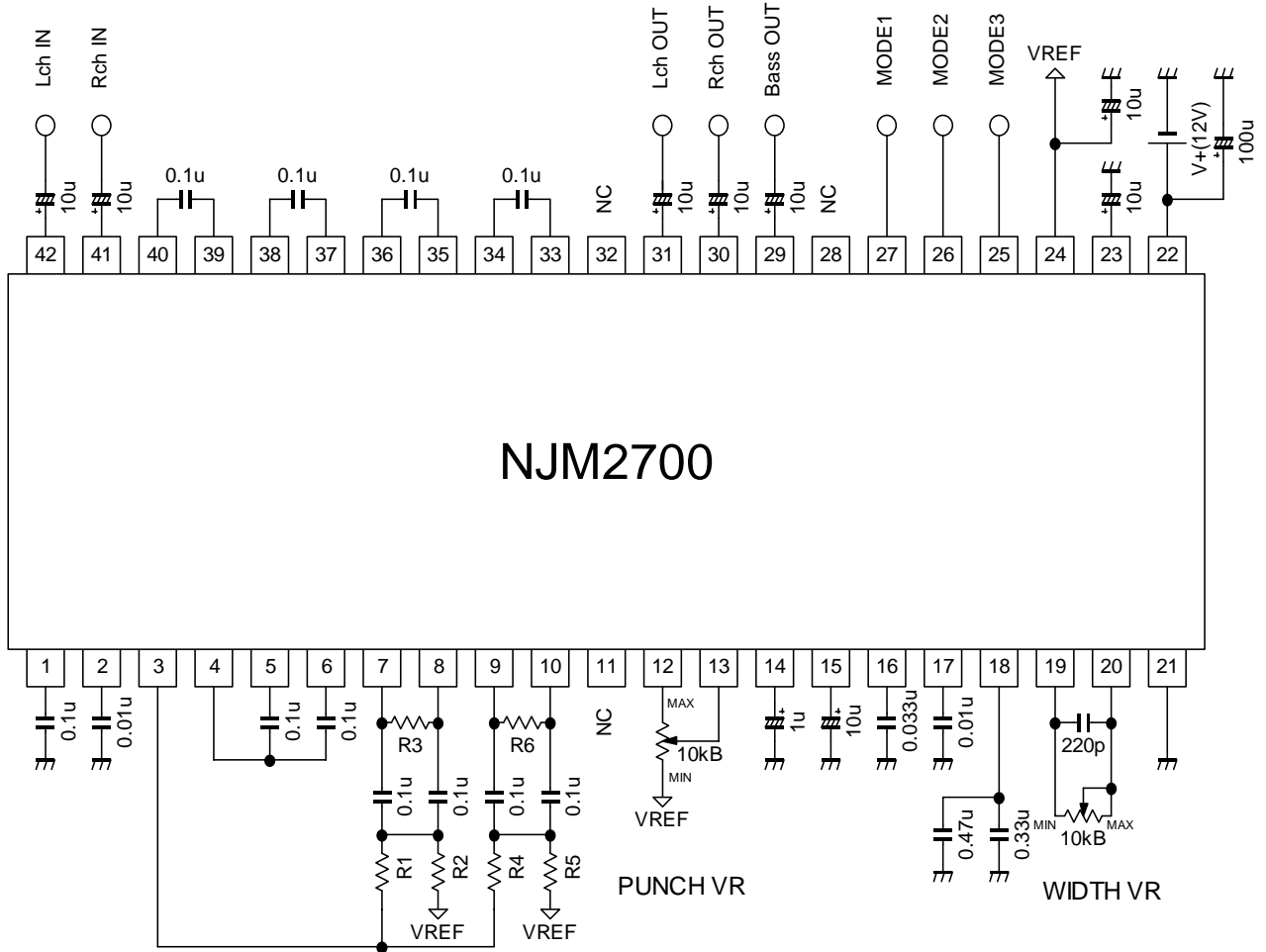

	SPEAKER SIZE		
	LARGE	MEDIUM	SMALL (TruBass mode only)
R1	56.2k	21k	21k
R2	13k	3.09k	3.09k
R3	158k	42k	42k
R4	37.4k	37.4k	22.1k
R5	8.87k	8.87k	2.32k
R6	107k	107k	32k

The standard setting of speaker size is as follows.(Reference)

- Large Mode :  $f_o \leq 80\text{Hz}$
- Medium Mode :  $80\text{Hz} < f_o \leq 150\text{Hz}$
- Small Mode :  $150\text{Hz} < f_o \leq 250\text{Hz}$

# NJM2700

## APPLICATION CIRCUIT (SOP40)

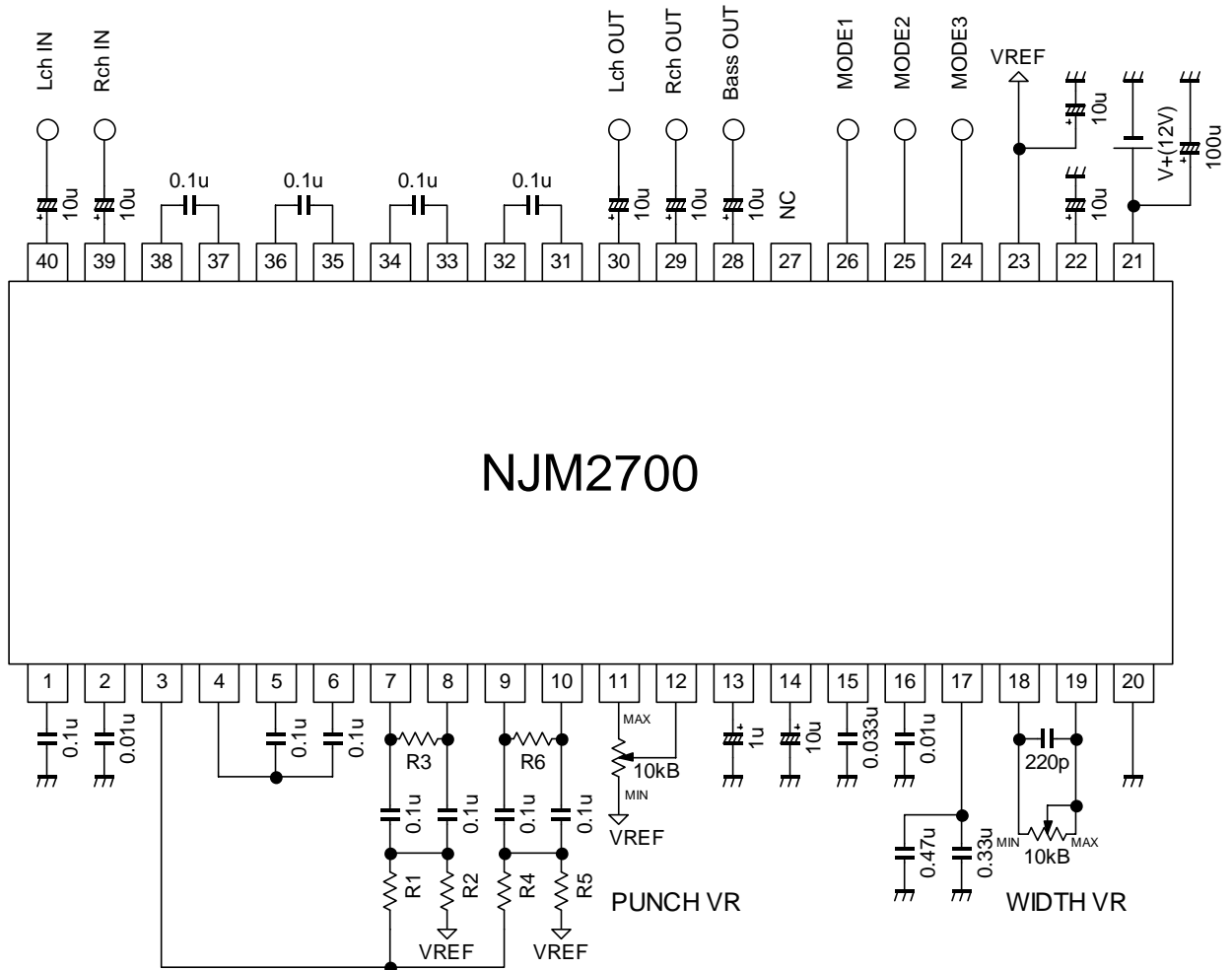

	SPEAKER SIZE		
	LARGE	MEDIUM	SMALL (TruBass mode only)
R1	56.2k	21k	21k
R2	13k	3.09k	3.09k
R3	158k	42k	42k
R4	37.4k	37.4k	22.1k
R5	8.87k	8.87k	2.32k
R6	107k	107k	32k

The standard setting of speaker size is as follows.(Reference)

- Large Mode :  $f_0 \leq 80\text{Hz}$
- Medium Mode :  $80\text{Hz} < f_0 \leq 150\text{Hz}$
- Small Mode :  $150\text{Hz} < f_0 \leq 250\text{Hz}$

# NJM2700

## APPLICATION CIRCUIT (QFP48)

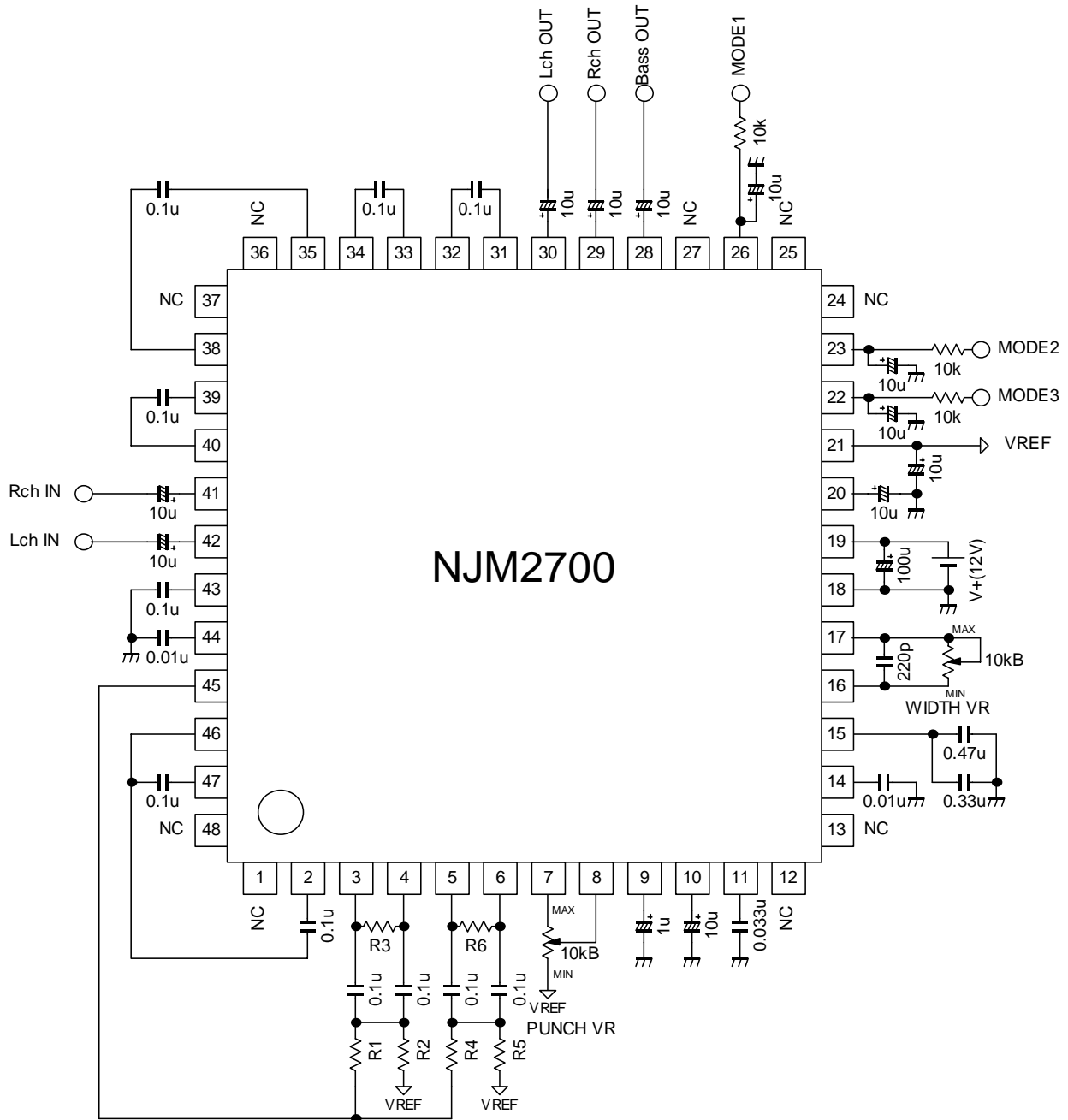

	SPEAKER SIZE		
	LARGE	MEDIUM	SMALL (TruBass mode only)
R1	56.2k	21k	21k
R2	13k	3.09k	3.09k
R3	158k	42k	42k
R4	37.4k	37.4k	22.1k
R5	8.87k	8.87k	2.32k
R6	107k	107k	32k

The standard setting of speaker size is as follows.(Reference)

- Large Mode :  $f_o \leq 80\text{Hz}$
- Medium Mode :  $80\text{Hz} < f_o \leq 150\text{Hz}$
- Small Mode :  $150\text{Hz} < f_o \leq 250\text{Hz}$

## APPLICATION CIRCUIT 2 (SDIP42)

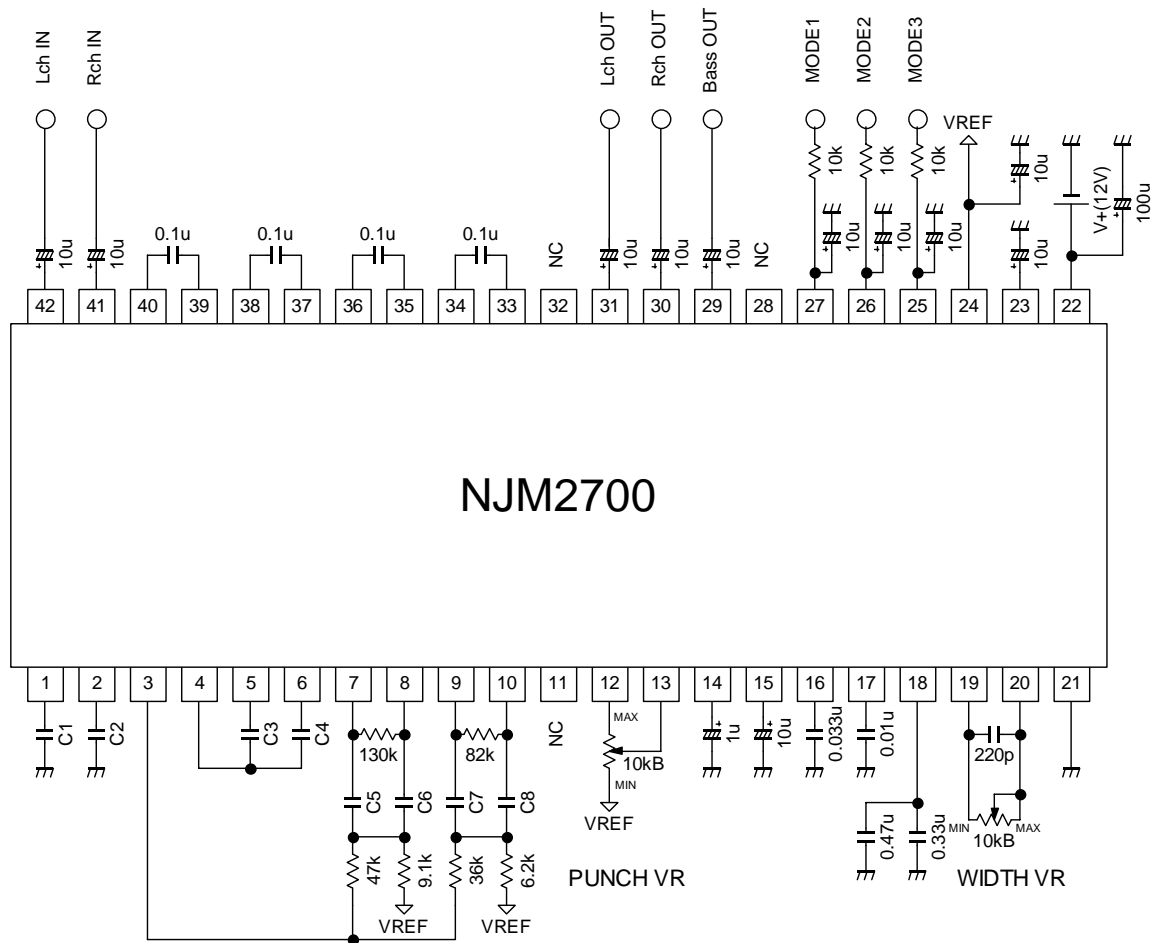

	C1	C2	C3 to C8
40Hz Setting	0.22	0.022	0.12
60Hz Setting	0.15	0.015	0.082
100Hz Setting	0.1	0.01	0.047
150Hz Setting	0.068	0.0068	0.033
200Hz Setting	0.047	0.0047	0.027
250Hz Setting	0.039	0.0039	0.022
300Hz Setting	0.033	0.0033	0.018
400Hz Setting	0.022	0.0022	0.012

Unit:  $\mu\text{F}$

### •Speaker Size Setting

Choose speaker size in accordance with  $f_0$  of the speaker.  
 (EX.) In the case of  $f_0 = 250\text{Hz}$ : 250Hz Setting.  
 Decide it after you confirm effect with the actual application.

# NJM2700

## APPLICATION CIRCUIT 2 (SOP40)

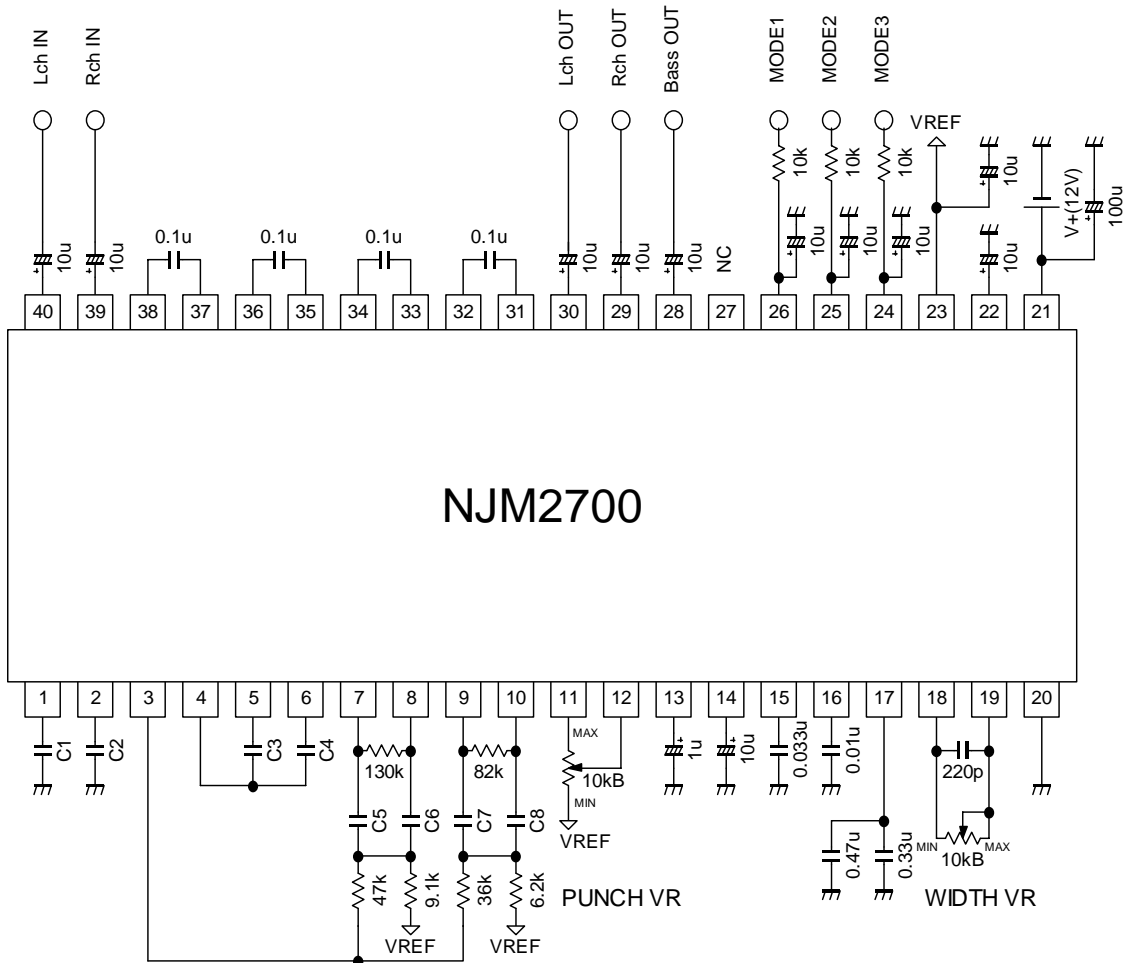

	C1	C2	C3 to C8
40Hz Setting	0.22	0.022	0.12
60Hz Setting	0.15	0.015	0.082
100Hz Setting	0.1	0.01	0.047
150Hz Setting	0.068	0.0068	0.033
200Hz Setting	0.047	0.0047	0.027
250Hz Setting	0.039	0.0039	0.022
300Hz Setting	0.033	0.0033	0.018
400Hz Setting	0.022	0.0022	0.012

Unit:  $\mu\text{F}$

### •Speaker Size Setting

Choose speaker size in accordance with  $f_0$  of the speaker.  
 (EX.) In the case of  $f_0 = 250\text{Hz}$ : 250Hz Setting.  
 Decide it after you confirm effect with the actual application.



## APPLICATION CIRCUIT 2 (QFP48)

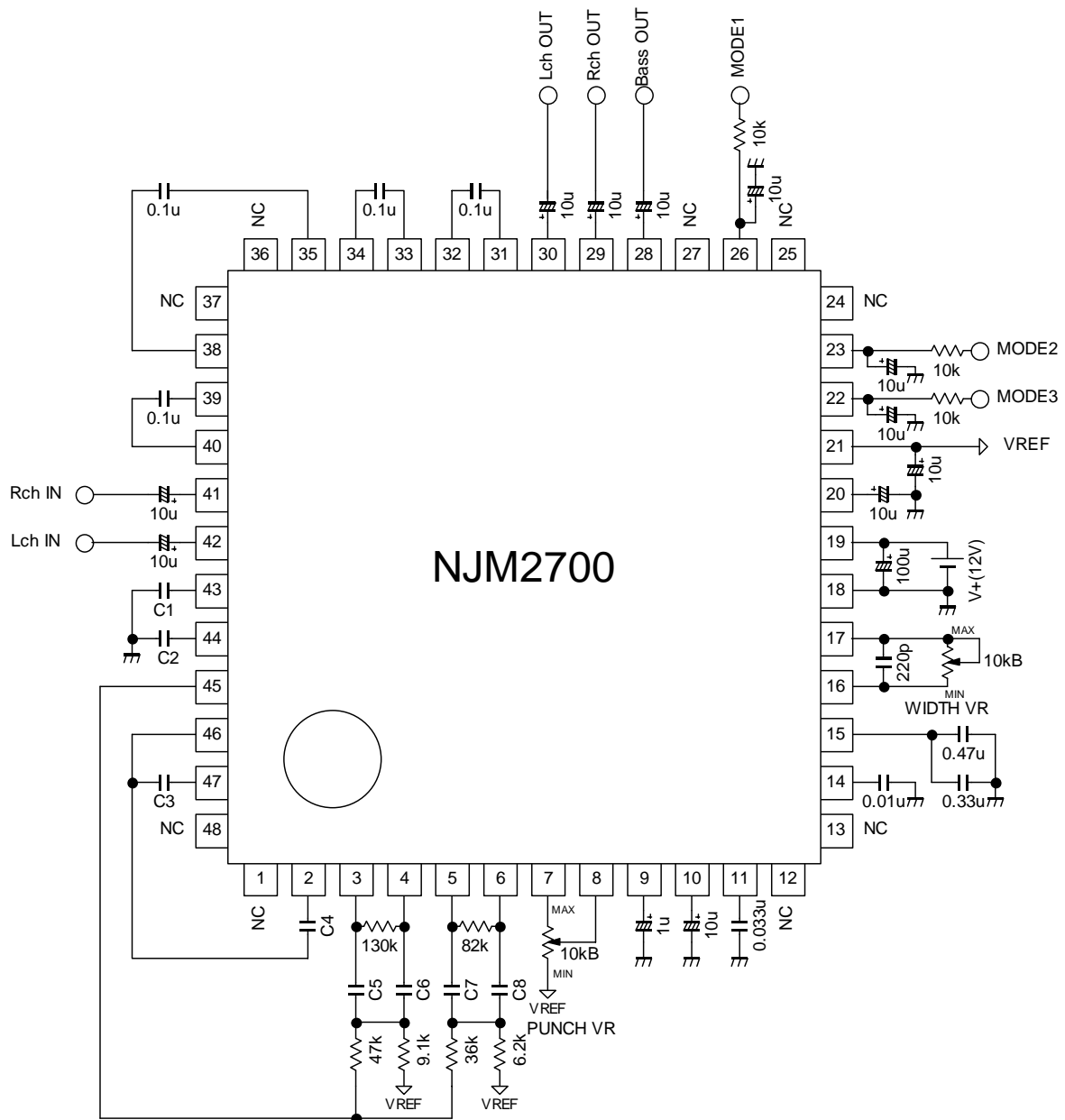

	C1	C2	C3 to C8
40Hz Setting	0.22	0.022	0.12
60Hz Setting	0.15	0.015	0.082
100Hz Setting	0.1	0.01	0.047
150Hz Setting	0.068	0.0068	0.033
200Hz Setting	0.047	0.0047	0.027
250Hz Setting	0.039	0.0039	0.022
300Hz Setting	0.033	0.0033	0.018
400Hz Setting	0.022	0.0022	0.012

Unit:  $\mu\text{F}$

### •Speaker Size Setting

Choose speaker size in accordance with  $f_0$  of the speaker.  
 (EX.) In the case of  $f_0 = 250\text{Hz}$ : 250Hz Setting.  
 Decide it after you confirm effect with the actual application.

# NJM2700

## TYPICAL CHARACTERISTICS

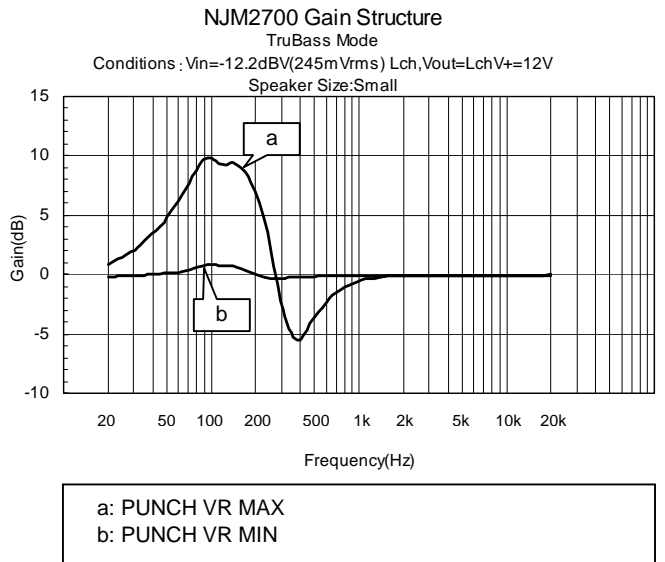
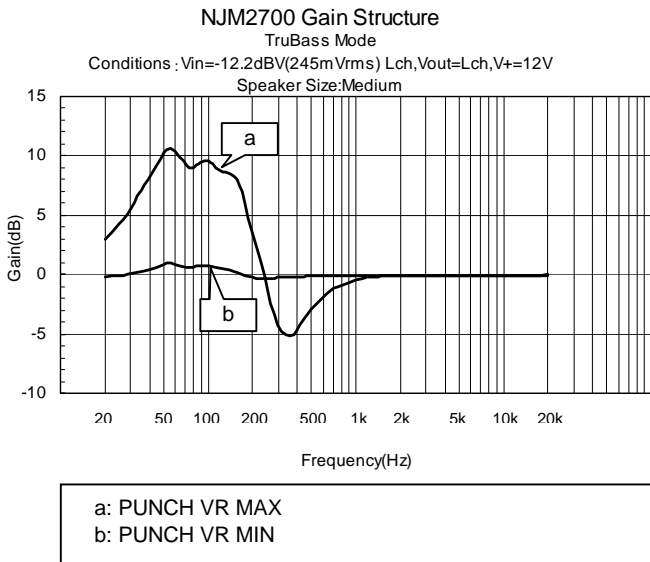
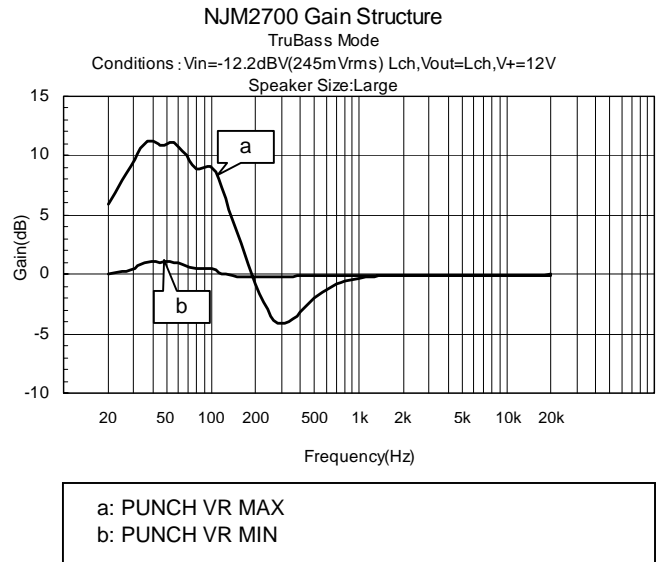
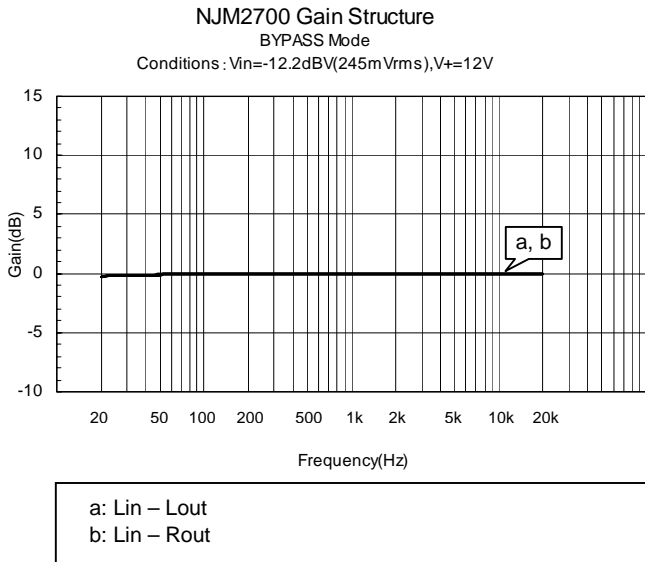

## TYPICAL CHARACTERISTICS

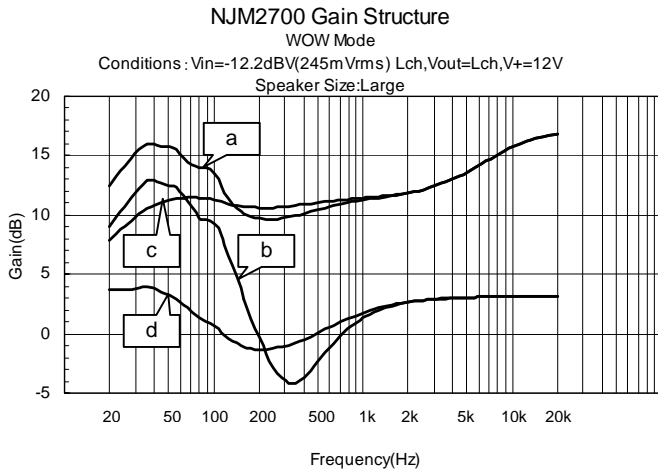

- |                  |              |
|------------------|--------------|
| a: PUNCH VR MAX, | WIDTH VR MAX |
| b: PUNCH VR MAX, | WIDTH VR MIN |
| c: PUNCH VR MIN, | WIDTH VR MAX |
| d: PUNCH VR MIN, | WIDTH VR MIN |

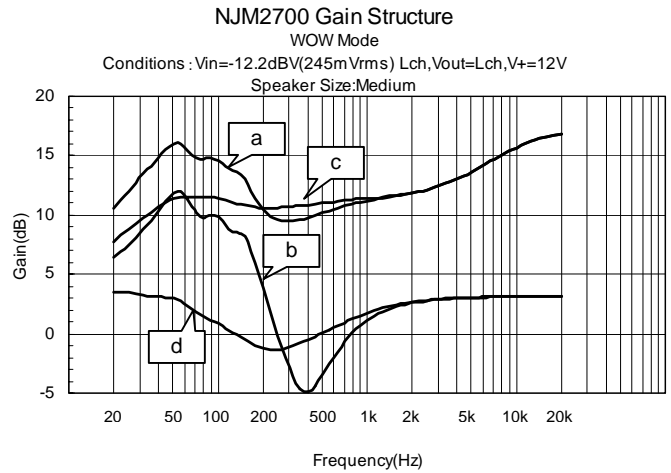

- |                  |              |
|------------------|--------------|
| a: PUNCH VR MAX, | WIDTH VR MAX |
| b: PUNCH VR MAX, | WIDTH VR MIN |
| c: PUNCH VR MIN, | WIDTH VR MAX |
| d: PUNCH VR MIN, | WIDTH VR MIN |

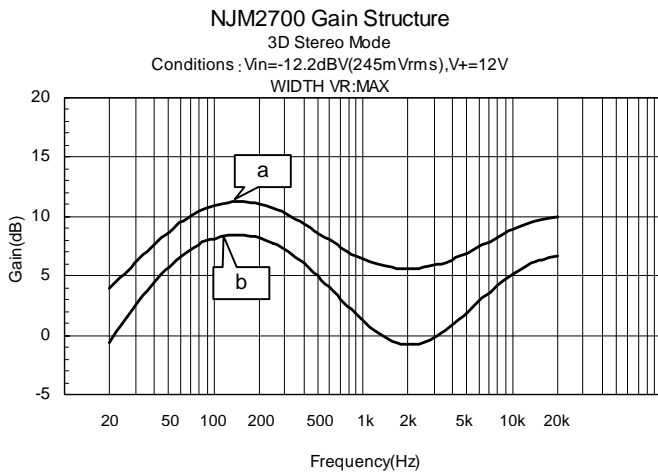

- |               |
|---------------|
| a: Lin - Lout |
| b: Lin - Rout |

**[CAUTION]**

The specifications on this databook are only given for information , without any guarantee as regards either mistakes or omissions. The application circuits in this databook are described only to show representative usages of the product and not intended for the guarantee or permission of any right including the industrial rights.