

# NEC

## 3 V, 1500 MHz Si MMIC WIDEBAND AMPLIFIER

### UPC2746T

#### FEATURES

- **WIDE FREQUENCY RESPONSE:** 1500 MHz
- **LOW VOLTAGE OPERATION:** 3 V NOMINAL (1.8 MIN)
- **LOW POWER CONSUMPTION:** 22.5 mW TYP
- **SUPER SMALL PACKAGE**
- **TAPE AND REEL PACKAGING OPTION AVAILABLE**

#### DESCRIPTION

The UPC2746T is a Silicon Monolithic integrated circuit which is manufactured using the NESAT III process. The NESAT III process produces transistors with  $f_T$  approaching 20 GHz. This device is suitable as a buffer amplifier for cellular and cordless telephone applications. Operating on a 3 volt supply (1.8 volt minimum) this IC is ideally suited for hand-held, portable designs.

NEC's stringent quality assurance and test procedures ensure the highest reliability and performance.

**NOISE FIGURE AND GAIN vs. FREQUENCY**  
Vcc = 3.0 V, Icc = 7.5 mA

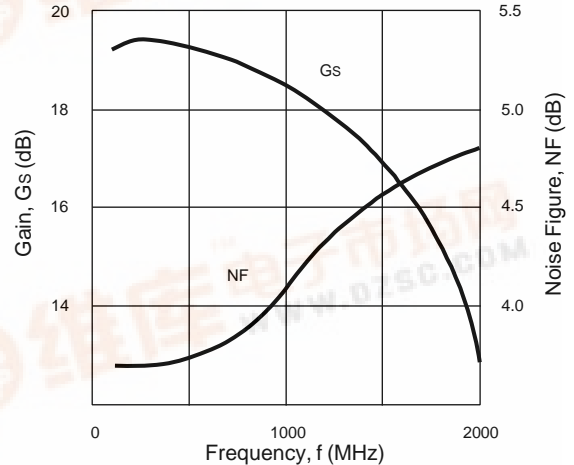

#### ELECTRICAL CHARACTERISTICS (TA = 25°C, ZL = ZS = 50Ω)

PART NUMBER PACKAGE OUTLINE			UPC2746T TO6		
SYMBOLS	PARAMETERS AND CONDITIONS	UNITS	MIN	TYP	MAX
Icc	Circuit Current (no signal) Vcc = 3.0 V Vcc = 1.8 V	mA mA	5.0	7.5 4.5	10.0
Gs	Small Signal Gain, f = 500 MHz, Vcc = 3.0 V f = 1000 MHz, Vcc = 3.0 V f = 500 MHz, Vcc = 1.8 V	dB dB dB	16	19 18.5 14	21
fu <sup>1</sup>	Upper Limit Operating Frequency, Vcc = 3.0 V Vcc = 1.8 V	GHz GHz	1.1	1.5 1.1	
PSAT	Saturated Output Power, f = 500 MHz, Vcc = 3.0 V f = 1000 MHz, Vcc = 3.0 V f = 500 MHz, Vcc = 1.8 V	dBm dBm dBm	-3	0 -1 -8	
NF	Noise Figure, f = 500 MHz, Vcc = 3.0 V f = 1000 MHz, Vcc = 3.0 V f = 500 MHz, Vcc = 1.8 V	dB dB dB		4.0 4.2 5.0	5.5
RLIN	Input Return Loss, f = 500 MHz, Vcc = 3.0 V f = 1000 MHz, Vcc = 3.0 V f = 500 MHz, Vcc = 1.8 V	dB dB dB	10	13 10 10	
RLOUT	Output Return Loss, f = 500 MHz, Vcc = 3.0 V f = 1000 MHz, Vcc = 3.0 V f = 500 MHz, Vcc = 1.8 V	dB dB dB	5.5	8.5 8.5 9.5	
ISOL	Isolation, f = 500 MHz, Vcc = 3.0 V f = 1000 MHz, Vcc = 3.0 V f = 500 MHz, Vcc = 1.8 V	dB dB dB	40	45 38 37	
OIP3	SSB Output Third Order Intercept, f1 = 500 MHz, f2 = 510 MHz, Vcc = 3.0 V f1 = 1000 MHz, f2 = 1010 MHz, Vcc = 3.0 V f1 = 500 MHz, f2 = 502 MHz, Vcc = 1.8 V	dBm dBm dBm		+5 +6 -2	
RTH (J-A)	Thermal Resistance (Junction to Ambient) Free Air Mounted on a 50 x 50 x 1.6 mm epoxy glass PWB	°C/W °C/W			620 230

Note: 1. The gain at fu is 3 dB down from the gain at 100 MHz.



# UPC2746T

## ABSOLUTE MAXIMUM RATINGS<sup>1</sup> (T<sub>A</sub> = 25°C)

SYMBOLS	PARAMETERS	UNITS	RATINGS
V <sub>CC</sub>	Supply Voltage	V	4.0
I <sub>CC</sub>	Total Supply Current	mA	16
P <sub>IN</sub>	Input Power	dBm	0
P <sub>T</sub>	Total Power Dissipation <sup>2</sup>	mW	280
T <sub>OP</sub>	Operating Temperature	°C	-40 to +85
T <sub>STG</sub>	Storage Temperature	°C	-55 to +150

**Notes:**

1. Operation in excess of any one of these parameters may result in permanent damage.
2. Mounted on a 50 x 50 x 1.6 mm epoxy glass PWB (T<sub>A</sub> = 85°C).

## RECOMMENDED OPERATING CONDITIONS

SYMBOLS	PARAMETERS	UNITS	MIN	TYP	MAX
V <sub>CC</sub>	Supply Voltage	V	1.8	3	3.3
T <sub>OP</sub>	Operating Temperature	°C	-40	25	85

## TEST CIRCUIT

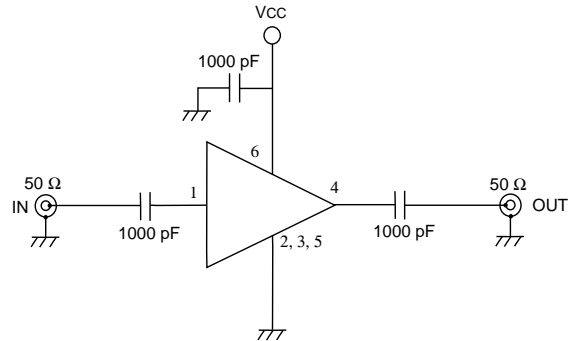

## TYPICAL PERFORMANCE CURVES (T<sub>A</sub> = 25°C)

**CIRCUIT CURRENT vs. VOLTAGE**

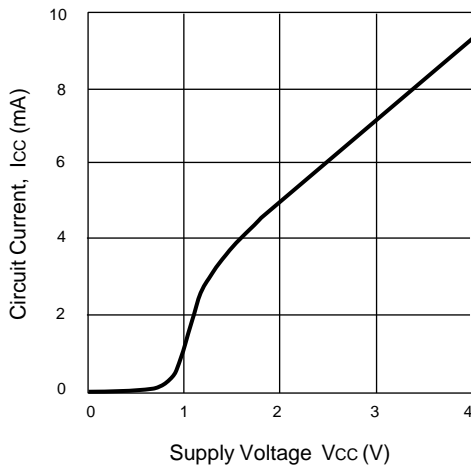

**CIRCUIT CURRENT vs. TEMPERATURE**

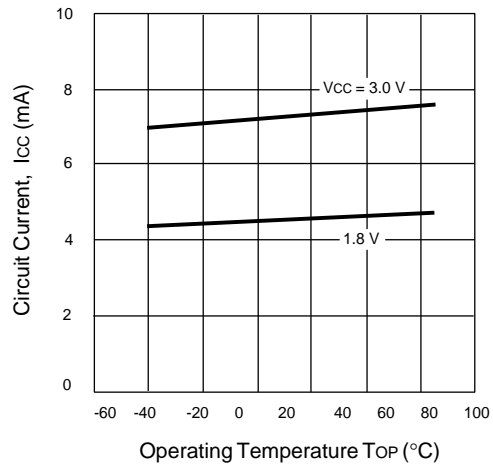

**GAIN vs. FREQUENCY AND TEMPERATURE**

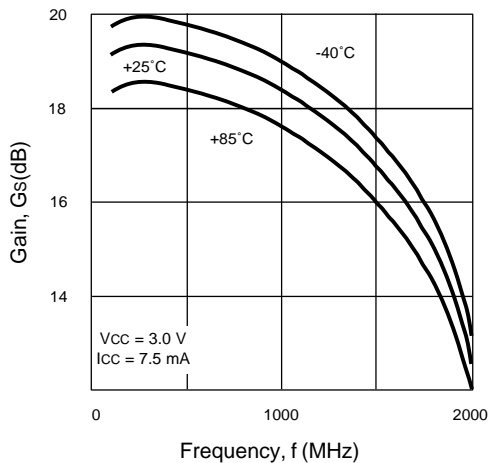

**GAIN AND NOISE FIGURE vs. FREQUENCY**

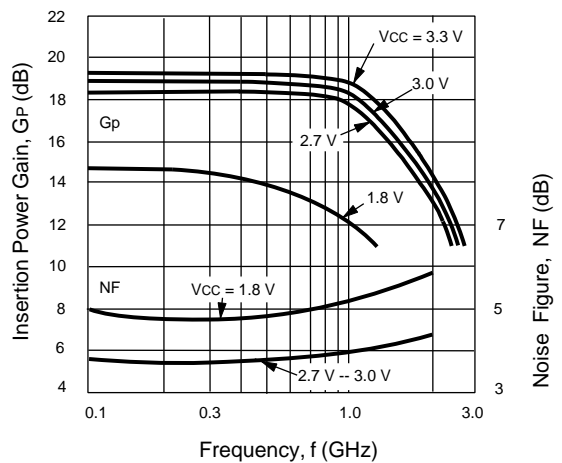

TYPICAL PERFORMANCE CURVES (TA = 25°C)

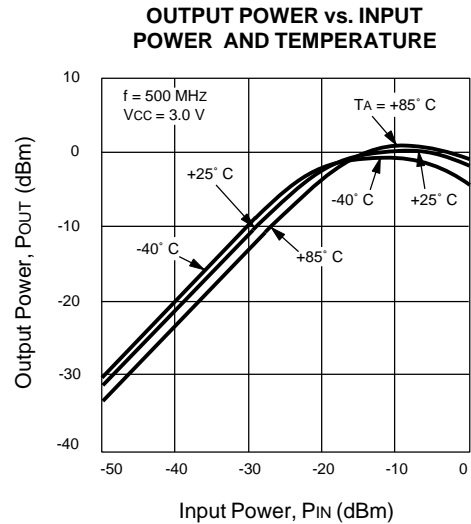
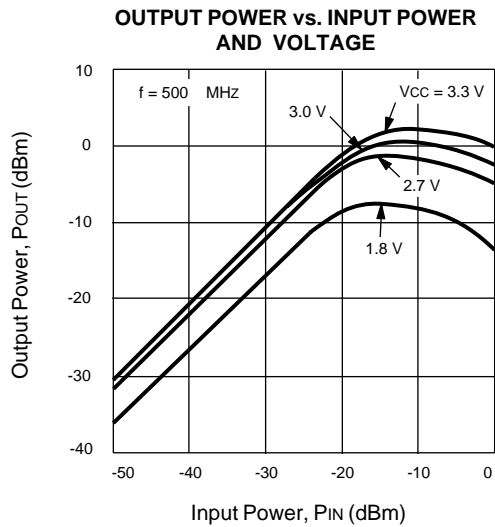
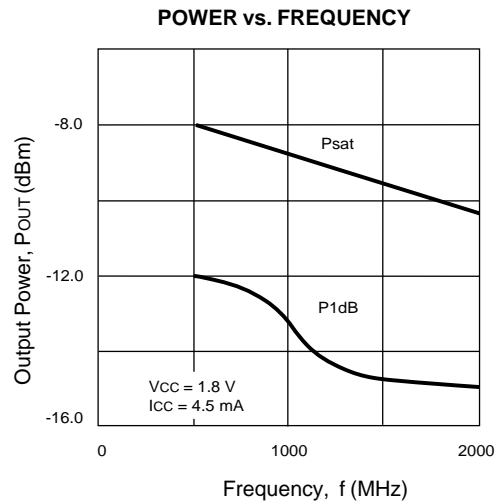
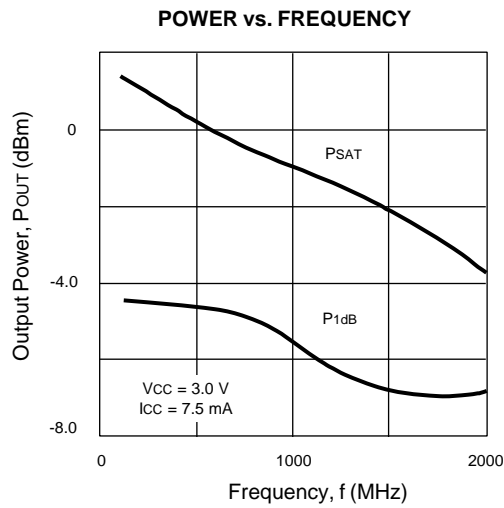
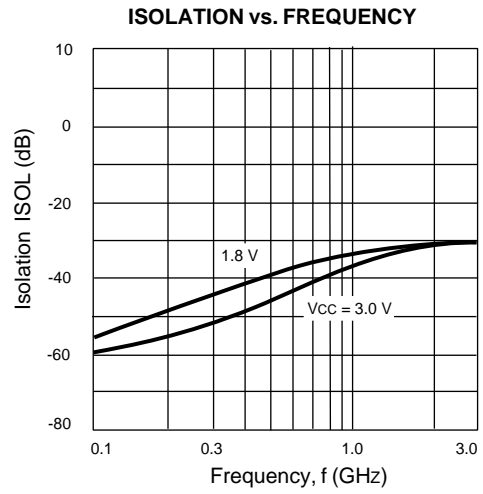
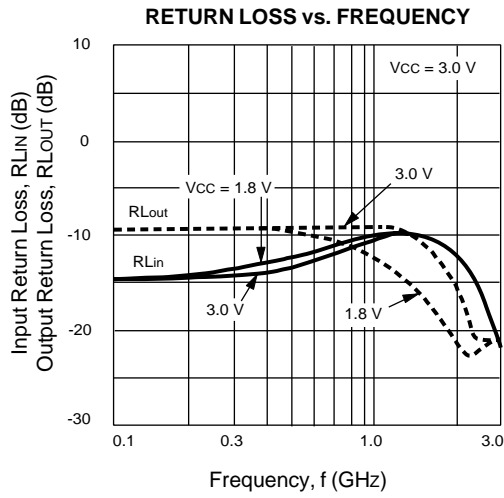

# UPC2746T

## TYPICAL SCATTERING PARAMETERS (TA = 25°C)

VCC = 3.0 V, ICC = 7.5 mA

FREQUENCY (GHz)	S11		S21		S12		S22		K <sup>1</sup>	S21 (dB)
	MAG	ANG	MAG	ANG	MAG	ANG	MAG	ANG		
0.1	0.213	164.0	9.11	-6.4	0.001	122.7	0.362	-2.5	45.48	19.2
0.2	0.204	146.5	9.30	-15.3	0.002	118.8	0.359	-6.0	22.39	19.4
0.3	0.197	130.0	9.30	-25.0	0.003	114.7	0.365	-9.2	14.88	19.4
0.4	0.201	117.8	9.23	-34.3	0.004	110.5	0.370	-12.0	11.17	19.3
0.5	0.209	106.1	9.17	-43.6	0.005	106.6	0.378	-15.6	8.89	19.2
0.6	0.219	93.9	9.08	-53.0	0.006	102.4	0.382	-19.7	7.41	19.2
0.7	0.231	87.3	8.91	-62.0	0.008	98.8	0.389	-23.9	5.59	19.0
0.8	0.242	76.6	8.75	-71.9	0.009	94.6	0.389	-29.0	5.03	18.8
0.9	0.255	66.3	8.61	-81.5	0.011	90.8	0.393	-34.8	4.13	18.7
1.0	0.265	56.2	8.46	-91.9	0.012	87.2	0.385	-40.5	3.86	18.5
1.1	0.275	45.6	8.15	-101.4	0.013	83.0	0.381	-47.5	3.68	18.2
1.2	0.286	35.5	7.79	-110.5	0.014	79.7	0.368	-52.4	3.59	17.8
1.3	0.296	26.5	7.44	-119.6	0.015	76.0	0.355	-58.9	3.53	17.4
1.4	0.300	18.6	6.98	-129.1	0.016	74.2	0.335	-64.3	3.57	16.9
1.5	0.296	11.5	6.55	-137.8	0.016	72.6	0.314	-70.1	3.88	16.3
1.6	0.292	4.7	6.08	-146.4	0.016	71.0	0.290	-75.1	4.27	15.7
1.7	0.288	-0.5	5.63	-153.8	0.016	68.9	0.264	-78.7	4.71	15.0
1.8	0.285	-4.4	5.21	-161.5	0.017	67.4	0.235	-81.4	4.88	14.3
1.9	0.281	-10.1	4.77	-168.8	0.017	65.8	0.206	-83.1	5.42	13.6
2.0	0.266	-16.2	4.25	-175.0	0.017	61.3	0.180	-84.8	6.21	12.6

VCC = 1.8 V, ICC = 4.5 mA

FREQUENCY GHz	S11		S21		S12		S22		K <sup>1</sup>	S21 (dB)
	MAG	ANG	MAG	ANG	MAG	ANG	MAG	ANG		
0.1	0.211	11.1	5.15	-8.7	0.003	38.3	0.355	-5.3	26.96	14.2
0.2	0.255	8.5	5.11	-19.8	0.004	43.9	0.355	-10.6	19.92	14.2
0.3	0.287	6.5	5.00	-31.2	0.006	49.3	0.353	-16.2	13.31	14.0
0.4	0.302	3.5	4.88	-41.2	0.008	54.9	0.346	-21.1	10.18	13.8
0.5	0.316	-1.5	4.73	-51.3	0.009	59.1	0.339	-26.1	9.29	13.5
0.6	0.329	-5.5	4.58	-61.1	0.011	61.0	0.329	-30.4	7.83	13.2
0.7	0.341	-9.9	4.41	-69.9	0.013	60.8	0.321	-35.8	6.85	12.9
0.8	0.352	-14.8	4.17	-79.8	0.014	59.3	0.305	-40.4	6.75	12.4
0.9	0.361	-19.2	3.94	-89.1	0.015	57.0	0.298	-46.1	6.64	11.9
1.0	0.367	-25.0	3.75	-100.0	0.016	54.6	0.277	-51.3	6.60	11.5
1.1	0.372	-29.5	3.57	-108.4	0.018	49.4	0.264	-56.2	6.18	11.1
1.2	0.378	-34.3	3.47	-114.7	0.019	45.7	0.247	-59.1	6.05	0.8
1.3	0.381	-38.7	3.26	-122.8	0.020	43.8	0.237	-63.7	6.13	10.3
1.4	0.375	-42.1	3.13	-131.0	0.020	42.9	0.219	-65.0	6.49	9.9
1.5	0.371	-47.2	2.95	-138.5	0.021	41.9	0.206	-69.6	6.62	9.4
1.6	0.363	-51.2	2.78	-145.6	0.021	41.0	0.187	-70.4	7.14	8.9
1.7	0.355	-56.1	2.60	-153.1	0.020	40.5	0.166	-71.8	8.14	8.3
1.8	0.337	-58.5	2.51	-158.7	0.020	40.1	0.155	-71.4	8.59	8.0
1.9	0.325	-61.2	2.40	-166.5	0.020	39.8	0.136	-69.7	9.12	7.6
2.0	0.312	-63.9	2.28	-171.6	0.019	39.6	0.120	-69.6	10.25	7.2

Note:

1. K Factor Calculation:

$$K = \frac{1 + |\Delta|^2 - |S_{11}|^2 - |S_{22}|^2}{2 |S_{12} S_{21}|}, \Delta = S_{11} S_{22} - S_{21} S_{12}$$

# UPC2746T

## OUTLINE DIMENSIONS (Units in mm)

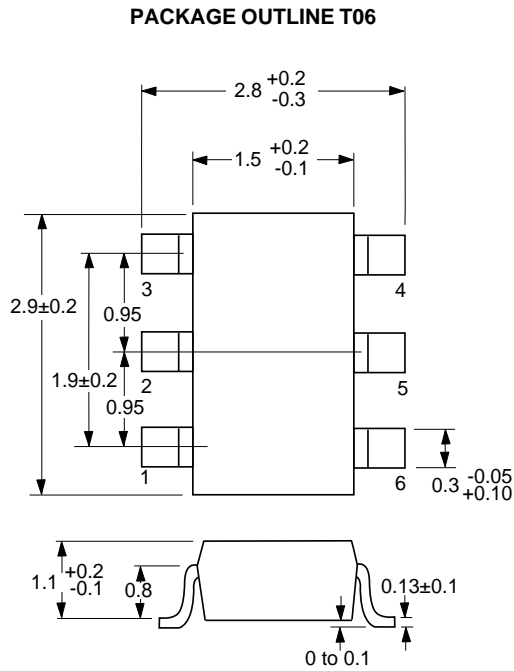

Note:  
 All dimensions are typical unless otherwise specified.

## LEAD CONNECTIONS

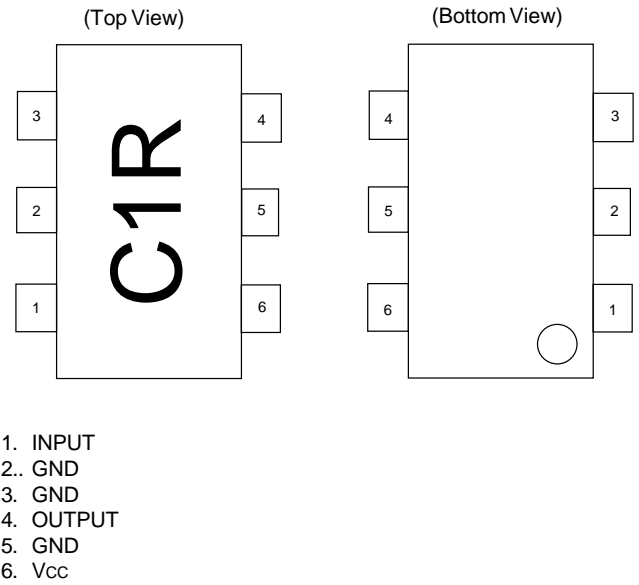

## EQUIVALENT CIRCUIT

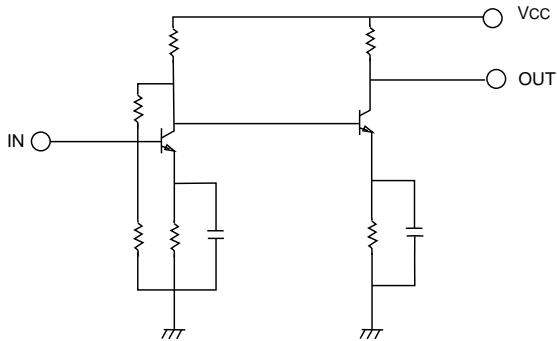

## RECOMMENDED P.C.B. LAYOUT (Units in mm)

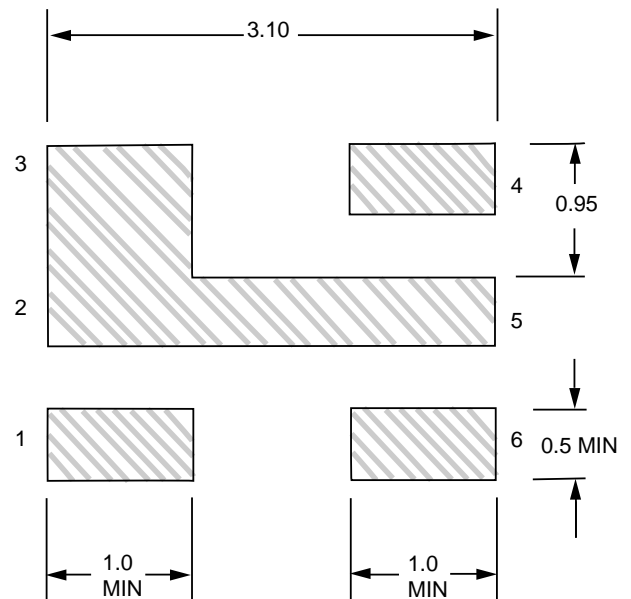

## ORDERING INFORMATION

PART NUMBER	QTY
UPC2746T-E3	3K/Reel

Note:  
 Embossed Tape, 8 mm wide.