



Optical Electronics
Incorporated

AH 2910

DATA AND SPECIFICATIONS
DESCRIPTION AND INSTRUCTIONS

10 MHz BIPOLAR LOGARITHMIC AMPLIFIER

FEATURES

- WIDE BANDWIDTH: 10 MHz
- WIDE DYNAMIC RANGE: 80 dB
- LOG • ANTILOG
- CURRENT AND VOLTAGE INPUTS

APPLICATIONS

- AUDIO COMPRESSION
- LOG • ANTILOG
- ULTRA SONIC MEASUREMENTS
- SONAR
- VIDEO LOG

DESCRIPTION

The 2910 bipolar logarithmic amplifier is designed to perform logarithmic or antilogarithmic functions on the signals applied to its inputs. Square root functions can also be implemented. Its specifications make it most suitable to a variety of applications. The hybrid design, packaged in a 16 pin Dual-In-Line Package, allows use of standard sockets and takes up only a minimum of PC board real estate.

The 2910 has been designed to fill the gap that exists for logarithmic and antilogarithmic amplifiers, where wide available bandwidth and wide dynamic range at high frequencies is concerned. Most amplifiers of this kind have wide bandwidth and good dynamic range at frequencies near DC. The dynamic range of the device covers a minimum of 4 decades (80 db). Over 75% of this range (60 db) a logarithmic error of only $\pm 0.7\%$ is typical, with a maximum error of only $\pm 3\%$ at the upper portion of the dynamic range. The frequency response registers a full 1 to 10 MHz and the 2910 can therefore be used for a variety of video applications.

Another advantage of the design of the 2910 is the fact that, although the device is current driven, appropriate scaling resistors, applied externally or by use of the built-in resistors, allow it to become a voltage driven amplifier.

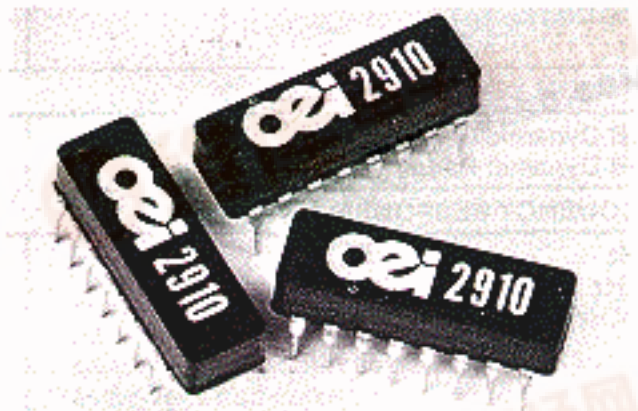

The low power consumption, even at the maximum rated output, make the device energy efficient. The $\pm 100\text{mV}$ to $\pm 400\text{mV}$ output range can be scaled to any requirements with the addition of a simple operational amplifier.

The 2910 can easily be compensated with the application of a single capacitor. Because of the influence of this capacitor on the dynamic range and frequency response, performance can easily be shaped to fit even filtering applications. As would be expected, an increase in capacitance decreases the bandwidth of the device.

The 2910 finds applications in video and audio compression circuits and any other place where a logarithmic or antilogarithmic function is required. Even square root signal processing can easily be accomplished. The wide frequency range also

SPECIFICATIONS

ELECTRICAL

Specifications at $T_A = +25^\circ\text{C}$, $V_{CC} = \pm 15\text{VDC}$ unless otherwise noted.

MODEL		2910		
PARAMETER	MIN	TYP	MAX	UNITS
DYNAMIC RANGE				
	80			dB
RATED OUTPUT				
Voltage	± 100		± 400	mV
Current	± 1			mA
Dynamic Resistance			3	Ω
Output Coefficient		75		mV/decade
Temperature Coefficient		-1.6		$\text{mV}/^\circ\text{C}$
INPUT				
Dynamic Range	$\pm 3 \times 10^{-7}$		$\pm 3 \times 10^{-3}$	A
Dynamic Range	± 0.0001		± 10	V
Resistance Current Input			1	Ω
Resistance Voltage Input	1K		10K	Ω
Polarity		Bipolar		
INPUT OFFSET VOLTAGE				
Initial Offset		ADJ		
Drift			± 100	$\mu\text{V}/^\circ\text{C}$
INPUT BIAS CURRENT				
Initial Bias			± 20	μA
Drift			± 500	$\text{nA}/^\circ\text{C}$
MAXIMUM LOGARITHMIC ERROR				
80dB Dynamic Range		1	3	%
60dB Dynamic Range		0.7		%
FREQUENCY RESPONSE				
1KHz		80		dB
10KHz		80		dB
100KHz		80		dB
1MHz		60		dB
3MHz		40		dB
10MHz		20		dB
TEMPERATURE RANGE				
Thermal Resistance of Package			60	$^\circ\text{C}/\text{W}$
Quiescent Temp Rise			22	$^\circ\text{C}$
Operating	-25		+85	$^\circ\text{C}$
Storage	-55		+125	$^\circ\text{C}$
POWER SUPPLY				
Rated Voltage	± 5	± 15	± 20	V
Current Quiescent			± 12	mA

MECHANICAL DESCRIPTION: The 2910 is a standard 16-pin DIP. Its pins are compatible with standard 0.3-inch dual in-line sockets. The case is made of glass-fiber-filled diallylphthalate and is filled with epoxy encapsulant.

PIN CONNECTIONS	
1 Output	10 Input Offset
3 -V Supply	12 10k Voltage Input
4 Log Element	13 Current Input

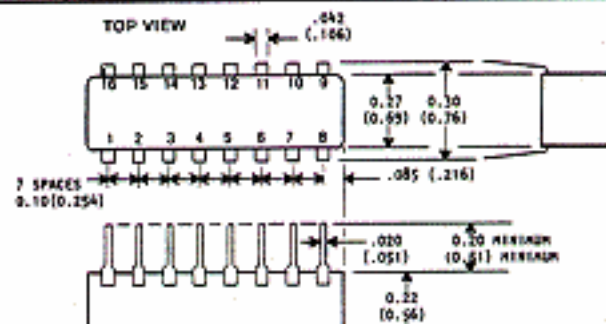

2910 TYPICAL PERFORMANCE CURVES

($T_A = +25^\circ\text{C}$, $V_{CC} = \pm 15\text{VDC}$ unless otherwise noted)

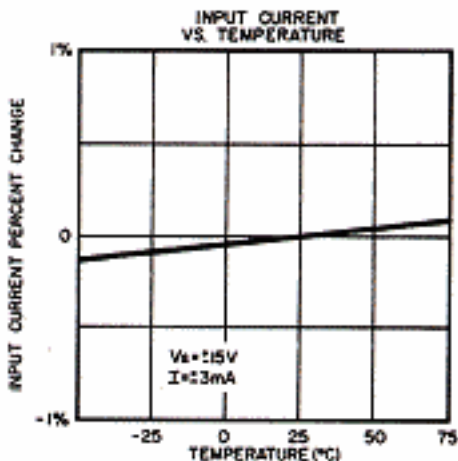
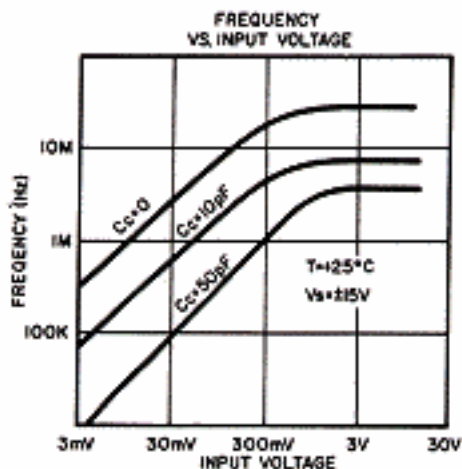
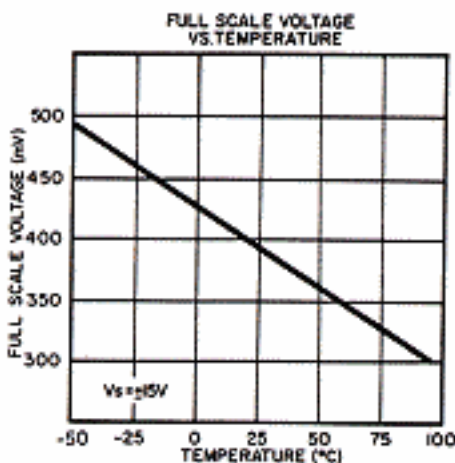
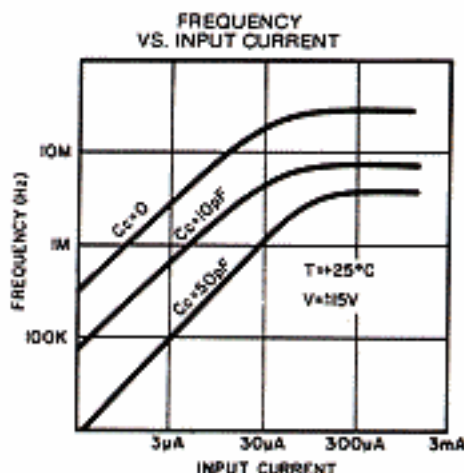
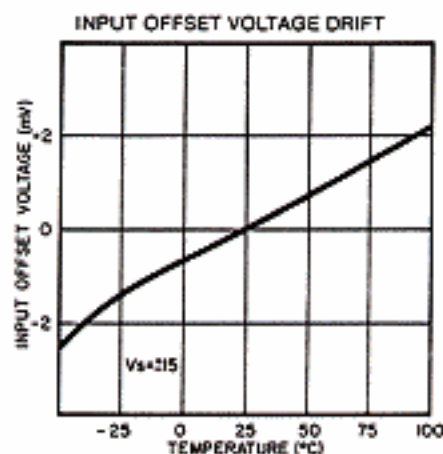
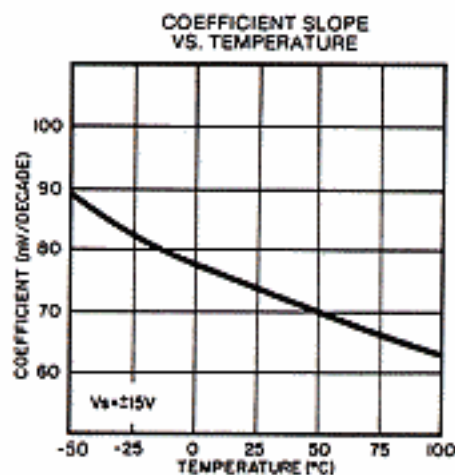

There are some misconceptions regarding the operation and function of logarithmic amplifiers. To explain this a bit better, the following figure is provided.

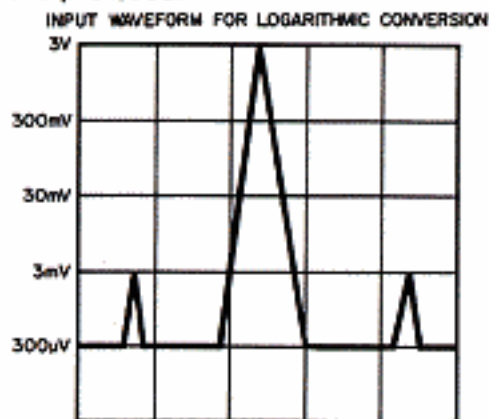

The vertical axis shows an input signal voltage of a given frequency. The horizontal axis indicates a time axis. No particular scale is shown because this axis is only representative. The voltage is a positive going signal that uses a $+300\mu\text{V}$ offset with alternative spikes ranging to 3mV and 3V . It must be remembered that the logarithm of 0 is not defined and if a signal is

If one assumes that a 30dB dynamic range is used, the 3V input signal will be presented by a 400mV output.

The 3mV signal is then 3 decades down from the 3V which translates to a 225mV difference so that the output appears as $400\text{mV} - 225\text{mV} = 175\text{mV}$.

The advantage of the OEI devices is their ability to do logarithmic conversions at frequencies to 10MHz . Devices with outstanding DC characteristics abound on the market, but none is capable of operations at higher frequencies.

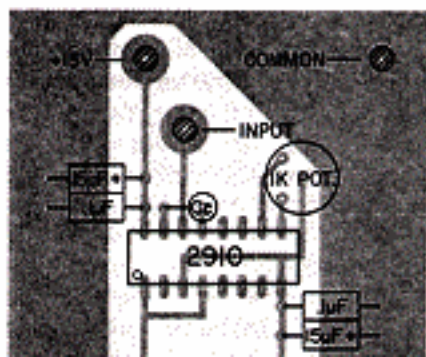

TYPICAL
BOARD
LAYOUT

INTRODUCTION

The 2910 bipolar logarithmic amplifier can be employed whenever logarithmic or antilogarithmic functions are required. Since the device is current driven, the input voltage to the device must be converted to a current by use of internal or external resistors. Input current levels range from 300 nanoamps to 3 milliamps and this 80dB range provides output voltages between 100 and 400 millivolts with an output coefficient of 75 mV/decade. The output follows the ideal logarithmic function with a high accuracy up to 10 MHz for small signals.

THEORY OF OPERATION

The 2910 is basically an operational amplifier with a log element in its feedback loop, or at the device input. Thus advantage is taken of the exponential relationship between current and voltage exhibited by a pn junction. Depending on the connection scheme used, logarithmic or antilogarithmic functions can be obtained with the same device.

The relationship of current through the log element and the voltage across it can be expressed by,

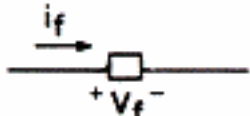
$$i_f = I_0 (e^{V_f/K} - 1) \quad (1)$$

where i_f current through logging element

I_0 reverse current

V_f voltage across logging element

and where the factor K is dependent on junction material and temperature. If the log element is connected in the feedback-loop of an operational amplifier, the input current becomes i_f and the output voltage becomes V_f , as shown in the diagram below, if it is between 3×10^{-3} and 3×10^{-7} Amp.

Since the input current i_f is equal to V_{in}/R the equation for the logging element becomes

$$\frac{V_{in}}{R} = i_f = I_0 (e^{V_o/K} - 1) \quad (2)$$

For large enough output voltages the exponential expression becomes very much larger than 1 and the equation can be simplified. If the natural logarithm is taken on both sides and the equation is rearranged it reads:

$$V_o = -K \ln \frac{V_{in}}{R} + K \ln I_0 \quad (3)$$

This shows that the output voltage is proportional to the logarithm of the input voltage, plus a constant. The constant K as well as the inverse

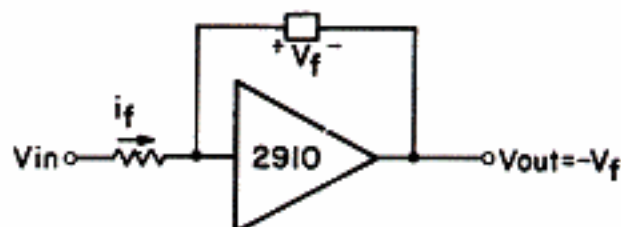

Instead of inserting the logging element in the feedback-loop it can be connected to the input of the operational amplifier. The feedback resistor R_f is then used. With this arrangement, shown below, the appropriate equations become:

$$i_f = I_0 e^{V_f/K} - I_0 \quad (4)$$

$$I_1 = \frac{V_o}{R_f} \quad (5)$$



$$\text{for } 3 \times 10^{-7} \text{ Amp} \leq \frac{V_o}{R_f} \leq 3 \times 10^{-3} \text{ Amp}$$

Since the current i_f equals $-I_0$ and the input voltage V_{in} equals V_f the equation becomes:

$$V_o = -R_f I_0 (e^{V_{in}/K} - 1) \quad (6)$$

For the case of $e^{V_{in}/K} \ll 1$ the equation becomes:

$$V_o = -R_f I_0 e^{V_{in}/K} \quad (7)$$

Which shows that the output voltage is the antilogarithm of the input voltage.

APPLICATIONS

The transfer function and accuracy limitations of the 2910 are given below:

$$V_o = -K \ln \frac{V_{in}}{R_{in}} + K \ln I_0 \quad 3 \times 10^{-4} \text{ mA} \leq \frac{V_{in}}{R_{in}} \leq 3 \text{ mA}$$

$$100 \text{ mV} \leq V_o \leq 400 \text{ mV}$$

$$K = .0326 \text{ at } 25^\circ \text{C}$$

$$I_0 = 1.4 \times 10^{-8} \text{ Amp}$$

As is shown, the logarithmic relationship holds for V_o between 300 nanoAmps to 3 milliamps. The constant $K \ln I_0$ is approximately .6 Volts at 25°C and may be subtracted by the offset adjustment.

Due to the temperature sensitivity of the pn

in degrees Kelvin. As a result, for a given input current, the output voltage will vary as a function of temperature. This behavior must also be taken into account, and appropriate means of compensation must be designed into the circuit. In the section with typical performance curves, data can be found for this purpose. For a $\pm 25^{\circ}\text{C}$ temperature swing, the output voltage can vary as much as $\pm 35\text{mV}$.

When multiplying logarithmically the constant K will be additive and thus must be taken into account when designing with the 2910. Division of two numbers cancels the constant automatically. Conversion to logarithms of other bases can be accomplished by appropriate gain adjustments of the following stages. Depending on the connections chosen the 2910 will either produce an output that is proportional to the logarithm of the input, or an output that is proportional to the antilogarithm of the input as shown below:

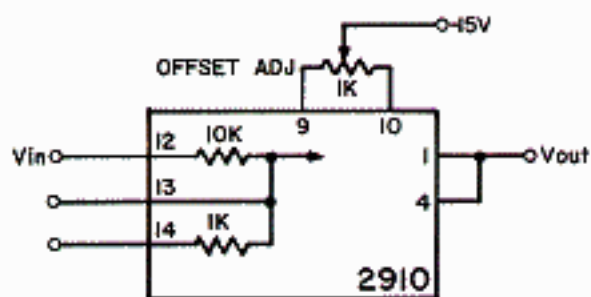

Logarithmic output

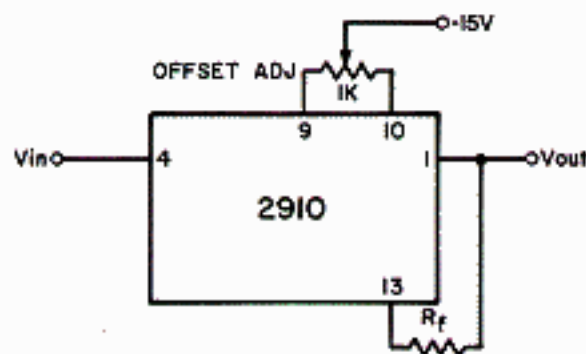

Antilogarithmic output

For a logarithmic output pins 1 and 4 are tied together, and provide the output voltage V_o . A 1K ohm potentiometer (trimpot) is connected between pins 9 and 10. This offset adjustment pot must be included in any design with the 2910. The input can be applied to either pins 12, 13, or 14. If an external resistor is used, or the input is a current, connection can be made to pin 13. However, for convenience, the 2910 also contains a 1K ohm and a 10K ohm resistor. Either one can be used for a voltage input.

These resistors can also be used as feedback resistors in the antilog mode. Here pin 1 provides the output voltage. Feedback is accomplished via an external resistor to pin 13 or by use of either of the internal resistors on pin 12 or 14 respectively. The offset adjustment pot of 1K ohm is also mandatory for this use, and it is connected between pins 9 and 10.

The offset voltage, caused by some mismatch in the logarithmic elements, is small and can be adjusted by applying a bipolar signal to the input. The offset can then be adjusted, until the output swings to equal magnitude in both the positive and negative direction.

BASIC CONNECTIONS, TYPICAL APPLICATIONS.

The diagram in figure 1 shows the 2910 in the basic log connection. Pins 12, 13, or 14 provide the input terminals and can be used for current or

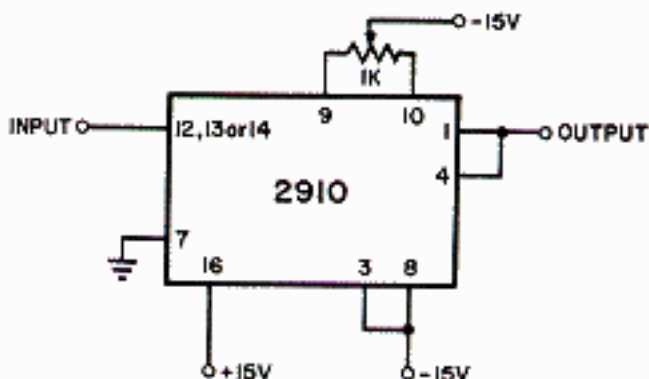
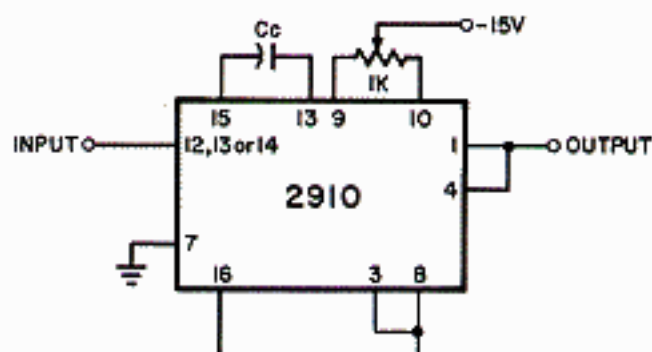

FIGURE 1: BASIC CONNECTIONS

voltage sources. The input voltage range for pin 12 is ± 3 millivolts to 30 volts for a ± 15 volt power supply. Voltage sources between ± 0.3 millivolts to ± 3 volts can make use of the 10 times smaller internal resistor of 1K ohm available at pin 14. Pins 1 and 4 must be tied together to make the output connection. As mentioned before, the offset adjustment potentiometer, connected between pins 9, 10 and the negative power supply is mandatory. If this adjustment is not available the dynamic range of the circuit will suffer.

The diagram of figure 2 is, as the previous one,



designed as a logarithmic amplifier. As shown there, input signals are applied to pins 12, 13 or 14 with the same voltage ranges. This diagram differs from the one in figure 1 in that a compensation capacitor C_C is connected between pins 13 and 15. Polarity must be observed. This capacitor will overcompensate the 2910 and thus reduce the bandwidth the device is capable of providing. In most applications, this measure is not necessary and actually detrimental to the overall performance. However, when the circuit is particularly noisy, C_C will better the noise performance of the 2910.

The basic antilogarithm connections are given in the diagram of figure 3. As shown, the input and output pins are essentially reversed. The input

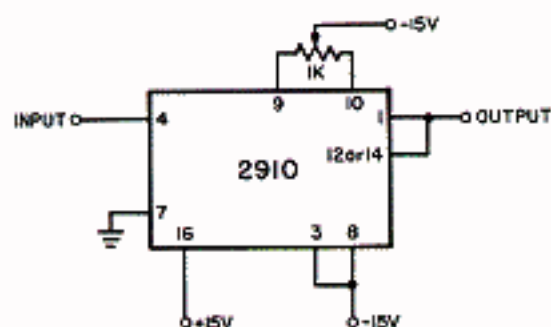

FIGURE 3: BASIC ANTI-LOGARITHMIC CONNECTION

signal is applied at pin 4 and input voltages can range from ± 100 millivolts to ± 400 millivolts. Pin 1 together with pin 12 or pin 14 provide the output. When high accuracy is required, pin 12 should be used, and for widest bandwidth, pin 14 will serve best. Here as in the other circuits, use of the 1K ohm trimpot is mandatory, particularly at lower signal levels. Figure 4 shows a 2910 application when a current source is available as input. Currents can

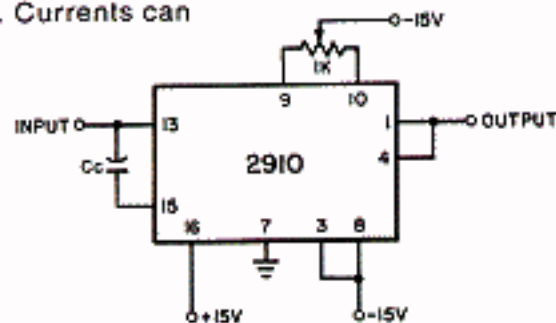

FIGURE 4: CURRENT INPUT CONNECTIONS

range from $\pm .3 \mu\text{Amps}$ to ± 3 milliamps for a full range of output voltages. If the current source is used, the bypass capacitor C_C may be necessary with values from 10pF to .001 μF . As with all 2910 applications, a compensation potentiometer between the pins 9, 10, and negative supply is required.

Figure 5 is essentially a repetition of the diagram of figure 4 except that the input is series connected to the signal source via a resistor. This then allows the source to be a voltage source. R must be selected to keep input currents inside the specified limits.

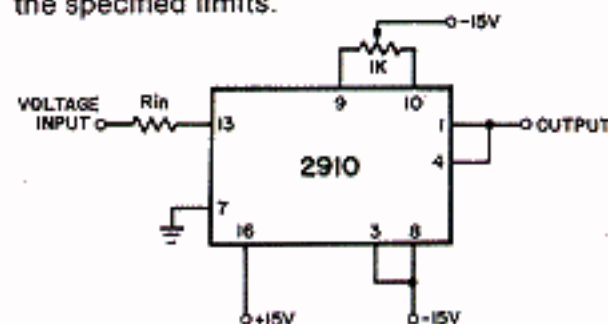

FIGURE 5: VOLTAGE INPUT CONNECTIONS

Throughout these discussions, mention has been made of the importance of the offset compensation of circuits employing the 2910. Figure 6 shows a circuit designed for cases where very accurate offset adjustments must be made. The

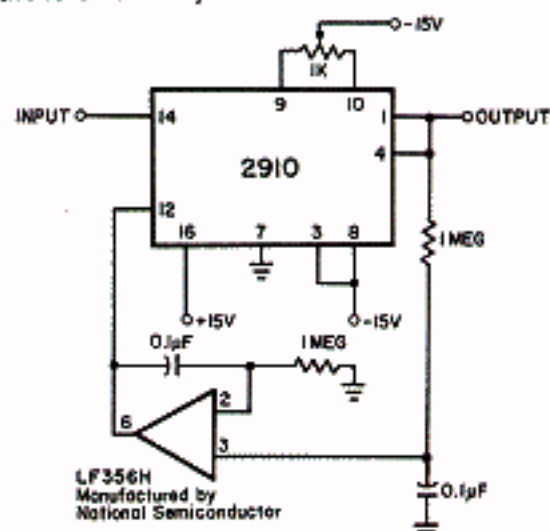

FIGURE 6: STABILIZED BIPOLAR OR LOW DUTY CYCLE PULSE LOGARITHMIC AMPLIFIER

circuit is a rivet circuit that allows coarse adjustment via the offset pot, which is connected between pins 9, 10 and the negative supply voltage. The input is again connected at pin 14. The output taken off pins 1 and 4, is fed back via a 1 Megohm resistor to the input of the LF 356H operational amplifier. The .1 μF capacitor shorts any possible AC voltage to ground, thus letting this input follow the average DC offset of the input. The other operational amplifier input is held at virtual ground via the 1 Megohm resistor. The output of this amplifier is connected to pin 12 of the 2910 and thus provides soft offset corrections automatically. This circuit is recommended when the dynamic range capability of the 2910 should be fully taken advantage of, for example, when processing bipolar or low duty cycle pulse signals.