

XC6212 Series

High Speed LDO Regulators, Low ESR Cap. Compatible, Output ON/OFF Control

October 27, 2003 V3

- Low Power Consumption : 25 μ A (TYP.)
- Dropout Voltage : 60mV @ 30mA
: 200mV @ 100mA
- Maximum Output Current : up to 150mA
- Highly Accurate : $\pm 2\%$ (± 30 mV less than 1.5V)
- Output Voltage Range : 0.9V ~ 6.0V (50mV Step)
- Low ESR capacitor compatible

■ GENERAL DESCRIPTION

The XC6212 series are highly precise, low noise, positive voltage LDO regulators manufactured using CMOS processes. The series achieves high ripple rejection and low dropout and consists of a voltage reference, an error amplifier, a current limiter and a phase compensation circuit plus a driver transistor.

Output voltage is selectable in 50mV increments within a range of 0.9V ~ 6.0V.

The series is also compatible with low ESR ceramic capacitors which give added output stability. This stability can be maintained even during load fluctuations due to the excellent transient response of the series.

The current limiter's foldback circuit also operates as a short protect for the output current limiter and the output pin.

The CE function enables the output to be turned off, resulting in greatly reduced power consumption.

■ APPLICATIONS

- Mobile phones, Cordless phones
- Wireless communication equipment
- Portable games
- Cameras, Video recorders
- Portable AV equipment
- Reference voltage
- Battery powered equipment

■ FEATURES

- Maximum Output Current : 150mA
- Dropout Voltage : 200mV (IOUT=100mA)
- Maximum Operating Voltage : 2.0V ~ 10V
- Output Voltage Range : 0.9V~6.0V (50mV Step)
- Highly Accurate : $\pm 2\%$ (VOUT>1.5V)
: ± 30 mV (VOUT \leq 1.5V)
- Low Power Consumption : 25mA (TYP.)
- Standby Current : Less than 0.1mA (TYP.)
- High Ripple Rejection : 70dB (10kHz)
- Operating Temperature Range : -40°C ~ +85°C
- Low ESR Capacitor Compatible : Ceramic capacitor
- Ultra Small Packages : SOT-25 (SOT-23-5)

■ TYPICAL APPLICATION CIRCUIT

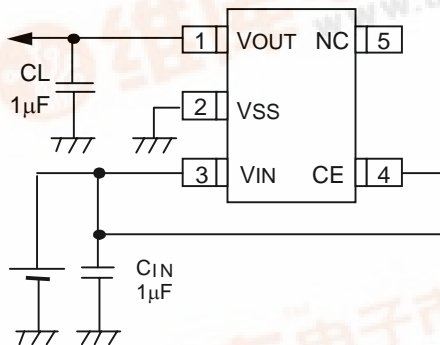

■ TYPICAL PERFORMANCE CHARACTERISTICS

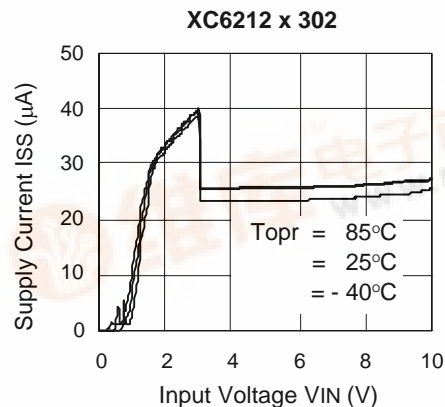

XC6212 Series

High Speed LDO Regulators, Low ESR Cap. Compatible, Output ON/OFF Control

PIN CONFIGURATION

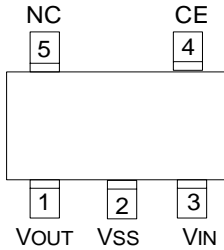

SOT-25 (SOT-23-5)
(TOP VIEW)

PIN ASSIGNMENT

PIN NUMBER	PIN NAME	FUNCTION
1	VOUT	Output
2	VSS	Ground
3	VIN	Power Input
4	CE	ON / OFF Control
5	NC	No Connection

BLOCK DIAGRAM

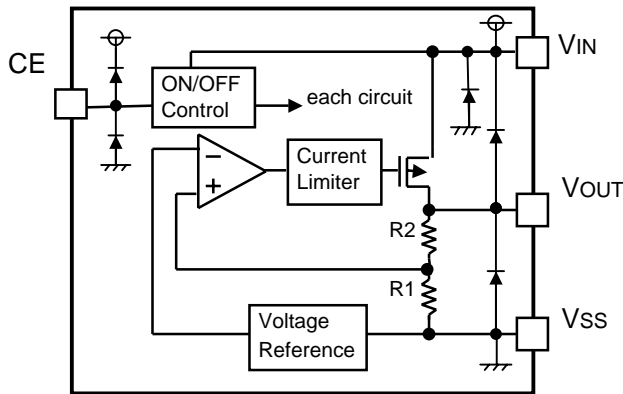

SELECTION GUIDE

The following options for the CE pin logic and internal pull-up/down are available:

- Active 'High' + no pull-down resistor built-in (standard)
- Active 'High' + 2.0M Ω pull-down resistor built-in <between CE-VSS> (semi-custom)
- Active 'Low' + no pull-up resistor built-in (semi-custom)
- Active 'Low' + 2.0M Ω pull-up resistor built-in <between VIN-CE> (semi-custom)

Note: *With the pull-up resistor or pull-down resistor built-in types, the supply current during operation will increase by $V_{IN} / 2.0M\Omega$ (TYP.).

ORDERING INFORMATION

XC6212①②③④⑤⑥

DESIGNATOR	SYMBOL	DESCRIPTION	DESIGNATOR	SYMBOL	DESCRIPTION
①	A	Active 'High', Pull-down resistor built in (Semi-custom)	④	2	Output Voltage : 100mV Step Accuracy : within $\pm 2\%$ e.g. ②=2, ③=8, ④=2 \Rightarrow 2.80V
	B	Active 'High', No pull-down resistor built in (Standard)		A	Output Voltage : 50mV Step Accuracy : within $\pm 2\%$ e.g. ②=2, ③=8, ④=A \Rightarrow 2.85V
	C	Active 'Low', Pull-up resistor built in (Semi-custom)	⑤	M	Package Type : SOT-25 (SOT-23-5)
	D	Active 'Low', No pull-up resistor built in (Semi-custom)			Device Orientation :
② ③	Integer	Output Voltage : e.g. 3.0V = ② : 3, ③ : 0	⑥	R	Embossed Tape : Standard Feed
				L	Embossed Tape : Reverse Feed

XC6212 Series

High Speed LDO Regulators, Low ESR Cap. Compatible, Output ON/OFF Control

PACKAGING INFORMATION

- SOT-25 (SOT-23-5)

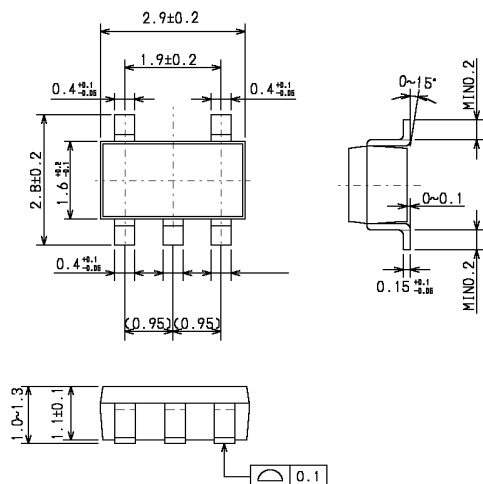

MARKING RULE

- SOT-25 (SOT-23-5)

① Represents product series

SYMBOL	PRODUCT SERIES
9	XC6212xxxxMx

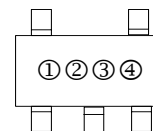

SOT-25 (SOT-23-5)
(TOP VIEW)

② Represents the type of voltage regulator

SYMBOL				PRODUCT SERIES
VOUT 100mV STEPS		VOUT 50mV STEPS		
VOUT=0.1~3.0V	VOUT=3.1~6.0V	VOUT=0.15~3.05V	VOUT=3.15~6.05V	
V	A	E	L	XC6212AxxxMx
X	B	F	M	XC6212BxxxMx
Y	C	H	N	XC6212CxxxMx
Z	D	K	P	XC6212DxxxMx

③ Represents output voltage

SYMBOL	OUTPUT VOLTAGE (V)				SYMBOL	OUTPUT VOLTAGE (V)			
0	-	3.10	-	3.15	F	1.60	4.60	1.65	4.65
1	-	3.20	-	3.25	H	1.70	4.70	1.75	4.75
2	-	3.30	-	3.35	K	1.80	4.80	1.85	4.85
3	-	3.40	-	3.45	L	1.90	4.90	1.95	4.95
4	-	3.50	-	3.55	M	2.00	5.00	2.05	5.05
5	-	3.60	-	3.65	N	2.10	5.10	2.15	5.15
6	-	3.70	-	3.75	P	2.20	5.20	2.25	5.25
7	-	3.80	-	3.85	R	2.30	5.30	2.35	5.35
8	0.90	3.90	0.95	3.95	S	2.40	5.40	2.45	5.45
9	1.00	4.00	1.05	4.05	T	2.50	5.50	2.55	5.55
A	1.10	4.10	1.15	4.15	U	2.60	5.60	2.65	5.65
B	1.20	4.20	1.25	4.25	V	2.70	5.70	2.75	5.75
C	1.30	4.30	1.35	4.35	X	2.80	5.80	2.85	5.85
D	1.40	4.40	1.45	4.45	Y	2.90	5.90	2.95	5.95
E	1.50	4.50	1.55	4.55	Z	3.00	6.00	3.05	-

④ Represents production lot number

0 to 9, A to Z, reversed character of 0 to 9 and A to Z repeated (G,I,J,O,Q excepted)

XC6212 Series

High Speed LDO Regulators, Low ESR Cap. Compatible, Output ON/OFF Control

■ ABSOLUTE MAXIMUM RATINGS

PARAMETER	SYMBOL	RATINGS	UNITS
Input Voltage	VIN	12	V
Output Current	IOUT	500	mA
Output Voltage	VOUT	VSS -0.3 ~ VIN +0.3	V
CE Input Voltage	VCE	VSS -0.3 ~ VIN +0.3	V
Power Dissipation	Pd	250	mW
	SOT-23-5		
Operating Ambient Temperature	Topr	-40 ~ +85	°C
Storage Temperature	Tstg	-55 ~ +125	°C

■ ELECTRICAL CHARACTERISTICS

XC6212B SERIES

Ta=25°C

PARAMETER	SYMBOL	CONDITIONS	MIN	TYP.	MAX	UNITS	CIRCUIT
Output Voltage	VOUT (E)	IOUT=30mA	× 0.98	VOUT(T)	× 1.02	V	①
Maximum Output Current	IOUTMAX		150			mA	①
Load Regulation	ΔVOUT	1mA ≤ IOUT ≤ 100mA		15	50	mV	①
Dropout Voltage	Vdif1	IOUT=30mA	E-1 (page 5)			mV	①
	Vdif2	IOUT=100mA	E-2 (page 5)			mV	
Supply Current	IDD	VCE=VIN		25	50	μA	②
Standby Current	Istby	VCE=VSS		0.01	0.10	μA	②
Line Regulation	$\frac{\Delta VOUT}{\Delta VIN \cdot VOUT}$	VOUT(T)+1.0V ≤ VIN ≤ 10V		0.01	0.20	% / V	①
		IOUT=30mA					
Input Voltage	VIN		2		10	V	-
Output Voltage Temperature Characteristics	$\frac{\Delta VOUT}{\Delta Topr \cdot VOUT}$	IOUT=30mA		100		ppm/°C	①
		-40°C ≤ Topr ≤ 85°C					
Ripple Rejection Rate	PSRR	IOUT=50mA, f=10kHz		70		dB	④
Current Limiter	Ilim			300		mA	①
Short-circuit Current	Ishort			50		mA	①
CE "High" Voltage	VCEH		1.60		VIN	V	①
CE "Low" Voltage	VCEL				0.25	V	②
CE "High" Current	ICEH	VCE=VIN	-0.10		0.10	μA	②
CE "Low" Current	ICEL	VCE=VSS	-0.10		0.10	μA	②

(NOTE 1) VOUT(T)=Specified Output Voltage

(NOTE 2) VOUT(E)=Effective Output Voltage

(I.e. the output voltage when "VOUT(T)+1.0V" is provided at the VIN pin while maintaining a certain IOUT value).

(NOTE 3) $Vdif = \{VIN1^{(NOTE5)} - VOUT1^{(NOTE4)}\}$

(NOTE 4) VOUT1=A voltage equal to 98% of the Output Voltage whenever an amply stabilized IOUT {VOUT(T)+1.0V} is input.

(NOTE 5) VIN1=The Input Voltage when VOUT1 appears as Input Voltage is gradually decreased.

(NOTE 6) Unless otherwise stated, VIN=VOUT(T)+1.0V

XC6212 Series

High Speed LDO Regulators, Low ESR Cap. Compatible, Output ON/OFF Control

■ DROPOUT VOLTAGE

SYMBOL PARAMETER	E-1			E-2		
	Vdif 1			Vdif 2		
	MIN	TYP	MAX	MIN	TYP	MAX
OUTPUT VOLTAGE						
0.9	1100	1100	1110	1100	1150	1200
1.5	500	500	510	500	550	600
1.8	200	200	210	200	300	400
1.9	100	120	150	100	280	380
2.0	-	80	120	-	240	350
2.1 ~ 2.2	-	80	120	-	240	330
2.3 ~ 2.4	-	80	120	-	240	310
2.5 ~ 2.7	-	70	100	-	220	290
2.8 ~ 2.9	-	70	100	-	220	270
3.0	-	60	90	-	200	270
3.1 ~ 3.9	-	60	90	-	200	250
4.0 ~ 4.9	-	60	80	-	180	230
5.0 ~ 6.0	-	50	70	-	160	210

* The input voltage 2.0V (Min.) is needed to operate the series. When the output voltage is less than 2.0V, 2.0V-VOUT(T) of dropout voltage is needed at minimum.

XC6212 Series

High Speed LDO Regulators, Low ESR Cap. Compatible, Output ON/OFF Control

TEST CIRCUITS

Circuit ①

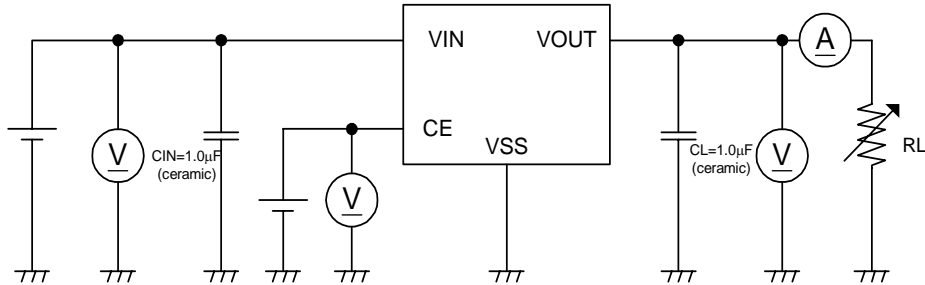

Circuit ②

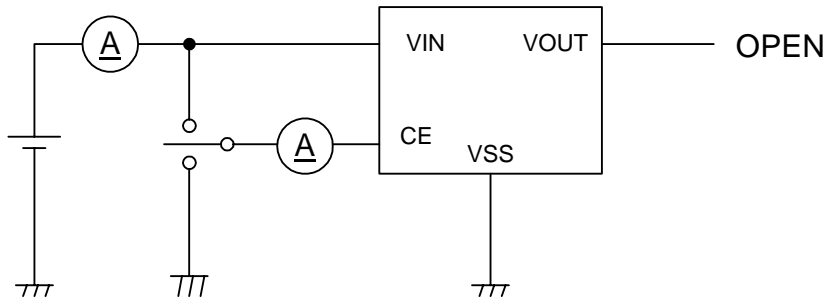

Circuit ③

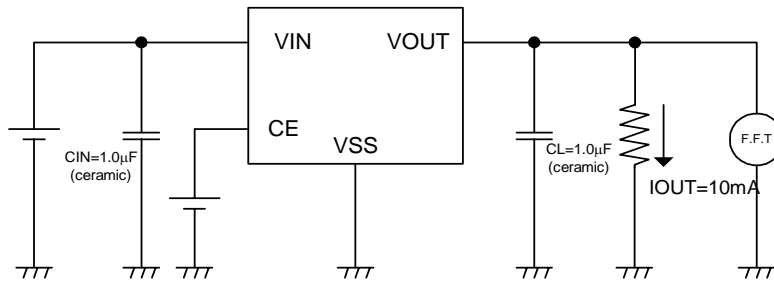

Circuit ④

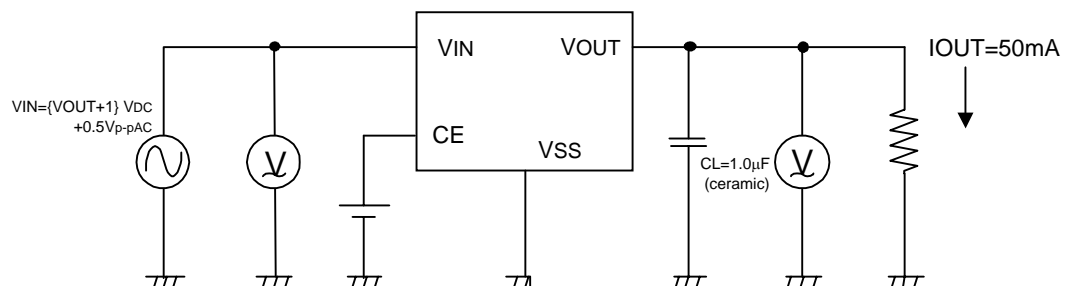

XC6212 Series

High Speed LDO Regulators, Low ESR Cap. Compatible, Output ON/OFF Control

■ OPERATIONAL EXPLANATION

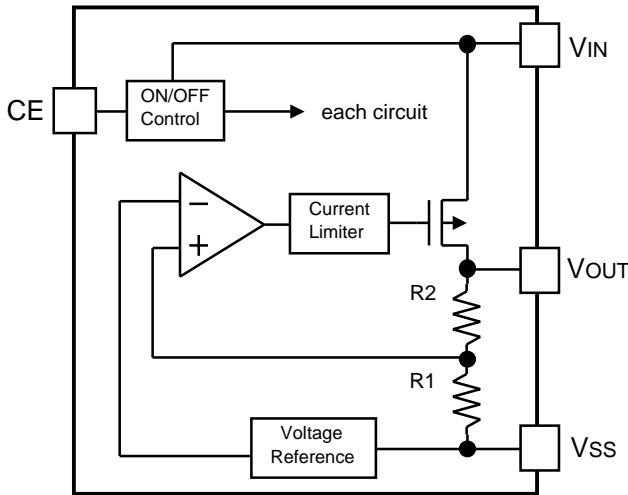

Output voltage control with the XC6212 series :

The voltage divided by resistors R1 & R2 is compared with the internal reference voltage by the error amplifier.

The P-Channel MOSFET, which is connected to the VOUT pin, is then driven by the subsequent output signal. The output voltage at the VOUT pin is controlled & stabilized by a system of negative feedback.

The current limit circuit and short protect circuit operate in relation to the level of output current. Further, the IC's internal circuitry can be shutdown via the CE pin's signal.

Low ESR Capacitors

With the XC6212 series, a stable output voltage is achievable even if used with low ESR capacitors as a phase compensation circuit is built-in. In order to ensure the effectiveness of the phase compensation, we suggest that an output capacitor (CL) is connected as close as possible to the output pin (VOUT) and the VSS pin. Please use an output capacitor with a capacitance value of at least 1 μ F. Also, please connect an input capacitor (CIN) of 0.1 μ F between the VIN pin and the VSS pin in order to ensure a stable power input.

Current Limiter, Short-Circuit Protection

The XC6212 series includes a combination of a fixed current limiter circuit & a foldback circuit which aid the operations of the current limiter and circuit protection. When the load current reaches the current limit level, the fixed current limiter circuit operates and output voltage drops. As a result of this drop in output voltage, the foldback circuit operates, output voltage drops further and output current decreases. When the output pin is shorted, a current of about 50mA flows.

CE Pin

The IC's internal circuitry can be shutdown via the signal from the CE pin with the XC6212 series. In shutdown mode, output at the VOUT pin will be pulled down to the VSS level via R1 & R2. The operational logic of the IC's CE pin is selectable (please refer to the selection guide on page 3). Note that as the standard XC6212B Type is 'Active High/No Pull Down', operations will become unstable with the CE pin open. Although the CE pin is equal to an inverter input with CMOS hysteresis, with either the pull-up or pull-down options, the CE pin input current will increase when the IC is in operation. We suggest that you use this IC with either a VIN voltage or a VSS voltage input at the CE pin. If this IC is used with the correct specifications for the CE pin, the IC will operate normally. However, supply current may increase as a result of through current in the IC's internal circuitry.

■ NOTES on USE

- 1 Please use this IC within the stated absolute maximum ratings.
The IC is liable to malfunction should the ratings be exceeded.
- 2 Where wiring impedance is high, operations may become unstable due to noise and/or phase lag depending on output current. Please strengthen VIN and VSS wiring in particular.
- 3 Please wire the input capacitor (CIN) and the output capacitor (CL) as close to the IC as possible.