



MOTOROLA

Three-Terminal Negative Voltage Regulators

The MC7900 series of fixed output negative voltage regulators are intended as complements to the popular MC7800 series devices. These negative regulators are available in the same seven-voltage options as the MC7800 devices. In addition, one extra voltage option commonly employed in MECL systems is also available in the negative MC7900 series.

Available in fixed output voltage options from -5.0 V to -24 V, these regulators employ current limiting, thermal shutdown, and safe-area compensation - making them remarkably rugged under most operating conditions. With adequate heatsinking they can deliver output currents in excess of 1.0 A.

- No External Components Required
- Internal Thermal Overload Protection
- Internal Short Circuit Current Limiting
- Output Transistor Safe-Area Compensation
- Available in 2% Voltage Tolerance (See Ordering Information)

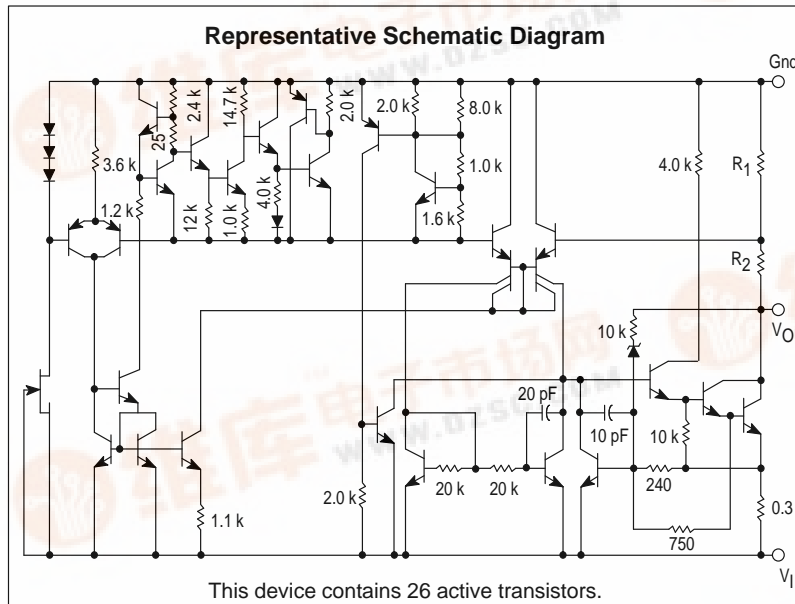

ORDERING INFORMATION

Device	Output Voltage Tolerance	Operating Temperature Range	Package
MC79XXACD2T	2%	$T_J = 0^\circ \text{ to } +125^\circ\text{C}$	Surface Mount
MC79XXCD2T	4%		
MC79XXACT	2%		Insertion Mount
MC79XXCT	4%		
MC79XXBD2T	4%	$T_J = -40^\circ \text{ to } +125^\circ\text{C}$	Surface Mount
MC79XXBT			Insertion Mount

XX indicates nominal voltage.

MC7900 Series

THREE-TERMINAL NEGATIVE FIXED VOLTAGE REGULATORS

T SUFFIX
PLASTIC PACKAGE
CASE 221A

Heatsink surface connected to Pin 2.

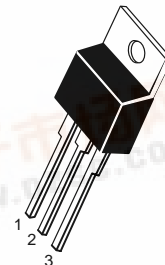

Pin 1. Ground
Pin 2. Input
Pin 3. Output

D2T SUFFIX
PLASTIC PACKAGE
CASE 936
(D²PAK)

Heatsink surface (shown as terminal 4 in case outline drawing) is connected to Pin 2.

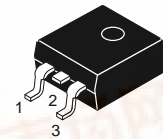

STANDARD APPLICATION

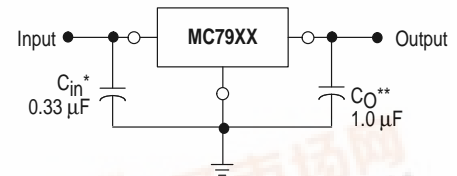

A common ground is required between the input and the output voltages. The input voltage must remain typically 2.0 V above more negative even during the high point of the input ripple voltage.

XX, These two digits of the type number indicate nominal voltage.

* C_{in} is required if regulator is located an appreciable distance from power supply filter.

** C_O improve stability and transient response.

DEVICE TYPE/NOMINAL OUTPUT VOLTAGE

MC7905	5.0 V	MC7912	12 V
MC7905.2	5.2 V	MC7915	15 V
MC7906	6.0 V	MC7918	28 V
MC7908	8.0 V	MC7924	24 V

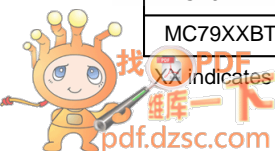

MC7900

MAXIMUM RATINGS (T_A = +25°C, unless otherwise noted.)

Rating	Symbol	Value	Unit
Input Voltage (−5.0 V ≥ V _O ≥ −18 V) (24 V)	V _I	−35 −40	Vdc
Power Dissipation Case 221A T _A = +25°C Thermal Resistance, Junction-to-Ambient Thermal Resistance, Junction-to-Case Case 936 (D ² PAK) T _A = +25°C Thermal Resistance, Junction-to-Ambient Thermal Resistance, Junction-to-Case	P _D θ _{JA} θ _{JC} P _D θ _{JA} θ _{JC}	Internally Limited 65 5.0 Internally Limited 70 5.0	W °C/W °C/W W °C/W °C/W
Storage Junction Temperature Range	T _{stg}	−65 to +150	°C
Junction Temperature	T _J	+150	°C

THERMAL CHARACTERISTICS

Characteristics	Symbol	Max	Unit
Thermal Resistance, Junction-to-Ambient	R _{θJA}	65	°C/W
Thermal Resistance, Junction-to-Case	R _{θJC}	5.0	°C/W

MC7905C

ELECTRICAL CHARACTERISTICS (V_I = −10 V, I_O = 500 mA, 0°C < T_J < +125°C, unless otherwise noted.)

Characteristics	Symbol	Min	Typ	Max	Unit
Output Voltage (T _J = +25°C)	V _O	−4.8	−5.0	−5.2	Vdc
Line Regulation (Note 1) (T _J = +25°C, I _O = 100 mA) −7.0 Vdc ≥ V _I ≥ −25 Vdc −8.0 Vdc ≥ V _I ≥ −12 Vdc (T _J = +25°C, I _O = 500 mA) −7.0 Vdc ≥ V _I ≥ −25 Vdc −8.0 Vdc ≥ V _I ≥ −12 Vdc	Reg _{line}	– –	7.0 2.0	50 25	mV
Load Regulation, T _J = +25°C (Note 1) 5.0 mA ≤ I _O ≤ 1.5 A 250 mA ≤ I _O ≤ 750 mA	Reg _{load}	– –	11 4.0	100 50	mV
Output Voltage −7.0 Vdc ≥ V _I ≥ −20 Vdc, 5.0 mA ≤ I _O ≤ 1.0 A, P ≤ 15 W	V _O	−4.75	–	−5.25	Vdc
Input Bias Current (T _J = +25°C)	I _{IB}	–	4.3	8.0	mA
Input Bias Current Change −7.0 Vdc ≥ V _I ≥ −25 Vdc 5.0 mA ≤ I _O ≤ 1.5 A	ΔI _{IB}	– –	– –	1.3 0.5	mA
Output Noise Voltage (T _A = +25°C, 10 Hz ≤ f ≤ 100 kHz)	V _n	–	40	–	μV
Ripple Rejection (I _O = 20 mA, f = 120 Hz)	RR	–	70	–	dB
Dropout Voltage I _O = 1.0 A, T _J = +25°C	V _I −V _O	–	2.0	–	Vdc
Average Temperature Coefficient of Output Voltage I _O = 5.0 mA, 0°C ≤ T _J ≤ +125°C	ΔV _O /ΔT	–	−1.0	–	mV/°C

NOTE: 1. Load and line regulation are specified at constant junction temperature. Changes in V_O due to heating effects must be taken into account separately. Pulse testing with low duty cycle is used.

MC7900

MC7905AC

ELECTRICAL CHARACTERISTICS ($V_I = -10\text{ V}$, $I_O = 500\text{ mA}$, $0^\circ\text{C} < T_J < +125^\circ\text{C}$, unless otherwise noted.)

Characteristics	Symbol	Min	Typ	Max	Unit
Output Voltage ($T_J = +25^\circ\text{C}$)	V_O	-4.9	-5.0	-5.1	Vdc
Line Regulation (Note 1) -8.0 Vdc $\geq V_I \geq -12\text{ Vdc}$; $I_O = 1.0\text{ A}$, $T_J = +25^\circ\text{C}$ -8.0 Vdc $\geq V_I \geq -12\text{ Vdc}$; $I_O = 1.0\text{ A}$ -7.5 Vdc $\geq V_I \geq -25\text{ Vdc}$; $I_O = 500\text{ mA}$ -7.0 Vdc $\geq V_I \geq -20\text{ Vdc}$; $I_O = 1.0\text{ A}$, $T_J = +25^\circ\text{C}$	Reg _{line}	-	2.0 7.0 7.0 6.0	25 50 50 50	mV
Load Regulation (Note 1) 5.0 mA $\leq I_O \leq 1.5\text{ A}$, $T_J = +25^\circ\text{C}$ 250 mA $\leq I_O \leq 750\text{ mA}$ 5.0 mA $\leq I_O \leq 1.0\text{ A}$	Reg _{load}	-	11 4.0 9.0	100 50 100	mV
Output Voltage -7.5 Vdc $\geq V_I \geq -20\text{ Vdc}$, 5.0 mA $\leq I_O \leq 1.0\text{ A}$, $P \leq 15\text{ W}$	V_O	-4.80	-	-5.20	Vdc
Input Bias Current	I_{IB}	-	4.4	8.0	mA
Input Bias Current Change -7.5 Vdc $\geq V_I \geq -25\text{ Vdc}$ 5.0 mA $\leq I_O \leq 1.0\text{ A}$ 5.0 mA $\leq I_O \leq 1.5\text{ A}$, $T_J = +25^\circ\text{C}$	ΔI_{IB}	-	-	1.3 0.5 0.5	mA
Output Noise Voltage ($T_A = +25^\circ\text{C}$, 10 Hz $\leq f \leq 100\text{ kHz}$)	V_n	-	40	-	μV
Ripple Rejection ($I_O = \text{mA}$, $f = 120\text{ Hz}$)	RR	-	70	-	dB
Dropout Voltage $I_O = 1.0\text{ A}$, $T_J = +25^\circ\text{C}$	$V_I - V_O$	-	2.0	-	Vdc
Average Temperature Coefficient of Output Voltage $I_O = 5.0\text{ mA}$, $0^\circ\text{C} \leq T_J \leq +125^\circ\text{C}$	$\Delta V_O / \Delta T$	-	-1.0	-	mV/ $^\circ\text{C}$

MC7905.2C

ELECTRICAL CHARACTERISTICS ($V_I = -10\text{ V}$, $I_O = 500\text{ mA}$, $0^\circ\text{C} < T_J < +125^\circ\text{C}$, unless otherwise noted.)

Characteristics	Symbol	Min	Typ	Max	Unit
Output Voltage ($T_J = +25^\circ\text{C}$)	V_O	-5.0	-5.2	-5.4	Vdc
Line Regulation (Note 1) ($T_J = +25^\circ\text{C}$, $I_O = 100\text{ mA}$) -7.2 Vdc $\geq V_I \geq -25\text{ Vdc}$ -8.0 Vdc $\geq V_I \geq -12\text{ Vdc}$ ($T_J = +25^\circ\text{C}$, $I_O = 500\text{ mA}$) -7.2 Vdc $\geq V_I \geq -25\text{ Vdc}$ -8.0 Vdc $\geq V_I \geq -12\text{ Vdc}$	Reg _{line}	-	8.0 2.2 37 8.5	52 27 105 52	mV
Load Regulation, $T_J = +25^\circ\text{C}$ (Note 1) 5.0 mA $\leq I_O \leq 1.5\text{ A}$ 250 mA $\leq I_O \leq 750\text{ mA}$	Reg _{load}	-	12 4.5	105 52	mV
Output Voltage -7.2 Vdc $\geq V_I \geq -20\text{ Vdc}$, 5.0 mA $\leq I_O \leq 1.0\text{ A}$, $P \leq 15\text{ W}$	V_O	-4.95	-	-5.45	Vdc
Input Bias Current ($T_J = +25^\circ\text{C}$)	I_{IB}	-	4.3	8.0	mA
Input Bias Current Change -7.2 Vdc $\geq V_I \geq -25\text{ Vdc}$ 5.0 mA $\leq I_O \leq 1.5\text{ A}$	ΔI_{IB}	-	-	1.3 0.5	mA
Output Noise Voltage ($T_A = +25^\circ\text{C}$, 10 Hz $\leq f \leq 100\text{ kHz}$)	V_n	-	42	-	μV
Ripple Rejection ($I_O = 20\text{ mA}$, $f = 120\text{ Hz}$)	RR	-	68	-	dB
Dropout Voltage $I_O = 1.0\text{ A}$, $T_J = +25^\circ\text{C}$	$V_I - V_O$	-	2.0	-	Vdc
Average Temperature Coefficient of Output Voltage $I_O = 5.0\text{ mA}$, $0^\circ\text{C} \leq T_J \leq +125^\circ\text{C}$	$\Delta V_O / \Delta T$	-	-1.0	-	mV/ $^\circ\text{C}$

NOTE: 1. Load and line regulation are specified at constant junction temperature. Changes in V_O due to heating effects must be taken into account separately. Pulse testing with low duty cycle is used.

MC7900

MC7906C

ELECTRICAL CHARACTERISTICS ($V_I = -11\text{ V}$, $I_O = 500\text{ mA}$, $0^\circ\text{C} < T_J < +125^\circ\text{C}$, unless otherwise noted.)

Characteristics	Symbol	Min	Typ	Max	Unit
Output Voltage ($T_J = +25^\circ\text{C}$)	V_O	-5.75	-6.0	-6.25	Vdc
Line Regulation (Note 1) ($T_J = +25^\circ\text{C}$, $I_O = 100\text{ mA}$) -8.0 Vdc $\geq V_I \geq -25\text{ Vdc}$ -9.0 Vdc $\geq V_I \geq -13\text{ Vdc}$ ($T_J = +25^\circ\text{C}$, $I_O = 500\text{ mA}$) -8.0 Vdc $\geq V_I \geq -25\text{ Vdc}$ -9.0 Vdc $\geq V_I \geq -13\text{ Vdc}$	Reg _{line}	-	9.0 3.0	60 30	mV
Load Regulation, $T_J = +25^\circ\text{C}$ (Note 1) $5.0\text{ mA} \leq I_O \leq 1.5\text{ A}$ $250\text{ mA} \leq I_O \leq 750\text{ mA}$	Reg _{load}	-	13 5.0	120 60	mV
Output Voltage -8.0 Vdc $\geq V_I \geq -21\text{ Vdc}$, $5.0\text{ mA} \leq I_O \leq 1.0\text{ A}$, $P \leq 15\text{ W}$	V_O	-5.7	-	-6.3	Vdc
Input Bias Current ($T_J = +25^\circ\text{C}$)	I_{IB}	-	4.3	8.0	mA
Input Bias Current Change -8.0 Vdc $\geq V_I \geq -25\text{ Vdc}$ $5.0\text{ mA} \leq I_O \leq 1.5\text{ A}$	ΔI_{IB}	-	-	1.3 0.5	mA
Output Noise Voltage ($T_A = +25^\circ\text{C}$, $10\text{ Hz} \leq f \leq 100\text{ kHz}$)	V_n	-	45	-	μV
Ripple Rejection ($I_O = 20\text{ mA}$, $f = 120\text{ Hz}$)	RR	-	65	-	dB
Dropout Voltage $I_O = 1.0\text{ A}$, $T_J = +25^\circ\text{C}$	$V_I - V_O$	-	2.0	-	Vdc
Average Temperature Coefficient of Output Voltage $I_O = 5.0\text{ A}$, $0^\circ\text{C} \leq T_J \leq +125^\circ\text{C}$	$\Delta V_O / \Delta T$	-	-1.0	-	mV/ $^\circ\text{C}$

MC7908C

ELECTRICAL CHARACTERISTICS ($V_I = -14\text{ V}$, $I_O = 500\text{ mA}$, $0^\circ\text{C} < T_J < +125^\circ\text{C}$, unless otherwise noted.)

Characteristics	Symbol	Min	Typ	Max	Unit
Output Voltage ($T_J = +25^\circ\text{C}$)	V_O	-7.7	-8.0	-8.3	Vdc
Line Regulation (Note 1) ($T_J = +25^\circ\text{C}$, $I_O = 100\text{ mA}$) -10.5 Vdc $\geq V_I \geq -25\text{ Vdc}$ -11 Vdc $\geq V_I \geq -17\text{ Vdc}$ ($T_J = +25^\circ\text{C}$, $I_O = 500\text{ mA}$) -10.5 Vdc $\geq V_I \geq -25\text{ Vdc}$ -11 Vdc $\geq V_I \geq -17\text{ Vdc}$	Reg _{line}	-	12 5.0	80 40	mV
Load Regulation, $T_J = +25^\circ\text{C}$ (Note 1) $5.0\text{ mA} \leq I_O \leq 1.5\text{ A}$ $250\text{ mA} \leq I_O \leq 750\text{ mA}$	Reg _{load}	-	26 9.0	160 80	mV
Output Voltage -10.5 Vdc $\geq V_I \geq -23\text{ Vdc}$, $5.0\text{ mA} \leq I_O \leq 1.0\text{ A}$, $P \leq 15\text{ W}$	V_O	-7.6	-	-8.4	Vdc
Input Bias Current ($T_J = +25^\circ\text{C}$)	I_{IB}	-	4.3	8.0	mA
Input Bias Current Change -10.5 Vdc $\geq V_I \geq -25\text{ Vdc}$ $5.0\text{ mA} \leq I_O \leq 1.5\text{ A}$	ΔI_{IB}	-	-	1.0 0.5	mA
Output Noise Voltage ($T_A = +25^\circ\text{C}$, $10\text{ Hz} \leq f \leq 100\text{ kHz}$)	V_n	-	52	-	μV
Ripple Rejection ($I_O = 20\text{ mA}$, $f = 120\text{ Hz}$)	RR	-	62	-	dB
Dropout Voltage $I_O = 1.0\text{ A}$, $T_J = +25^\circ\text{C}$	$V_I - V_O$	-	2.0	-	Vdc
Average Temperature Coefficient of Output Voltage $I_O = 5.0\text{ mA}$, $0^\circ\text{C} \leq T_J \leq +125^\circ\text{C}$	$\Delta V_O / \Delta T$	-	-1.0	-	mV/ $^\circ\text{C}$

NOTE: 1. Load and line regulation are specified at constant junction temperature. Changes in V_O due to heating effects must be taken into account separately. Pulse testing with low duty cycle is used.

MC7900

MC7912C

ELECTRICAL CHARACTERISTICS ($V_I = -19\text{ V}$, $I_O = 500\text{ mA}$, $0^\circ\text{C} < T_J < +125^\circ\text{C}$, unless otherwise noted.)

Characteristics	Symbol	Min	Typ	Max	Unit
Output Voltage ($T_J = +25^\circ\text{C}$)	V_O	-11.5	-12	-12.5	Vdc
Line Regulation (Note 1) ($T_J = +25^\circ\text{C}$, $I_O = 100\text{ mA}$) -14.5 Vdc $\geq V_I \geq -30\text{ Vdc}$ -16 Vdc $\geq V_I \geq -22\text{ Vdc}$ ($T_J = +25^\circ\text{C}$, $I_O = 500\text{ mA}$) -14.5 Vdc $\geq V_I \geq -30\text{ Vdc}$ -16 Vdc $\geq V_I \geq -22\text{ Vdc}$	Regline	-	13 6.0	120 60	mV
Load Regulation, $T_J = +25^\circ\text{C}$ (Note 1) $5.0\text{ mA} \leq I_O \leq 1.5\text{ A}$ $250\text{ mA} \leq I_O \leq 750\text{ mA}$	Regload	-	46 17	240 120	mV
Output Voltage -14.5 Vdc $\geq V_I \geq -27\text{ Vdc}$, $5.0\text{ mA} \leq I_O \leq 1.0\text{ A}$, $P \leq 15\text{ W}$	V_O	-11.4	-	-12.6	Vdc
Input Bias Current ($T_J = +25^\circ\text{C}$)	I_{IB}	-	4.4	8.0	mA
Input Bias Current Change -14.5 Vdc $\geq V_I \geq -30\text{ Vdc}$ $5.0\text{ mA} \leq I_O \leq 1.5\text{ A}$	ΔI_{IB}	-	-	1.0 0.5	mA
Output Noise Voltage ($T_A = +25^\circ\text{C}$, $10\text{ Hz} \leq f \leq 100\text{ kHz}$)	V_n	-	75	-	μV
Ripple Rejection ($I_O = 20\text{ mA}$, $f = 120\text{ Hz}$)	RR	-	61	-	dB
Dropout Voltage $I_O = 1.0\text{ A}$, $T_J = +25^\circ\text{C}$	$V_I - V_O$	-	2.0	-	Vdc
Average Temperature Coefficient of Output Voltage $I_O = 5.0\text{ mA}$, $0^\circ\text{C} \leq T_J \leq +125^\circ\text{C}$	$\Delta V_O / \Delta T$	-	-1.0	-	$\text{mV}/^\circ\text{C}$

MC7912AC

ELECTRICAL CHARACTERISTICS ($V_I = -19\text{ V}$, $I_O = 500\text{ mA}$, $0^\circ\text{C} < T_J < +125^\circ\text{C}$, unless otherwise noted.)

Characteristics	Symbol	Min	Typ	Max	Unit
Output Voltage ($T_J = +25^\circ\text{C}$)	V_O	-11.75	-12	-12.25	Vdc
Line Regulation (Note 1) -16 Vdc $\geq V_I \geq -22\text{ Vdc}$; $I_O = 1.0\text{ A}$, $T_J = +25^\circ\text{C}$ -16 Vdc $\geq V_I \geq -22\text{ Vdc}$; $I_O = 1.0\text{ A}$ -14.8 Vdc $\geq V_I \geq -30\text{ Vdc}$; $I_O = 500\text{ mA}$ -14.5 Vdc $\geq V_I \geq -27\text{ Vdc}$; $I_O = 1.0\text{ A}$, $T_J = +25^\circ\text{C}$	Regline	-	6.0 24 24 13	60 120 120 120	mV
Load Regulation (Note 1) $5.0\text{ mA} \leq I_O \leq 1.5\text{ A}$, $T_J = +25^\circ\text{C}$ $250\text{ mA} \leq I_O \leq 750\text{ mA}$ $5.0\text{ mA} \leq I_O \leq 1.0\text{ A}$	Regload	-	46 17 35	150 75 150	mV
Output Voltage -14.8 Vdc $\geq V_I \geq -27\text{ Vdc}$, $5.0\text{ mA} \leq I_O \leq 1.0\text{ A}$, $P \leq 15\text{ W}$	V_O	-11.5	-	-12.5	Vdc
Input Bias Current	I_{IB}	-	4.4	8.0	mA
Input Bias Current Change -15 Vdc $\geq V_I \geq -30\text{ Vdc}$ $5.0\text{ mA} \leq I_O \leq 1.0\text{ A}$ $5.0\text{ mA} \leq I_O \leq 1.5\text{ A}$, $T_J = +25^\circ\text{C}$	ΔI_{IB}	-	-	0.8 0.5 0.5	mA
Output Noise Voltage ($T_A = +25^\circ\text{C}$, $10\text{ Hz} \leq f \leq 100\text{ kHz}$)	V_n	-	75	-	μV
Ripple Rejection ($I_O = 20\text{ mA}$, $f = 120\text{ Hz}$)	RR	-	61	-	dB
Dropout Voltage $I_O = 1.0\text{ A}$, $T_J = +25^\circ\text{C}$	$V_I - V_O$	-	2.0	-	Vdc
Average Temperature Coefficient of Output Voltage $I_O = 5.0\text{ A}$, $0^\circ\text{C} \leq T_J \leq +125^\circ\text{C}$	$\Delta V_O / \Delta T$	-	-1.0	-	$\text{mV}/^\circ\text{C}$

NOTE: 1. Load and line regulation are specified at constant junction temperature. Changes in V_O due to heating effects must be taken into account separately. Pulse testing with low duty cycle is used.

MC7900

MC7915C

ELECTRICAL CHARACTERISTICS ($V_I = -23\text{ V}$, $I_O = 500\text{ mA}$, $0^\circ\text{C} < T_J < +125^\circ\text{C}$, unless otherwise noted.)

Characteristics	Symbol	Min	Typ	Max	Unit
Output Voltage ($T_J = +25^\circ\text{C}$)	V_O	-14.4	-15	-15.6	Vdc
Line Regulation (Note 1) ($T_J = +25^\circ\text{C}$, $I_O = 100\text{ mA}$) -17.5 Vdc $\geq V_I \geq -30\text{ Vdc}$ -20 Vdc $\geq V_I \geq -26\text{ Vdc}$ ($T_J = +25^\circ\text{C}$, $I_O = 500\text{ mA}$) -17.5 Vdc $\geq V_I \geq -30\text{ Vdc}$ -20 Vdc $\geq V_I \geq -26\text{ Vdc}$	Reg _{line}	-	14 6.0	150 75	mV
Load Regulation, $T_J = +25^\circ\text{C}$ (Note 1) 5.0 mA $\leq I_O \leq 1.5\text{ A}$ 250 mA $\leq I_O \leq 750\text{ mA}$	Reg _{load}	-	68 25	300 150	mV
Output Voltage -17.5 Vdc $\geq V_I \geq -30\text{ Vdc}$, 5.0 mA $\leq I_O \leq 1.0\text{ A}$, $P \leq 15\text{ W}$	V_O	-14.25	-	-15.75	Vdc
Input Bias Current ($T_J = +25^\circ\text{C}$)	I_{IB}	-	4.4	8.0	mA
Input Bias Current Change -17.5 Vdc $\geq V_I \geq -30\text{ Vdc}$ 5.0 mA $\leq I_O \leq 1.5\text{ A}$	ΔI_{IB}	-	-	1.0 0.5	mA
Output Noise Voltage ($T_A = +25^\circ\text{C}$, 10 Hz $\leq f \leq 100\text{ kHz}$)	V_n	-	90	-	μV
Ripple Rejection ($I_O = 20\text{ mA}$, $f = 120\text{ Hz}$)	RR	-	60	-	dB
Dropout Voltage $I_O = 1.0\text{ A}$, $T_J = +25^\circ\text{C}$	$V_I - V_O$	-	2.0	-	Vdc
Average Temperature Coefficient of Output Voltage $I_O = 5.0\text{ A}$, $0^\circ\text{C} \leq T_J \leq +125^\circ\text{C}$	$\Delta V_O / \Delta T$	-	-1.0	-	mV/ $^\circ\text{C}$

MC7915AC

ELECTRICAL CHARACTERISTICS ($V_I = -23\text{ V}$, $I_O = 500\text{ mA}$, $0^\circ\text{C} < T_J < +125^\circ\text{C}$, unless otherwise noted.)

Characteristics	Symbol	Min	Typ	Max	Unit
Output Voltage ($T_J = +25^\circ\text{C}$)	V_O	-14.7	-15	-15.3	Vdc
Line Regulation (Note 1) -20 Vdc $\geq V_I \geq -26\text{ Vdc}$, $I_O = 1.0\text{ A}$, $T_J = +25^\circ\text{C}$ -20 Vdc $\geq V_I \geq -26\text{ Vdc}$, $I_O = 1.0\text{ A}$, -17.9 Vdc $\geq V_I \geq -30\text{ Vdc}$, $I_O = 500\text{ mA}$ -17.5 Vdc $\geq V_I \geq -30\text{ Vdc}$, $I_O = 1.0\text{ A}$, $T_J = +25^\circ\text{C}$	Reg _{line}	-	27 57 57 57	75 150 150 150	mV
Load Regulation (Note 1) 5.0 mA $\leq I_O \leq 1.5\text{ A}$, $T_J = +25^\circ\text{C}$ 250 mA $\leq I_O \leq 750\text{ mA}$ 5.0 mA $\leq I_O \leq 1.0\text{ A}$	Reg _{load}	-	68 25 40	150 75 150	mV
Output Voltage -17.9 Vdc $\geq V_I \geq -30\text{ Vdc}$, 5.0 mA $\leq I_O \leq 1.0\text{ A}$, $P \leq 15\text{ W}$	V_O	-14.4	-	-15.6	Vdc
Input Bias Current	I_{IB}	-	4.4	8.0	mA
Input Bias Current Change -17.5 Vdc $\geq V_I \geq -30\text{ Vdc}$ 5.0 mA $\leq I_O \leq 1.0\text{ A}$ 5.0 mA $\leq I_O \leq 1.5\text{ A}$, $T_J = +25^\circ\text{C}$	ΔI_{IB}	-	-	0.8 0.5 0.5	mA
Output Noise Voltage ($T_A = +25^\circ\text{C}$, 10 Hz $\leq f \leq 100\text{ kHz}$)	V_n	-	90	-	μV
Ripple Rejection ($I_O = 20\text{ mA}$, $f = 120\text{ Hz}$)	RR	-	60	-	dB
Dropout Voltage $I_O = 1.0\text{ A}$, $T_J = +25^\circ\text{C}$	$V_I - V_O$	-	2.0	-	Vdc
Average Temperature Coefficient of Output Voltage $I_O = 5.0\text{ mA}$, $0^\circ\text{C} \leq T_J \leq +125^\circ\text{C}$	$\Delta V_O / \Delta T$	-	-1.0	-	mV/ $^\circ\text{C}$

NOTE: 1. Load and line regulation are specified at constant junction temperature. Changes in V_O due to heating effects must be taken into account separately. Pulse testing with low duty cycle is used.

MC7900

MC7918C

ELECTRICAL CHARACTERISTICS ($V_I = -27\text{ V}$, $I_O = 500\text{ mA}$, $0^\circ\text{C} < T_J < +125^\circ\text{C}$, unless otherwise noted.)

Characteristics	Symbol	Min	Typ	Max	Unit
Output Voltage ($T_J = +25^\circ\text{C}$)	V_O	-17.3	-18	-18.7	Vdc
Line Regulation (Note 1) ($T_J = +25^\circ\text{C}$, $I_O = 100\text{ mA}$) -21 Vdc $\geq V_I \geq -33\text{ Vdc}$ -24 Vdc $\geq V_I \geq -30\text{ Vdc}$ ($T_J = +25^\circ\text{C}$, $I_O = 500\text{ mA}$) -21 Vdc $\geq V_I \geq -33\text{ Vdc}$ -24 Vdc $\geq V_I \geq -30\text{ Vdc}$	Reg _{line}	-	25 10	180 90	mV
Load Regulation, $T_J = +25^\circ\text{C}$ (Note 1) $5.0\text{ mA} \leq I_O \leq 1.5\text{ A}$ $250\text{ mA} \leq I_O \leq 750\text{ mA}$	Reg _{load}	-	110 55	360 180	mV
Output Voltage -21 Vdc $\geq V_I \geq -33\text{ Vdc}$, $5.0\text{ mA} \leq I_O \leq 1.0\text{ A}$, $P \leq 15\text{ W}$	V_O	-17.1	-	-18.9	Vdc
Input Bias Current ($T_J = +25^\circ\text{C}$)	I_{IB}	-	4.5	8.0	mA
Input Bias Current Change -21 Vdc $\geq V_I \geq -33\text{ Vdc}$ $5.0\text{ mA} \leq I_O \leq 1.5\text{ A}$	ΔI_{IB}	-	-	1.0 0.5	mA
Output Noise Voltage ($T_A = +25^\circ\text{C}$, $10\text{ Hz} \leq f \leq 100\text{ kHz}$)	V_n	-	110	-	μV
Ripple Rejection ($I_O = 20\text{ mA}$, $f = 120\text{ Hz}$)	RR	-	59	-	dB
Dropout Voltage $I_O = 1.0\text{ A}$, $T_J = +25^\circ\text{C}$	$V_I - V_O$	-	2.0	-	Vdc
Average Temperature Coefficient of Output Voltage $I_O = 5.0\text{ mA}$, $0^\circ\text{C} \leq T_J \leq +125^\circ\text{C}$	$\Delta V_O / \Delta T$	-	-1.0	-	mV/ $^\circ\text{C}$

MC7924C

ELECTRICAL CHARACTERISTICS ($V_I = -33\text{ V}$, $I_O = 500\text{ mA}$, $0^\circ\text{C} < T_J < +125^\circ\text{C}$, unless otherwise noted.)

Characteristics	Symbol	Min	Typ	Max	Unit
Output Voltage ($T_J = +25^\circ\text{C}$)	V_O	-23	-24	-25	Vdc
Line Regulation (Note 1) ($T_J = +25^\circ\text{C}$, $I_O = 100\text{ mA}$) -27 Vdc $\geq V_I \geq -38\text{ Vdc}$ -30 Vdc $\geq V_I \geq -36\text{ Vdc}$ ($T_J = +25^\circ\text{C}$, $I_O = 500\text{ mA}$) -27 Vdc $\geq V_I \geq -38\text{ Vdc}$ -30 Vdc $\geq V_I \geq -36\text{ Vdc}$	Reg _{line}	-	31 14	240 120	mV
Load Regulation, $T_J = +25^\circ\text{C}$ (Note 1) $5.0\text{ mA} \leq I_O \leq 1.5\text{ A}$ $250\text{ mA} \leq I_O \leq 750\text{ mA}$	Reg _{load}	-	150 85	480 240	mV
Output Voltage -27 Vdc $\geq V_I \geq -38\text{ Vdc}$, $5.0\text{ mA} \leq I_O \leq 1.0\text{ A}$, $P \leq 15\text{ W}$	V_O	-22.8	-	-25.2	Vdc
Input Bias Current ($T_J = +25^\circ\text{C}$)	I_{IB}	-	4.6	8.0	mA
Input Bias Current Change -27 Vdc $\geq V_I \geq -38\text{ Vdc}$ $5.0\text{ mA} \leq I_O \leq 1.5\text{ A}$	ΔI_{IB}	-	-	1.0 0.5	mA
Output Noise Voltage ($T_A = +25^\circ\text{C}$, $10\text{ Hz} \leq f \leq 100\text{ kHz}$)	V_n	-	170	-	μV
Ripple Rejection ($I_O = 20\text{ mA}$, $f = 120\text{ Hz}$)	RR	-	56	-	dB
Dropout Voltage $I_O = 1.0\text{ A}$, $T_J = +25^\circ\text{C}$	$V_I - V_O$	-	2.0	-	Vdc
Average Temperature Coefficient of Output Voltage $I_O = 5.0\text{ mA}$, $0^\circ\text{C} \leq T_J \leq +125^\circ\text{C}$	$\Delta V_O / \Delta T$	-	-1.0	-	mV/ $^\circ\text{C}$

NOTE: 1. Load and line regulation are specified at constant junction temperature. Changes in V_O due to heating effects must be taken into account separately. Pulse testing with low duty cycle is used.

MC7900

Figure 1. Worst Case Power Dissipation as a Function of Ambient Temperature

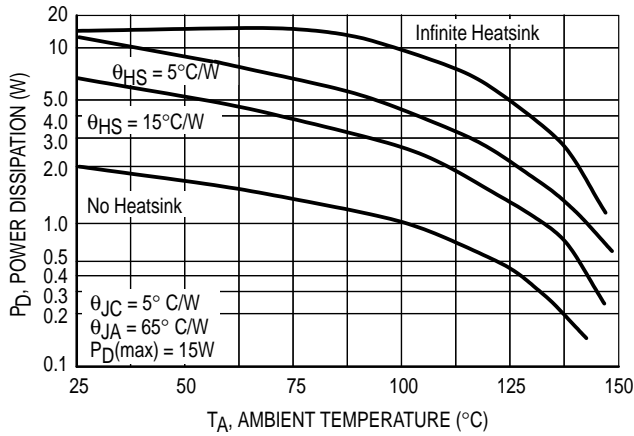

Figure 2. Peak Output Current as a Function of Input-Output Differential Voltage

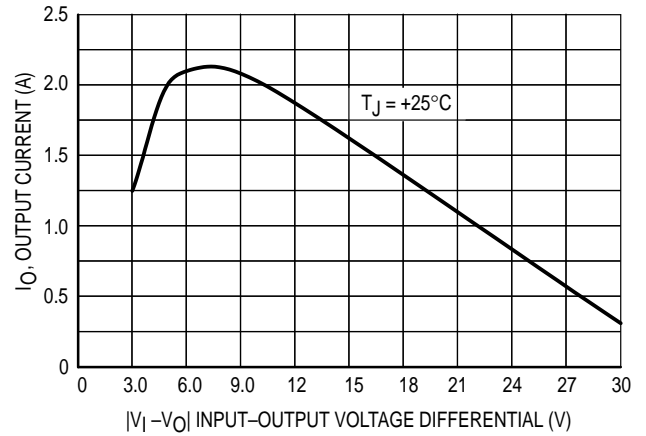

Figure 3. Ripple Rejection as a Function of Frequency

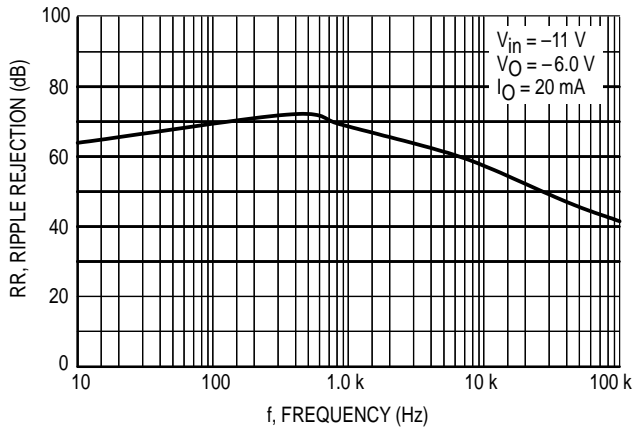

Figure 4. Ripple Rejection as a Function of Output Voltage

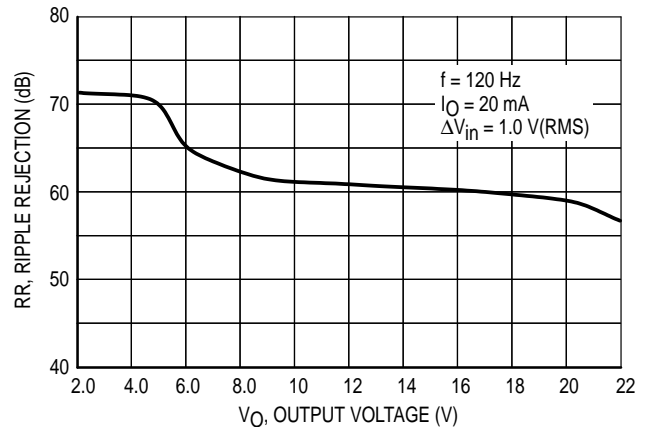

Figure 5. Output Voltage as a Function of Junction Temperature

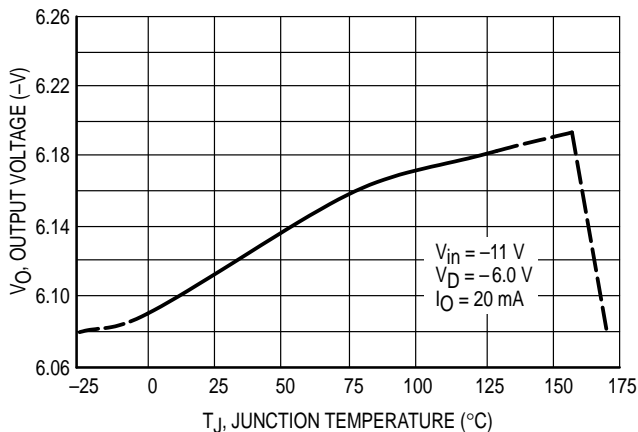
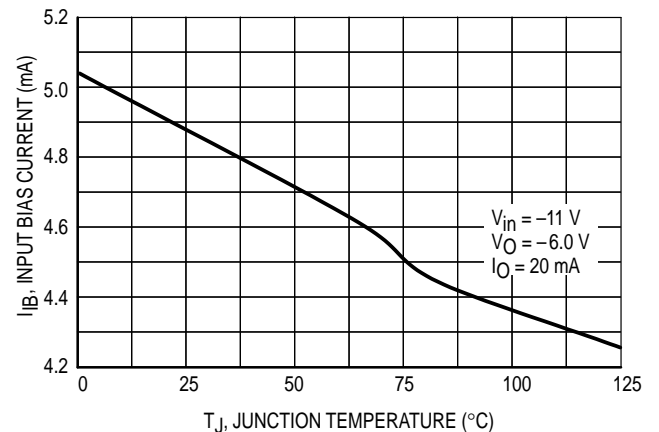

Figure 6. Quiescent Current as a Function of Temperature



MC7900

APPLICATIONS INFORMATION

Design Considerations

The MC7900 Series of fixed voltage regulators are designed with Thermal overload Protection that shuts down the circuit when subjected to an excessive power overload condition. Internal Short Circuit Protection that limits the maximum current the circuit will pass, and Output Transistor Safe-Area Compensation that reduces the output short circuit current as the voltage across the pass transistor is increased.

In many low current applications, compensation capacitors are not required. However, it is recommended that the regulator input be bypassed with a capacitor if the regulator is connected to the power supply filter with long wire lengths, or if the output load capacitance is large. An input bypass capacitor should be selected to provide good high-frequency characteristics to insure stable operation under all load conditions. A 0.33 μF or larger tantalum, mylar, or other capacitor having low internal impedance at high frequencies should be chosen. The capacitor chosen should have an equivalent series resistance of less than 0.7 Ω . The bypass capacitor should be mounted with the shortest possible leads directly across the regulators input terminals. Normally good construction techniques should be used to minimize ground loops and lead resistance drops since the regulator has no external sense lead. Bypassing the output is also recommended.

Figure 7. Current Regulator

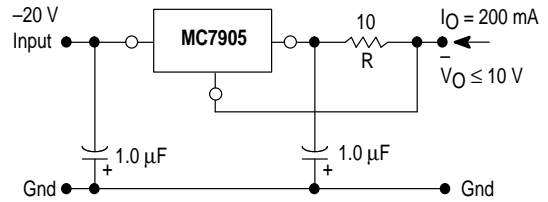

The MC7905, -5.0 V regulator can be used as a constant current source when connected as above. The output current is the sum of resistor R current and quiescent bias current as follows.

$$I_O = \frac{5.0 \text{ V}}{R} + I_B$$

The quiescent current for this regulator is typically 4.3 mA. The 5.0 V regulator was chosen to minimize dissipation and to allow the output voltage to operate to within 6.0 V below the input voltage.

Figure 8. Current Boost Regulator
(-5.0 V @ 4.0 A, with 5.0 A Current Limiting)

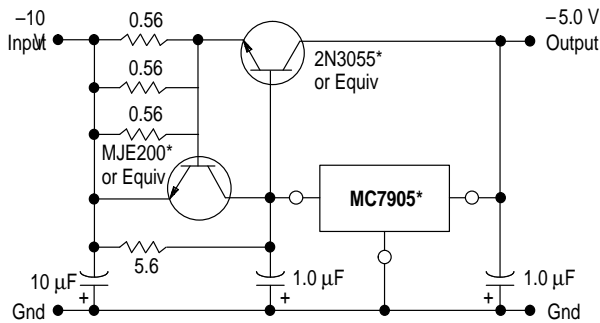

*Mounted on heatsink.

When a boost transistor is used, short circuit currents are equal to the sum of the series pass and regulator limits, which are measured at 3.2 A and 1.8 A respectively in this case. Series pass limiting is approximately equal to 0.6 V/R_{SC}. Operation beyond this point to the peak current capability of the MC7905C is possible if the regulator is mounted on a heatsink; otherwise thermal shutdown will occur when the additional load current is picked up by the regulator.

Figure 9. Operational Amplifier Supply
(±15 @ 1.0 A)

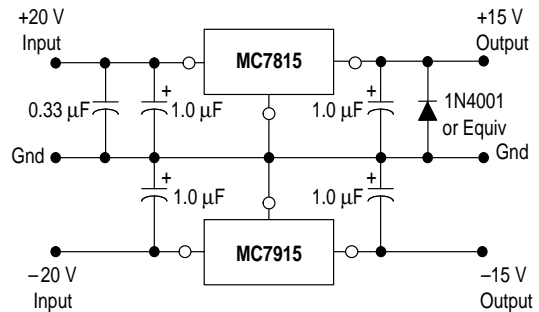

The MC7815 and MC7915 positive and negative regulators may be connected as shown to obtain a dual power supply for operational amplifiers. A clamp diode should be used at the output of the MC7815 to prevent potential latch-up problems whenever the output of the positive regulator (MC7815) is drawn below ground with an output current greater than 200 mA.

MC7900

Figure 10. D²PAK Thermal Resistance and Maximum Power Dissipation versus P.C.B. Copper Length

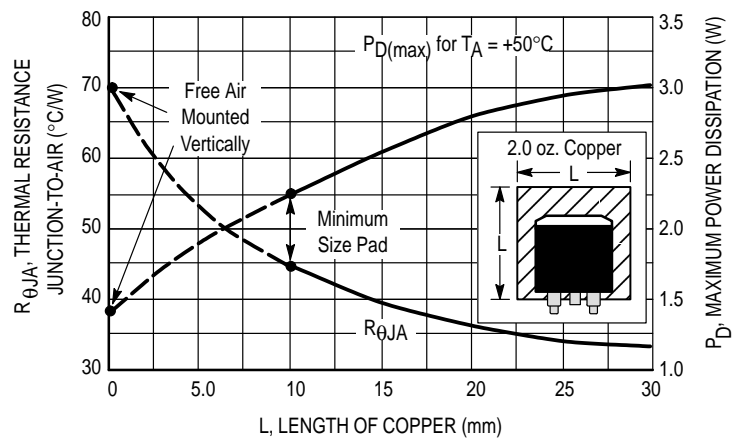

DEFINITIONS

Line Regulation – The change in output voltage for a change in the input voltage. The measurement is made under conditions of low dissipation or by using pulse techniques such that the average chip temperature is not significantly affected.

Load Regulation – The change in output voltage for a change in load current at constant chip temperature.

Maximum Power Dissipation – The maximum total device dissipation for which the regulator will operate within specifications.

Input Bias Current – That part of the input current that is not delivered to the load.

Output Noise Voltage – The rms AC voltage at the output, with constant load and no input ripple, measured over a specified frequency range.

Long Term Stability – Output voltage stability under accelerated life test conditions with the maximum rated voltage listed in the devices' electrical characteristics and maximum power dissipation.

MC7900

OUTLINE DIMENSIONS

T SUFFIX PLASTIC PACKAGE CASE 221A-06 ISSUE Y

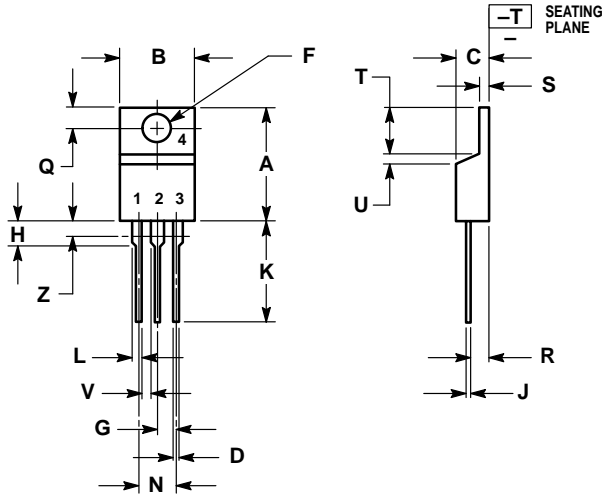

NOTES:

1. DIMENSIONING AND TOLERANCING PER ANSI Y14.5M, 1982.
2. CONTROLLING DIMENSION: INCH.
3. DIM Z DEFINES A ZONE WHERE ALL BODY AND LEAD IRREGULARITIES ARE ALLOWED.

DIM	INCHES		MILLIMETERS	
	MIN	MAX	MIN	MAX
A	0.570	0.620	14.48	15.75
B	0.380	0.405	9.66	10.28
C	0.160	0.190	4.07	4.82
D	0.025	0.035	0.64	0.88
F	0.142	0.147	3.61	3.73
G	0.095	0.105	2.42	2.66
H	0.110	0.155	2.80	3.93
J	0.018	0.025	0.46	0.64
K	0.500	0.562	12.70	14.27
L	0.045	0.060	1.15	1.52
N	0.190	0.210	4.83	5.33
Q	0.100	0.120	2.54	3.04
R	0.080	0.110	2.04	2.79
S	0.045	0.055	1.15	1.39
T	0.235	0.255	5.97	6.47
U	0.000	0.050	0.00	1.27
V	0.045	-	1.15	-
Z	-	0.080	-	2.04

D2T SUFFIX PLASTIC PACKAGE CASE 936-03 (D²PAK) ISSUE B

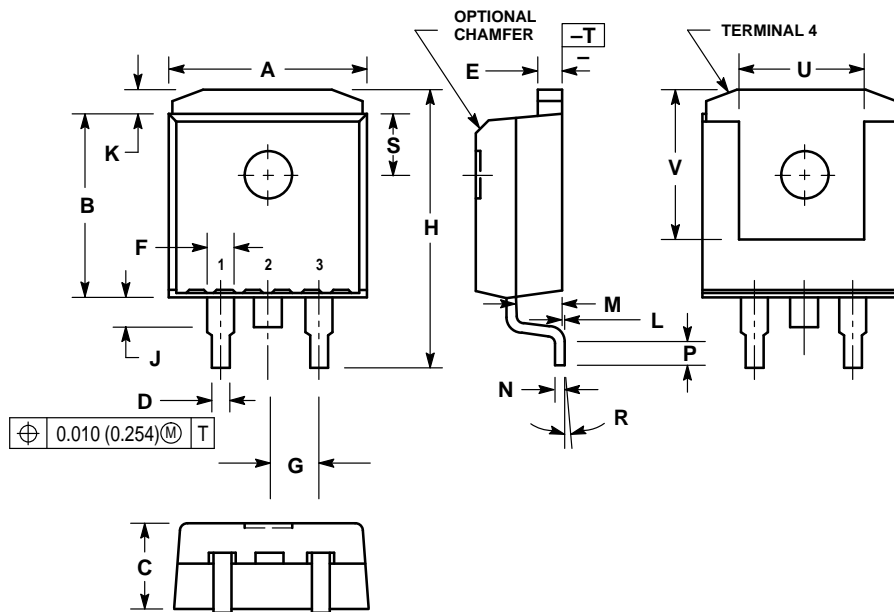

NOTES:

1. DIMENSIONING AND TOLERANCING PER ANSI Y14.5M, 1982.
2. CONTROLLING DIMENSION: INCH.
3. TAB CONTOUR OPTIONAL WITHIN DIMENSIONS A AND K.
4. DIMENSIONS U AND V ESTABLISH A MINIMUM MOUNTING SURFACE FOR TERMINAL 4.
5. DIMENSIONS A AND B DO NOT INCLUDE MOLD FLASH OR GATE PROTRUSIONS. MOLD FLASH AND GATE PROTRUSIONS NOT TO EXCEED 0.025 (0.635) MAXIMUM.

DIM	INCHES		MILLIMETERS	
	MIN	MAX	MIN	MAX
A	0.386	0.403	9.804	10.236
B	0.356	0.368	9.042	9.347
C	0.170	0.180	4.318	4.572
D	0.026	0.036	0.660	0.914
E	0.045	0.055	1.143	1.397
F	0.051	REF	1.295	REF
G	0.100	BSC	2.540	BSC
H	0.539	0.579	13.691	14.707
J	0.125	MAX	3.175	MAX
K	0.050	REF	1.270	REF
L	0.000	0.010	0.000	0.254
M	0.088	0.102	2.235	2.591
N	0.018	0.026	0.457	0.660
P	0.058	0.078	1.473	1.981
R	5°	REF	5°	REF
S	0.116	REF	2.946	REF
U	0.200	MIN	5.080	MIN
V	0.250	MIN	6.350	MIN

MC7900

Motorola reserves the right to make changes without further notice to any products herein. Motorola makes no warranty, representation or guarantee regarding the suitability of its products for any particular purpose, nor does Motorola assume any liability arising out of the application or use of any product or circuit, and specifically disclaims any and all liability, including without limitation consequential or incidental damages. "Typical" parameters which may be provided in Motorola data sheets and/or specifications can and do vary in different applications and actual performance may vary over time. All operating parameters, including "Typicals" must be validated for each customer application by customer's technical experts. Motorola does not convey any license under its patent rights nor the rights of others. Motorola products are not designed, intended, or authorized for use as components in systems intended for surgical implant into the body, or other applications intended to support or sustain life, or for any other application in which the failure of the Motorola product could create a situation where personal injury or death may occur. Should Buyer purchase or use Motorola products for any such unintended or unauthorized application, Buyer shall indemnify and hold Motorola and its officers, employees, subsidiaries, affiliates, and distributors harmless against all claims, costs, damages, and expenses, and reasonable attorney fees arising out of, directly or indirectly, any claim of personal injury or death associated with such unintended or unauthorized use, even if such claim alleges that Motorola was negligent regarding the design or manufacture of the part. Motorola and  are registered trademarks of Motorola, Inc. Motorola, Inc. is an Equal Opportunity/Affirmative Action Employer.

How to reach us:

USA/EUROPE/Locations Not Listed: Motorola Literature Distribution;
P.O. Box 20912; Phoenix, Arizona 85036. 1-800-441-2447 or 602-303-5454

MFAX: RMFAX0@email.sps.mot.com – TOUCHTONE 602-244-6609
INTERNET: <http://Design-NET.com>

JAPAN: Nippon Motorola Ltd.; Tatsumi-SPD-JLDC, 6F Seibu-Butsuryu-Center,
3-14-2 Tatsumi Koto-Ku, Tokyo 135, Japan. 03-81-3521-8315

ASIA/PACIFIC: Motorola Semiconductors H.K. Ltd.; 8B Tai Ping Industrial Park,
51 Ting Kok Road, Tai Po, N.T., Hong Kong. 852-26629298



MOTOROLA