

- **Member of the Texas Instruments Widebus™ Family**
- **Designed to Be Used in Voltage-Limiting Applications**
- **6.5-Ω On-State Connection Between Ports A and B**
- **Flow-Through Pinout for Ease of Printed Circuit Board Trace Routing**
- **Direct Interface With GTL+ Levels**
- **ESD Protection Exceeds JESD 22**
 - 2000-V Human-Body Model (A114-A)
 - 200-V Machine Model (A115-A)
 - 1000-V Charged-Device Model (C101)

description/ordering information

The SN74TVC16222A provides 23 parallel NMOS pass transistors with a common gate. The low on-state resistance of the switch allows connections to be made with minimal propagation delay.

The device can be used as a 22-bit switch, with the gates cascaded together to a reference transistor. The low-voltage side of each pass transistor is limited to a voltage set by the reference transistor. This is done to protect components with inputs that are sensitive to high-state voltage-level overshoots. (See *Application Information* in this data sheet.)

All of the transistors in the TVC array have the same electrical characteristics; therefore, any one of them can be used as the reference transistor. Because, within the device, the characteristics from transistor to transistor are equal, the maximum output high-state voltage (V_{OH}) is approximately the reference voltage (V_{REF}), with minimal deviation from one output to another. This is a benefit of the TVC solution over discrete devices. Because the fabrication of the transistors is symmetrical, either port connection of each bit can be used as the low-voltage side, and the I/O signals are bidirectional through each FET.

DGG, DGV, OR DL PACKAGE (TOP VIEW)

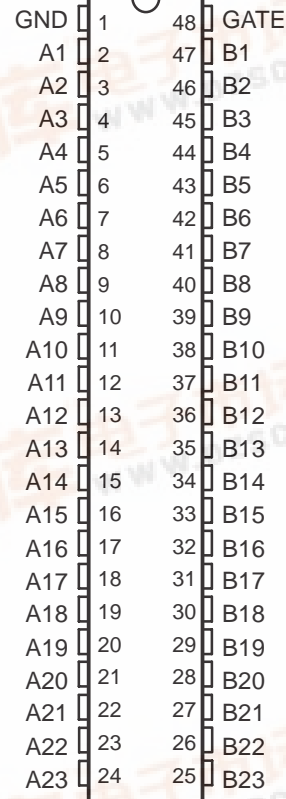

ORDERING INFORMATION

TA	PACKAGE†		ORDERABLE PART NUMBER	TOP-SIDE MARKING
-40°C to 85°C	SSOP – DL	Tube	SN74TVC16222DL	TVC16222A
		Tape and reel	SN74TVC16222DLR	
	TSSOP – DGG	Tape and reel	SN74TVC16222DGGR	TVC16222A
		TVSOP – DGV	Tape and reel	SN74TVC16222DGVR

† Package drawings, standard packing quantities, thermal data, symbolization, and PCB design guidelines are available at www.ti.com/sc/package.

Please be aware that an important notice concerning availability, standard warranty, and use in critical applications of Texas Instruments semiconductor products and disclaimers thereto appears at the end of this data sheet.

Widebus and TI are trademarks of Texas Instruments.

PRODUCTION DATA information is current as of publication date. Products conform to specifications per the terms of Texas Instruments standard warranty. Production processing does not necessarily include testing of all parameters.



SN74TVC16222A

22-BIT VOLTAGE CLAMP

SCDS087G – APRIL 1999 – REVISED APRIL 2005

simplified schematic

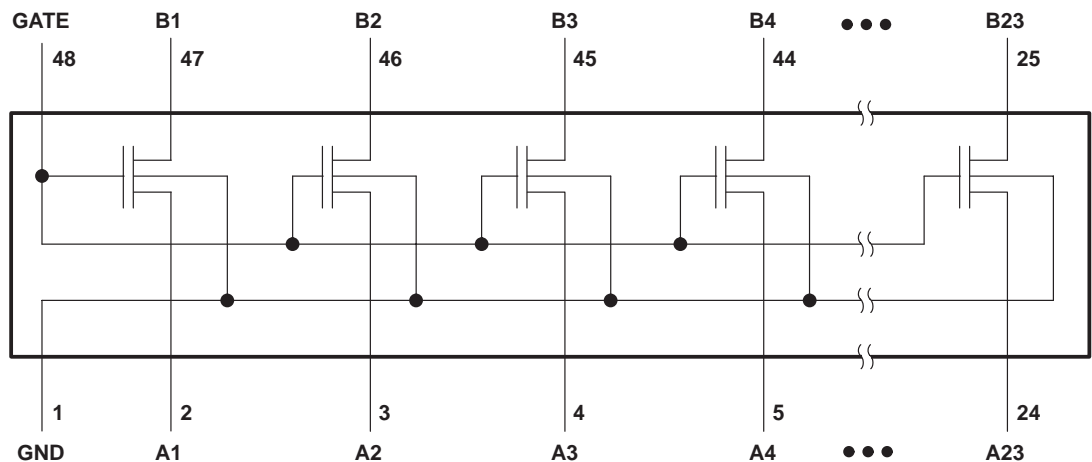

absolute maximum ratings over operating free-air temperature range (unless otherwise noted)†

Input voltage range, V_I (see Note 1)	-0.5 V to 7 V
Input/output voltage range, $V_{I/O}$ (see Note 1)	-0.5 V to 7 V
Continuous channel current	128 mA
Input clamp current, I_{IK} ($V_I < 0$)	-50 mA
Package thermal impedance, θ_{JA} (see Note 2):		
DGG package	70°C/W
DGV package	58°C/W
DL package	63°C/W
Storage temperature range, T_{stg}	-65°C to 150°C

† Stresses beyond those listed under “absolute maximum ratings” may cause permanent damage to the device. These are stress ratings only, and functional operation of the device at these or any other conditions beyond those indicated under “recommended operating conditions” is not implied. Exposure to absolute-maximum-rated conditions for extended periods may affect device reliability.

- NOTES: 1. The input and input/output negative-voltage ratings may be exceeded if the input and input/output clamp-current ratings are observed.
 2. The package thermal impedance is calculated in accordance with JESD 51-7.

recommended operating conditions

		MIN	TYP	MAX	UNIT
$V_{I/O}$	Input/output voltage	0		5.5	V
V_{GATE}	GATE voltage	0		5.5	V
I_{PASS}	Pass-transistor current		20	64	mA
T_A	Operating free-air temperature	-40		85	°C

application operating conditions (see Figure 3)

		MIN	TYP	MAX	UNIT
V_{BIAS}	BIAS voltage	$V_{REF} + 0.6$	2.1	5	V
V_{GATE}	GATE voltage	$V_{REF} + 0.6$	2.1	5	V
V_{REF}	Reference voltage	0	1.5	4.4	V
V_{DPU}	Drain pullup voltage	2.36	2.5	2.64	V
I_{PASS}	Pass-transistor current		14	20	mA
I_{REF}	Reference-transistor current		5		µA
T_A	Operating free-air temperature	-40		85	°C

SN74TVC16222A 22-BIT VOLTAGE CLAMP

SCDS087G – APRIL 1999 – REVISED APRIL 2005

electrical characteristics over recommended operating free-air temperature range (unless otherwise noted)

PARAMETER	TEST CONDITIONS			MIN	TYP†	MAX	UNIT
V_{IK}	$V_{BIAS} = 0,$	$I_I = -18 \text{ mA}$				-1.2	V
V_{OL}	$I_{REF} = 5 \mu\text{A},$ $V_{DPU} = 2.625 \text{ V},$	$V_{REF} = 1.365 \text{ V},$ $R_{DPU} = 150 \Omega$	$V_S = 0.175 \text{ V},$ See Figure 2			350	mV
$C_{i(GATE)}$	$V_I = 3 \text{ V or } 0$				73		pF
$C_{io(off)}$	$V_O = 3 \text{ V or } 0$				4	12	pF
$C_{io(on)}$	$V_O = 3 \text{ V or } 0$				12	25	pF
$r_{on}‡$	$I_{REF} = 5 \mu\text{A},$ $V_{DPU} = 2.625 \text{ V},$	$V_{REF} = 1.365 \text{ V},$ $R_{DPU} = 150 \Omega$	$V_S = 0.175 \text{ V},$ See Figure 2			12.5	Ω

† All typical values are at $T_A = 25^\circ\text{C}$.

‡ Measured by the voltage drop between the A and B terminals at the indicated current through the switch. On-state resistance is determined by the lower voltage of the two (A or B) terminals.

electrical characteristics from -40°C to 75°C

PARAMETER	TEST CONDITIONS			MIN	MAX	UNIT
$r_{on}‡$	$I_{REF} = 5 \mu\text{A},$ $V_{DPU} = 2.625 \text{ V},$	$V_{REF} = 1.552 \text{ V},$ $R_{DPU} = 150 \Omega$	$V_S = 0.175 \text{ V},$ See Figure 2		10	Ω

‡ Measured by the voltage drop between the A and B terminals at the indicated current through the switch. On-state resistance is determined by the lower voltage of the two (A or B) terminals.

switching characteristics over recommended operating free-air temperature range, $V_{DPU} = 2.36 \text{ V to } 2.64 \text{ V}$ (unless otherwise noted) (see Figure 1)

PARAMETER	FROM (INPUT)	TO (OUTPUT)	MIN	MAX	UNIT
t_{PLH}	A or B	B or A	0	4	ns
t_{PHL}			0	4	

SN74TVC16222A 22-BIT VOLTAGE CLAMP

SCDS087G – APRIL 1999 – REVISED APRIL 2005

PARAMETER MEASUREMENT INFORMATION

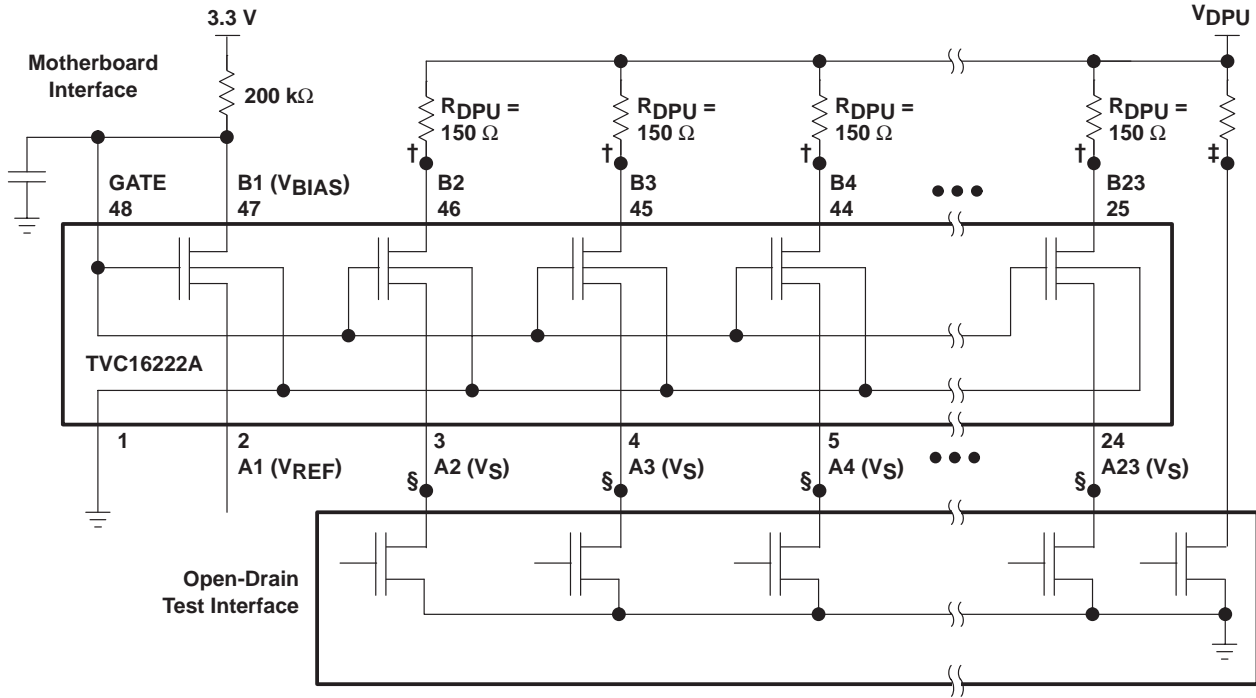

TESTER CALIBRATION SETUP (see Note C)

DEFINITION	SYMBOL
Output tested	†
Output reference	‡
Input tested	§

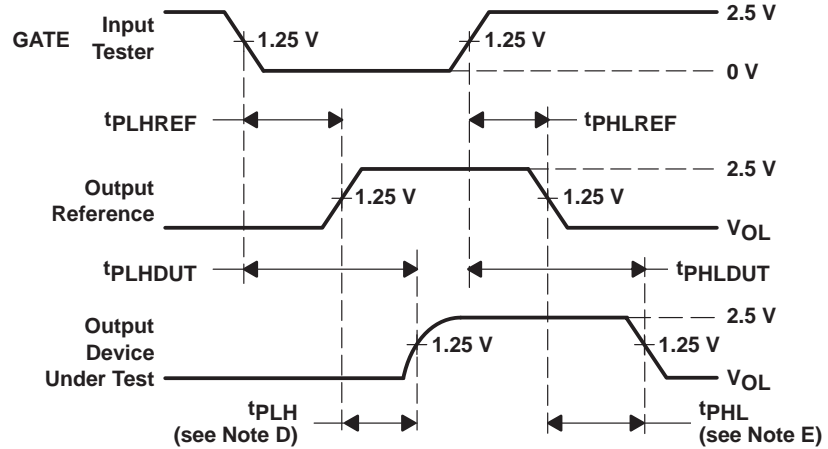

VOLTAGE WAVEFORMS
PROPAGATION DELAY TIMES

- NOTES:
- A. All input pulses are supplied by generators having the following characteristics: PRR ≤ 10 MHz, Z_O = 50 Ω, t_r ≤ 2 ns, t_f ≤ 2 ns.
 - B. The outputs are measured one at a time, with one transition per measurement.
 - C. Test procedure: t_{PLHREF} and t_{PHLREF} are obtained by measuring the propagation delay of a reference measuring point. t_{PLHDUT} and t_{PHLDUT} are obtained by measuring the propagation delay of the device under test.
 - D. t_{PLH} = t_{PLHDUT} - t_{PLHREF}
 - E. t_{PHL} = t_{PHLDUT} - t_{PHLREF}

Figure 1. Tester Calibration Setup and Voltage Waveforms

APPLICATION INFORMATION

TVC background information

In personal computer (PC) architecture, there are industry-accepted bus standards. These standards define, among other things, the I/O voltage levels at which the bus communicates. Examples include the GTL+ host bus, the AGP graphics port, and the PCI local bus. In new designs, the system components must communicate with existing bus infrastructure. Providing an evolutionary upgrade path is important in the design of PC architecture, but the existing bus standards must be preserved.

To achieve the ever-present need for smaller, faster, lighter devices that draw less power, yet have faster performance, most new high-performance digital integrated circuits are designed and produced with advanced submicron semiconductor process technologies. These devices have thin gate-oxide or short channel lengths and very low absolute-maximum voltages that can be tolerated at the inputs/outputs (I/Os) without causing damage. In many cases, the I/Os of these devices are not tolerant of the high-state voltage levels on the preexisting buses with which they must communicate. Therefore, it became necessary to protect the I/Os of devices by limiting the I/O voltages.

The Texas Instruments (TI™) translation voltage-clamp (TVC) family is designed specifically for protecting sensitive I/Os (see Figure 2). The information in this data sheet describes the I/O-protection application of the TVC family and should enable the design engineer to successfully implement an I/O-protection circuit utilizing the TI TVC solution.

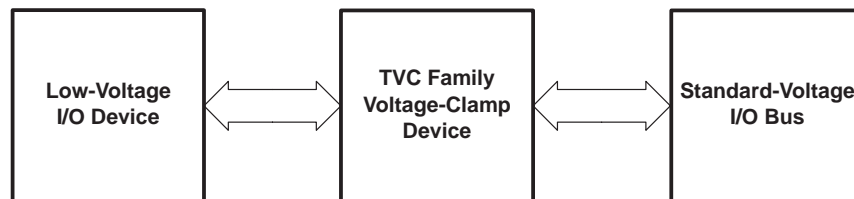

Figure 2. Thin Gate-Oxide Protection Application

SN74TVC16222A 22-BIT VOLTAGE CLAMP

SCDS087G – APRIL 1999 – REVISED APRIL 2005

APPLICATION INFORMATION

TVC voltage-limiting application

For the voltage-limiting configuration, the common GATE input must be connected to one side (A or B) of any one of the transistors (see Figure 3). This connection determines the V_{BIAS} input of the reference transistor. The V_{BIAS} input is connected through a pullup resistor (typically $200\text{ k}\Omega$) to the V_{DD} supply. A filter capacitor on V_{BIAS} is recommended. The opposite side of the reference transistor is used as the reference voltage (V_{REF}) connection. The V_{REF} input must be less than $V_{DDREF} - 1\text{ V}$ to bias the reference transistor into conduction. The reference transistor regulates the gate voltage (V_{GATE}) of all the pass transistors. V_{GATE} is determined by the characteristic gate-to-source voltage difference (V_{GS}) because $V_{GATE} = V_{REF} + V_{GS}$. The low-voltage side of the pass transistors has a high-level voltage limited to a maximum of $V_{GATE} - V_{GS}$, or V_{REF} .

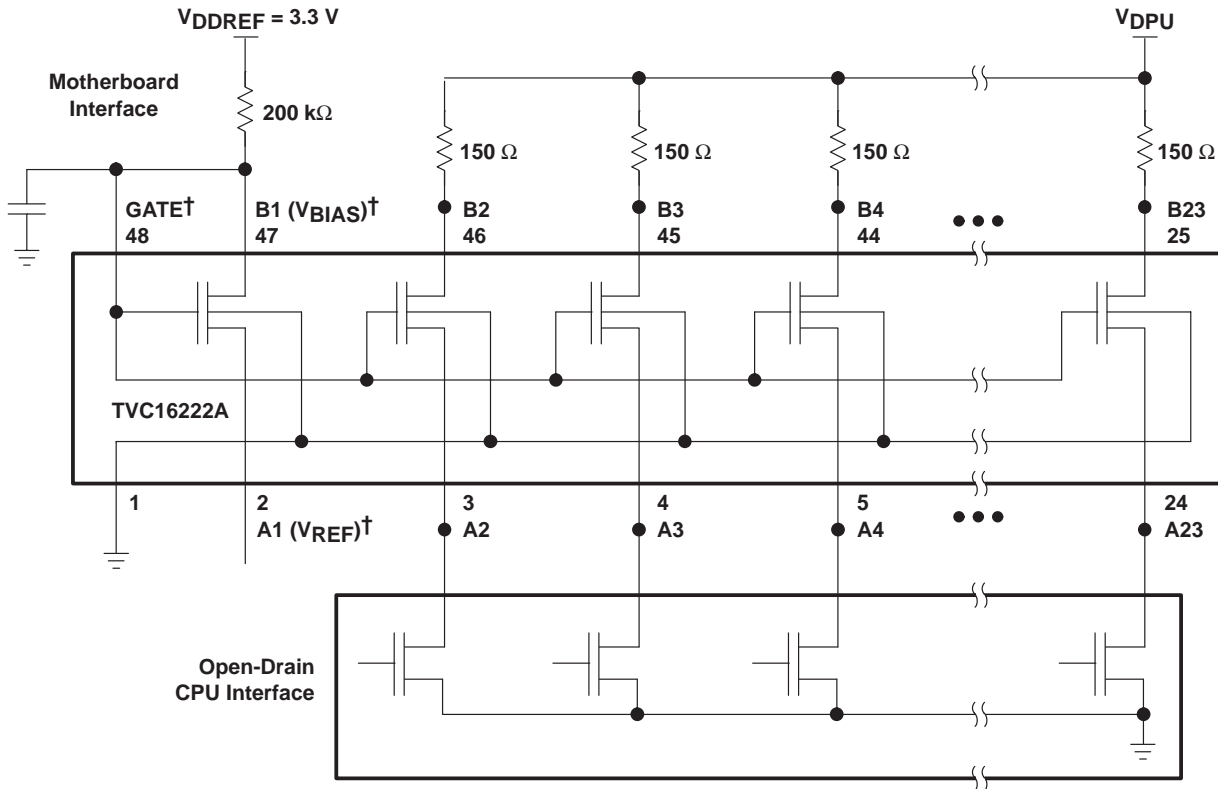

† V_{REF} and V_{BIAS} can be applied to any one of the pass transistors. GATE must be connected externally to V_{BIAS} .

Figure 3. Typical Application Circuit

APPLICATION INFORMATION

electrical characteristics

The electrical characteristics of the NMOS transistors used in the TVC devices are illustrated by TI SPICE simulations. Figure 4 shows the test configuration for the TI SPICE simulations. The results, shown in Figures 5 and 6, show the current through a pass transistor versus the voltage at the source for different reference voltages. The plots of the dc characteristics clearly reveal that the device clamps at the desired reference voltage for the varying device environments.

Figure 5 shows the V-I characteristics with low reference voltages and a reference-transistor drain-supply voltage of 3.3 V. To further investigate the spread of the V-I characteristic curves, V_{REF} was held at 2.5 V and I_{REF} was increased by raising V_{DDREF} (see Figure 6). The result was a tighter grouping of the V-I curves.

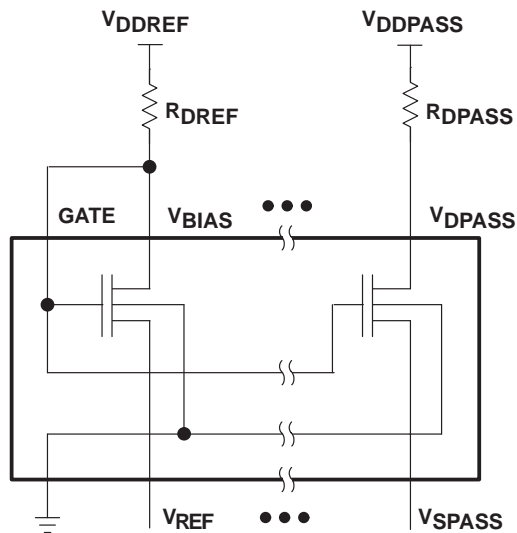

Figure 4. TI SPICE-Simulation Schematic and Voltage-Node Names

SN74TVC16222A 22-BIT VOLTAGE CLAMP

SCDS087G – APRIL 1999 – REVISED APRIL 2005

APPLICATION INFORMATION

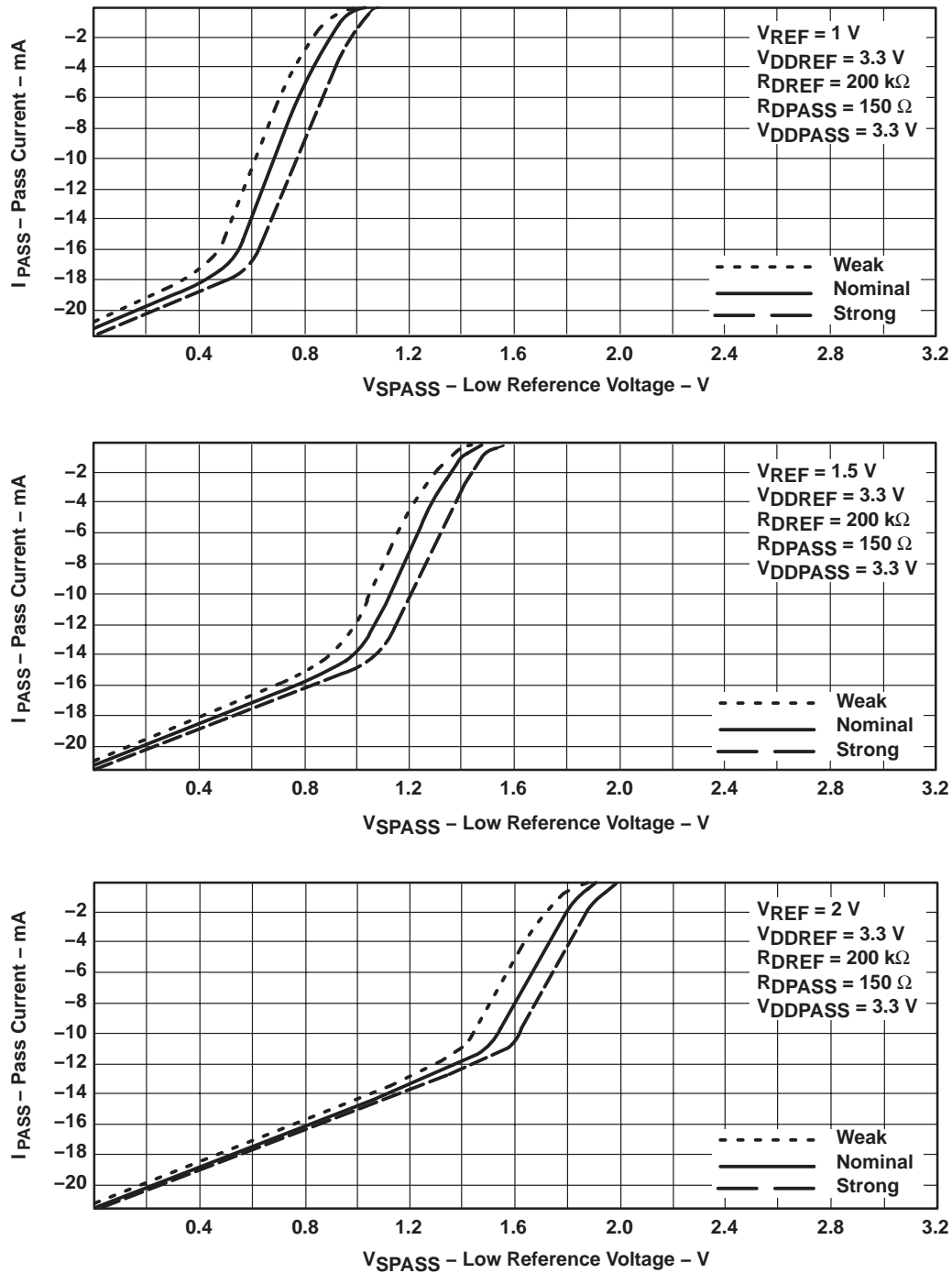

Figure 5. V-I Electrical Characteristics at Low V_{REF} Voltages

APPLICATION INFORMATION

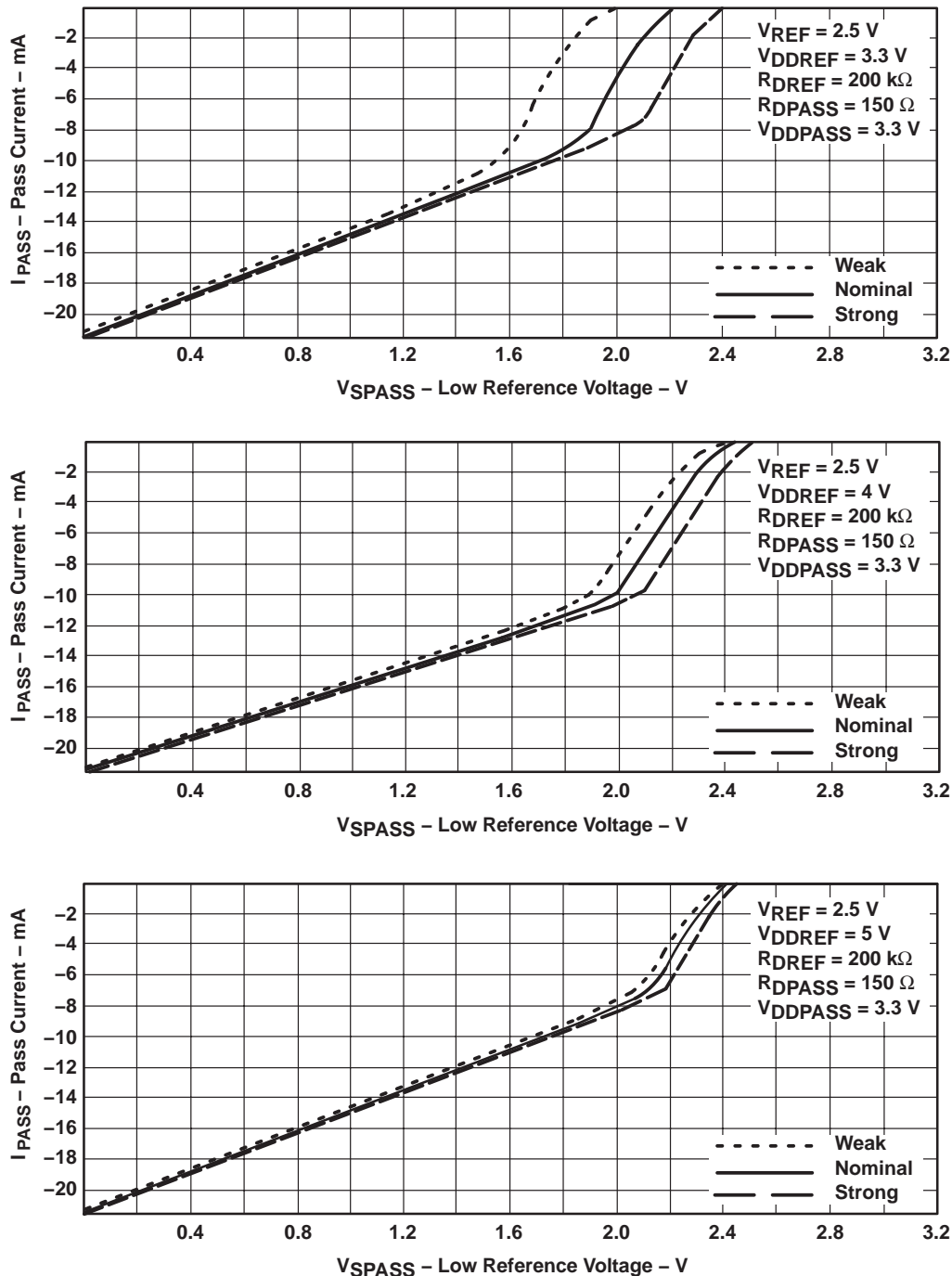

Figure 6. V-I Electrical Characteristics at $V_{REF} = 2.5\text{ V}$

SN74TVC16222A

22-BIT VOLTAGE CLAMP

SCDS087G – APRIL 1999 – REVISED APRIL 2005

APPLICATION INFORMATION

features and benefits

The TVC family has several features that benefit a system designer when implementing a sensitive-I/O-protection solution. Table 1 lists these features and their associated benefits.

Table 1. Features and Benefits

FEATURES	BENEFITS
Any FET can be used as the reference transistor.	Ease of layout
All FETs on one die, tight process control	Very low spread of V_O relative to V_{REF}
No active control logic (passive device)	No logic power supply (V_{CC}) required
Flow-through pinout	Ease of trace routing
Devices offered in different bit widths and packages	Optimizes design and cost effectiveness
Designer flexibility with V_{REF} input	Allows migration to lower-voltage I/Os without board redesign

conclusion

The TI TVC family provides the designer with a solution for protection of circuits with I/Os that are sensitive to high-state voltage-level overshoots. The flexibility of TVC enables a low-voltage migration path for advanced designs to align with industry standards.

frequently asked questions (FAQs)

- Q: Can any of the transistors in the array be used as the reference transistor?

A: Yes, any transistor can be used as long as its V_{BIAS} pin is connected to the GATE pin.
- Q: In the *recommended operating conditions* table of the data sheet, the typical V_{BIAS} is 3.3 V. Should V_{BIAS} be equal to or greater than V_{REF} on the reference transistor?

A: V_{BIAS} is a variable that is determined by V_{REF} . V_{BIAS} is connected to V_{DD} through a resistor to allow the bias voltage to be controlled by V_{REF} . V_{DD} can be as high as 5.5 V. V_{REF} needs to be at least 1 V less than V_{DDREF} on the reference transistor.
- Q: Do both A and B ports have 5-V I/O tolerance or is 5-V I/O tolerance provided only on the low-voltage side?

A: Both ports are 5-V tolerant.

PACKAGING INFORMATION

Orderable Device	Status ⁽¹⁾	Package Type	Package Drawing	Pins	Package Qty	Eco Plan ⁽²⁾	Lead/Ball Finish	MSL Peak Temp ⁽³⁾
74TVC16222ADGGRE4	ACTIVE	TSSOP	DGG	48	2000	Green (RoHS & no Sb/Br)	CU NIPDAU	Level-1-260C-UNLIM
74TVC16222ADGVRE4	ACTIVE	TVSOP	DGV	48	2000	Green (RoHS & no Sb/Br)	CU NIPDAU	Level-1-260C-UNLIM
SN74TVC16222ADGGR	ACTIVE	TSSOP	DGG	48	2000	Green (RoHS & no Sb/Br)	CU NIPDAU	Level-1-260C-UNLIM
SN74TVC16222ADGVR	ACTIVE	TVSOP	DGV	48	2000	Green (RoHS & no Sb/Br)	CU NIPDAU	Level-1-260C-UNLIM
SN74TVC16222ADL	ACTIVE	SSOP	DL	48	25	Green (RoHS & no Sb/Br)	CU NIPDAU	Level-1-260C-UNLIM
SN74TVC16222ADLR	ACTIVE	SSOP	DL	48	1000	Green (RoHS & no Sb/Br)	CU NIPDAU	Level-1-260C-UNLIM

⁽¹⁾ The marketing status values are defined as follows:

ACTIVE: Product device recommended for new designs.

LIFEBUY: TI has announced that the device will be discontinued, and a lifetime-buy period is in effect.

NRND: Not recommended for new designs. Device is in production to support existing customers, but TI does not recommend using this part in a new design.

PREVIEW: Device has been announced but is not in production. Samples may or may not be available.

OBSELETE: TI has discontinued the production of the device.

⁽²⁾ Eco Plan - The planned eco-friendly classification: Pb-Free (RoHS) or Green (RoHS & no Sb/Br) - please check <http://www.ti.com/productcontent> for the latest availability information and additional product content details.

TBD: The Pb-Free/Green conversion plan has not been defined.

Pb-Free (RoHS): TI's terms "Lead-Free" or "Pb-Free" mean semiconductor products that are compatible with the current RoHS requirements for all 6 substances, including the requirement that lead not exceed 0.1% by weight in homogeneous materials. Where designed to be soldered at high temperatures, TI Pb-Free products are suitable for use in specified lead-free processes.

Green (RoHS & no Sb/Br): TI defines "Green" to mean Pb-Free (RoHS compatible), and free of Bromine (Br) and Antimony (Sb) based flame retardants (Br or Sb do not exceed 0.1% by weight in homogeneous material)

⁽³⁾ MSL, Peak Temp. -- The Moisture Sensitivity Level rating according to the JEDEC industry standard classifications, and peak solder temperature.

Important Information and Disclaimer:The information provided on this page represents TI's knowledge and belief as of the date that it is provided. TI bases its knowledge and belief on information provided by third parties, and makes no representation or warranty as to the accuracy of such information. Efforts are underway to better integrate information from third parties. TI has taken and continues to take reasonable steps to provide representative and accurate information but may not have conducted destructive testing or chemical analysis on incoming materials and chemicals. TI and TI suppliers consider certain information to be proprietary, and thus CAS numbers and other limited information may not be available for release.

In no event shall TI's liability arising out of such information exceed the total purchase price of the TI part(s) at issue in this document sold by TI to Customer on an annual basis.

MECHANICAL DATA

MPDS006C – FEBRUARY 1996 – REVISED AUGUST 2000

DGV (R-PDSO-G**)

PLASTIC SMALL-OUTLINE

24 PINS SHOWN

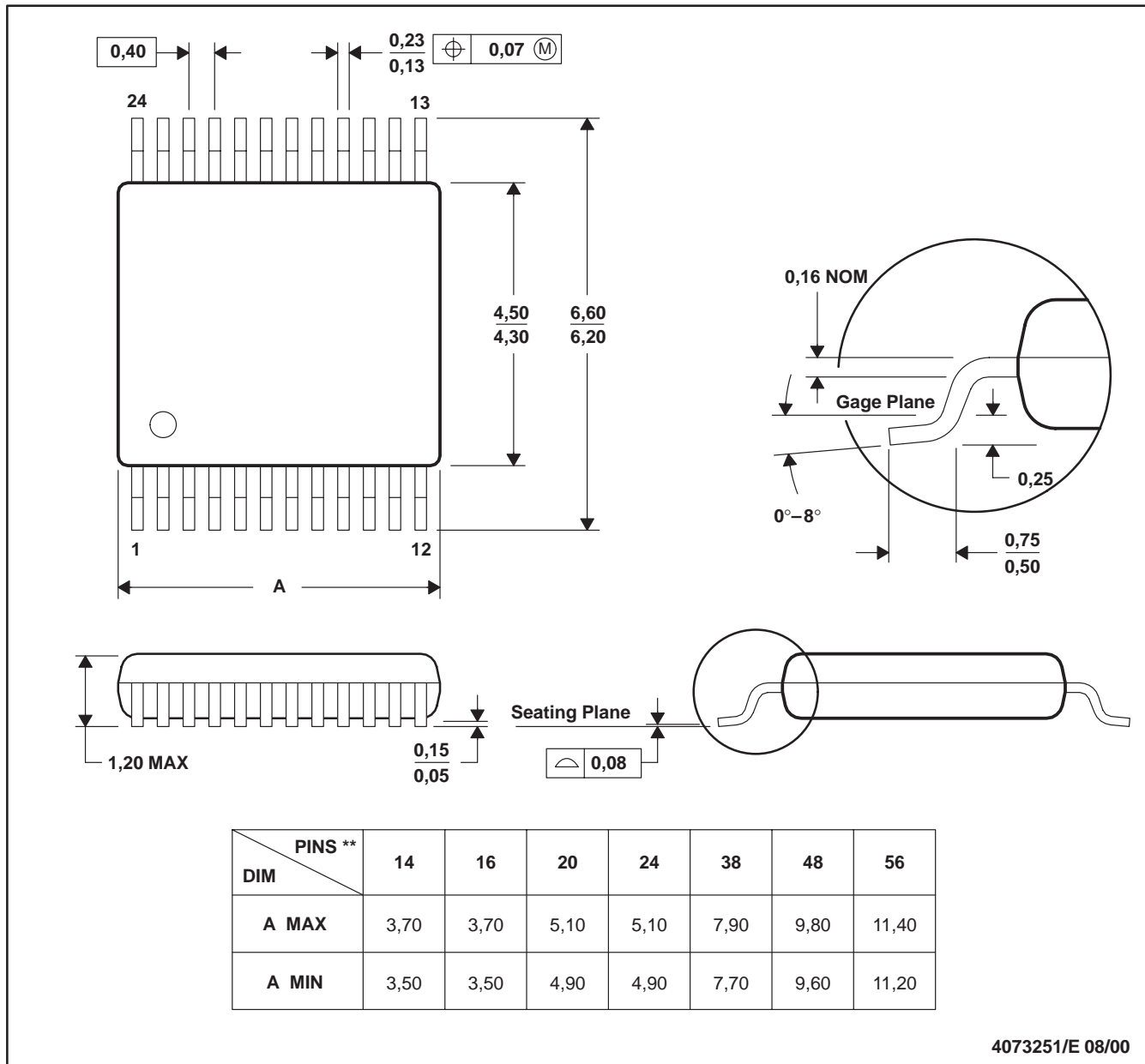

- NOTES: A. All linear dimensions are in millimeters.
 B. This drawing is subject to change without notice.
 C. Body dimensions do not include mold flash or protrusion, not to exceed 0,15 per side.
 D. Falls within JEDEC: 24/48 Pins – MO-153
 14/16/20/56 Pins – MO-194

MECHANICAL DATA

MSS0001C – JANUARY 1995 – REVISED DECEMBER 2001

DL (R-PDSO-G)**

PLASTIC SMALL-OUTLINE PACKAGE

48 PINS SHOWN

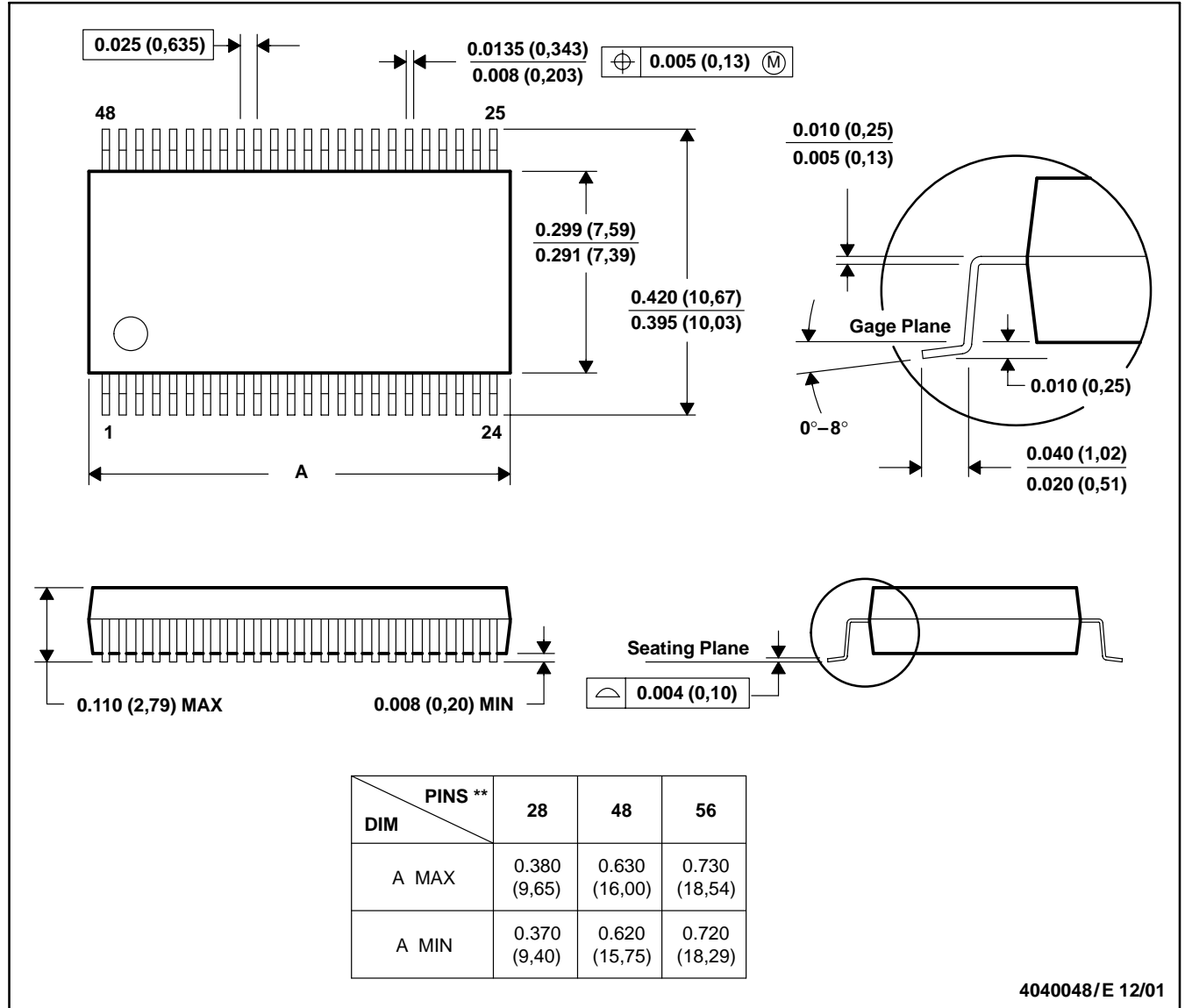

- NOTES: A. All linear dimensions are in inches (millimeters).
 B. This drawing is subject to change without notice.
 C. Body dimensions do not include mold flash or protrusion not to exceed 0.006 (0,15).
 D. Falls within JEDEC MO-118

MECHANICAL DATA

MTSS003D – JANUARY 1995 – REVISED JANUARY 1998

DGG (R-PDSO-G**)

PLASTIC SMALL-OUTLINE PACKAGE

48 PINS SHOWN

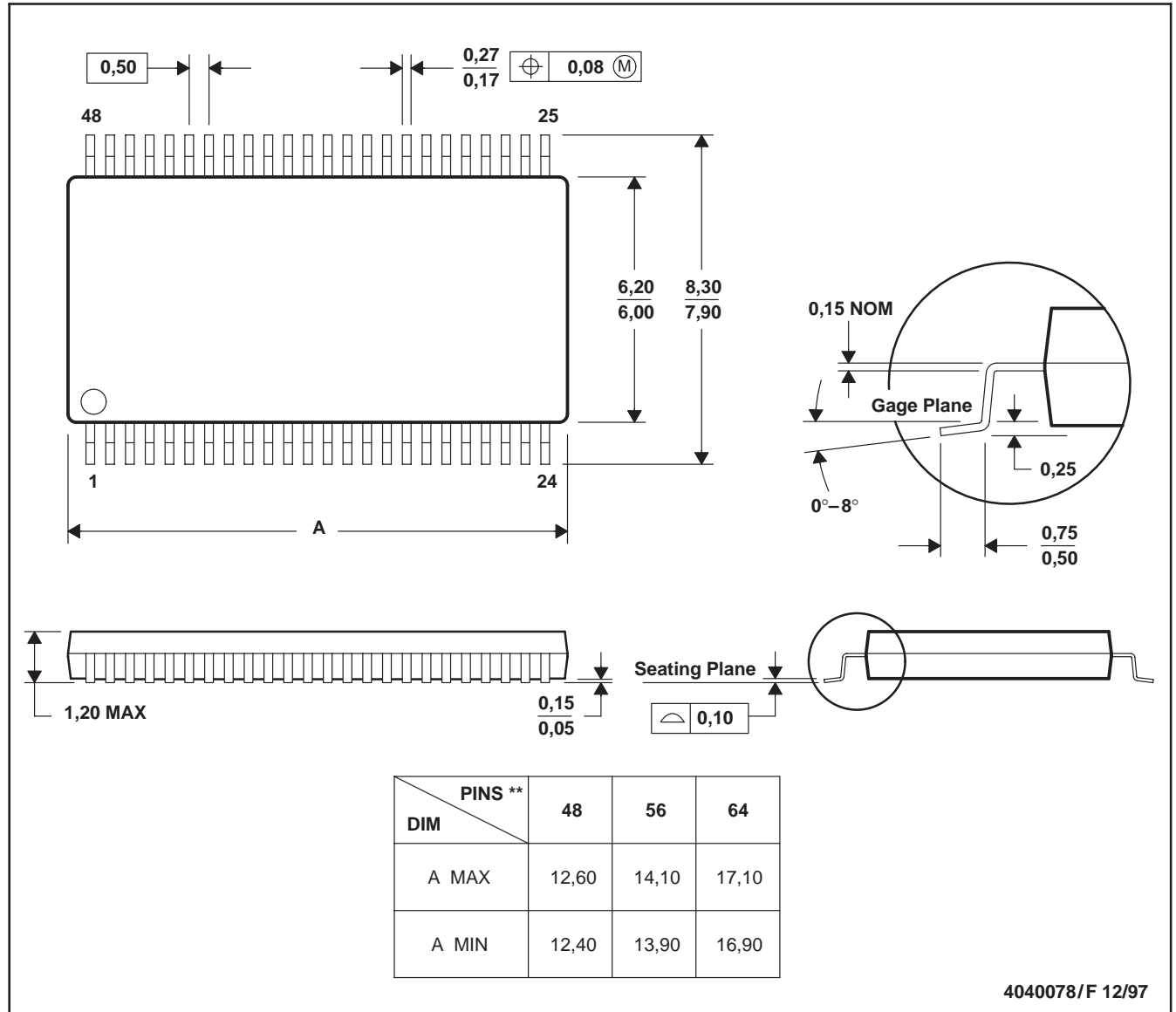

- NOTES: A. All linear dimensions are in millimeters.
 B. This drawing is subject to change without notice.
 C. Body dimensions do not include mold protrusion not to exceed 0,15.
 D. Falls within JEDEC MO-153

IMPORTANT NOTICE

Texas Instruments Incorporated and its subsidiaries (TI) reserve the right to make corrections, modifications, enhancements, improvements, and other changes to its products and services at any time and to discontinue any product or service without notice. Customers should obtain the latest relevant information before placing orders and should verify that such information is current and complete. All products are sold subject to TI's terms and conditions of sale supplied at the time of order acknowledgment.

TI warrants performance of its hardware products to the specifications applicable at the time of sale in accordance with TI's standard warranty. Testing and other quality control techniques are used to the extent TI deems necessary to support this warranty. Except where mandated by government requirements, testing of all parameters of each product is not necessarily performed.

TI assumes no liability for applications assistance or customer product design. Customers are responsible for their products and applications using TI components. To minimize the risks associated with customer products and applications, customers should provide adequate design and operating safeguards.

TI does not warrant or represent that any license, either express or implied, is granted under any TI patent right, copyright, mask work right, or other TI intellectual property right relating to any combination, machine, or process in which TI products or services are used. Information published by TI regarding third-party products or services does not constitute a license from TI to use such products or services or a warranty or endorsement thereof. Use of such information may require a license from a third party under the patents or other intellectual property of the third party, or a license from TI under the patents or other intellectual property of TI.

Reproduction of information in TI data books or data sheets is permissible only if reproduction is without alteration and is accompanied by all associated warranties, conditions, limitations, and notices. Reproduction of this information with alteration is an unfair and deceptive business practice. TI is not responsible or liable for such altered documentation.

Resale of TI products or services with statements different from or beyond the parameters stated by TI for that product or service voids all express and any implied warranties for the associated TI product or service and is an unfair and deceptive business practice. TI is not responsible or liable for any such statements.

Following are URLs where you can obtain information on other Texas Instruments products and application solutions:

Products		Applications	
Amplifiers	amplifier.ti.com	Audio	www.ti.com/audio
Data Converters	dataconverter.ti.com	Automotive	www.ti.com/automotive
DSP	dsp.ti.com	Broadband	www.ti.com/broadband
Interface	interface.ti.com	Digital Control	www.ti.com/digitalcontrol
Logic	logic.ti.com	Military	www.ti.com/military
Power Mgmt	power.ti.com	Optical Networking	www.ti.com/opticalnetwork
Microcontrollers	microcontroller.ti.com	Security	www.ti.com/security
		Telephony	www.ti.com/telephony
		Video & Imaging	www.ti.com/video
		Wireless	www.ti.com/wireless

Mailing Address: Texas Instruments
Post Office Box 655303 Dallas, Texas 75265